



**Tort Law:
A 21st-Century
Approach**

Second Edition

Zahr K. Said



Tort Law: A 21st-Century Approach

Zahr K. Said

Associate Dean for Research and Faculty Development
Charles I. Stone Professor of Law
University of Washington School of Law

Second Edition
CALI eLangdell® Press 2022

About the Author

Professor Zahr K. Said is Charles I. Stone Professor of Law at the University of Washington School of Law. Before law school, Said studied comparative literature and holds a Ph.D. from Harvard University and a B.A. from U.C. Berkeley. She received a J.D. from Columbia Law School, where she was a Kent Scholar, served as Articles Editor for the *Columbia Journal of Law and the Arts*, and won the Young B. Smith Prize for Excellence in Torts. Said has taught as a Visiting Professor at the University of Virginia School of Law and Stanford Law School. Said's scholarship focuses on copyright law, litigation, and law and literature. She has taught Torts for over a decade and Said received the Philip A. Trautman 1L Professor of the Year Award (2016). She has also taught an upper division torts theory class and a business torts seminar, as well as copyright and intellectual property classes that involve fundamental tort principles applied in an upper-division context. Torts is her favorite class to teach, just as it was her favorite 1L class.

Notices

This is the second edition of this casebook. Visit [the eLangdell bookstore](#) for the latest version and for revision history.

This work by Zahr K. Said is licensed and published by CALI eLangdell® Press under a [Creative Commons Attribution-NonCommercial-ShareAlike 4.0 International \(CC BY-NC-SA 4.0\)](#) license.

CALI and CALI eLangdell Press reserve under copyright all rights not expressly granted by this Creative Commons license. CALI and CALI eLangdell Press do not assert copyright in US Government works or other public domain material included herein. Permissions beyond the scope of this license may be available through feedback@cali.org.

In brief, the terms of that license are that you may copy, distribute, and display this work, or make derivative works, so long as you give CALI eLangdell Press and the author credit;

- you do not use this work for commercial purposes; and
- you distribute any works derived from this one under the same licensing terms as this.

Suggested attribution format for original work:

Zahr K. Said, Tort Law: A 21st-Century Approach, Second Edition, Published by CALI eLangdell Press. Available under a Creative Commons (CC BY-NC-SA 4.0) License.

CALI® and eLangdell® are United States federally registered trademarks owned by The Center for Computer-Assisted Legal Instruction.

The cover art design is a copyrighted work of CALI, all rights reserved. The CALI graphical logo is a trademark. Should you create derivative works based on the text of this book or other Creative Commons materials therein, you may use this book's cover art and the aforementioned logos, as long as your use does not imply endorsement by CALI. For all other uses beyond the scope of this license, please request written permission from CALI.

This material does not contain nor is intended to be legal advice. Users seeking legal advice should consult with a licensed attorney in their jurisdiction. The editors have endeavored to provide complete and accurate information in this book. However, CALI does not warrant that the information provided is complete and accurate. CALI disclaims all liability to any person for any loss caused by errors or omissions in this collection of information.

ISBN: 979-8-89904-005-4

About eLangdell Press

[The Center for Computer-Assisted Legal Instruction](#) (CALI®) is: a nonprofit organization with over 200 member US law schools, an innovative force pushing legal education toward change for the better. There are benefits to [CALI membership](#) for your school, firm, or organization. eLangdell® is our electronic press with a mission to publish more open books for legal education.

How do we define “open?”

- Compatibility with devices like smartphones, tablets, and e-readers; as well as print.
- The right for educators to remix the materials through more lenient copyright policies.
- The ability for educators and students to adopt the materials for free.

Find available and upcoming eLangdell titles at [the eLangdell bookstore](#). Show support for CALI by following us on Twitter ([@caliorg](#)), and by telling your friends and colleagues where you received your free book.

Editor Notes

Editor's note on modifications to the cases included in this book

In editing judicial opinions, I have maintained the original language and much of the formatting except as follows:

I have omitted most judges' names and other references to the case disposition that were not deemed relevant. I have corrected obvious non-substantive typographical errors, freely inserted or removed paragraph breaks and removed headers in many instances. I have indicated most substantive omissions with bracketed asterisks. Where asterisks exist without brackets they are found in the original. In some cases, I explain omissions, such as when I have removed a section of substantive analysis or reserved discussion for later in the course. I have indicated omitted citations and footnotes with brackets as per the legend below. In cases that cite extensively to the parties' briefs or trial record, I have sometimes opted to drop citations without signaling doing so in order to declutter the text. Any footnotes in the opinions are original to the opinions unless indicated as Editor's notes, but footnotes will not correspond to the same number as they did in the original citation. I have also tried to reduce visual clutter and reading time by generally cutting out parallel citations to legal authorities. The conventions adopted by different courts and in different eras mean the reader will see different editorial choices regarding the organization of judicial opinions and relevant authorities. Rather than painstakingly trying to convert to some artificially uniform presentation, I have left them largely as is.

[c]: indicates that a citation has been omitted [Letter is capitalized or not depending on whether it started a sentence]

[cc]: indicates that multiple citations have been omitted

[fn]: indicates that a footnote has been omitted

[fns]: indicates that multiple footnotes have been omitted

*** : indicates asterixes in the original

[***]: indicates omissions from published opinions

Acknowledgements

This casebook benefited from the efforts and helpful counsel of a dozen anonymous peer reviewers as well as the particularly generous guidance of Bernard Bell, Laura Heymann and Jennifer Wriggins. Professor Bell deserves special mention as the teacher who first introduced me to tort law and inspired in me a deep and enduring love of the field starting from when he called on me in my very first law school class. At CALI, Deb Quentel and Sara Smith have been a joy and a source of encouragement, supporting my vision for the casebook and exhibiting unearthly patience, competence and compassion throughout. Carly Zipper provided excellent research assistance in developing questions and working with students the first year the materials were in use. Mary Whisner and the Gallagher Law Library provided additional support and encouragement along with years of quirky torts stories that expanded my understanding and appreciation of the field. Dan Grove, Layth Stauffer and Clay Stauffer put up with several years of near-constant conversations at the dinner table about accidents, lawsuits and remedies with unfailing good humor; they even contributed hypotheticals and news stories as we embarked on what often felt like a household-wide journey into the depths of how tort law could be understood from a 21st-century perspective. Finally, I am indebted to my students from whom I have learned, and continued to learn, about how to teach tort law to this incredibly promising and bright new generation of law students. They both demand and deliver a great deal and this book seeks to rise to the urgency and idealism of their vision of what the law can be and do. May we continue to learn and transform the profession together.

Table of Contents

About the Author	i
Notices	ii
About eLangdell Press	iii
Editor Notes	iv
Acknowledgements	v
MODULE 1. INTRODUCTION TO TORT LAW	1
Chapter 1. A 21st-Century Overview of Tort Law	2
Chapter 2. Introduction to Negligence	18
Chapter 3. Introduction to Strict Liability	33
Chapter 4. Distinguishing Strict Liability from Negligence (Socratic Script)	44
Chapter 5. Introduction to the Intentional Torts: Protecting Property, Body, and Mind	58
Chapter 6. Intentional Torts vs Negligence (Socratic Script)	86
MODULE 2. INTENTIONAL TORTS.....	96
Chapter 7. Intent.....	100
Chapter 8. Revisiting Assault and Battery	114
Chapter 9. False Imprisonment	124
Chapter 10. Intentional Infliction of Emotional Distress (“IIED”).....	132
Chapter 11. IIED: A Deeper Dive (Socratic Script)	144
Chapter 12. Trespass to Chattels and Conversion.....	157
Chapter 13. Defenses Against the Intentional Torts	171
MODULE 3. NEGLIGENCE	195
Chapter 14. Negligence: Duty.....	197
Chapter 15. Duty As a Function of Foreseeability (Socratic Script)	202
Chapter 16. Negligence: Breach	265
Chapter 17. Negligence: Policy Considerations Regarding Duty and Breach (Socratic Script)	285
Chapter 18. Negligence Per Se and Res Ipsa Loquitur	310
Chapter 19. Negligence: Causation.....	346
Chapter 20. Negligence: Proximate Cause	382
Chapter 21. Negligence: Foreseeability in Duty and Proximate Cause Analysis (Socratic Script)	393

MODULE 4. DEFENSES, PRIVILEGES, IMMUNITIES AND LIMITATIONS	414
Chapter 22. Plaintiff’s Conduct	415
Chapter 23. Immunities	460
Chapter 24. Statutes of Limitation and Repose.....	505
MODULE 5. PRODUCTS LIABILITY LAW.....	513
Chapter 25. Developments in Tort Law and Early Products Liability Law	514
Chapter 26. Implied Warranty	521
Chapter 27. Express Warranty	536
Chapter 28. Strict Products Liability.....	550
Chapter 29. Product Liability Based on Dangerous or Defective Condition.....	554
Chapter 30. Design Defects (Socratic Script)	561
Chapter 31. Defenses to Products Liability	581
MODULE 6. DAMAGES	591
Chapter 32. Punitive Damages.....	594
Chapter 33. Compensatory Damages.....	599
Chapter 34. Statutory Caps on Damages (Socratic Script)	607
Chapter 35. Implications for Social Justice	624
MODULE 7. DEFAMATION.....	653
Chapter 36. Introduction to Defamation’s Elements at Common Law (Until 1964).....	654
Chapter 37. Constitutional Constraints	682
Chapter 38. Defenses and Limitations	720

MODULE 1. INTRODUCTION TO TORT LAW

Chapter 1. A 21st-Century Overview of Tort Law

The Origins of Tort Law

The purposes of tort law have expanded over the centuries of its evolution. In its earliest forms in England in the 12th century, tort claims provided a means of ordering civil society and keeping the peace. By defining certain conduct as wrongful and enabling a means of redress for harms caused by deviations from that standard, tort law reflected and helped shape social behavior and expectations.

It was the Industrial Revolution in England (roughly defined as the late 18th through early 19th century) that paved the way for the rise of modern tort law. Changes in manufacturing and transportation transformed the agricultural economy and brought sweeping changes to labor practices. Innovative technologies continued to be developed to meet the demands of operating efficiently at this new scale. Increasing mechanization in the industrialized workforce forced new patterns of behavior and exposed human bodies to increased risks of catastrophic harm. The rise of railway travel, likewise, brought a new wave of accidents—and accident law—both in England and in the United States, whose jurisprudence borrowed heavily from English law. While tort law first began to be recognized as a distinct field in England in the 18th century, in the U.S., tort did not consolidate into a recognized area of law until later in the 19th century.

Initially, workers found tort law's rigid strictures to be barriers to recovery. Various protective doctrines insulated employers from the costs of employee injuries and made it difficult for employees, and often their widows, to recover legally for injuries and death. Indeed, some have argued that the rise of negligence law was rooted in the legislative efforts to insulate businesses from liability that might otherwise attach more easily under a strict liability (or "no fault") standard. Under this view, negligence law developed partly as a way to support the growth of businesses whose operations could have been hindered by expansive tort liability in this era prior to the creation of alternative mechanisms for dealing with employee injuries. Ultimately, tort law played a critical role in increasing worker safety and in the early twentieth century, its changing rules helped give rise to our current systems of workers' compensation, private insurance and consumer protection law. In some respects, tort law both reflects the values of the jurisdiction that develops it and contributes to shaping behavior and values in the community it regulates.

In addition to its common law evolution, tort law in the modern era has taken shape from a significant amount of state and federal legislation. In the United States, the 20th century witnessed the growth of a culture of governance through agencies and statutes, sometimes referred to as the rise of the "administrative state." Many actions that might have been addressed through common law principles are now governed by state or federal statutes, administrative regulations or municipal ordinances. Consequently, studying tort law also provides a valuable exploration of the common law's interaction with statutory and administrative regimes.

Introduction to Studying Tort Law

Welcome to the study of tort law. The word tort comes from the Latin *torquere*, “to twist.” In Middle English, it meant “injury” —or the idea of twisting or turning that leads to harm—and in contemporary French it still means “wrong.” “Torts” are wrongful actions that cause some kind of harm for which the victims of the harm may seek legal relief. Torts are not usually wrongs arising from the breach of a contract. While there *is* a tort called “tortious interference with contract” (which is what it sounds like), and there *are* a few other instances where tort and contract law intersect, generally torts pertain to actions between parties who might have never made any sort of contract or promise to collaborate. A common remedy for breach of contract law is “performance,” or forcing the party to complete what they promised to do by contract. However, tort actions most often arise between strangers, not parties who signed a contract or made mutual promises. Relatedly, the typical remedy under tort law is compensation through money damages. Keep in mind as you launch your study of torts the different way remedies are redressed in this context of harms arising usually outside of any contract or promise. An important feature of the torts litigation landscape is the contingent fee arrangement: the plaintiff’s attorney takes the tort case in the hopes of winning it and receives payment only if the plaintiff wins. In such cases, the attorney commonly receives around a third of the plaintiff’s award.

Legally speaking, tort lawsuits are civil, not criminal actions, which means they are brought by private parties against other parties. As with almost every legal generalization, there are exceptions to the dividing line between tort law and criminal law. A driver who causes significant losses and harms at the wheel could be *guilty under criminal law* as well as *liable for negligence under civil law*. Different actions—or lawsuits—would be brought by different entities seeking different remedies, animated by different purposes and subject to different procedural and substantive rules. The introductory torts course will rarely dwell much on the tort/criminal intersection. Torts is a class that typically introduces law students to civil law and most professors focus accordingly.

Tortious conduct may involve physical harm caused to people or property by car accidents, machinery malfunctions, medical malpractice, trespass on land, false imprisonment, and assault and battery, to name the most common kinds.¹ Victims may also recover in some cases where there has been no physical harm, where they can show that the tortious conduct has caused harm to their reputation, dignity, privacy, mental wellbeing or, in a narrower subset of cases, when they have suffered because their family members or loved ones have been physically harmed.

¹ Echoing the earlier distinctions between civil and criminal law, note that civil assault and battery are torts, dealt with in private law, which may allow the victim to seek money damage for their harms or to stop future harms by the assailant. Criminal assault and battery are crimes, dealt with in public law, which may allow the state or government to prosecute and penalize the assailant. It’s important to keep these distinct because the elements necessary to prove that the conduct was criminal differ from the inquiry into whether the conduct was tortious. Additionally, the remedies and the burden of proof differ.

Effects of Contemporary Tort Law

In the modern era, the effects of contemporary tort law are hotly debated. The torts “system” is not some centralized agency with consistent and predictable rulings but rather a complex set of interactions between state laws—which vary greatly—and federal laws. In addition, agency regulations and constitutional limits further shape the contours of contemporary law. Partly as a result of this decentralization, amassing systematic data is challenging if not impossible. Moreover, most cases settle in private agreements, never rise to full legal disputes in the first place, or are handled as a matter of insurance and thus remain “off the radar” of legal cases and published opinions that can be tracked and studied.

Nonetheless, there is some consensus that tort law continues to play a role in disciplining the behavior of manufacturers, corporations and even government entities who may otherwise have incentives to cut costs on safety measures. Class action lawsuits brought to help those who have been injured, say by chemicals (like asbestos or diacetyl) or products (like tobacco, baby powder or certain breast implants) attempt to compensate and protect those who have suffered due to conduct that caused harm on a vast scale. These lawsuits arguably play a deterring role and encourage entities to adopt a safer calculus in their risk assessments as they contemplate their choices for the future. However, the extent of that deterrence is debated and difficult to measure empirically. Once again, there is some consensus that almost all entities that operate on any significant scale anticipate and accept some liability as a cost of doing business. They will usually be forced to adjust their liability projections and behaviors after major litigation, for both economic and legal reasons.

Consequently, tort law disciplines actors by incentivizing them to determine and maintain optimally safe choices and by forcing them to internalize the costs of any injuries arising when they have failed to do so. Yet tort law seeks an *optimal* level of safety, not 100% protection against all possible risks. If companies could guarantee perfect safety, they would probably be taking such burdensome precautions that they would be *overdetering*, that is, behaving in a way that was not necessarily justified by efficiency concerns and likely not required by morality concerns. This is especially the case if in adopting excessive precautions, entities chose to pass on the added costs to consumers. Under the economic (efficiency-maximizing) theory, tort law operates in light of a calculus that balances the kinds of harms likely to flow from certain conduct against the costs of refraining from that conduct or taking precautions to minimize its ensuing risks. Under the corrective justice (compensation or recourse) theory, tort law seeks to vindicate those that have been harmed. But even in that view of tort law, rights and duties are always relative: how will they affect all the relevant stakeholders?

Because tort law is so malleable and diverse by jurisdiction, there are regularly opportunities to reflect on the law’s present and future state and to consider the rights it recognizes as well as the values it expresses. What will society look like if cases develop in one way versus another? How faithful is the law not just to precedents and legal history but to the future our society wishes to develop?

Thus far, this Introduction has described tort law mostly in terms of its effects on industrial actors and customers or consumers, presuming injuries that are physical. Yet in addition to structuring some of the risks and protections around corporate behavior and consumer safety, tort law plays an important role with respect to intangible injuries in our information-rich society. In protecting against misrepresentations, fraud and false speech, for example, tort principles underpin the laws of false advertising, securities regulation, product warnings and labeling, and defamation. In your later years

as law students, you will likely choose to pursue at least some classes that are rooted in part in tort law, such as environmental law, intellectual property law, corporate governance, insurance law, employment discrimination, and agency law, among others. In these upper-division areas, you will find that many of the key concepts you learn in your first year remain relevant, such as how courts and policymakers identify, define and balance rights and duties.

Tort law also plays a significant role in the sphere of our social lives. In providing compensation under wrongful death statutes and compensating for loss of consortium when individuals lose family members and spouses, tort law clearly signals certain values about the primacy of family in society and the importance of emotional ties to others. In allowing recovery for a wrongful sterilization or the loss of a fetus and in subordinating injuries to property and pets below injuries to humans, tort law signals certain values. With regard to defamation claims, tort law similarly reveals choices embedded in the system. For instance, certain categories of allegedly defamatory statements permit the plaintiff to avoid proving harm. Until as recently as 2020 in the socially progressive state of New York, one of these categories was still homosexuality—along with criminality, professional incompetence and loathsome disease. While courts and legislators make efforts to be or to sound neutral, tort law nonetheless displays certain choices and values. Consequently, tort can become a conduit for social change or an impediment to it.

Systemic Biases in Tort Law: Physical versus Emotional Harm

In many respects, tort law's role in regulating—and perpetuating—certain kinds of discrimination has not been the focus of scholars and law professors. Much of twentieth-century tort law has centered on strict liability and negligence, which is to say on the law of accidents. Various doctrines predicated recovery on proof of physical harm. Historically, this requirement had the effect of making recovery for emotional distress very difficult other than when it accompanied physical injuries. Contemporary tort law has been slow and reluctant to recognize injuries that are purely emotional. Indeed, there was initially thought to be no way to recover for “purely emotional” harm. Tort law's historical reluctance to allow recovery for emotional harm and its insistence on proving physical harm both reflected biases that can now be seen to have fallen disproportionately on women. There was a corresponding lack of scholarly attention to some of the kinds of harms suffered by women and people of color. To be sure, courts applying tort law's doctrines might have felt bound by precedents and rules but scholars need not have ignored or marginalized injuries resulting only in emotional harm. Yet they did; the exaggerated emphasis on accidental harms and physical injuries goes beyond courts alone.

In their now-germinal book, *The Measure of Injury: Race, Gender, and Tort Law* (NYU Press, 2010), Martha Chamallas and Jennifer Wriggins have shown that the focus on negligence came with a corresponding devaluation of the intentional torts. This lopsided account of tort law has been reflected in law school syllabi, legislative agendas and efforts by jurists who study and “restate” or catalog the law, as well as by those who would attempt to reform tort law. Chamallas and Wriggins demonstrate how treating intentional torts as secondary in importance has systematically minimized the suffering of women and people of color.

A revolution in the courts in the second half of the century led to a patchwork of rules created to permit some claims associated with emotional distress under particularly heightened circumstances and

narrow cases. A new tort, intentional infliction of emotional distress, was created out of an older cause of action based on “outrage.” The emergence of claims for recovery based on purely emotional distress generated some greater attention to the intentional torts, but there remains much work to do in recognizing the structural biases inherent in tort law.

In addition to the rigid distinctions between physical and emotional harms, for instance, tort law has also treated certain categories of behavior and certain entities as immune from tort liability. In some cases, this has meant that pathological or harmful behavior routinely went unrecognized by tort law. For instance, survivors of domestic violence rarely had viable claims in court even though they would have had winning battery, assault and other intentional torts claims had their assailant *not* been a romantic partner. Regrettably, this state of affairs has not changed all that much and domestic violence cases often present genuine challenges for both civil and criminal law.

Skeptics of this account might reply that tort law was never intended to remedy marital or domestic controversies, which is true. Indeed, when we inherited English tort law, interspousal immunity—a ban on spouses’ ability to sue each other—came along with it. The renowned 18th-century English jurist, William Blackstone, set out the rationale for that immunity:

By marriage, the husband and wife are one person in law: that is, the very being or legal existence of the woman is suspended during the marriage, or at least is incorporated and consolidated into that of the husband: under whose wing, protection, and cover, she performs everything; and is therefore called in our law-french a *feme-covert*, *foemina viro co-operta*; is said to be covert-baron, or under the protection and influence of her husband, her baron, or lord; and her condition during her marriage is called her coverture. Upon this principle, of a union of person in husband and wife, depend almost all the legal rights, duties, and disabilities, that either of them acquire by the marriage. ... If the wife be injured in her person or her property, she can bring no action for redress without her husband’s concurrence, and in his name, as well as her own: neither can she be sued without making the husband a defendant.

Blackstone’s explanation illustrates how a woman’s legal personhood was effectively dissolved into her husband’s under earlier common law. The two were not commingled in such a way as to make one interchangeable for the other, each with rights to exercise equally. Instead, the husband absorbed her legal personhood and was required to act as the legal person on her behalf if she wanted to exercise legal rights. For this reason, it was thought to be illogical for an entity to ... sue itself. (Intraspousal immunity was slowly abandoned, one state at a time, throughout the 20th century, partly because of the sexist rationale.)

Be that as it may, the effect of excluding certain kinds of harms and including others at any given point in time sends signals about the values that are embedded in the legal regime and the interests it seeks most to protect.

Tort Law’s Systemic Biases (Gender, Race and Intersectional Identity Effects)

Tort law may have begun to wrestle with gender and attendant sociological differences, but gender is only one dimension to identity. The challenge is that the impact of injuries lands intersectionally, as a

function not just of gender or of race but also of ability, sexual orientation and class, among other identity markers. In the visionary work of Kimberlé Crenshaw, *Mapping the Margins: Intersectionality, Identity Politics, and Violence Against Women of Color*, 43 Stan. L. Rev. 1241, 1249 (1991) Crenshaw writes of ways that different dimensions of identity may typically “intersect” to produce particular experiences of vulnerability. The problem is structural rather than personal or individual: “Intersectional subordination need not be intentionally produced; in fact, it is frequently the consequence of the imposition of one burden that interacts with preexisting vulnerabilities to create yet another dimension of disempowerment.” Exploring the systemic biases in tort law requires grappling with the intersectional effects of its rules and rulings and considering the fundamental principles in tort law with a fresh eye.

Thankfully, there has been some progress on issues of social justice. Yet there is no doubt that tort law continues to reflect signs of deep structural bias. Studies have shown that race and gender biases enter into damages awards in ways that ought to be concerning for policy makers seeking a more equitable legal system. A recent empirical study using mock jurors demonstrated that “[t]he dollar awards for the injuries suffered by black plaintiffs were lower than awards for the same injuries experienced by white plaintiffs,” suggesting that race, and implicit racial bias, are bound up with how the legal system evaluates both responsibility and harm. Jonathan Cardi, Valerie P. Hans and Gregory Parks, *Do Black Injuries Matter?: Implicit Bias and Jury Decision Making in Tort Cases*, 93 S. Cal. L. Rev. 507 (2020). Actual damages awards have been also measurably lower in patterns that reflect racism and sexism. See, also Jennifer B. Wriggins, *Torts, Race, and the Value of Injury, 1900–1949*, 49 How. L.J. 99, 101–03 (2005); Jennifer B. Wriggins, *Whiteness, Equal Treatment and the Valuation of Injury in Torts, 1900–1940*, in *Fault Lines: Tort Law and Cultural Practice* (David Engel & Michael McCann eds., Stan. Law Books 2009).

In fact, some have argued tort law might be part of the problem. According to professors Ronen Avraham and Kimberly Yuracko, “not only does tort law’s remedial damage scheme perpetuate existing racial and gender inequalities, but also it creates ex ante incentives for potential tortfeasors that encourage future targeting of disadvantaged groups.” *Torts and Discrimination*, 78 Ohio St. L.J. 661, 666–67 (2017). Avraham and Yuracko argue that tort law can distort behaviors merely in *anticipation* of liability, thus causing further discrimination.

Tort law has traditionally not been taught in law schools in ways that take account of its systemic biases. Yet various doctrines and limitations that tort law treated as neutral had disproportionate effects that were anything but neutral in whom they most impacted or protected. Courts rarely acknowledge demographic information about the parties in a given dispute unless some aspect of their identity is central to litigation. Law school historically has worsened the problem by treating the law as “perspectiveless” or neutral. Kimberlé Williams Crenshaw, *Foreword: Toward a Race Conscious Pedagogy in Legal Education*, 11 NAT’L BLACK L.J. 1 (1989). Yet this “neutral” or “colorblind” way of approaching the law often has the effect of ignoring, or even erasing, the discriminatory structures and principles shaping tort law, whether the issues involve sexism, racism, ablism or other forms of structural inequality.

Correcting the various biases will require *seeing* them first. Our legal system operates by stare decisis, that is, by building on and usually following precedents. In turn, this means that the lawyerly mind is trained to identify and gravitate towards tried and true authorities. In keeping with that inclination, perhaps, the legal academy has tended to teach the same torts cases, thus entrenching not only particular

cases but to some extent, also traditional viewpoints. Correcting tort law's biases may require a revisionist approach to tort law that begins with a reset.

It seems urgent in our era—and hardly out of the mainstream—to call for reexamining tort law's biases. Theorists associated with various “critical” positions have long called for such a focus on all areas of law. Valuable contributions by critical race theory, critical feminist theory, critical legal studies, “LatCrit” as well as disability crit have laid a foundation for this work. But the work of reenvisioning tort law is not constrained by any one ideological approach, or it ought not to be. It is of concern for all of us engaged in teaching, learning about and practicing tort law.

Consider that tort law was shaped, for a very long time, only by white adjudicators and white jurors, navigated only by white male lawyers and chronicled by white male scholars. Even as that began to change, it remained a system that continued to benefit white cisgendered able-bodied people, especially men and those with more resources and social and cultural privilege. Calling that out does not require any particular political or methodological affiliation. And not calling it out should no longer seem like a defensible option.

The good news is that tort law is capable of incredible nuance, flexibility, and particularization. Those qualities are what can make it frustrating for law students seeking a single hard and fast rule. Yet they are also the very things that make tort law lively and fun to study as well as being capable of significant systemic change.

Tort Law's Dynamic Nature Depends on—and Changes with—Culture

Tort law is laudably dynamic; it can and does change in response to changing perceptions of both identity and justice. This is why it is especially important for students first learning torts to understand this legal area as one that can play a role in either entrenching various forms of inequality or helping to minimize them. In delineating the behavior our society deems acceptable or out-of-bounds, tort law reflects and defines our social relations. As such, the study of tort law offers students the opportunity to think deeply about their values and belief systems. And it offers them an opportunity to carry into their professions the desire to participate in changing the law as the arc of justice bends, we hope, towards greater justice.

Tort law provides an excellent introduction to the common law precisely because of its capacity for adaptation. It is flexible and changes over time in response to sociocultural, economic and technological pressures. It is flexible by design: several key doctrines use open-ended standards (like “reasonableness”) and disputes often require fact-sensitive assessment. This means that tort cases may be slow or cumbersome or expensive to litigate. The upside is that the law can be tailored to each particular situation, thus allowing for dynamic change that can be harder to achieve when using legislation to regulate behavior.

Tort law's principles are applied in ways that are *contingent* (or depend for their application) on the culture and historical moment of those who apply them. That means that tort law's standard of “reasonableness”—which plays a starring role in negligence but is also embedded in various other doctrines—reflects particular values and perspectives at a given place and moment in time.

A Thought Exercise on “Reasonableness”

Imagine you are a judge and you have been asked to make a decision about whether to allow a case to move forward in an action over a car accident that occurred after the brakes on the defendant driver’s car failed. The driver had seen a notification on the car’s dashboard which included a red light and the words: “brakes require service” This notification came four days prior to the accident and remained on during the intervening time.

At this point, you’ve got only the barest amount of information based on some preliminary exchanges with opposing counsel. Ordinarily, a driver has a duty to exercise reasonable care in everything they do, including in relation to the car itself as well as driving and any risks to others their conduct may cause. You will therefore need to evaluate the reasonableness of the defendant’s actions, and specifically, whether it was reasonable *not* to have serviced the brakes on the car when the brake light had been on for four days and the brakes failed on day five, causing an accident which caused significant injury to the plaintiff.

What would you want to know in order to assess whether this plaintiff behaved as a reasonable person would under the circumstances?

Picture the reasonable person. Who appears in your mind?

What is the person’s race, gender, ethnicity and age? Did you imagine a person with a disability? What is the person’s cognitive level? What do you presume about this person’s education level and professional status?

There are two points to engaging in this thought exercise. The first is that **the assessment of reasonableness is often highly factual and requires balancing**. If the car is new and has never malfunctioned before, four days may be very little time from a routine service light’s first appearance to the brake’s failure. If the car is unreliable and the light simply one more sign that it requires maintenance, then waiting four days may seem less excusable. If the car owner knows that service lights come on routinely when the car hits certain mileage numbers, it may be even more defensible to have waited to schedule a routine checkup. Would it matter to you how difficult it was for the driver to make time to get it to the repair shop? What if the driver was a single parent holding down two jobs and they had booked a service appointment for the first day they were off work, which was two days later than the accident? What if the driver was a collegiate athlete involved in exams and training and hadn’t wanted to distract themselves from those goals, thus postponing the maintenance? What if the driver was forgetful and kept meaning to fix the brakes when they saw the light on the dashboard but would forget to make a plan to do so upon leaving the car? What if this forgetfulness were caused by a form of illness, disability or neurodivergence?

The second point is that **tort law’s “reasonableness” standard is highly constructed**. We ask jurors or judges, sitting as factfinders, to determine it in each case because it can and must be considered in light of all the circumstances. But that does not make it impartial; humans bring their implicit biases and cognitive limitations to the task of determining what is reasonable. As you study tort law, pay attention to ways in which the very idea of reasonableness embeds cultural values or reflects ageist, sexist, ableist, racist or otherwise outdated and harmful notions. Part of changing the law is learning to identify hidden defaults and highlighting their impact.

In our era, tort regulation can be a lightning rod for political and cultural controversy. Tort actions are commonly brought by individuals against other individuals or entities, but their sociocultural context matters and many rulings can have broader impact beyond their individual verdicts. Our approach to tort law will be to ground cases in their sociocultural context and potential impact as we are reading and seeking to apply or distinguish them. I encourage you to think about torts and tort cases “in the real world” not as ancient legal precedents far removed from your experience as a law student and aspiring lawyer.

As your knowledge of this area increases, it may interest you to think about how tort law helps to enforce and balance social and economic norms of fairness and responsibility. For some of us, tort law becomes most interesting when considered as a form of civil justice. Consider, too, the ways in which the law fails to achieve the proper balance or justice, in your view, and how and why that might be.

Purposes and Theories of Tort Law

Purposes. In one sense, merely describing the purposes of tort law is challenging; the field is politicized and animated by sharp philosophical disputes over how to define its scope and purposes. However, the following are noncontroversial starting points: Tort law exists to “(a) give compensation, indemnity or restitution for harms; (b) determine rights; (c) punish wrongdoers and deter wrongful conduct; and (d) vindicate parties and deter retaliation or violent and unlawful self-help.” Restatement (Second) of Torts § 901 (1979)

Tort theorists have argued over whether the purposes of tort are better understood in terms of (1) the **positive legal rights of the victim** (and *compensation* they may be owed as well); (2) **the rights and duties of members of society** to one another (and thus *fairness* to all individuals); (3) **limits on the rights of those who engage in risky conduct or carelessly cause accidents** (and the *deterrence* tort law imposes on them); and (4) the potential benefits to victims, tortfeasors and members of society if the costs of prevention and remuneration are maintained at “optimal” levels (which reflects a commitment to efficiency). Indeed, some casebooks and approaches to tort law focus very heavily on the economics of tort law, consistent with the views tort law’s core purposes are *efficiency* and compensation. Others may take a more philosophical approach, grounding rights and duties in different theories of justice, highlighting tort law’s purposes of fairness and deterrence.

These terms and theories could be defined at great length and still seem overly simplified to some and mysterious to others. This text does not purport to be a substitute for an in-depth treatment of jurisprudence (which is the study of theories or philosophies of law). But it will use these terms—**efficiency, compensation, fairness and deterrence**—repeatedly throughout the text, and to ensure that readers understand them, it is helpful to define them in terms of theories of justice with a grounding in tort law.

Theories. Tort law is commonly framed in terms of several theories of justice: **procedural justice** (with an emphasis on fairness, notice and transparency); **distributive justice** (balancing compensation, loss-spreading and efficiency concerns); **retributive justice** (seeking to punish and deter wrongdoing); and **corrective justice** (providing compensation to the victims of tortious wrongdoing). There isn’t a perfect overlap between the four sets of terms since, for example,

distributive justice balances both compensation and efficiency, but it is still helpful to understand the philosophical underpinnings that attach to the 20th-century development of tort law.

Procedural justice focuses on the transparency and fairness of processes by which rights are created and enforced. As such, it is primarily concerned with fairness. Designing a fair and balanced process is not a guarantee of fair outcomes because parties are not equally situated before the law; decisionmakers are not perfectly impartial or incapable of error; and many laws are outdated and lag behind contemporary views of fairness. Nonetheless, our legal system stakes significant importance on making an attempt at procedural fairness.

For example, the idea of “notice” plays an important role in many tort doctrines, which is a nod to procedural justice and reflects the idea that it seems fairer to hold someone responsible when they were “on notice,” if they *knew* or *should have known* that some harm was likely to happen and still took whatever action they took.

Distributive justice concerns allocating resources and liabilities fairly based on some pre-set understanding of the right to a “fair share” of both the benefits and burdens. The values driving that distribution may change over time, by jurisdiction, or in connection with political administrations. In our era, the driving concerns behind distributive justice have primarily been economic: who *can* bear the costs of liability and who *should* bear the costs of preventing accidents given the ability of various actors to insure against injury or to internalize the expenses associated with both injury and prevention? Indeed, contemporary tort law has been strongly influenced by late 19th-century philosophers who advanced utilitarian theories of law, as well as 20th-century scholars and judges working in the law-and-economics tradition. Such theorists often seek the “cheapest cost avoider”—the entity best positioned to absorb the costs of preventing harm and compensating for it when preventions fail—so as to maximize efficiency regardless of moral culpability.

For example, the doctrine of strict liability (liability without fault) has evolved in ways that allow parties to engage in behavior that they know in advance will be risky, such as blasting with dynamite prior to construction. However, merely engaging in the action will cause them to be liable for harms they cause through their actions, which allows them to internalize the costs of precautions and to make their behavior as safe and efficient as possible. Or at least, that’s one theory of how it works.

Retributive justice is more commonly associated with criminal law, which seeks to punish wrongdoers. Tort liability is not typically defined so as to impose suffering or punishment on the wrongdoer. A tortfeasor may be liable in tort even when morally not blameworthy but merely careless. Likewise, an actor may be liable even when behaving carefully but nonetheless causing harm by taking an action to which the law applies strict liability.

In rare or egregious cases, however, courts may award punitive damages that do reflect theories of retributive justice, namely, that the wrong was so significant the wrongdoer deserves to suffer.

Corrective justice frames tort law as a form of moral or ethical obligation, structured in terms of first- and second-order duties. First-order duties specify particular behaviors (such as driving reasonably or refraining from trespass). Second-order duties arise if an actor breaches their

first-order duties. Accordingly, second-order duties are duties to repair or make the injured party “whole,” thus *correcting* the tortfeasor’s wrongs and compensating for the losses their breach of first-order duties caused. Corrective justice is oriented around the duties owed by the defendant to those they injure because its central logic is the “making whole” of the plaintiff.

For example, most plaintiffs sue to recover compensatory damages so that they will be “repaid” for the costs they incurred in connection with the defendant’s wrongdoing.

One problem with this theory arises when injuries are irreparable; under such circumstances, tort law may still allow a victim to recover, thus broadening the right of recovery to the suffering caused by the injury even when the harm is irreparable, that is, something that cannot be “corrected.” It is also worth noting that the very idea of “wholeness,” when applied to the body, hints at an ableist understanding of selfhood. Wholeness, of course, is not simply a literal reference to body parts; it applies to compensation for pain and suffering and medical bills and many other ways in which catastrophic injury can derail and burden one’s regular way of life. Hence it is a good idea to keep the literal and figurative uses of “wholeness” conceptually distinct.

A related theory of tort law is that of **civil recourse theory**: when a person suffers a particular kind of harm, they have a right to bring a civil action against the one who harmed them and seek recovery. Yet unlike corrective justice, the duty to repair does not justify civil recourse theory. Rather, the individual whose right has been invaded merely has a right of recourse, that is a right to have their legal claim evaluated. The distinction may seem purely academic, but it can have important implications for how we conceive of the nature and scope of the plaintiff’s possible rights and remedies. Proponents of both of these approaches commonly treat tort law as containing moral obligations (that is, they cast it in **deontological terms**). Tort law expresses these moral values through rules and outcomes, and efficiency concerns may be subordinated accordingly rather than prioritized the way they are in the economic account of torts.

Scholars in the field have produced elegant refinements of each of the theories briefly sketched above; whole books could be and have been dedicated to each, in fact. There are also deep disagreements about the justifications of tort law that are much elaborated elsewhere. The debate between the two dominant views of (1) “corrective justice or civil recourse” and (2) “the efficiency or utility-maximizing account” is so longstanding, in fact, it has “shown signs of being tired [...] midway through its sixth decade at the very least[,]” and has prompted “increasingly prominent effort of scholars across generations to move beyond it, either by declaring a truce or by asserting a third model for the field altogether.” Nathaniel Donahue & John Fabian Witt, *Tort As Private Administration*, 105 *Cornell L. Rev.* 1093, 1094–95 (2020).

A recent synthesis of tort theories has argued that “morality and efficiency are not mutually exclusive theories of tort”; instead, “tort law operates as a vehicle through which communities perpetually reexamine and communicate their values, encouraging individuals to coordinate private relationships without undue state involvement. In short, the goal of tort law is to construct community.” Cristina Carmody Tilley, *Tort Law Inside Out*, 126 *Yale L.J.* 1320, 1324 (2017). The approach in this casebook most resembles Tilley’s view, of tort law as a means of constructing communities, a force that is legal

and social and psychological, and one which can be studied through law but also through economics, sociology, anthropology, and various theories of identity.

To learn the basic contours and doctrines of tort law you need not reconcile deeper conflicting theories, of course, but it is helpful to gain at least an introduction to the theories that are underpinning the way tort law was created, has developed, and continues to evolve. When the materials refer to these first four purposes of tort law—**efficiency, compensation, fairness and deterrence**—you will now have at least a preliminary sense of their origins and interconnections.

Check Your Understanding (1-1)

Question 1. A court’s opinion includes the following reasoning: “[T]he imposition of liability should deter negligent conduct by creating incentives to minimize the risks and costs of accidents.... If negligence is the failure to take precautions that cost less than the damage wrought by the ensuing accident [c], it would be unfair and socially inefficient to assign liability for harm that no reasonably-undertaken precaution could have avoided.” *People Exp. Airlines, Inc. v. Consol. Rail Corp.*, 100 N.J. 246, 266 (1985)

Which of the four forms of justice does it most seem to reflect?

An interactive H5P element has been excluded from this version of the text. You can view it online here: <https://saidtorts2d.lawbooks.cali.org/?p=24#h5p-1>

A More Inclusive Approach to Tort Law

The classic accounts of tort law do not typically lay out racial and social justice as a goal, per se, the way efficiency, compensation, fairness and deterrence are routinely cited as the core reasons for the system. One reason for this is that tort law has been treated as though it is neutral in application, perhaps as a concession to anti-discrimination laws and nationwide efforts to make the law more equitable or at least constitutional. Indeed, in the modern era, courts adjudicating torts disputes often explicitly sought to proceed as though the law were “color blind” and gender-neutral, preferring to not take any categorical differences into account. Thus even doctrines that had once been helpful to some vulnerable groups weakened: “[g]ender and race have disappeared from the face of tort law. The old doctrines that explicitly limited recovery exclusively to one gender have been either abolished or extended on a gender-neutral basis.” Martha Chamallas, *The Architecture of Bias: Deep Structures in Tort Law*, 146 U. Pa. L. Rev. 463 (1998)

In the last two decades, a growing volume of scholarship considers the intersection of civil rights and tort law and builds on various philosophical theories of law to consider how factors like race, gender,

social class, ability and sexual orientation may all play into the tort system's rights and duties. Yet casebooks are typically slow to take scholarly changes into account. This casebook's approach to tort law deliberately frames **social justice** as one of tort law's goals, even if it does so aspirationally, building on the work of scholars who have called for a more inclusive and sociologically informed account of tort law. If we take seriously the notion that tort law exists to remedy civil wrongs which the law has defined as such, it seems important that we define those wrongs in terms of what we know in our present moment, based on sociological, psychological, cultural and empirical evidence.

In the 21st century, we know that many laws fall with disparate impact on vulnerable communities and individuals. That's why this book begins with the premise that tort law can be envisioned as a mechanism for providing greater access to civil justice or a means of perpetuating civil injustice. In practice, the law might land somewhere in between those two binary choices but conceptualizing it in this way from the start can provide a capacious and progressive vision toward which to advance. Only by understanding how tort law "works," when it fails, and what it means for it to "fail" can we collectively work towards improving the system. Readers of the book do not have to share the same definitions of *what it means for laws to work or fail*; nor need they agree on what it might mean to *improve the system*. But engaging in dialogue on those questions while you're learning substantive doctrines will greatly enrich your understanding of the law and deepen your ability to analyze and apply it. It may also make the experience of learning the law more fun and rewarding. That's the hope, anyway.

The cases selected for our discussion are designed to give you a sample of the kinds of wrongdoing tort law does (and does not) redress, as well as the kinds of legal and policy considerations courts use in the course of their adjudication. They are also selected to encourage you to think about the balance of rights and duties in the world; tort law is relational. A person has a right, in relation to another person, to be free from the foreseeable harms that second person would carelessly cause to happen to the first. Put another way, that second person has a duty to take reasonable precautions to avoid causing foreseeable harms to the first person (and to others who could be harmed). That sounds easy enough, in the abstract, and it's often cited as a first-order principle: where the law creates a right, the law also creates a duty. But it is often not all that clear what that actually means as applied to facts in the world, which is a complicated, messy place in which human actors don't have perfect foresight and often make mistakes. This is one of the central challenges courts face as they attempt to strike a reasonable balance and develop and apply fair rules over time.

Challenging Subject Matter & Studying Tort Law

Because tort law is so situated in the "real world," most cases focus heavily on factual questions with sometimes quite complicated technical issues. You might find yourself having to pay close attention to map out the facts or to draw a diagram for yourself so that you can understand how a court describes, for instance, the angle of collision between a train and a car or pedestrian. Likewise, you may find yourself struggling to make sense of the theories of causation when a victim is seeking relief from harm that ensued from a chain of events, or from a combination of multiple factors. Sometimes tort law is quite gory, and if there is any law school class that needs a trigger warning, it really might be this one: there will be train accidents and severed limbs; parents claiming emotional distress after watching their child suffer in agony (perhaps even die before their eyes); there will be fires, and burns,

and medical procedures gone wrong that might make you squirm with discomfort just reading the facts. There are also dignitary and privacy harms that can be upsetting whether the conduct in question features sexist, racist, ableist, or otherwise hateful language or actions, or whether *the court itself* uses terms or rhetoric that are dismayingly biased even as it speaks in the voice of our country's justice system.

This casebook's selections feature some challenging subject matter. The choice to center issues of racial and social justice stems from the belief that sweeping things under the collective rug—or pretending that our civil justice system isn't sometimes a part of the problem—is a recipe for moving backwards in terms of greater equity in our country, rather than moving forwards. However we define “moving forwards,” that's the better direction to conceptualize as we bend collectively towards justice.

The Textbook's Terminology

There are three terms you need to understand from the outset, as they are critical to the perspectives on tort law offered here and they'll be used throughout this casebook. When you read a case, you'll often be asked what it holds. It's critical to be able to distinguish the parts of an opinion that are most meaningful, including which facts, if altered, could affect the outcome. It's also important that you be able to characterize the case analytically, that is, *descriptively*, and evaluate its reasoning. I believe it's also helpful to be able to evaluate the case in terms of how it makes you feel, that is, to understand it *intuitively*. Identifying your own intuitions about the law can help you in the identity formation that takes place in law school as you're refining and revising your values and ideas about the law. You may find yourself grudgingly agreeing that an outcome that seems correct as a matter of policy, that is, an outcome that seems *normatively* correct, nonetheless feels dissatisfying or unfair. In some cases, your intuition may point in one direction while your normative opinion points in another. A descriptive approach to the law seeks to interpret or explain existing law while a normative approach to the law seeks to critique, justify or reform existing law. (There are, of course, some overlaps between the various approaches but as a starting proposition, it is important to try to maintain a distinction.)

You also need to be able to analyze and describe the law dispassionately, whatever you feel about it intuitively or normatively. It may seem “touchy-feely” to ask you about your intuitions and not all law professors will do so. However, being able to acknowledge and validate your own intuitions and disaggregate them from your analysis is an incredibly powerful way to hone your analytical skills. You need to be able to answer questions about the black-letter law descriptively and accurately (to pass the bar, to predict likely outcomes and counsel clients). And you ought to be able to think about the normative implications of the law as you learn it; that's what drives home how much your legal education matters and what differentiates law school from a bar-exam preparation class. Tuning in to your intuitions can also make it easier to manage the sometimes-challenging subject matter you'll encounter in tort law. We are heading into the law of accidents and intentional harms and while it will often be lively, it is occasionally tragic or bloody or dehumanizing or all of the above.

Here's a summary of these three approaches to discussing the law:

- **Intuitive:** *how you feel* about the facts or ruling; this way of approaching cases is familiar, even without a legal education

- **Descriptive:** an accurate analytical statement of *what the law is or does* in a given case, which requires learning how to read a judicial opinion and may require understanding the context or case law simply to identify the correct legal rule
- **Normative:** a statement of *what the law ought to be*, in your opinion, *and why* based on policy factors and legal considerations you'll learn and gain practice discussing throughout the course

Not all professors use exactly the same terminology or emphasize these as centrally but they will all expect you to be able to shed intuitive modes of thinking and state the rule of a case descriptively without conflating your normative evaluations at the same time. Law school requires that you routinely differentiate the “is” from the “ought,” in other words. Whatever the terms anyone uses, learning to distinguish between intuitive, descriptive and normative modes of analysis is critical to your success in law school, especially in your first year as you are learning how to “think like a lawyer.”

Differentiating Negligence, Strict Liability and Intentional Torts

Most torts casebooks focus on either negligence or intentional torts as a means of introducing students to torts. Intentional torts are typically considered to be “easier” to understand because they are a bit more black-and-white whereas negligence is an area with a lot of “gray” or conceptually less crisp doctrines. Even this framing, however, may reflect the overemphasis on negligence that has historically informed legal education. There can be considerable complexity in aspects of the intentional torts even though it's true that they have qualities that can make them easier to teach and learn at a superficial level.

Our approach in this first module gives you a cross-cutting look at the three primary regimes of tort law all at once: **negligence** (fault-based), **intentional torts** (intent-based) and **strict liability torts** (no-fault based). This approach helps you gain an overview view of what it is you're going to be learning *to do* with what you learn.

One of the things law school most trains you to do is apply your knowledge effectively. It's not just a matter of gaining greater knowledge but **learning how to apply it judiciously**. Another thing law school does is train your brain to sort things quickly. You're going to be asked over and over again to take a messy fact pattern and distill it down to a rule or prediction. How you distill it down in torts is partly a function of what you know about these three systems and their purposes and limitations. When you hear about **issue-spotting exercises**, for example, you're being asked to learn rules and apply them to facts quickly. The speed isn't the point as much as gaining sufficient practice and comfort so that you can use this skill in real-time, as though you were in court or speaking with a client or working on a deadline under pressure. When you see a torts fact pattern, you will learn automatically to begin to sort things into buckets, by regime, by doctrines you know, and by other factors (such as jurisdiction and available defenses). This introductory approach gets you to start thinking like a lawyer by learning to spot and sort different kinds of torts regimes from each other.

You may understandably be anxious to learn the individual elements of each of the torts and get into the doctrinal weeds. However, by approaching the three regimes in this way, you will gain altitude over the whole ecosystem before we drop down into the forest and start studying the trees up close. You will learn why we use different regimes, what the impact of that decision is from a policy

perspective and why the regimes require different standards of culpability and different evidence. You will also see commonality and differences in the kinds of interests protected and the kinds of conduct protected against. Two main questions guide our inquiry throughout this first module:

What sorts of conduct does the law seek to regulate here, and why?

What sorts of interest does the law seek to protect here, and why?

We begin with negligence, which is the core area for most 1L torts courses.

Chapter 2. Introduction to Negligence

One significant subset of tort law concerns negligence, which usually consists of accidental or careless wrongdoing that results in harm. Negligence is thus largely concerned with injuries or damage inflicted through failure to take certain ordinary precautions. Negligence must be distinguished from the two other regimes you will study. Intentional torts concern tortious behavior that meets a requisite level of intentionality whereas negligence refers to wrongdoing better characterized as accidental or careless than intentional. The domain of strict liability law attaches liability categorically to certain behaviors, no matter whether the actor was at fault in any way. What defines the domain of strict liability is whether a legislature or court has decided that a particular behavior belongs in this category. Defining what it means “to be at fault,” instead, falls to negligence law.

The test for determining negligence is whether or not the parties’ conduct was “reasonable” under the circumstances. This is known as the “reasonable person” standard. Tort law does not anticipate that actors will behave perfectly, or even expect that they will try to do so. The theory is that it would be costly and unfair to require that people move through the world never causing any harm; if people were liable for every possible harm they might cause, they might stop doing many things that are socially valuable but nonetheless involve some amount of risk. Instead, tort law imposes a reasonableness standard which depends on the judge or jury’s best retrospective assessment of how a “reasonable person” would have behaved under the same circumstances.

Over time, negligence law has proven to be adaptive to social, economic and technological change, since the standard—whether the conduct that produced injury was *reasonable under the circumstances*—can change over time and the legal outcome usually depends on the facts of the specific case. Reasonableness is highly constructed, of course; what it means may well be expressed as a function of ability, class, gender, sexual orientation and race. Yet, with few exceptions, tort law uses a “one-size-fits-all” approach to reasonableness.

The standard negligence action, which attempts to determine whether a defendant’s conduct was unreasonable and caused harm to the plaintiff, can be expressed as four elements, which are bolded in the next sentence. For a plaintiff to win a negligence claim, the defendant must have **breached** their **duty** of due care, thus **causing** the plaintiff’s **injuries**. The injuries must also be of the kind that tort recognizes, and there are some limitations on the plaintiff’s behavior that vary somewhat by jurisdiction and that you will learn about later in your course. Note that this standard is applied to the defendant’s conduct in determining their potential liability for negligence. However, it is also applied to the plaintiff’s conduct; in an earlier era of tort law, if the plaintiff’s conduct was unreasonable (or “contributorily negligent”), the plaintiff’s tort lawsuit would fail. In the past forty years, legal reforms changed this default. Now only a handful of states bar recovery in cases involving “contributory negligence”, that is, cases in which the plaintiff’s conduct contributed to their injuries. All the other states have adopted a “comparative fault” rule that considers the reasonableness of both the defendant’s and plaintiff’s actions and may offset liability and damages accordingly.

Summed up, the standard elements of negligence are: **duty, breach, causation, and damages**. In some jurisdictions (and casebooks, outlines and other learning materials you may encounter), causation is

broken into two prongs: causation in fact (sometimes referred to as “but-for causation” due to the most common test applied) and legal causation (commonly called “proximate cause”). This is why you will sometimes see the test for negligence listing five rather than four elements. When you cover negligence later in your course, you will devote multiple weeks to it, so don’t worry about the detailed aspects of these elements for now. Instead, keep aiming to develop a high-level view that allows you to understand the distinctions between the regimes in tort law and to look for what differentiates negligence (fault-based liability), strict liability (no-fault liability) and the intentional torts (intent-based liability).

Questions for the Readings and Areas of Focus

As you read the first three cases, please keep the following questions in mind:

- Who or what, if anyone or anything, was at fault?
- What could have—or should have—been done to prevent the harm, if anything? And by whom?
- In what ways is negligence law capable of change over time?
- Who is “the reasonable person”?

Davison et Ux v. Snohomish County, Supreme Court of Washington (1928) (149 Wash. 109)

Plaintiffs [Edwin F. Davison and wife] instituted this action against Snohomish county as defendant, seeking to recover damages alleged to have been suffered by them as the result of the negligence of defendant in the construction and maintenance of the elevated approach to a bridge known as the Bascule bridge across Ebey Slough. In the southwesterly approach to this bridge there is a right angle turn towards the south just *110 easterly of the slough, and at this point the causeway or approach to the bridge is at quite an elevation above the ground level. The bridge itself is approximately 18 feet wide; the approach leading to the bridge proper, at the curve just to the east of the bridge, increases in width to a maximum of 30.9 feet, narrowing again to 18 feet at the end of the turn.

At about 8 o’clock in the evening of November 11, 1926, plaintiffs were driving their Ford automobile toward the city of Snohomish, and proceeded to cross the bridge from west to east at a low rate of speed. Plaintiff Edwin F. Davison was driving, and, as the car rounded the curve to the east of the slough, he lost control, the car skidded, struck the railing on the east or outer edge of the approach just around the curve, broke through the railing, and, with plaintiffs, fell to the ground. Both plaintiffs suffered severe and painful injuries, and the automobile was wrecked; for all of which damage plaintiffs prayed for judgment in a large amount.

Defendant answered plaintiffs’ complaint, denying all the allegations of negligence on its part and affirmatively pleading contributory negligence on the part of plaintiffs. The action came on regularly for trial, and resulted in a verdict in plaintiffs’ favor in the sum of \$2,500. Defendant seasonably moved for judgment in its favor notwithstanding the verdict, or, in the alternative, for a new trial. Both of these motions were denied by the trial court, which thereupon entered judgment upon the verdict, from which

judgment defendant appeals. There is no dispute as to the reasonableness of the amount of the verdict, if appellant is liable at all; the sole question raised being the liability of the county for any damages whatsoever.

Respondents allege that appellant was negligent in *111 the construction and maintenance of the approach to the bridge, in that, at the time of the accident, the railing through which respondents' car broke was insufficient to act as a guard; that the posts which supported the same were decayed; that the floor or deck of the approach was so constructed as to slope out and down from the center of the curve to the outer edge, and that appellant, prior to the accident, had been repairing a road near the west approach of the bridge and in doing this work hauled over the bridge from the east a considerable quantity of dirt, a portion of which was scattered on and over the approach; that on November 11, 1926, considerable rain fell, and that, as a result, the deck of the approach, being covered with wet dirt, became very slippery, and, coupled with the other conditions alleged, constituted a menace to motor vehicle traffic.

Respondents urge that the combined effect of the different matters of which they complain produced a dangerous situation, and that the suffering of such a condition to exist constituted negligence on the part of appellant and renders appellant liable for the damages suffered by respondents. Appellant contends that respondents failed to prove negligence on the part of appellant, and that its motion for judgment notwithstanding the verdict should have been granted. [***]

It is undoubtedly the law that it is the duty of a municipality to keep its bridges in a reasonably safe condition for travel. [c] On the other hand, a municipality is not an insurer of the safety of everyone who uses its thoroughfares; nor is it required to *112 keep the same in such a condition that accidents cannot possibly happen upon them. As was stated by this court in *Grass v. City of Seattle*, 100 Wash. 542, discussing an accident to a pedestrian which it was claimed was caused by a drop in a sidewalk ranging from 2 1/2 inches at one side of the walk to nothing at the other side:

‘Manifestly, it seems to us, a city cannot be held negligent for suffering to remain in a sidewalk a defect so inconsequential as this one was shown to be. A city is not an insurer of the personal safety of every one who uses its public walks. It owes no duty to keep them in such repair that accidents cannot possibly happen upon them. Its duty in this respect is done when it keeps them reasonably safe for use-safe for those who use them in the exercise of ordinary care-and we cannot but conclude that this one was thus reasonably safe.’

Respondents admitted that they were thoroughly familiar with the bridge and its approaches, having driven over the same many times prior to the day of the accident, and they consequently were fully advised as to the existence and location of the curve in the approach, the width of the bridge, and the approaches and the different grades therein.

As respondents rely upon three several elements, each of which they claim resulted from the negligence of appellant, all three uniting to render the bridge unsafe and to cause the accident which is the basis of this action, it is necessary to analyze these elements of alleged negligence: First, the insufficiency of the railing or guard to prevent respondents' automobile from skidding off the approach; second, the fact that the deck of the approach, at the curve, sloped downward toward the outer edge, which had a tendency to cause the automobile to slide in that direction; and, third, the fact that dirt was scattered

over the deck *113 of the approach, which, being wet by the rain, caused the deck to be more slippery than it would have been had no dirt been scattered over it.

The use of the automobile as a means of transportation of passengers and freight has, during recent years, caused certain changes in the law governing the liability of municipalities in respect to the protection of their roads by railings or guards. A few years ago, when people traveled either on foot or by horse-drawn vehicles, a guard rail could, to a considerable extent, actually prevent pedestrians or animals drawing vehicles from accidentally leaving the roadbed, but, as a practical proposition, municipalities cannot be required to protect long stretches of roadway with railings or guards capable of preventing an automobile, moving at a rapid rate, from leaving the road if the car be in any way deflected from the roadway proper and propelled against the railing. As was said by this court in the case of *Leber v. King County*, 69 Wash. 134:

‘Roads must be built and traveled, and to hold that the public cannot open their highways until they are prepared to fence their roads with barriers strong enough to hold a team and wagon when coming in violent contact with them, the condition being the ordinary condition of the country, would be to put a burden upon the public that it could not bear. It would prohibit the building of new roads and tend to the financial ruin of the counties undertaking to maintain the old ones.’

This principle applies with special force to elevated causeways constructed of wood, such as the approach from which respondents’ automobile fell, as upon such a structure the railing can be anchored or secured only to the deck of the causeway. Upon the ground, in situations of special danger, strength can be given to a guard or railing by driving posts into the earth, and *114 a guard of any desired strength can be constructed in that manner. A concrete viaduct can be constructed with side walls of considerable resisting power; but the same degree of protection cannot be expected from a guard or railing along the side of an elevated frame causeway or viaduct. Respondents introduced some testimony to that effect that the posts which supported the railing were, to some extent, rotted. We have carefully considered this testimony, and, for the purposes of this opinion, assume that it was true; but we still do not think that it was sufficient to take the case to the jury upon the question of appellant’s negligence in connection with the condition of the railing at the time of the accident.

In regard to the second element of alleged negligence urged by respondents, the fact that, at the curve in the approach, the deck sloped slightly downward towards its outer edge, we are of the opinion that, in view of the fact that the slope was so slight as not to be noticeable to the eye, amounting to no more than a small fraction over an inch to 18 feet horizontal measurement across the deck, or from 2 3/4 inches to 1 1/8 inches to the entire width of the deck, it is our opinion that the maintenance of the approach in this condition did not constitute such negligence on the part of appellant as would render appellant liable to respondents in this action. The Supreme Court of Michigan, in the case of *Perkins v. Delaware Township*, 113 Mich. 377, held, as matter of law, that the maintenance of a bridge, 16 feet wide, which had no railings at all, one inch lower on one side than the other, was not negligence on the part of the township. While the facts of the Michigan case differ considerably from the situation now before us, the opinion is *115 of value in aiding us in the determination of the case at bar.

Referring to the third element of negligence relied upon by respondents, the fact that some dirt was scattered over the deck of the approach, and that due to the fact that considerable rain had fallen and was still falling at the time of the accident, the wet dirt caused the deck to be unusually slippery, we

are unable to find any testimony in the record which would justify the submission of this element of alleged negligence to the jury. Appellant would not be liable because of any ordinary accumulation of dirt or similar matter upon the approach, unless a dangerous condition were permitted to exist for such a period of time as would imply, in law, notice to appellant of the fact that its roadway was unsafe, and it should further appear that appellant had been negligent in not remedying the condition within a reasonable time. Respondents contend in this case that the dirt upon the roadway had been scattered by appellant's employees within a very short time prior to the accident. Giving the testimony upon this point the construction most favorable to respondents' contention, we feel compelled to hold that, as matter of law, there was no testimony sufficient to go to the jury upon this alleged element of appellant's negligence.

[***] Respondents rely upon the case of *Beach v. City of Seattle*, 85 Wash. 379, in which this court upheld a verdict against the municipality, based upon its negligence in leaving unguarded, poorly lighted, and without danger signals, a blind street end at the edge of a gulch. Examination of the opinion in this case indicates that the decision was based largely upon the failure of the city to place a red light or other danger signal at the street end, or to place lights in the vicinity which would disclose the dangerous situation. The city had also neglected to construct any barrier whatsoever which might serve as a visible warning of danger, as well as an obstruction. The physical facts which resulted in injury to the plaintiff in this action constituted almost an invitation to the driver of an automobile to continue along the street which was *117 broken by the deep gulch; there being nothing to suggest danger. [***]

The judgment is reversed, with directions to dismiss the action.

Note 1. What is the holding in this case? In layperson's terms, who "wins" and what do they win? In legal terms, why is that significant?

Note 2. What does it tell you if someone is a petitioner versus a respondent? (Or an appellant versus an appellee?)

Note 3. On what does the court base its reasoning, in your view? Is it focused primarily on the capacity—or incapacity—of engineering to prevent accidents like the one at issue? Or does it emphasize policy reasons? Does it focus on the plaintiff's conduct? Does it follow precedential authority in a way that disposes of the case, that is, compels the outcome?

Note 4. This case refers to "Ebey Slough," in Washington state, an area named for a white settler in the region whose relationship to the indigenous people of the Tulalip tribe was sufficiently contested that they made a bid to change the name in 2012. Ultimately the proposed name change failed and Ebey Slough remains on the map as such. As we read older cases, however, it's a good idea to be attentive to the way meanings change over time with revisions of the narratives of our nation's history and shifts in cultural awareness. For more, see: <https://www.heraldnet.com/news/should-ebey-slough-be-renamed-some-say-yes/>

Check Your Understanding (1-2)

Question 1. True or false: The court in *Davison* believed it did not have the authority to decide whether a municipality could be liable for negligent maintenance of bridges.

An interactive H5P element has been excluded from this version of the text. You can view it online here: <https://saidtorts2d.lawbooks.cali.org/?p=26#h5p-2>

Question 2. *Davison* cites earlier case law approvingly, including this dictum it offers to support its reasoning:

‘Roads must be built and traveled, and to hold that the public cannot open their highways until they are prepared to fence their roads with barriers strong enough to hold a team and wagon when coming in violent contact with them, the condition being the ordinary condition of the country, would be to put a burden upon the public that it could not bear. It would prohibit the building of new roads and tend to the financial ruin of the counties undertaking to maintain the old ones.’

Which of tort law’s primary purposes does this language most serve (or most seem to support)?

An interactive H5P element has been excluded from this version of the text. You can view it online here: <https://saidtorts2d.lawbooks.cali.org/?p=26#h5p-3>.

Bartlett v. Northern Pac. Ry. Co. & City of Tacoma, Supreme Court of Washington (1968) (74 Wash.2d 881) (Rehearing Denied Jan. 10. 1969)

The trial court in granting summary judgment of dismissal of the plaintiff’s action against the city of Tacoma and the Northern Pacific Railway Company, commented, ‘Maybe the supreme court will think differently.’ It does!

The end result may be the same at the conclusion of a jury trial, for a jury may reach the same conclusion as the trial court: That neither defendant failed in any duty owed to the plaintiff which could have prevented the injuries which he sustained. Nevertheless, we are satisfied that there are issues of fact which should be decided by a jury.

The plaintiff had driven his automobile up an inclined roadway where it makes a 90° left turn to cross a bridge over the Northern Pacific Railway tracks at a height *882 of some 35 feet above the ground. Unknown to the plaintiff, the surface of the roadway at the place where this turn occurs was slippery (there were statements that it was icy), and instead of his car making the turn, it continued straight ahead over a wooden curb, across a 6-foot sidewalk and through a guardrail, plunging to the ground below.

The plaintiff contends that the defendants knew that, at the temperatures then existing, the roadway at this point might be icy, and that no adequate warning of the potentially dangerous situation was given. The defendants² respond that plaintiff was familiar with the roadway and that a posted speed of 10 miles per hour was ample notice that more than ordinary care was required. (The defendants contend that had plaintiff obeyed that speed limit his car would not have gone over the curb, across the sidewalk and through the guardrail.)

We said in *Barton v. King County*, 18 Wash.2d 573, 576, 139 P.2d 1019, 1021, after reviewing a number of our cases:

The gist of the decisions in these cases *** is that the municipality *may* be chargeable with negligence for failure to maintain warning signs or barriers *if the situation along the highway is inherently dangerous or of such character as to mislead a traveler exercising reasonable care.*

We express no view as to the merits of the present controversy; we are simply saying: (1) that a jury could find the situation at the locus in quo was inherently dangerous, or of such a character as to have misled a traveler exercising reasonable care; and (2) if the jury should so find, then the adequacy of the warnings given and of the barriers (curbs and guardrails) maintained would likewise be a jury question and not an issue to be determined on summary judgment.

The plaintiff urges that the posted speed of 10 miles per hour gave no notice of slippery or icy conditions; he urges further that instead of a 10 or 12-inch curb, as on the rest *883 of the incline, constant hitting of the curb where his car ‘climbed’ it had ‘chewed’ it down to an effective height of only 3 or 4 inches; and that his car, at its speed of 10 miles an hour, would not have gone over an adequate curb.

The plaintiff contends that a car traveling 10 miles an hour or less can be successfully halted by relatively low-cost barriers, and that the history of similar accidents at this particular point indicated a need for more substantial barriers. The defendants respond that *Davison v. Snohomish County*, 149 Wash. 109, 270 P. 422 (1928), held that a municipality is under no duty to erect a guardrail of sufficient strength to keep an automobile from crashing through.

The precise holding in that case was that a municipality is under no duty to erect barriers sufficient to prevent automobiles traveling at a high rate of speed from crashing through. Our disposition of the present case is not intended to overrule that holding. It is obvious that the erection of barriers sufficient to prevent a speeding vehicle from crashing through could result in injuries as serious as those that would be suffered if the vehicle were to crash through a weaker barrier and collide with whatever lay

² The city and the railway company raise no question as to their joint liability, if there is any liability.

beyond. Such would not be the case where a barrier is erected to stop slow-moving vehicles from plunging off a bridge 35 feet above the ground.

The reasoning in *Davison* [c] was based on the impracticality as a matter of engineering and on prohibitive costs. We do not consider the ideas of the court, expressed 40 years ago, as necessarily authoritative on the engineering and financial phases of the same problem today. We are satisfied that the parties should have the opportunity of presenting their evidence as to the practicality (cost wise or otherwise) of guardrails or barriers on dangerous or misleading roadways to stop slow-moving vehicles.

We would in no way derogate from the summary judgment as a proper and valuable instrument for preventing useless trials; but it should not be used, as in the present case, where a real doubt exists as to decisive factual issues.

*884 The summary judgment appealed from is set aside with directions to proceed as though it had been denied.

Note 1. Revisit your statement of the holding in *Davison*. What do you notice about how *Bartlett* frames that earlier case?

Note 2. What is the holding in this case? Who prevails, and what benefit do they receive as a result?

Note 3. To what extent is the plaintiff's behavior or knowledge relevant in *Davison* and *Bartlett*? What accounts for that, in your view?

In the following opportunity to assess your own understanding, be aware that you are gaining an introduction to the elements of negligence law. Reading the questions and answers will help you deepen your own understanding as well as confirming what you have already understood. The questions are designed to *teach* you, in other words, in addition to reinforcing what you have learned.

Reflect On Your Understanding – Essay: *Bartlett v. Northern Pac. Ry. Co. & City of Tacoma*

Essay: Identify two ways in which *Bartlett* distinguishes its ruling from *Davison* and identify reasons it supplies for doing so.

An interactive H5P element has been excluded from this version of the text. You can view it online here: <https://saidtorts2d.lawbooks.cali.org/?p=26#h5p-4>

Hypothetical: Introducing Negligence and the Reasonable Person Standard

In law school, when you are instructed in “the law” (or “the black letter law”), you are usually learning to read statutes or distilling rules from the common law. But in legal practice, for litigators at least, the black letter law is often represented by jury instructions.

Jury “instructions” are the words read to a jury prior to their deliberation. In contemporary trials, such instructions may sometimes also be provided in print or on a screen so that juries can refer back to them when deliberating. The instructions are also sometimes referred to as the “charge,” as in “charging” or “instructing” the jury with the proper law to apply. These instructions include standard messages about the rules of evidence that are the same from case to case, as well as more precise statements of the law tailored to the facts of the case.

Traditionally, jury instructions have not frequently been taught in law school or featured centrally in legal casebooks. This may be partly due to the fact that, at least traditionally in the 20th century, many law professors had no practice experience. In addition, there has been a growing consensus that trials are less and less common (and thus less important). Yet jury instructions continue to play an important role in the contemporary legal world. Trial lawyers tackling new litigation often start by looking at the existing jury instructions in the relevant area of law so as to understand how they will need to frame the theory of the case. A given jurisdiction may maintain and update a set of “model” or “pattern jury instructions” which act as templates that the parties can adapt. The substance of these instructions is often hotly contested since many lawyers believe that the way the law is framed and articulated for the jury can play a key part in persuading the jury. (Usually, a case goes to full trial with a jury only if a significant part of the dispute is riding on some factual aspect. Otherwise, a court can resolve issues as a matter of law and a jury may never be needed.) Even in cases that never go to trial, however, the jury instructions provide guidelines for how both sides will shape their arguments and may play a role in forcing settlement, too.

In any event, when considering the substantive law on a given topic, if you inquire into the relevant jury instruction you are likely to be thinking like a litigator. The next hypothetical revisits negligence and asks you to apply a jury instruction to a fact pattern.

Building-Crashing Driver Hypothetical #1: A driver crashed into a building. This accident caused damage to the building property, including breaking the glass door and merchandise inside a bike shop on the premises.

The bike shop owner was inside, and he sustained injuries because of the accident. The bike shop owner asks you, a practicing attorney, whether he can sue the driver. The facts are deliberately simplified at this point, and you don't yet have the elements of various causes of action, but work from your common sense and what you know so far including your present understanding of the elements of negligence: duty, breach, causation and harm.

Step 1. What do you want to know? What questions would you ask?

Step 2. Now assume that this dispute proceeded to a jury trial and that the judge would instruct the jury to determine negligence using the following standard:

Negligence is the doing of something which a reasonably prudent person would not do, or the failure to do something which a reasonably prudent person would do, under circumstances similar to those shown by the evidence. It is the failure to use ordinary or reasonable care.

Ordinary or reasonable care is that care which persons of ordinary prudence would use in order to avoid injury to themselves or others under circumstances similar to those shown by the evidence.

What would you want to know if you were a jury tasked with this determination?

One significant subset of tort law concerns negligence, or accidental or careless wrongdoing that results in harm. The test for determining negligence is whether or not the parties' conduct was "reasonable" under the circumstances. This is known as the "**reasonable person**" standard. Tort law does not anticipate that actors will behave perfectly, or even expect that they will try to do so. The theory is that it would be costly and unfair to require that people move through the world never causing any harm; if people were liable for every possible harm they might cause, they might stop doing many things that are socially valuable but involve some amount of risk. Instead, tort law imposes a reasonableness standard. The outcome of this determination depends on the judge or jury's best retrospective guess of how a "reasonable person" would have behaved under the same circumstances.

Note that this standard is applied to the defendant's conduct in determining their potential liability for negligence. However, it is also applied to the plaintiff's conduct; in an earlier era of tort law, if the plaintiff's conduct was unreasonable (or "**contributorily negligent**"), the plaintiff's tort lawsuit would fail. In the past forty years, legal reforms changed this default. Now only a handful of states bar recovery in cases in which the plaintiff's conduct contributed to their injuries. All the other states have adopted a "comparative fault" rule that considers the reasonableness of both the defendant's and plaintiff's actions and may offset liability and damages accordingly.

With that introduction to the reasonable person standard, let us turn to a nineteenth-century negligence case to explore its application in early American tort law.

As you read the court's opinion in that appeal, consider the core question: what would a reasonable person have done under these circumstances? What would a reasonable town have done with respect to its causeway?

Fox v. Town of Glastenbury, Supreme Court of Errors of Connecticut (1860) (29 Conn. 204)

[***] An inlet from Connecticut river, called the cove, runs up into the mainland in the town of Glastenbury. [***] [A] highway had been laid through this cove to the Wethersfield ferry, and a causeway constructed thereon for the accommodation of the public travel. [***] The water in the cove, along the sides of the causeway, was ordinarily about one foot deep, but in times of freshet it frequently rose so high as to submerge the causeway, and render its passage perilous and sometimes impossible. [***] The deceased and her companion, Mrs. Clarinda Fox, had for several years resided about half a mile from the east end of the causeway, and one of them, at least, had repeatedly crossed it.

About three o'clock in the afternoon of the 6th of August, 1856, having procured a horse and wagon, they started to go over the causeway, from the main land to the ferry. There was a freshet in the river, and the water had in consequence risen in the cove so as to cover the causeway, was rising rapidly, and there was a strong wind.

The deceased and her companion stopped in front of the house of Mrs. French, a short distance from the causeway, but in full view of it, and there observed that the water was running over the causeway, and that the wind was high. The deceased inquired of Mrs. French whether people crossed there that day, to which Mrs. French replied that they had, but that she had seen no one pass that way that afternoon, and that she had not before noticed that the water was over the road. The deceased then inquired of Mrs. French if she would dare to cross. Mrs. French replied that she would be afraid, unless she had a very gentle horse; and the deceased remarked that their horse was perfectly gentle. We deem this conversation of some importance, because it shows that, while these ladies were encouraged to go on, by the information that others had passed before them, and by the fact that they had a gentle horse, they were not betrayed into their perilous undertaking, either by the apparent safety of the road, or by their own inattention to its condition, until it was too late to avoid it altogether; and that when they were entirely beyond the reach of danger, and could, with but little inconvenience, have avoided it, they deliberately determined to encounter and risk whatever of it might beset their way.

As they approached the causeway, the cove and the condition of the water in it could not have escaped their notice. They saw [***] that the causeway was entirely submerged, that a swift and strong current of turbid water *207 was passing over it, that there was no rail or visible object of any kind, above the surface of the water, on the sides of the causeway, by which they could be protected or guided in their course, and the depth of the water it was obviously impossible for them, before they went into it, with any degree of accuracy, to calculate or determine. East of the bridge, the water rose to the hubs of the fore wheels of their wagon, but they reached the bridge in safety. The bridge was raised about two feet and a half above the level of the causeway.

On the bridge they stopped, noticed and remarked upon the height of the water and the rapidity of its current, and felt some degree of alarm, but concluded to proceed. As they drove from the bridge into

the water on the west side of it, they began to apprehend the extent of their danger, and became frightened; the horse stopped; they urged him forward with the whip, and becoming more frightened they probably attempted to turn around, and went off the causeway, nearly at a right angle with it, into the deep water on the north side. These facts seem to us fully proved by the evidence. And we think that in driving upon the causeway at all, even easterly of the bridge, submerged as they saw it was, and with nothing visible above the surface of the water to indicate its true location, these ladies disregarded the dictates of ordinary prudence and discretion.

And surely, when upon the bridge, in full view of the scene before them, and aware, as they must have been, of the accumulated and increasing dangers in their path, and ... with the knowledge which they then possessed of the impossibility of seeing the road, because of the turbid condition and ruffled surface of the water, and the rapidity of its current, they determined to proceed, and drove into the stream, their conduct was far below the standard of ordinary prudence. [***]

The bridge was twenty-four feet long, and fourteen feet wide between the railings. On this bridge they were safe; and if they could not, unaided, have turned around and retraced their steps, they could, and should have remained where they *208 were, until relieved from their unpleasant but not perilous situation. And again, when, after they had entered the water west of the bridge, their horse, true to the instincts of his noble nature, faltered, and stood still, they should have heeded his kindly admonition, and there waited for assistance and deliverance, instead of forcing the animal forward to his fate. The boat, by means of which one of them was rescued, with two boys in it, was sailing close at hand; a wagon, with two men in it, was approaching the causeway from the west; and the residence of Mrs. French, with whom they had just been conversing, was within the reach of their voices. Their outcry would have brought almost immediate relief.

In view of all the facts and circumstances, [***] we feel constrained to say, that the attempt of these ladies to pass over this causeway [***] was an act of rashness, which, upon the well settled principles of law applicable in cases of this character, bars all claims in their behalf for damages from the town. We think no person of ordinary discretion in their circumstances, and exercising ordinary prudence and discretion, would have made such attempt.

We are not unmindful of the fact urged upon our attention by the plaintiff's counsel, that these travelers were females. And in that fact, and in the timidity, inexperience, and want of skill which it implies, we can find an explanation of their injudicious and fatal attempt to turn around in the water, but no reason or excuse for the recklessness of their conduct in driving into it. [***] The inquiry whether, in the particular case, the party conducted with ordinary care or prudence, always involves the consideration of the difficulties and obstacles to be overcome, the party's knowledge of their existence, and his means and power to overcome them. And if men of ordinary prudence and discretion would regard the ability of the party inadequate *209 for the purpose, without hazard or danger, the risk should not be assumed. [***]

In order to entitle the plaintiff to a verdict, he was bound to show, affirmatively, not only the culpable negligence of the town, but also that the decedent herself conducted with ordinary prudence and discretion. [***] The application of this settled rule of law we suppose the jury, from inadvertence, or some other cause, must have failed to make, and finding the negligence of the town, must have decided to charge it with all the consequences of the accident, regardless of the co-operating carelessness of

the decedent; which, in our judgment, was distinctly shown by the evidence, and completely established the defense. We think a new trial should be granted.

Note 1. Do you agree with the court’s determination on these facts, that “no person of ordinary discretion in their circumstances, and exercising ordinary prudence and discretion, would have made such attempt”? How do you explain your reasoning? Why do you think the court relays the conversation the travelers had with Mrs. French, who seemed to provide evidence that the road might be passable? Most of us have not faced this exact circumstance and many of us have not even faced analogous circumstances. Tort law often requires that factfinders use their imagination and empathy to recreate the scene of the accident and evaluate what was “reasonable” under those circumstances. Might the purposes of Mrs. Fox’s trip matter to the analysis (recalling that she and her companion were described as trying to reach the ferry)?

Note 2. In a way, the reasonableness standard permits tort law to “crowdsource” what the right thing to do is, in any given situation. However, traditionally this crowdsourcing reflected the dominant viewpoint of the “reasonable man.” What would *he* do under the circumstances, whether considering the facts in terms of the defendant’s conduct or the plaintiff’s conduct and injury. For instance, what would the reasonable man do in taking precautions on a hog farm or when battling a grease fire? For more discussion of the role of gender and reasonableness, *see* Margo Schlanger, *Gender Matters: Teaching a Reasonable Woman Standard in Personal Injury Law*, 45 St. Louis U. L. J. 769 (2001), Leslie Bender, *A Lawyer’s Primer on Feminist Theory and Tort*, 38 *J. Legal Educ.* 3, 22 (1998)). Can you think of specific circumstances in which the “reasonable man” standard could or should differ from the “reasonable woman” standard? Is *Fox v. Glastenbury* such a case? Put another way, are there circumstances in which using a “reasonable person” standard might not be appropriate? How would you characterize the judicial description of the plaintiff’s conduct? Note the awkward phrase negating mindfulness: “We are not unmindful of the fact urged upon our attention by the plaintiff’s counsel, that these travelers were females.” Does the court give that fact legal significance or not? Is the reasonable person standard sexist? Why or why not?

Note 3. The opinion is focused on the appeal’s narrow question of whether Mrs. Fox was negligent. However, an applicable statute required that a raised road like this one be “adequately protected by a fence or railing on its sides” and the court actually acknowledged that “a majority of us are of opinion that the town [was] culpably negligent in regard to such protection.” Thus the court would not have overturned Mr. Fox’s favorable verdict had Mrs. Fox not been found negligent herself. If asked to do so, how would you analyze the reasonableness (or culpability) of the town on these facts?

Note 4. *Davison*, *Bartlett* and *Fox* all involve cases brought against municipalities for injuries that can be traced to the failure of railings or guardrails. Can you think of ways to frame the three cases so as to analogize and distinguish them?

Note 5. Employment Harassment and Discrimination. Over time, courts increasingly began to refer to the reasonable *person* rather than the reasonable *man*. Yet that did not go far enough in at least one area of law.

The tort law of workplace harassment—which consists of a mix of federal and state laws—remains difficult for plaintiffs to use in fighting injuries suffered as a result of toxic employment environments. However, winning sexual harassment cases became somewhat more feasible once courts stopped

downplaying the threats (and unwanted invitations) women experienced at work and began to take their claims more seriously. Doing so, however, arguably required that courts shift from a reasonable person standard to a reasonable *woman* standard.

In *Ellison v. Brady*, 924 F.2d 872, 878-9 (9th Cir. 1991), the Ninth Circuit adopted the perspective of the “reasonable victim”:

If we only examined whether a reasonable person would engage in allegedly harassing conduct, we would run the risk of reinforcing the prevailing level of discrimination. Harassers could continue to harass merely because a particular discriminatory practice was common, and victims of harassment would have no remedy.

924 F.2d 872, 878-9.

In other words, while this standard might seem reasonable from the harasser’s perspective—given the prevalence of sexist behavior in the workplace—applying it would unfairly prevent victims from recovering. *Ellison* thus demonstrates the court’s awareness of the risks of “crowdsourcing” reasonableness, namely that the so-called “reasonable person” might behave in ways that are harmful yet common. Tort law might perpetuate structural discrimination if it conducted its reasonableness inquiry in its ordinary manner in such cases since it might be argued that the prevalence of harmful conduct was proof of its reasonableness. *Ellison* opted for a shift from the harasser’s conduct to the impact on the plaintiff and applied a “reasonable victim’s” perspective to correct what would otherwise be a failure of tort law:

We therefore prefer to analyze harassment from the victim’s perspective. A complete understanding of the victim’s view requires, among other things, an analysis of the different perspectives of men and women. Conduct that many men consider unobjectionable may offend many women. *See, e.g., Lipsett v. University of Puerto Rico*, 864 F.2d 881, 898 (1st Cir. 1988) (“A male supervisor might believe, for example, that it is legitimate for him to tell a female subordinate that she has a ‘great figure’ or ‘nice legs.’ The female subordinate, however, may find such comments offensive”); *Yates*, 819 F.2d at 637, n. 2 (“men and women are vulnerable in different ways and offended by different behavior”). We realize that there is a broad range of viewpoints among women as a group, but we believe that many women share common concerns which men do not necessarily share. 924 F.2d 872, 878-9

There is much that can be said about *Ellison v. Brady*’s adoption of the reasonable victim perspective. First, it feels outdated. The court seemed to find it necessary to explain something that may seem pretty obvious in 2022: in the workplace, telling a colleague or subordinate that they have nice body parts is inappropriate, especially when doing so repeatedly or in the context of a hierarchical or supervisory relationship. Second, it may seem odd to consider the “reasonableness” of the victim’s response to an aggressive and inappropriate (gender-based) power play at work. Is there such a thing as an “unreasonable” victim in certain instances? Third, the court grounds its relief not in the powerful stance of autonomy but the vulnerable one of victimhood.

The court proceeds to explain that women are disproportionately more likely to be the victims of sexual assault and thus “[w]omen who are victims of mild forms of sexual harassment may understandably worry whether a harasser’s conduct is merely a prelude to violent sexual assault. Men, who are rarely

victims of sexual assault, may view sexual conduct in a vacuum without a full appreciation of the social setting or the underlying threat of violence that a woman may perceive.” Per *Ellison*, women have a “stronger incentive to be concerned with sexual behavior.” *Id.* By framing the harm in terms of fear or as a prelude to sexual violence, the court seems to ignore that these comments are demeaning and discriminatory in their own right. Harassing statements like these are acts of power reminding women to remain in their place.

Are there ways to expand the judicial imagination towards greater empathy and understanding of sociological difference without casting the plaintiff in terms of a victim? Can power structures be acknowledged and made transparent using different rhetoric, or in a way that emphasizes different aspects of a legal rule? For instance, a woman’s autonomy interest in being free from unwanted sexual advances could justify liability on facts like these even if a woman did not fear becoming a victim of sexual violence. How might “reasonableness” analysis look if so?

In addition, in departing from the “reasonable person” standard in favor of the “reasonable woman” standard, *Ellison* relies on the justification that the reasonable person might ignore or tolerate conduct that was intolerable to the reasonable woman, which would thus “run the risk of reinforcing the prevailing level of discrimination.” In a sense, this is the risk of “crowdsourcing” reasonableness. By considering reasonableness as an objective standard most of the time—which means generalizing it to some level of conduct rather than particularizing it to the party before the court—we aim to capture community mores and values.

When might departures from this practice be justified? Should the standard be particularized in gender discrimination cases only? What about racial discrimination cases? If labor and employment disputes in tort law fall most heavily on those with lower socioeconomic status, or on particular ethnicities, should those be taken into account? What role should demographics play in setting the standard for reasonableness?

Note 6. Though it represented a substantive win for feminism as well as the plaintiff at bar, *Ellison* is not the first or the last time the judiciary essentialized gender, even if aiming at a progressive outcome. By using the “reasonable woman” standard, *Ellison* may have inadvertently made it more difficult for people whose identity does not conform with traditional gender categories and who might be facing similar patterns of discrimination. As gender identity becomes more widely acknowledged as non-binary or fluid, what responsibility do legislators, lawyers and judges have, if any, to take account of this expanding awareness of the social constructedness of identity?

Building-Crashing Driver Hypothetical #2: Recall the facts of the earlier hypothetical in which a driver crashed into a building, causing property damage and physical injuries. You were asked to consider the reasonable person standard and what you might need to know to determine whether the bike shop owner could bring an action against the driver.

Now you are told that the driver was epileptic and had been suddenly rendered unconscious at the wheel mere seconds before he crashed into the building.

Once again, the bike shop owner asks you, a practicing attorney, whether he can sue the driver. Recall that the elements of negligence are duty, breach, causation and harm. What would you now want to know in order to determine whether an action might be available against the driver?

Chapter 3. Introduction to Strict Liability

Strict liability is a regime in tort law in which neither fault nor intent is relevant to liability: the actions that caused injury were of a particular kind so dangerous, or for other reasons deemed so risky, that courts or legislators have decided to classify the conduct as a strict liability activity. A plaintiff merely needs to prove that the defendant **acted** in such a way that **caused** the plaintiff's **injuries**: the elements are action, causation, and harm. In theory then, this looks simple; in practice, it can be more complex, either because a factual question exists as to whether the action properly falls within a category of behavior deemed strict liability or because the question is one “of first impression”—never decided by this court before—and a court must newly decide how to categorize this new form of behavior or risk.

Often when faced with such a question, courts and legislatures look to existing categories of actions subject to strict liability. For example, ownership of wild animals is strict liability (and in many jurisdictions, even dog bites are treated under strict liability). Uses of dynamite and other forms of “ultrahazardous activity” fall under strict liability in most instances, and in some jurisdictions, this means that firework displays are governed by strict liability. Students are sometimes surprised to learn that gun use and manufacture are *not* subject to strict liability. Finally, one kind of product liability action is generally considered under strict liability, as you'll learn if your course covers products liability later in the term. Courts may analogize the conduct in question to one of those existing categories. In evaluating whether an action should be categorized as strict liability courts may also consider the level and kind of risks the action poses versus the benefits that flow from such action (or from the use of such a product, in product liability cases). Policy determinations about the possibilities for innovation may depend on tort law's fact-sensitive capacity for balancing the benefits and risks to various different stakeholders. These policy questions become especially salient with respect to emerging technologies which often seem to carry great promise but also come with unknowns regarding how they will be integrated into society and how their risks will be fully discovered and managed.

What are your **intuitions** about the proper balance when it comes to regulating new technologies? As a **normative** question, consider whether you think driverless cars, drones or highly immersive games such as Pokémon GO *should* be subject to strict liability. **Descriptively**, numerous regulatory provisions at the state and federal level already cover some aspects of these technologies but it's worthwhile to think, in this introductory module, about what you think as a policy matter is a sound answer for tort law, and why.

Introduction to the Restatements

As courts and legislatures reflect on these issues, they often turn to an important resource called the Restatement of Law. There are four Restatements for tort law: *The Restatement Third of Torts: Liability for Physical and Emotional Harm* (2010/2012), *Apportionment of Liability* (2000), *Products Liability* (1998), and *Liability for Economic Harm* (2020). You can learn more about them here: <https://www.ali.org/publications/show/torts/> or search online for general discussions of them. They are descriptions of existing black-letter law, drafted by practitioners,

academics and judges in committees that spend years contributing to making these extensive records of the law. The Restatements predated the widespread availability of legal databases that have since made researching national law comparatively easy. Before such databases were available, it was often hard to locate and survey “court reporters,” which were expensive, heavy tomes not necessarily organized in uniform or consistent ways. The Restatements provided an efficient means of learning the contours of an area of law in many jurisdictions at once. Even in the era of databases, however, the Restatements have remained useful in their capacity to provide reliable summaries of the law along with extensive examples and comments.

The Restatements—as their name implies—are meant to restate or summarize the law, *descriptively*. In some areas of law, including torts, they grew more *prescriptive* or *normative*. Instead of expressly trying to state what the law simply “was” for instance, the drafters of the Restatement on Products Liability added to its summaries of the law their recommendations for what the law “should be, ideally.” (This distinction provides an example of why it’s helpful to learn to distinguish between descriptive and normative statements of law.) The Restatement (Third) is not yet completed so you may see courts, treatises and this casebook refer to provisions of either the Second or the Third at different points. Various controversies have arisen with respect to some of the positions taken by the drafters of the Third Restatement. Judicial opinions sometimes reflect this by stating that they will retain the rule of the Second rather than adopting the Third on a given issue. Armed with this basic background on the Restatements of law, you are now in a better position to understand the role they play in the formation of strict liability law, especially in the last case in this section, *Toms v. Calvary*, below.

Questions for the Readings

As you read the next two cases, please keep the following questions in mind:

- When is strict liability applicable?
- Why does policy dictate the imposition of strict liability in some instances, but not in others?
- What does this tell us about tort law’s deeper purposes?

A note about confusing terminology in the next case: Respondent Halsett is considered a “licensor” of laundry equipment because he allows customers of his laundromat to enter his property and use his machines. Petitioner Garcia is a “licensee.” The court makes reference to an argument that’s been omitted here for length and clarity, in which Halsett tried to argue that Garcia was a “bailee” of the defective washing machine. The court dismisses that theory, which was Halsett’s attempt to argue that the young injured boy should have borne responsibility for the operation of Halsett’s commercial washing machine.

Garcia v. Halsett, Court of Appeals of California, First App. Dis., Div. Three (1970)
(3 Cal.App.3d 319)

The plaintiffs appeal from a judgment in favor of the defendant following a jury trial. On July 19, 1962 the appellant, Arthur Garcia, an 11-year old boy, was injured in respondent's Happy Coin Launderette in San Jose. Respondent had owned the business since 1959. Launderette Sales designed the store layout and sold and installed all of the equipment. Respondent had nothing to do with the design of the store or with installation of the equipment. The facilities of the launderette included four rows of coin operated washing machines. The machines were Philco-Bendix, front-loading, commercial washers. These machines have a washing cycle, three rinse cycles, two spin cycles, and one long extraction cycle. The last of these cycles is a spin cycle lasting 4 1/2 or 5 minutes, during which the tub of the machine obtains a velocity of 370 revolutions per minute. The entire procedure lasts 30 minutes.

At the time of the accident, the machines were equipped with a circuit breaker, or reset button. The circuit breaker is a fuse, and has one purpose only: In the event of a short in the machine, or of a motor overload, which would create a heavy draw of current and consequently constitute a fire hazard, the circuit breaker will break the circuit and stop the machine completely. If the circuit breaker button is depressed while the machine is running, it will stop the machine. However, the moment that the button is released the machine will start operating again. The circuit breaker is not used to stop the machine manually. Respondent testified that the manufacturer did not intend that this button should be used to stop a machine in order to reach into the loaded machine.

The appellant, Arthur Garcia, had been instructed by his mother as to how to run the machines and had been going there to wash clothes about once a week. He had also read the posted instructions regarding the loading of the machine. The uncontradicted testimony of the appellants establishes that the accident took place in the following manner: On the date of the accident, Arthur went to the Happy Coin Launderette with his 10-year old brother to do some laundry. When he entered the launderette, he looked for available machines, and found machines 1 and 2 at the far end of the launderette. On prior occasions when he went to the launderette, he always used this same type of washing machine. He took a portion of the clothes and put them in machine No. 1, and then inserted a quarter and started the machine. He then went to machine No. 2, put in the balance of the laundry, inserted a quarter, and started the second machine. Both machines started. In accordance with the posted instructions, he put soap in each machine, and began to read a magazine.

While he was sitting there, machine No. 2, the machine which he had started second, stopped. He actually saw the machine stop. Prior to that time, the machine had been spinning. He had seen it spinning through the window in the machine. The water had all drained out and it was clean; he could see through the window in the washer. After machine No. 2 stopped, he waited until machine No. 1 stopped, three or four minutes later. He unloaded the clothes from machine No. 1. During this time machine No. 2 was stopped. He then went to machine No. 2 and began removing the clothes.

The first batch of clothes he pulled out of machine No. 2 were 'all dry, like spin dry'. When he inserted his hand into the machine the second time, the machine made a funny noise and started up fast. When the machine started up, his arm became entangled in the clothing. His arm was twisted around and he himself was twisted around until he had his back to the machine.

Respondent Halsett testified that upon hearing Arthur's screams he came out of the office at the rear of the launderette. The quickest thing he could think of to do under the circumstances was to pull the plug, *323 which is located at the back of the machine. In order to pull the plug, he had to go over the top of the machine and reach down in back. He could have depressed the reset button, but as soon as one let go of the button, the machine would start up again. When respondent returned to the launderette, after having taken Arthur home, he plugged in machine No. 2, and at that time the machine was in its fast spin cycle. Respondent also testified that he thought the washing machine in question was perfectly safe and had all the safety features that were required. However, he also testified that the machine did not have a micro switch and that they were not available at that time.

A micro switch is a sensitive, pressure-activated switch which is placed across the main electrical circuit of the machine. It serves as a safety device. When activated, by opening the door, it completely shuts off the electricity going through the machine. The purpose of the micro switch is to prevent the machine from operating when the door is opened. Respondent admitted that if such a switch had been on the machine on the date of the accident, the machine could not have started spinning when Arthur opened the door and inserted his arm.

Micro switches sell for around \$2.00. Shortly after the accident respondent obtained 12 of these micro switches and installed them himself on the machines. Experts for both appellants and respondent testified that micro switches had been on the market for a number of years. Appellants' expert witness, an experienced appliance dealer, testified that, in his opinion, the washing machine in question was defective because, first, the timing mechanism was defective, and, second, a 1958 Bendix commercial washer manufactured without a micro switch would be defective. If the machine was manufactured without a micro switch, a switch could be purchased and installed. This machine was defective because it did not have a micro switch on it. Other Philco-Bendix machines manufactured as early as 1952 had micro switches. Machines produced by other manufacturers have micro switches which serve as safety switches. Appellants' expert witness also testified, in effect, that wear and tear resulting from years of use may result in a timer becoming faulty, thus causing the machine to stop during a cycle and then start again when the machine is jarred or the door opened.

The appellants contend that the trial court committed reversible error in that it refused to give the instructions offered by appellants on (1) bailment, and (2) strict liability.

[***] There is no question raised as to the form of the instructions, only as to their applicability. The appellants' contention is without merit since the facts do not establish a bailment of the washing machine. [***] In order to constitute a bailment, possession of the article bailed must be given or delivered to the bailee. [cc] Appellants contend that appellant Arthur had at least constructive³ possession of the washing machine during the time he was using it. However, this argument is also without merit. Appellant Arthur assumed no responsibility for the safekeeping of the machine, and did not have the right to remove it or tamper with the mechanical parts of the washer. Appellant Arthur merely acquired a license to use the washing machine and was not a bailee. [c] Since respondent could have prevented appellant Arthur from using the washing machines, and respondent

³ Editor's note: "Constructive" is a term of art that indicates that the law will make an assumption, regardless of the truth. Constructive possession would mean that whether or not Arthur actually possessed the machine, he could, for legal purposes, be assumed to be a possessor. The court immediately rejects this idea but the word "constructive" will return later in the course as a way of signaling that the law is making an assumption or relying on a legal fiction for particular purposes.

impliedly gave Arthur permission to use them, Arthur merely had a license and cannot be considered a bailee of the machines.

The appellants submitted proposed jury instructions on the issue of strict liability in tort which the court refused to give. [***]

Strict liability applies to the manufacturer of chattels which cause personal injury. (*Greenman v. Yuba Power Products, Inc.*, 59 Cal.2d 57, 63 1049.) This liability *325 has been extended to retailers and distributors of chattels. (*Vandermark v. Ford Motor Co.*, 61 Cal.2d 256, 262—263.) In the recent case of *McClaflin v. Bayshore Equipment Rental Co.*, 274 A.C.A. 487, strict liability was imposed upon the lessor of a chattel. In *McClaflin*, plaintiff's decedent rented a ladder from defendant and subsequently died from injuries received when the leg of the ladder cracked, and decedent fell from it.

The precise legal relationship between the parties has not played a particularly significant role in the cases imposing strict liability. The court in *McClaflin* stated [c]: 'The *Greenman* rule, moreover, extends its protection to the injured party without reference to the role he played, or even if he played none, in the transaction wherein the defective chattel was acquired from its purveyor. He can be a retail buyer (*Greenman v. Yuba Power Products, Inc.*, supra [c]), a member of the buyer's family (*Vandermark v. Ford Motor Co.*, supra [c]), the buyer's employee (*Casetta v United States Rubber Co.* (1968), 260 Cal.App.2d 792, 795), or a 'mere bystander' totally unconnected with the chattel's purveyor except as an ultimate victim. (*Elmore v. American Motors Corp.*, supra, 70 A.00 C. 615, 618, 623—624.)'

Respondent's argument would exclude from the protected class a person who has a license to use a product but has no control over it. Appellants' position in the present case is somewhat analogous to that of the innocent bystander protected in *Elmore v. American Motors Corp.*, 70 Cal.2d 578, 75 Cal.Rptr. 652. Appellant Arthur in the present case did not have control over the washing machine, or have the opportunity to inspect it for mechanical defects other than those which would be obviously apparent. In this regard, appellant Arthur is actually in a worse position than a retail buyer or member of the buyer's family, who arguably have an opportunity to inspect a product before buying and using it. Appellant Arthur's only choice was to pick, at random, a washing machine provided by respondent for use by the public. The fact that he picked one that may have had a latent defect should not bar his recovery for injuries sustained when the machine malfunctioned.

Licensors of personal property, like the manufacturers or retailers or lessors thereof, 'are an integral part of the overall * * * marketing enterprise that should bear the cost of injuries resulting from defective products.' [cc] *326 Although respondent is not engaged in the distribution of the product, in the same manner as a manufacturer, retailer or lessor, he does provide the product to the public for use by the public, and consequently does play more than a random and accidental role in the overall marketing enterprise of the product in question. Thus, the rationale of *Greenman* and *Vandermark* applies as logically and desirably to a licensor of chattels as to the manufacturers, retailers and lessors thereof. The trial court should have instructed on the issue of strict liability.

Respondent contends that there is no evidence of a defect and thus strict liability is not applicable in this case. However, it is well settled that a defect may be established by circumstantial evidence. [cc] The facts summarized above demonstrate that there was ample evidence from which it could be concluded that the machine in question was defective.

The judgment is reversed.

Note 1. Why does the court address “the precise legal relationship between the parties”?

Note 2. Does the court hold that there was a defect with the washing machine? What do you think is the legal significance of this issue and who decides it?

Note 3. In the era in which this case was decided, there were hundreds of laundromats in greater San Francisco. This site claims that in 1966 there were nearly 500, compared with fewer than 100 in 2016: <https://hoodline.com/2017/05/trend-analysis-san-francisco-is-losing-its-laundromats>

Generally, significantly fewer single-family homes owned their own laundry machines in large cities, compared with today’s rates. If laundromats were a primary way that urban households did their laundry, a ruling on the liability for machine defects carried substantial implications. I have been unable to find data on the plaintiff, and it would be a mistake to infer very much from the surname, Garcia. However, we know that the plaintiff was a young male and the name “Garcia” suggests he may have been of color. Moreover, we know that his family depended on the laundromat and on his efforts there for the household. Do you think any of these factors were taken into account by the court? Normatively, do you think they should be in cases like this one?

Check Your Understanding (1-3)

Question 1. Which of the following statements is true of the holding in *Garcia v. Halsett*:

An interactive H5P element has been excluded from this version of the text. You can view it online here: <https://saidtorts2d.lawbooks.cali.org/?p=28#h5p-5>

Note: The following case is a classic tort law case featuring explosives that cause injury to animals, specifically mink kittens. It illustrates an important set of points about the applicability and scope of strict liability but it’s not going to garner much love from readers who are also animal lovers. In the case, you will see references to a theory of tort liability associated with the use of land, called “nuisance.” A person may be found liable for nuisance based on unreasonable or unlawful use of their property in a manner that substantially interferes with the enjoyment or use of another’s property. It can accompany a trespass or be separate from it; odors or sounds, for instance, that travel across property lines, can count. Private nuisance affects the possessor or owner of property; public nuisance affects the community as a whole. The case presents nuisance only as an alternative theory but you may still find it helpful to have that definition upfront.

Foster v. Preston Mill Co., Supreme Court of Washington (1954) (44 Wash.2d 440)

Blasting operations conducted by Preston Mill Company frightened mother mink owned by B. W. Foster, and caused the mink to kill their kittens. Foster brought this action against the company to recover damages. His second amended complaint, upon which the case was tried, sets forth a cause of action on the theory of absolute liability, and, in the alternative, a cause of action on the theory of nuisance.*441 After a trial to the court without a jury, judgment was rendered for plaintiff in the sum of \$1,953.68. The theory adopted by the court was that, after defendant received notice of the effect which its blasting operations were having upon the mink, it was absolutely liable for all damages of that nature thereafter sustained. The trial court concluded that defendant's blasting did not constitute a public nuisance, but did not expressly rule on the question of private nuisance. Plaintiff concedes, however, that, in effect, the trial court decided in defendant's favor on the question of nuisance. Defendant appeals.

Respondent's mink ranch is located in a rural area one and one-half miles east of North Bend, in King county, Washington. The ranch occupies seven and one half acres on which are located seven sheds for growing mink. The cages are of welded wire, but have wood roofs covered with composition roofing. The ranch is located about two blocks from U. S. highway No. 10, which is a main east-west thoroughfare across the state. Northern Pacific Railway Company tracks are located between the ranch and the highway, and Chicago, Milwaukee, St. Paul & Pacific Railroad Company tracks are located on the other side of the highway about fifteen hundred feet from the ranch.

The period of each year during which mink kittens are born, known as the whelping season, begins about May 1st. The kittens are born during a period of about two and one-half weeks, and are left with their mothers until they are six weeks old. During this period, the mothers are very excitable. If disturbed by noises, smoke, or dogs and cats, they run back and forth in their cages and frequently destroy their young. However, mink become accustomed to disturbances of this kind, if continued over a period of time. This explains why the mink in question were apparently not bothered, even during the whelping season, by the heavy traffic on U. S. highway No. 10, and by the noise and vibration caused by passing trains. There was testimony to the effect that mink would even become accustomed to the vibration and noise of blasting, if it were carried on in a regular and continuous manner.

*442 Appellant and several other companies have been engaged in logging in the adjacent area for more than fifty years. Early in May, 1951, appellant began the construction of a road to gain access to certain timber which it desired to cut. The road was located about two and one-quarter miles southwest of the mink ranch, and about twenty-five hundred feet above the ranch, along the side of what is known as Rattle-snake Ledge. It was necessary to use explosives to build the road. The customary types of explosives were used, and the customary methods of blasting were followed. The most powder used in one shooting was one hundred pounds, and usually the charge was limited to fifty pounds. The procedure used was to set off blasts twice a day-at noon and at the end of the work day.

Roy A. Peterson, the manager of the ranch in 1951, testified that the blasting resulted in 'a tremendous vibration, is all. Boxes would rattle on the cages.' The mother mink would then run back and forth in their cages and many of them would kill their kittens. Peterson also testified that on two occasions the blasts had broken windows. Appellant's expert, Professor Drury Augustus Pfeiffer, of the University

of Washington, testified as to tests made with a pin seismometer, using blasts as large as those used by appellant. He reported that no effect on the delicate apparatus was shown at distances comparable to those involved in this case. He said that it would be impossible to break a window at two and one-fourth miles with a hundred-pound shot, but that it could cause vibration of a lightly-supported cage. It would also be audible. Charles E. Erickson, who had charge of the road construction for appellant in 1951, testified that there was no glass breakage in the portable storage and filing shed which the company kept within a thousand feet of where the blasting was done. There were windows on the roof as well as on the sides of this shed.

Before the 1951 whelping season had far progressed, the mink mothers, according to Peterson's estimate, had killed thirty-five or forty of their kittens. He then told the manager *443 of appellant company what had happened. He did not request that the blasting be stopped. After some discussion, however, appellant's manager indicated that the shots would be made as light as possible. The amount of explosives used in a normal shot was then reduced from nineteen or twenty sticks to fourteen sticks. Officials of appellant company testified that it would have been impractical to entirely cease road-building during the several weeks required for the mink to whelp and wean their young. Such a delay would have made it necessary to run the logging operation another season, with attendant expense. It would also have disrupted the company's log production schedule and consequently the operation of its lumber mill. In this action, respondent sought and recovered judgment only for such damages as were claimed to have been sustained as a result of blasting operations conducted after appellant received notice that its activity was causing loss of mink kittens.

The primary question presented by appellant's assignments of error is whether, on these facts, the judgment against appellant is sustainable on the theory of absolute liability.

The modern doctrine of strict liability for dangerous substances and activities stems from Justice Blackburn's decision in *Rylands v. Fletcher*, 1 Exch. 265, decided in 1866 and affirmed two years later in *Fletcher v. Rylands*, L.R. 3 H.L. 330. Prosser on Torts, 449, § 59. As applied to blasting operations, the doctrine has quite uniformly been held to establish liability, irrespective of negligence, for property damage sustained as a result of casting rocks or other debris on adjoining or neighboring premises. [cc]

There is a division of judicial opinion as to whether the doctrine of absolute liability should apply where the damage *444 from blasting is caused, not by the casting of rocks and debris, but by concussion, vibration, or jarring. 92 A.L.R. 741, annotation. This court has adopted the view that the doctrine applies in such cases. In the *Patrick* case, it was held that contractors who set off an exceedingly large blast of powder, causing the earth for a considerable distance to shake violently, were liable to an adjoining owner whose well was damaged and water supply lost, without regard to their negligence in setting off the blast, although there was no physical invasion of the property. [cc]

However the authorities may be divided on the point just discussed, they appear to be agreed that strict liability should be confined to consequences which lie within the extraordinary risk whose existence calls for such responsibility. Prosser on Torts, 458, § 60; Harper, *Liability Without Fault and Proximate Cause*, 30 Mich.L.Rev. 1001, 1006; 3 Restatement of Torts, 41, § 519. This limitation on the doctrine is indicated in the italicized portion of the rule as set forth in Restatement of Torts, *supra*:

'Except as stated in §§ 521-4, one who carries on an ultrahazardous activity is liable to another whose person, land or chattels the actor should recognize as likely to be harmed by the unpreventable miscarriage of the activity for harm resulting thereto *from that*

which makes the activity ultrahazardous, although the utmost care is exercised to prevent the harm. (Italics supplied.)

This restriction which has been placed upon the application of the doctrine of absolute liability is based upon considerations of policy. As Professor Prosser has said:

‘* * * It is one thing to say that a dangerous enterprise must pay its way within reasonable limits, and quite another to say that it must bear responsibility for every extreme of harm that it may cause. The same practical necessity for the restriction of liability within some reasonable bounds, which arises in connection with problems of ‘proximate cause’ in negligence cases, demands here that some limit be set. * * * This limitation has been expressed by saying *445 that the defendant’s duty to insure safety extends only to certain consequences. More commonly, it is said that the defendant’s conduct is not the ‘proximate cause’ of the damage. But ordinarily in such cases no question of causation is involved, and the limitation is one of the policy underlying liability.’ Prosser on Torts, 457, § 60.

Applying this principle to the case before us, the question comes down to this: Is the risk that any unusual vibration or noise may cause wild animals, which are being raised for commercial purposes, to kill their young, one of the things which make the activity of blasting ultrahazardous?

We have found nothing in the decisional law which would support an affirmative answer to this question. The decided cases, as well as common experience, indicate that the thing which makes blasting ultrahazardous is the risk that property or persons may be damaged or injured by coming into direct contact with flying debris, or by being directly affected by vibrations of the earth or concussions of the air. Where, as a result of blasting operations, a horse has become frightened and has trampled or otherwise injured a person, recovery of damages has been upheld on the theory of negligence. [cc] Contra: Uvalde Construction Co. v. Hill, 142 Tex. 19, where a milkmaid was injured by a frightened cow. But we have found no case where recovery of damages caused by a frightened farm animal has been sustained on the ground of absolute liability.

If, however, the possibility that a violent vibration, concussion, or noise might frighten domestic animals and lead to property damages or personal injuries be considered one of the harms which makes the activity of blasting ultrahazardous, this would still not include the case we have here. *446 The relatively moderate vibration and noise which appellant’s blasting produced at a distance of two and a quarter miles was no more than a usual incident of the ordinary life of the community. See 3 Restatement of Torts, 48, § 522, comment a. The trial court specifically found that the blasting did not unreasonably interfere with the enjoyment of their property by nearby landowners, except in the case of respondent’s mink ranch.

It is the exceedingly nervous disposition of mink, rather than the normal risks inherent in blasting operations, which therefore must, as a matter of sound policy, bear the responsibility for the loss here sustained. We subscribe to the view expressed by Professor Harper (30 Mich.L.Rev. 1001, 1006, supra) that the policy of the law does not impose the rule of strict liability to protect against harms incident to the plaintiff’s extraordinary and unusual use of land. This is perhaps but an application of the principle that the extent to which one man in the lawful conduct of his business is liable for injuries to another involves an adjustment of conflicting interests. [c]

It may very well be that, under the facts of a particular case, recovery for damages of this kind may be sustained upon some theory other than that of absolute liability. In *Hamilton v. King County*, 195 Wash. 84, for example, recovery of such damages was sanctioned on the ground that defendant had trespassed upon plaintiff's land in doing the blasting which caused the disturbance.

Likewise, if the facts warrant, it is possible that such damages may be predicated upon a violation of RCW 70.74.250, cf. Rem.1941 Sup., § 5440-25, requiring notice to be given at certain times of the year when blasting is to be undertaken within fifteen hundred feet of any fur farm or commercial hatchery, except in certain cases. In *Maitland v. Twin City Aviation Corp.*, 254 Wis. 541, where a low-flying airplane frightened mink and loss of kittens resulted, recovery was allowed upon a showing that the airplanes were flown at an unlawfully low elevation. *447 In *Madsen v. East Jordan Irrigation Co.*, 101 Utah 552, recovery was denied under facts very similar to those of the instant case, on the ground that the mother mink's intervention broke the chain of causation.

It is our conclusion that the risk of causing harm of the kind here experienced, as a result of the relatively minor vibration, concussion, and noise from distant blasting, is not the kind of risk which makes the activity of blasting ultrahazardous. The doctrine of absolute liability is therefore inapplicable under the facts of this case, and respondent is not entitled to recover damages.

The judgment is reversed.

Note 1. What is the holding in this case?

Note 2. What does the court suggest (in dictum) about the possibility of recovery in future cases on similar facts?

Note 3. Practice stating how this opinion serves—or disserves—tort law's purposes. In so doing, take note of whether your normative view of the case matches or diverges from your intuitions about the facts. What do you notice about the relationship between framing the risks and harms in the fact pattern and determining whether tort law's larger purposes are served?

Check Your Understanding (1-4)

Question 1. True or false: The court's holding in *Foster v. Preston Mill Co.* (reversing the lower court's ruling in favor of the plaintiff on a theory of absolute liability) relies on the rationale that negligence only requires reasonable, not zealous, best efforts, which are satisfied here because the logging company *did* lower the strength of its blasts after being notified of the impact to the mink mothers and their kittens.

An interactive H5P element has been excluded from this version of the text. You can view it online here: <https://saidtorts2d.lawbooks.cali.org/?p=28#h5p-6>

Reflect On Your Understanding – Essay: Foster v. Preston Mill Co.

Essay: How would you explain your answer to the True or False inquiry in the preceding question, in 200 words or fewer?

An interactive H5P element has been excluded from this version of the text. You can view it online here: <https://saidtorts2d.lawbooks.cali.org/?p=28#h5p-7>

When you study proximate cause more deeply, under causation (in the full module on Negligence), you'll see that there are interrelated issues of strategic framing involved: if you define an activity by its harms, how you define its harms will dispose of the legal question. Consequently, it produces a feedback loop in which parties will try to define the harm and the risk strategically. (Stay tuned—this will make more sense when you encounter proximate cause. Note, for now that causation is always required: if a plaintiff cannot show that the defendant's actions—measured by whatever culpability level—caused their injury, the plaintiff will fail. Proximate cause often is more important in negligence law, partly because of the lower culpability standard imposed on defendants and negligence is the area of law in which proximate cause is traditionally taught. But proving proximate cause is always required, whether explicitly or implicitly.)

Check Your Understanding (1-5)

Question 1. Which (if any) of the following statements is true regarding the different regimes of tort law?

An interactive H5P element has been excluded from this version of the text. You can view it online here: <https://saidtorts2d.lawbooks.cali.org/?p=28#h5p-8>

As you will learn when you study Product Liability Law, some claims may be brought under strict liability. The Restatement (Third) limits “strict liability” for injuries caused by defective products based on the kind of defects alleged. If claims are based on manufacturing defect, strict liability applies; if the claims are based on design or warning defects, the Restatement articulates a different standard, more akin to negligence. For now, keep in mind that understanding the differences between these regimes will pay dividends later as your substantive knowledge deepens.

Chapter 4. Distinguishing Strict Liability from Negligence (Socratic Script)

You've now completed an overview of negligence and strict liability. This next case is longer by design, to give you practice with working through a dense opinion. The legal issues purposely overlap with some you have just worked through in prior cases, in order to give you the opportunity to recognize, build on and integrate the doctrines you are learning. A "Socratic script" follows, posing questions that allow you to simulate the kinds of questions a professor often asks in class. Somewhat similar to *Foster v. Preston Mills*, *Toms v. Calvary* involves the question of whether a particular aspect of recreational fireworks use triggers the imposition of strict liability. As you work through the case, keep in mind the questions below.

Questions and Areas of Focus for the Readings

- Identify the key arguments by the parties and note how the court evaluates those arguments.
- Do you understand the significance of the court's discussion of the standard of review?
- Observe how the court methodically applies the Restatement factors.
- How does the court deal with the jurisdictional split it identifies?

Toms v. Calvary Assembly of God, Inc. et al, Court of Appeals, Maryland (2016) (446 Md. 543)

In this case, we address whether noise emanating from the discharge of a fireworks display constitutes an abnormally dangerous activity, which would warrant the imposition of strict liability.

Petitioner, Andrew David Toms ("Toms"), operates a dairy farm in Frederick County, Maryland, and maintains a herd of approximately 90 head of cattle. On September 9, 2012, a church-sponsored fireworks display took place on property adjacent to Toms' dairy operation. A permit to discharge fireworks had been obtained, and the event was supervised by a deputy fire marshal. No misfires or malfunctions took place. According to Toms, the fireworks display was so loud that it startled his cattle, and caused a stampede inside his dairy barn. The stampede resulted in the death of four dairy cows, property damage, disposal costs, and lost milk revenue.

Toms filed suit against the respondents, collectively, Calvary Assembly of God, Inc. ("Calvary"), Zambelli Fireworks Manufacturing Co. ("Zambelli"), Zambelli employee Kristopher *546 Lindberg ("Mr. Lindberg"), and Auburn Farms, Inc. [fn] in the District Court of Maryland sitting in Frederick County ("District Court"). He alleged that the stampede was the result of negligence, nuisance, and strict liability for an abnormally dangerous activity. After a bench trial, the District Court entered judgment in favor of the respondents. Toms appealed to the Circuit Court for Frederick County ("Circuit Court"). The Circuit Court affirmed the lower court's ruling. We granted Toms' petition for

writ of certiorari, *Andrew David Toms v. Calvary Assembly of God, Inc.*, 442 Md. 515 (2015). For the reasons explained below, we hold that lawfully discharging fireworks is not an abnormally dangerous activity, and, therefore, the imposition of strict liability is unwarranted. We affirm the judgment of the Circuit Court.

FACTUAL AND PROCEDURAL BACKGROUND

Toms operates a dairy farm on 69 acres of leased property near Walkersville, Frederick County, Maryland. The farm includes a barn and a herd of approximately ninety dairy cows. Auburn Farms, Inc., at the time of the incident, possessed the adjacent 40 acre property. Calvary sought and obtained permission from Auburn Farms, Inc. to use its property to host a fireworks display celebrating a church youth crusade.⁴ Calvary then hired Zambelli, a professional fireworks company, to handle the fireworks.

Pursuant to Md. Code (2003, 2011 Repl. Vol.), § 10–104(b) of the Public Safety Article, an application for a permit to discharge fireworks was submitted to the Office of the State Fire Marshal. The application identified the date, time, and location of the anticipated fireworks display, as well as the size and number of fireworks shells that would be used. It also *547 identified Mr. Lindberg as the Zambelli employee who would be responsible for discharging the fireworks, and included his “State shooter permit”⁵ information, and proof of Zambelli’s insurance for the event. Deputy Fire Marshal Glen Ruch inspected Auburn Farms, Inc. and [***][t]he application was approved, including the [extended] 300 foot firing radius, and a permit to discharge fireworks was obtained by the respondents.

The event was open to the public, and advertised in radio interviews, a newspaper ad, and on a banner located on Calvary’s property on Route 194. Toms recalls seeing the banner, but states he had no notice of the event’s time or location. [***] The fireworks display took place at *548 8:30 p.m., and Senior Deputy Fire Marshal Michael Guderjohn was onsite to supervise the event. Apparently, 250 shells were discharged over a fifteen-minute period without any misfires or duds. According to the parties’ Agreed Statement of Facts submitted in their briefs to this Court, there is no dispute that Toms’ barn was at least 300 feet away from the firing location. [fn]

At the time of the event, Toms’ cattle were inside the barn. Toms, however, arrived at the barn a few minutes after Mr. Lindberg began discharging fireworks. Toms states that the explosions startled his dairy cows, and caused them to stampede inside the barn. No witnesses, however, actually saw the stampede because no one was inside the barn with the cattle at the time the event started. The stampede, Toms states, resulted in the deaths of three cows shortly thereafter, and injuries to a fourth cow that ultimately led to its death, because it had to be “culled” from the herd a few weeks later. [fn] In addition to the loss of four dairy cows, Toms sustained property damage to fences and gates, disposal costs, and lost milk revenue. Toms sent a demand letter to Calvary outlining the damages, but Calvary and Zambelli denied liability.

On December 9, 2013, Toms filed suit in District Court against the respondents seeking damages of \$13,148.20 under the theories of negligence, nuisance and strict liability for an abnormally dangerous

⁴ Toms’ relatives and landlord were also contacted by Calvary, but all declined permission to allow Calvary to host the event on their property.

⁵ Firework shooters must be certified in the State of Maryland. Applicants must submit a “Firework Shooter Testing and Permit Application” to the Office of the State Fire Marshal in order to “to possess, sell or use explosives of any kind in the State of Maryland.”

activity. On May 2, 2014, a one-day *549 bench trial took place in the District Court before Judge W. Milnor Roberts. Several witnesses testified on Toms' behalf, including his dairy veterinarian, Dr. Richard Doak, and lay witnesses with experience handling cattle. At the time of the event, the lay witnesses were located nearby the barn, and they testified about the loudness of the fireworks display, and hearing "banging" noises emanating from the barn at the time of the alleged stampede. Dr. Doak testified, among other things, about the tendency of loud unexpected noises to trigger a "startle response" in cows, which can lead to a stampede as well as injuries if a herd is confined to a small space. [***]

The District Court entered judgment in favor of the respondents. It found that although Toms sustained damage, Toms did not establish any basis for liability for the injuries to his property, including livestock. The District Court determined that the fireworks display was a single event with no evidence that injuries or damages were sustained by direct contact with the discharged shells. No evidence established negligence on behalf of the respondents, because they had lawfully complied with statutory requirements by obtaining a permit, and the conditions of the permit were not violated. As to the issue of strict liability, the District Court found that the discharge of fireworks could be an abnormally dangerous activity, but that the danger is contained within the area allowed by the permit: here, a 300 foot firing radius. The District Court, however, *550 did not find that noise from a fireworks discharge itself was abnormally dangerous. Furthermore, it reasoned, strict liability for an abnormally dangerous activity could not be imposed, because Toms' barn was not located within 300 feet of the firing location.

[***] [T]he Circuit court affirmed the District Court's judgment. Although it held that the use of fireworks was abnormally dangerous as to the damage from explosions, the Circuit Court stated that the respondents "are not strictly liable because the type of harm—damage caused by noise—is not of a type that makes the activity abnormally dangerous." Under the theory of negligence, it found no evidence to show that the respondents breached any duty of care. There was substantial evidence to show that the respondents "acted reasonably and with due care in preparing [and discharging] the fireworks display." Lastly, the Circuit Court held that the theory of private nuisance was inapplicable, because, as a one-time event, "the fireworks were not substantial and unreasonable and did not rise to the level of significant harm needed to create a private nuisance." [fn]

We granted *certiorari* ... to answer the following question:

Does the doctrine of strict liability for an abnormally dangerous activity apply to the noise of a fireworks discharge, based on the facts of this case?

*551 For the reasons stated below, we shall answer in the negative. Accordingly, we affirm the judgment of the Circuit Court, and agree that there is no liability for abnormally dangerous activities, but for reasons different than those articulated by the Circuit Court.

STANDARD OF REVIEW

The question before this Court is whether discharging fireworks—specifically, the noise it produces—is abnormally dangerous, and thus, subject to strict liability. Whether an activity constitutes an abnormally dangerous activity is a question of law. RESTATEMENT (SECOND) OF TORTS § 520 cmt. 1 (AM. LAW INST. 1977) (stating that the function of the court is to decide whether an activity is abnormally dangerous by considering several factors and "the weight given to each that it merits

upon the facts in evidence”). “As with all questions of law, we review this matter *de novo*.” [c] *Gallagher v. H.V. Pierhomes, LLC*, 182 Md.App. 94, 109 (2008).

For questions of fact for an action tried without a jury, we apply a clearly erroneous standard. Md. Rule 8–131(c) states:

When an action has been tried without a jury, the appellate court will review the case on both the law and the evidence. It will not set aside the judgment of the trial court on the evidence unless clearly erroneous, and will give due regard to the opportunity of the trial court to judge the credibility of the witnesses.

“On appellate review, the Court of Appeals may set aside the judgment of the lower court based on the factual findings of the lower court only when those findings are clearly erroneous.” *Helinski v. Harford Mem’l Hosp., Inc.*, 376 Md. 606, 614, 831 A.2d 40, 45 (2003) (citing Md. Rule 8–131(c)).

DISCUSSION

Maryland has long recognized the doctrine of strict liability, which does not require a finding of fault in order to ***552** impose liability on a party. See *Yommer v. McKenzie*, 255 Md. 220, 222 (1969); *Toy v. Atl. Gulf & Pac. Co.*, 176 Md. 197 (1939). The doctrine is derived from the famous 1868 English case of *Rylands v. Fletcher*, which recognized that, under certain circumstances, no-fault liability could be imposed.⁶ [***] The modern formulation of the strict liability doctrine is found in the Restatement (Second) of Torts §§ 519–520 (1977). This Court adopted that formulation in *Yommer*, while the Restatement (Second) of Torts was still in its tentative draft. 255 Md. at 223–24, 257 A.2d at 139. [***]

Restatement (Second) of Torts § 519 defines strict liability for an abnormally dangerous activity:

One who carries on an abnormally dangerous activity is subject to liability for harm to the person, land or chattels of another resulting from the activity, although he has exercised the utmost care to prevent the harm.... This strict liability is limited to the kind of harm, the possibility of which makes the activity abnormally dangerous.

To determine whether an activity is abnormally dangerous, a court uses six factors. ***553** These factors are:

- (a) existence of a high degree of risk of some harm to the person, land or chattels of others;
- (b) likelihood that the harm that results from it will be great;
- (c) inability to eliminate the risk by the exercise of reasonable care;
- (d) extent to which the activity is not a matter of common usage;
- (e) inappropriateness of the activity to the place where it is carried on; and
- (f) extent to which its value to the community is outweighed by its dangerous attributes.

⁶ “Dean Thayer pointed out the error in the popular assumption that the rule of *Rylands v. Fletcher* makes the defendant liable for all consequences in fact resulting from his conduct. This is precisely what the rule of the case does *not* do; it makes [the] defendant liable ... only for proximate consequences, not for remote consequences.” Fowler v. Harper, *Liability Without Fault and Proximate Cause*, 30 MICH. L.REV. 1001, 1005 (1932) (emphasis in original).

RESTATEMENT (SECOND) OF TORTS § 520 (AM. LAW INST. 1977). [***] As the Restatement (Second) of Torts reminds us:

Because of the interplay of these various factors, it is not possible to reduce abnormally dangerous activities to any definition. The essential question is whether the risk created is so unusual, either because of its magnitude or because of the circumstances surrounding it, as to justify the imposition of strict liability for the harm that results from it, even though it is carried on with all reasonable care.

RESTATEMENT (SECOND) OF TORTS § 520 cmt. f (AM. LAW INST. 1977). The Reporter's Note for this section identifies typical abnormally dangerous activities, such as the storage of large quantities of water or explosives in dangerous locations, and conducting blasting operations in the middle of a city.

In Maryland, we weigh each factor independently. More emphasis is placed on the fifth factor: the appropriateness of the activity in relation to its location. *Yommer*, 255 Md. at 226. "The thrust of the doctrine is that the activity be abnormally dangerous in relation to the area where it occurs." [***] In *Yommer*, the owners of a gasoline station were held strictly liable for damages resulting from gasoline contamination of the well water of an adjacent residential property. 255 Md. at 227. There, we applied the Restatement factors, and found the fifth factor to be the most persuasive factor:

No one would deny that gasoline stations as a rule do not present any particular danger to the community. However, when the operation of such activity involves the placing of a large tank adjacent to a well from which a family must draw its water for drinking, bathing and laundry, at least that aspect of the activity is inappropriate to the locale, even when equated to the value of the activity. *Yommer*, 255 Md. at 225.

"We accept the test of appropriateness as the proper one: that the unusual, the excessive, the extravagant, the bizarre are likely to be non-natural uses which lead to strict liability." *Yommer*, 255 Md. at 226.

In applying the six factors, it is not necessary to have all six factors weigh in favor of a particular party. "Any one of them is not necessarily sufficient of itself in a particular case, and ordinarily several of them will be required for strict liability. On the other hand, it is not necessary that each of them be present, especially if others weigh heavily." RESTATEMENT (SECOND) OF TORTS § 520 cmt. f (AM. LAW INST. 1977).

Though the doctrine of strict liability has evolved since the rule in *Rylands* was first announced, [fn] the policy concerns in *555 favor of limiting its application remain. Previously, when this Court was still applying the rule in *Rylands*, this Court noted that without strict limitations, "the rule would impose grievous burdens as incident to the ownership of land..." *Toy*, 176 Md. at 213. In *Rosenblatt*, we discussed the nature of the limitations on the doctrine:

We have taken care to limit the application of this doctrine because of the heavy burden it places upon a user of land. Our cases have limited the class of abnormally dangerous activities to those activities which would be abnormally dangerous in relation to the area where they occur. Moreover, we have limited the doctrine with regard to the class of actors to which it applies: we have required that the one engaging in the relevant

activity have ownership or control over the land.... And, finally, we have required that the act have a relation to the occupation or ownership of land. 335 Md. at 73–74 (internal citations omitted).

In *Kelley*, we refused to apply the doctrine in a case involving a minor’s death caused by the firing of a handgun. 304 Md. at 133. “The dangers inherent in the use of a handgun in the commission of a crime ... bear no relation to any occupation or ownership of land. Therefore, the abnormally dangerous activity doctrine does not apply to the manufacture or marketing of handguns.” *Id.* [***]

In *Gallagher v. H.V. Pierhomes, LLC*, the Court of Special Appeals held that pile driving was not an abnormally dangerous activity. 182 Md.App. 94, 113 (2008). There, pile driving operations at the Inner Harbor in Baltimore City caused minor damage in a 200 year old residence located 325 feet away from the construction site. *Gallagher*, 182 Md.App. at 110. The intermediate appellate court found that the defendants had acted appropriately in obtaining the proper permits, conducting geotechnical studies, and carefully monitoring the vibrations produced by the pile driving operations. “[T]here was only a single recorded vibration that exceeded the limits.” *Gallagher*, 182 Md.App. at 99–100. The court concluded that the risk of harm produced by pile driving operations “is not a high degree of risk which requires the application of strict liability” because that risk can be eliminated “through the exercise of ordinary care.” *Gallagher*, 182 Md.App. at 110.

Jurisdictional Split on Strict Liability and Fireworks

Whether fireworks discharge constitutes an abnormally dangerous activity is a case of first impression in Maryland, because fireworks liability normally arises in the context of nuisance and negligence litigation.⁷ Some jurisdictions, however, *557 have addressed the issue of whether fireworks are abnormally dangerous. As evidenced by the cases below, litigation often came to fruition due to a malfunction or misfire at a fireworks display, which resulted in spectator injuries. Although fireworks liability cases often share similar facts, jurisdictions disagree on whether discharging fireworks is an abnormally dangerous activity, as evident by the split of legal authority on the matter.

The highest appellate court in Washington, for instance, held pyrotechnicians strictly liable when a shell exploded improperly and injured spectators at a public fireworks show. *Klein v. Pyrodyne Corp.*, 117 Wash.2d 1, *amended by* 117 Wash.2d 1 (1991). It stated that Restatement factors (a) through (d) weighed in favor of imposing strict liability, because discharging fireworks creates a “high risk of serious bodily injury or property damage” due to the possibility of a malfunction or similar issue. *Klein*, 810 P.2d at 922. “The dangerousness ... is evidenced by the elaborate scheme of administrative regulations with which pyrotechnicians must comply[,]” including licensing and insurance requirements. *Id.* at 920. Under factor (d), it further determined that discharging fireworks was not a matter of common usage, because the licensing scheme restricts the general public from engaging in that activity. *Id.* at 921. In addition to the high risk discharging fireworks creates, that court determined that public policy and fairness warranted strict liability. *Id.* at 922. Otherwise, the injured

⁷ Under certain circumstances, causes of action may exist in cases involving fireworks liability under the theories of negligence or nuisance. See *Crowley v. Rochester Fireworks Co.*, 183 N.Y. 353 (1906) (“[T]here may be negligence in the character of the fireworks used on a particular occasion as well as in the method of their discharge.”); *Little v. Union Trust Co. of Maryland*, 45 Md.App. 178, 183 (1980) (discussing possible nuisance liability for shooting fireworks in the street).

spectators would have been subject to the “problem of proof” because “all evidence was destroyed as to what caused the misfire of the shell that injured the Kleins.”

Arizona’s intermediate appellate court was persuaded by the rationale in *Klein* in a case involving a misfire at a mall-sponsored fireworks display. *Miller v. Westcor Ltd. P’ship*, 171 Ariz. 387 (Ct.App.1991). Although the issue was in the context of negligence liability under § 427 of the Restatement (Second) of Torts, like *Klein*, it found that the risk of malfunction or misfire could not be entirely eliminated, and that the “legislature has also recognized the dangerousness *558 of fireworks by regulating their use” as reflected in a “statutory requirement that a pyrotechnician obtain a surety bond or certificate of insurance for at least \$1,000,000 in order to obtain a license to conduct a public fireworks display.” *Miller*, 831 P.2d at 391–92. Therefore, it held that public fireworks displays were an inherently dangerous activity.

Other jurisdictions, however, have come to the opposite conclusion, and have held that the level of risk involved with a fireworks discharge does not warrant strict liability. In *Haddon v. Lotito*, Pennsylvania’s highest appellate court applied the ultrahazardous activity test, and determined that strict liability—referred to as absolute liability—did not apply in a case involving spectator injuries at a public fireworks display. 399 Pa. 521 (1960). Critically, that court distinguished lawful from unlawful fireworks displays:

[A] public fireworks display, handled by a competent operator in a reasonably safe area and properly supervised (and there is no proof to the contrary herein), is not so dangerous an activity.... Where one discharges fireworks illegally or in such a manner as to amount to a nuisance and causes injury to another, some jurisdictions have held that liability follows without more. But the production of a public fireworks display, under the circumstances presented herein, is neither illegal nor a nuisance and, consequently, liability, if existing, must be predicated upon proof of negligence. *Id.* (internal citations omitted).

Other courts have ruled similarly. In *Litzmann v. Humboldt Cty.*, California’s intermediate appellate court determined that “the handling and discharge of fireworks ... were not such as to come within the definition of ultrahazardous activities.” 273 P.2d 82, 88 (Cal.Dist.Ct.App.1954). In that case, an undischarged firework was negligently discarded on fairgrounds, and a minor was severely injured when he found and ignited it. After applying the Restatement factors, that court declined to impose strict liability, because “[i]t was the failure of care that caused the injuries and not the nature of the risks involved.” *Litzmann*, 273 P.2d at 88.

*559 [T]hese risks could be eliminated by a degree of care far within the bounds of ‘utmost care’.... [B]y the method of firing adopted[,], it was a reasonably easy matter to direct the firing so that injury would not arise through misdirection of the missiles; and that observation by those skilled enough to be licensed to explode fireworks was adequate to detect the lack of explosion of the material shot into the air. It appears, therefore, that the activities engaged in and charged to be ultrahazardous were in fact risks which could be and would be eliminated if commensurate care had been exercised. *Id.*

In *Cadena v. Chicago Fireworks Mfg. Co.*, the Illinois intermediate appellate court stated that only Restatement factors (a), which focuses on the existence of a high degree of risk of some harm, and (b), which concerns the likelihood that the harm that results will be great, weighed in favor of strict liability. 297 Ill.App.3d 945 (1998) *overruled on other grounds by Ries v. City of Chicago*, 242 Ill.2d 205

(2011). Notably, that court reminded readers that factor (c) “does not require the reduction of *all* risk” and that “the exercise of reasonable care in displaying fireworks will significantly reduce the risks involved [in a fireworks display].” *Cadena*, 232 Ill.Dec. 60, 697 N.E.2d at 814 (emphasis in original). Unlike other courts, it interpreted factor (d) broadly and found that “fireworks displays *are* a matter of common usage” because “many individuals view them and many municipalities display fireworks....” *Id.* (emphasis in original).

Fireworks Liability in Maryland

In the instant case, Toms asks this Court to expand the strict liability doctrine and hold that noise emanating from a fireworks discharge is abnormally dangerous to livestock.⁸ *560 [***]

Toms argues that the facts of the case are sufficient to show that each [of the Restatement factors] weighs in favor of imposing strict liability. He maintains that the resulting sudden loud explosions, for example, involve a high risk of harm that can trigger a startle reflex in dairy cows, which are known to be large, clumsy animals. That startle reflex may cause, as Toms alleges happened here, the cows to stampede and cause injuries to themselves as well as to property. Under factor (c), Toms posits that there is no way to eliminate this risk other than by choosing an alternative location to host the fireworks display. He also argues that the risk can be mitigated with advanced notice to the owner of the dairy cows of the fireworks display. For instance, Toms states that he was never given specific or general notice aside from a banner on Calvary’s property advertising the event. With advanced notice, Toms contends he could have mitigated the risks by moving the cows from the barn to an outdoor enclosure. Toms further argues that factor (d) weighs in his favor, because although “fireworks displays at public parks, ballparks, and the like, are common, exploding fireworks adjacent to an active dairy farm is not.” Additionally, under factor (e), discharging fireworks 300 to 500 *561 feet from a herd of cattle, in Toms’ view, “is a disaster waiting to happen” and therefore, is not an appropriate location.

For support, Toms cites to *Toy v. Atl. Gulf & Pac. Co.*, and its discussion of liability without fault when an “occupier was not using the land in the common and natural way, and had artificially produced the potential danger....” 176 Md. 197, 213 (1939). Toms states that the property of Auburn Farms, Inc. was not being used in the “common and natural way” because it was hosting a one-time event. Toms further argues that under factor (f), a local church activity provides little benefit to the community, and does not outweigh the risks associated with the fireworks display to the adjacent dairy farm operation. Lastly, in addition to the Restatement factors, Toms highlights important policy considerations. “Because of population growth in Maryland, the interaction [between] farmers and development is a continuing issue.... Expanding Maryland case law to provide protection for farmers against damages from such abnormal intrusion would meet a social need.” Toms argues that he sustained a preventable injury, and if the court does not impose strict liability, it shall remain an injury without remedy.

The respondents contend that the lower courts were correct in determining that, based on the facts of this case, strict liability is inapplicable, because evidence is insufficient to support Toms’ claim that the noise produced by the fireworks discharge is abnormally dangerous to livestock. As support, the respondents cite to Md. Code (2003, 2011 Repl. Vol.), §§ 10–101 *et seq.* of the Public Safety Article

⁸ In the petition for writ of certiorari, Toms states “This Court ... can expand the factual application of this tort to instances where the sudden, abnormal noise of a fireworks display, adjacent to livestock, can create strict liability.”

as evidence that the General Assembly “has already regulated the use of fireworks, and it does not afford protection to the chattel for noise.”

Furthermore, they posit, the Restatement factors do not support expanding the doctrine of strict liability for abnormally dangerous activities. In their view, all the factors weigh in favor of the respondents. Under factor (a), there is not a high degree of risk associated with the discharge of fireworks, because the use of fireworks is heavily regulated: a deputy fire marshal inspected and authorized the firing location, and testified that the respondents lawfully complied with the permitting *562 process; the respondents obtained a permit for the event; Mr. Lindberg voluntarily extended the firing radius an additional 50 feet beyond the State’s requirement; a senior deputy fire marshal supervised the event, and testified that the shells were properly discharged with no misfires or duds. Furthermore, the respondents contend that Toms did not provide evidence that the risk of cows stampeding due to sudden loud noise is commonly known. Under factor (b), the most common risks associated with a fireworks display—mishandling, misfires, and malfunctions—did not occur in the instant case. There is no evidence of the foreseeability of a herd of dairy cows suffering great harm from a fireworks display. In the past, similar fireworks displays have taken place in close proximity to Toms’ dairy farm operation without apparent incident. Factor (c) is resolved in the respondents’ favor, they suggest, because Toms was aware of the event. Lastly, the respondents state that factors (d) through (f) do not weigh in favor of strict liability, because fireworks displays are a frequent event in the city of Walkersville, the event was open to the public, and applicable laws were not violated. No noise ordinances were violated and advanced notice to Toms was not required.

In applying the clearly erroneous standard as it applies to questions of fact, we are satisfied with the evidentiary findings made by the District Court. There was sufficient evidence in the record to support those findings. Therefore, we need only review *de novo* the question of law for the issue of whether strict liability for an abnormally dangerous activity should be imposed on a lawful fireworks display.

Maryland defines fireworks as “combustible, implosive or explosive compositions, substances, combinations of substances, or articles that are prepared to produce a visible or audible effect by combustion, explosion, implosion, deflagration, or detonation.” Md. Code (2003, 2011 Repl. Vol.), § 10–101(f) of the Public Safety Article. We disagree with Toms that our analysis should be so narrow as to focus solely on the audible component—the noise produced—by a fireworks display. In the petition for writ of certiorari, Toms refers to the *563 “noise of a fireworks discharge,” but the noise itself is a by-product of the activity of discharging fireworks. By definition, under § 10–101(f) of the Public Safety Article, fireworks “are prepared to produce a visible or audible effect...” Therefore, when applying the multi-factor test from § 520 of the Restatement (Second) of Torts, we will consider all the characteristics and the nature of the risks associated with discharging fireworks. After all, we are also mindful that “[o]ne who carries on an abnormally dangerous activity is not under strict liability for every possible harm that may result from carrying it on.” RESTATEMENT (SECOND) OF TORTS § 519 cmt. e (AM. LAW INST. 1977). We apply the Restatement factors to the instant case:

(a) existence of a high degree of risk of some harm to the person, land or chattels of others. Special events requiring the use of large, professional “display fireworks” are heavily regulated in Maryland pursuant to §§ 10–101 *et seq.* of the Public Safety Article. [***] We hold that a lawful fireworks display does not pose a high degree of risk, because the statutory scheme in place is designed to significantly reduce the risks associated with fireworks, namely mishandling, misfires, and malfunctions. [***] Critically, in enacting the Public Safety Article, the General Assembly did not

regulate the audible effects of display fireworks, which indicates that any risk associated with the decibel level of a fireworks discharge is minimal or non-existent.

Lawful fireworks displays do not pose a significant risk because “[a] person who possesses or discharges fireworks in violation” of the permitting process “is guilty of a misdemeanor and on conviction is subject to a fine not exceeding \$250 for each offense.” Md.Code (2003, 2011 Repl.Vol.), § 10–111(a) of the Public Safety Article. To impose a relatively light penalty for an unlawful fireworks display is telling. If an unlawful fireworks display is only a misdemeanor offense with no possibility of incarceration, why then should strict liability be imposed for risks associated with a lawful fireworks display?

(b) likelihood that the harm that results from it will be great. This factor also weighs in favor of not imposing strict liability, because the purpose of a 300 foot perimeter surrounding the firing location is to mitigate the likelihood of harm. The instructions sheet attached to the “Application for Public Fireworks Display” states, in pertinent part:

If other properties are in the fall out zone of the fireworks, a letter must be attached from the property owner or representative of the property owner stating that they give *565 permission for their property to be used in the fall out zone. If any structures are within the fall out zone, the owner of the structure must provide documentation that the structure will not be occupied during the fireworks display. All structures within the fall out zone shall be deemed as being unimportant.

The statutory scheme regulating the use of fireworks is specifically designed to reduce risk. “The harm threatened must be major in degree, and sufficiently serious in its possible consequences to justify holding the defendant strictly responsible for subjecting others to an unusual risk. It is not enough that there is a recognizable risk of some relatively slight harm....” RESTATEMENT (SECOND) OF TORTS § 520 cmt. g (AM. LAW INST. 1977). [***] Because Toms’ dairy barn, and therefore his cows, were not located within the fall out zone, the likelihood of harm to the public and property was significantly reduced. The 300 foot firing radius was effective because no shells fired that night malfunctioned, and no debris littered Toms’ property.

(c) inability to eliminate the risk by the exercise of reasonable care. We are reminded that:

It is not necessary, for the factor stated in Clause (c) to apply, that the risk be one that no conceivable precautions or care could eliminate. What is referred to here is the unavoidable risk remaining in the activity, even though the actor has taken all reasonable precautions in advance and has exercised all reasonable care in his operation, so that he is not negligent.

RESTATEMENT (SECOND) OF TORTS § 520 cmt. h (AM. LAW INST. 1977). We disagree with Toms that reasonable care cannot reduce the risk of harm to livestock to acceptable levels. In enacting §§ 10–101 *et seq.* of the Public Safety Article, the General Assembly took care to implement sufficient precautions *566 so as to ensure that lawful fireworks displays can be a safe and enjoyable activity. [***] Health and safety, therefore, are of paramount concern, and we are satisfied that the regulations sufficiently protect the public and property. Only qualified professional fireworks companies and their agents—authorized shooters—may apply for a permit. The requirements of mandatory insurance coverage, a physical site inspection, and event supervision is evidence of reasonable care that reduces

the risk of harm. The site inspection and prior approval of an authority having jurisdiction ensures that the firing location is appropriate and that injury is unlikely. Importantly, additional measures are required if other properties are located within the fall out zone, including notice and permission from that property owner for their property to be used in the fall out zone. The 300 foot firing radius is sufficient. Furthermore, notice to Toms was not necessary, because his dairy barn was located beyond the firing radius. In our view, the Restatement does not require the elimination of all risk, and because the risks inherent with a fireworks discharge can be reduced to acceptable levels, this factor does not support a conclusion of an abnormally dangerous activity.

(d) extent to which the activity is not a matter of common usage. “An activity is a matter of common usage if it is customarily carried on by the great mass of mankind, or by many people in the community.” *Yommer*, 255 Md. at 225 n. 2 (citation omitted). We recognize that the discharging of lawful fireworks displays is a matter of common usage.

In a letter dated July 3, 1776, John Adams wrote about the pomp and circumstance that should surround the *567 celebration of our Nation’s independence:

“I am apt to believe that it will be celebrated, by succeeding Generations.... It ought to be solemnized with ... Bonfires and Illuminations from one End of this Continent to the other from this Time forward forever more.”⁹

As stated in § 10–101 of the Public Safety Article, fireworks are designed “to produce a visible or audible effect” for the benefit of spectators. Therefore, we define “common usage,” as it pertains to this case, broadly to include not only the professionals who discharge fireworks, but also the spectators who partake in the fireworks display. Almost by definition, lawful fireworks displays involve two parties: the shooter and the audience. We conclude that lawful fireworks displays are a matter of common usage. [fn] *See also Cadena*, 232 Ill.Dec. 60 (determining that the “social utility” of fireworks displays to communities “is not outweighed by its dangerous attributes.”).

(e) inappropriateness of the activity to the place where it is carried on. When this Court adopted the Restatement (Second) of Torts’ multi-factor test for abnormally dangerous activities, this particular factor was identified as being the most crucial. *Yommer*, 255 Md. at 225. “The thrust of the doctrine is that the activity be abnormally dangerous in relation to the area where it occurs.” *Kelley*, 304 Md. at 133. Implicit in the granting of a permit to discharge fireworks, is the lawfulness of that proposed *568 fireworks display. *See* § 10–103(a) of the Public Safety Article (“[T]he State Fire Marshal may issue a permit to authorize the discharge of fireworks in a place where the discharge of fireworks is legal.”). [***] Additionally, Senior Deputy Fire Marshal Guderjohn testified that previous fireworks displays had taken place within a mile of Toms’ dairy barn. Notably, Frederick County does not have a noise ordinance regulating the decibel level of fireworks. If Frederick County enacted regulations further restricting the use of fireworks, the respondents would be obliged to comply with those regulations in addition to applicable State laws. After all, pursuant to § 10–103(c)(1) of the Public Safety Article, a permit to discharge fireworks “does not authorize the holder of the permit to possess or discharge fireworks in violation of an ordinance or regulation of the political subdivision where the fireworks are to be discharged....” In sum, we do agree that a lawful fireworks display does not fall

⁹ *Letter from John Adams to Abigail Adams, 3 July 1776*, MASS. HIST. SOC’Y, www.masshist.org/digitaladams/archive/doc?id=L17760703_jasecond [<https://perma.cc/P22L-DMRX>].

within the context of “the unusual, the excessive, the extravagant, the bizarre non-natural uses which lead to strict liability.” *Yommer*, 255 Md. at 226,.

(f) extent to which its value to the community is outweighed by its dangerous attributes. Here, a church-sponsored fireworks display celebrated a youth crusade, and the event was open to the public. As a symbol of celebration, fireworks play an important role in our society, and are often met with much fanfare. The statutory scheme regulating its use minimizes the risk of accidents, thus, reinforcing the popularity of these displays. This Court recognizes that not all segments of the population may enjoy fireworks displays, especially those with noise sensitivities, however, we conclude *569 that the social desirability of fireworks appears to outweigh their dangerous attributes.

Policy considerations. We are mindful that the doctrine of strict liability for abnormally dangerous activities is narrowly applied in order to avoid imposing “grievous burdens” on landowners and occupiers of land. *Toy*, 176 Md. at 213. Toms argues that we should expand the factual application of this doctrine, however, the Restatement factors do not support such a position. The use of fireworks, especially in public fireworks displays, is heavily regulated pursuant to §§ 10–101 *et seq.* of the Public Safety Article. Under § 10–103, a permit to discharge fireworks cannot be obtained *unless* the State Fire Marshal determines that proposed fireworks display will “not endanger health or safety or damage property....” In light of this policy, the respondents cannot be held strictly liable, because they lawfully complied with the conditions of the permit as well as applicable laws. We are persuaded by the rationale in *Haddon*: “a public fireworks display, handled by a competent operator in a reasonably safe area and properly supervised (and there is no proof to the contrary herein), is not so dangerous an activity.” 161 A.2d at 162.

At issue in this case is a lawful fireworks display that was implemented pursuant to the requirements of the Public Safety Article. At trial, Toms did not present any evidence concerning what noise levels should be appropriate for public fireworks display. Sufficient evidence was not presented to the trier of fact that a lawful fireworks display was abnormally dangerous to livestock. Thus, as a matter of law and on a case-by-case basis, we do not extend the doctrine of strict liability for abnormally dangerous activities under the circumstances.

CONCLUSION

Accordingly, we affirm the judgment of the Circuit Court. Lawful fireworks displays are not an abnormally dangerous activity, because the statutory scheme regulating the use of *570 fireworks significantly reduces the risk of harm associated with the discharge of fireworks. Furthermore, it is not the province of the Judiciary, but rather, the Legislature to determine zoning classifications and enact noise ordinances that would further regulate the use of fireworks.

PETITIONER TO PAY THE COSTS.

Note 1. What is the law *descriptively* regarding fireworks in Arizona, Pennsylvania and Washington? *Normatively*, do you think the court reaches the correct conclusion with respect to Maryland? Why or why not?

Note 2. Tort law is often local; rulings may reflect a jurisdiction’s values and priorities. Consider the role the setting played in *Garcia v. Halsett* and *Foster v. Preston Mill Co.* What’s at stake in the fight over whether the noise produced by fireworks will be subject to strict liability in Maryland?

Note 3. Why might the District Court have focused on the lack of “direct contact with the discharged shells”?

Expand On Your Understanding – Socratic Script: *Toms v. Calvary*

Question 1. What is the legal question in *Toms v. Calvary*, and what is the holding? (This is intended to be a straightforward question.)

An interactive H5P element has been excluded from this version of the text. You can view it online here: <https://saidtorts2d.lawbooks.cali.org/?p=30#h5p-9>

Question 2. What is the significance, for a trial court, of the question of whether the determination of “abnormally dangerous activities” is a question of law or fact? How does the answer to this question differ for an appellate court?

An interactive H5P element has been excluded from this version of the text. You can view it online here: <https://saidtorts2d.lawbooks.cali.org/?p=30#h5p-10>

Question 3. The Restatement (Second) of Torts, Sec. 520, lists six factors to determine whether an activity is abnormally dangerous. The third factor, (c), considers inability to eliminate the risk through the exercise of reasonable care. Why do you think this inquiry exists as part of the strict liability determination?

An interactive H5P element has been excluded from this version of the text. You can view it online here: <https://saidtorts2d.lawbooks.cali.org/?p=30#h5p-11>

Question 4. To bring the fact pattern of *Toms* into the realm of a successful negligence action, what sorts of facts might the plaintiff have to prove? Give an example of one or two changes to the fact pattern that would make a negligence action plausible.

An interactive H5P element has been excluded from this version of the text. You can view it online here: <https://saidtorts2d.lawbooks.cali.org/?p=30#h5p-12>

Check Your Understanding (1-6)

Question 1. Parties may choose to litigate the issue of whether strict liability can apply because:

An interactive H5P element has been excluded from this version of the text. You can view it online here: <https://saidtorts2d.lawbooks.cali.org/?p=30#h5p-13>

This next question involves policy-oriented analysis and you may not have done very much of this yet in law school. Do your best to work through it and know that you will gain high competency in this style of analysis by the end of the term, even if it's a little unfamiliar to you at the moment.

Reflect On Your Understanding – Essay: Toms v. Calvary

Essay: Do you think this case is rightly or wrongly decided? Why? Your answer should include *descriptive* analysis (address the law as you understand it to be so far, what the law *is*) as well as prescriptive or *normative* analysis (what you think the law *should be*, based on a policy rationale). (Recommended maximum, 200 words)

Distinguish your *intuitive* response (if you feel the outcome seems unfair, or you hate fireworks... or you loathe cows) from your *descriptive* reading of the case law (cases assigned in the readings and cases cited in *Toms*).

As a policy matter, what do you think the court *should do normatively*, that is, based on policy reasons? You can raise any kind of policy argument that makes sense to you here, for example:

- a) an **institutional competence** argument about the court versus the legislature deciding this issue;
- b) an argument based in **doctrine**, on the likely impact of expanding strict liability on these facts, or choosing not to do so;
- c) an argument rooted in **socioeconomic and cultural values** (weighing the competing priorities of fireworks fans, churchgoers and farmers or other property owners, for instance);
- d) an **economic or utilitarian argument** oriented towards efficiency;
- e) an argument from **policy** in some other form.

Chapter 5. Introduction to the Intentional Torts: Protecting Property, Body, and Mind

Part I. Protecting Property and Bodily Integrity

Thus far, the standards of tort liability you've learned about have hinged on fault or policy fiat based on determinations of levels of risk. With these materials, we shift gears and introduce **different inquiries into the conduct of the defendant**, as well as the **intentionality behind that conduct**. Tort law defines intent in a particular way along a spectrum of volition. A person who intends to act in a given way satisfies the intent requirement for many of the intentional torts regardless of whether they intended the harm that their action caused. It's *somewhat* like mens rea in criminal law, with which you may be familiar, in that it's a required mental state that must be proven for any claim in this domain. To make out a claim for an intentional tort, the plaintiff must prove the necessary intent level required for that claim.

In addition, while there is overlap in the kinds of interests that negligence and strict liability protect, the intentional torts protect additional interests that are critically important to the system of tort law. Framing the interests accurately becomes much more important in the intentional torts, which tend to require satisfaction of rigid criteria for a claim to succeed, but which tend to protect interests more broadly than negligence or strict liability do. For instance, the tort of battery does not protect merely against physical harm, the way negligence and strict liability do. This tort protects bodily autonomy, which means that a plaintiff can sue for the invasion of that autonomy even if they've suffered no physical harm.

Similarly, the tort of trespass to land protects against something more than just harm to land; it protects against one's ownership in the land and right to use it. A plaintiff can sue for trespass even if nothing happens to harm their land, merely because property ownership allows owners to stop people from coming onto their land without permission. The interest tort law is protecting runs deep and reflects normative judgment about what society values and believes.

For that reason, tort law's protection of one's bodily autonomy and one's home or property may make intuitive sense. Yet tort law is somewhat idiosyncratic about what it chooses to protect. It has historically been less protection of violations connected with feelings or one's mental state. For most of the history of American tort law, plaintiffs couldn't recover for emotional distress alone. Courts feared fraud and expressed concern over their inability to measure genuine harm or suffering with nothing more than a plaintiff's allegations of distress. As modern psychology made such assessments more reliable and standardized, courts were nonetheless somewhat slow to relax the limitations on recovery for emotional distress.

Scholars have noted the ways in which this sometimes reflected gendered and racist ideas, and tort law continues to need to understand and account for its internal coherence and equity. For one thing, when claims for "fright" or emotional distress succeeded, historically they were usually brought by men on behalf of women (such as a husband or father); for another, they were usually attributable to some other doctrinal justification. One of the cases in this unit, *Gulf v. Luther*, permits recovery by a white

woman for allegedly suffering emotional distress and fright while waiting in a train station when a Black woman employed by the railway company spoke to her in a way deemed to be insulting. There are doctrines you'll see in the case, however, that provide additional reasons for why the court might have permitted recovery despite the general rules limiting recovery for purely emotional distress. Racism and sexist tropes also play a role in the way the legal opinion proceeds and in how it construes the precedents on which it relies.

To understand tort law, it is important to observe the rhetoric used, the way that the court deals with the evidence in the case, and its unacceptable and dehumanizing treatment of the Black woman whose action is the source of the grievance. Following that, we'll look at a case cited in *Luther* which demonstrates how case law entrenches racism and creates silences, systematic gaps in the record that minimize or erase the suffering of people of color and marginalized groups. None of this is comfortable to read about and it may be hard to confront. Facing these problematic legal practices is critical to understanding how the law operates as well as gaining glimpses of how to do better in listening to and amplifying marginalized voices. Even in many cases in which people of color win, often the judge, or the other parties are permitted greater voice and representation and the victorious plaintiff may be somehow silenced or almost absent, as is the case in *Mulloy v. Hop Sang*, the Canadian case featuring an unwanted amputation.

These cases are also meant to give you a sense of how sometimes tort law *did* redress some forms of social injustice; maybe not fully enough, maybe not always, but at least in some instances. In some instances, tort law can operate as a form of civil rights protection, as in *Ruiz v. Bertolotti* in which the court struggles to fit the fact pattern into its existing torts and yet decides not to ignore the defendant's wrongful behavior despite the technical hurdles it must overcome to do so.

Finally, the last case in this Module, *Cobbs v. Grant*, provides a fact pattern that allows you to revisit negligence and test your high-level understanding of the distinctions between negligence and the intentional torts, framed against the backdrop of a medical malpractice fact pattern. It also reaffirms how the interests in battery extend well beyond the scope of a broken bone or bruise to protect a deep and robust form of patient autonomy.

Over the course of the next few classes, we will encounter sometimes painful or triggering material pertaining to race and gender, but it is material that helps us understand the scope of tort law's reach, historically, and currently. It also helps us understand what tort law has avoided doing, and silences tort law has created by defining the suffering in society to count, or not to count, as cognizable under its doctrines

A note about the anachronism of reading older cases: these cases remain relevant for today's learning but reading them requires that we adopt some respectful norms of discourse. Older cases use terms that are out of date and sometimes downright offensive. Your class may develop ground rules for how to discuss sensitive issues, or address class norms in the syllabus. These suggestions offer an alternative, but please follow your course's conventions if those are explicitly provided.

If you are reading from an opinion, you may quote the case language verbatim if you need to do so. Some students may feel that doing so is always unnecessary or triggering, but law school requires that students learn to summarize and paraphrase accurately and, in some cases, verbatim quotation is the most accurate, efficient or even least harmful means of proceeding. Other students may feel that if it's in the opinion, it is language that can be used with impunity and may not realize the full impact of using the terms somewhat carelessly. In addition to these contrasting views, Professors may also wish to meet their pedagogical goals and hold a stimulating conversation without sacrificing an entire class only to the problems of controversial terminology. Your professor will decide how much attention to give this issue, of course, and whether to set ground rules for class discussions. Unless otherwise instructed or collectively determined, I encourage you to adopt the following practices:

- If you are paraphrasing or describing the case, do not use the offensive term; use appropriate 21st-century terms instead. For example, in the Texas cases below, instead of using the terms it uses ("colored" and "Negro woman"), please use the appropriate contemporary term ("African American" or "Black") unless you are reading the exact language of the case. Even then, please be thoughtful about whether and when hateful or offensive language needs to be read aloud. It is painful for many to hear judicial language that encodes and authorizes racism and other forms of discrimination, especially without explicit censure that signals a break with that past.
- Lawyers cannot and should not shrink from the ugliness in our laws whether it is historical or contemporary. Yet as they consider how to increase equity in the legal system, law students should keep in mind that refraining from critiquing racist legal statements or concepts embedded in our laws amounts to ratifying them through silence.

Questions for the Readings

As you read the next few cases, please keep the following questions in mind:

- Why does it matter if an action is brought in negligence versus the intentional torts?
- What interests does each of the domains protect, and what sorts of conduct does each regulate?
- What do you observe about how culpability is defined and determined?
- What do you note about the rhetoric, and judicial voice, in these opinions?

The Tort of Trespass

“A trespasser is a person who enters or remains upon land in the possession of another without a privilege to do so created by the possessor’s consent or otherwise.” Restatement Second of Torts Sec. 329.

For a plaintiff to succeed in bringing a claim of trespass, they will need to prove the following elements:

- unauthorized entry upon land
- with intent

If a person enters the land of another, moving with the required level of intent that entry is a trespass if it was made without permission or beyond the permission granted. The mail carrier has a privilege to enter upon land to deliver and retrieve mail, for instance, but it is a trespass if when they drop off the mail they also pick flowers from the garden or plant seeds for the benefit of the owner. A vacationer who rents a home for a month is permitted there during that time but staying any amount of time past the checkout date triggers the start of a trespass.

In the full Module on the intentional torts, you will learn more about the intent requirement. In brief, if the defendant intended to move and then trespassed through that movement, intent is satisfied. Stating that she lost her way will not help the defendant: the intent required is the intent to move forward in space and to be where one is (even if it is not where one thought that was). Mistake does not invalidate intent because the intent is not directed at knowledge of the land’s boundaries but rather at the volitional movement. Nonvolitional movement does not satisfy the intent requirement. If the defendant was drugged and dropped on someone else’s land or catapulted onto someone else’s land the intent element for trespass is not met. In a certain sense, trespass can be seen as analogous to strict liability in that if a person appears without permission on the land of another, they are technically trespassing, regardless of their fault or intent, so long as they arrived there by their own volition. The next case pushes that notion to its outer limit and synthesizes important principles of intent and causation.

Guille v. Swan, Supreme Court of New York (1822) (19 Johns. 381)

[Editor’s note: please note that the Supreme Court of New York is a trial court, not the highest court in that state. Somewhat confusingly, New York’s highest court is called the Court of Appeals.]

[Rule:] If an act done cause immediate injury, whether it be intentional or not, trespass lies;¹⁰ and if done by the co-operation of several persons, all are trespassers, and all may be sued jointly, or one is liable for the injury done by all; but it must appear that they acted in concert, or that the act of the one sued, ordinarily and naturally, produced the acts of the others.

¹⁰ Editor’s note: “Trespass” here is a reference to an older form of legal action involving a direct injury, and it does not necessarily or only refer to trespass in the ordinary sense with which you are probably familiar, meaning unauthorized entry onto someone else’s land. “Lies” here means “exists as a viable legal action.”

[Application and Holding:] As, where the defendant, *G.*, ascended in a balloon, which descended a short distance from the place of ascent, into the plaintiff's garden; and the defendant, being entangled, and in a perilous situation, called for help, and a crowd of people broke through the fences into the plaintiff's garden, and beat and trod down his vegetables and flowers: *Held*, that though ascending in a balloon was not an unlawful act; yet, as the defendant's descent under the circumstances, would ordinarily and naturally draw the crowd into the garden, either from a desire to assist him, or to gratify a curiosity which he had excited, he was answerable in trespass for all the damage done to the garden of the plaintiff.

In error, on *certiorari*, to the Justices' Court in the city of *New-York*. *Swan* sued *Guille* in the Justices' Court, in an action of trespass, for entering his close,¹¹ and treading down his roots and vegetables, &c. in a garden in the city of *New-York*. The facts were, that *Guille* ascended in a balloon in the vicinity of *Swan's* garden, and descended into his garden. When he descended, his body was hanging out of the car of the balloon in a very perilous situation, and he called to a person at work in *Swan's* field, to help him, in a voice audible to the pursuing crowd. After the balloon descended, it dragged along over potatoes and radishes, about thirty feet, when *Guille* was taken out. The balloon was carried to a barn at the farther end of the premises. When the balloon descended, more than two hundred persons broke into *Swan's* garden through the fences, and came on his premises, beating down his vegetables and flowers. The damage done by *Guille*, with his balloon, was about 15 dollars, but the crowd did much more. The plaintiff's damages, in all, amounted to 90 dollars. It was contended before the Justice, that *Guille* was answerable only for the damage done by himself, and not for the damage done by the crowd. The Justice was of the opinion, and so instructed the jury, that the defendant was answerable for all the damages done to the plaintiff. The jury, accordingly, found a verdict for him, for 90 dollars, on which the judgment was given, and for costs.

SPENCER, Ch. J., delivered the opinion of the Court.

The counsel for the plaintiff in error [Editor's note: this is now the defendant, *Guille*] supposes, that the injury committed by his client was involuntary, and that done by the crowd was voluntary, and that, therefore, there was *382 no union of intent; and that upon the same principle which would render *Guille* answerable for the acts of the crowd, in treading down and destroying the vegetables and flowers of *S.*, he would be responsible for a battery, or a murder committed on the owner of the premises.

The intent with which an act is done, is by no means the test of the liability of a party to an action of trespass. If the act cause the immediate injury, whether it was intentional, or unintentional, trespass is the proper action to redress the wrong. It was so decided, upon a review of all the cases, in *Percival v. Hickey*. (18 *Johns. Rep.* 257.) Where an immediate act is done by the co-operation, or the joint act of several persons, they are all trespassers, and may be sued jointly or severally; and any one of them is liable for the injury done by all. To render one man liable in trespass for the acts of others, it must appear, either that they acted in concert, or that the act of the individual sought to be charged, ordinarily and naturally, produced the acts of the others.

The case of *Scott v. Shepard*, (2 *Black. Rep.* 892) is a strong instance of the responsibility of an individual who was the first, though not the immediate, agent in producing an injury. *Shepard* threw a

¹¹ Editor's note: This now is a reference to trespass in the ordinary sense of unauthorized entry on someone else's land, which the law calls a "close." 87 C.J.S. TRESPASS § 66. Here, the "close" is a reference to the property owned by the plaintiff, *Swan*.

lighted squib, composed of gunpowder, into a market house, where a large concourse of people were assembled; it fell on the standing of *Y.*, and to prevent injury, it was thrown off his standing, across the market, when it fell on another standing; from thence, to save the goods of the owner, it was thrown to another part of the market house, and in so throwing it, it struck the plaintiff in the face, and, bursting, put out one of his eyes. It was decided, by the opinions of three Judges against one, that *Shepard* was answerable in an action of trespass, and assault and battery. *De Grey*, Ch. J., held, that throwing the squib was an unlawful act, and that whatever mischief followed, the person throwing it was the author of the mischief. All that was done subsequent to the original throwing, was a continuation of the first force and first act. Any innocent person removing the danger from himself was justifiable; the blame lights upon the first thrower; the new direction and new force, flow out of the first force. He laid it down as a principle, *383 that every one who does an unlawful act, is considered as the doer of all that follows. A person breaking a horse in *Lincolns-Inn-Fields*, hurt a man, and it was held, that trespass would lie. In *Leame v. Bray*, (3 *East Rep.* 595,) Lord *Ellenborough* said, if I put in motion a dangerous thing, as if I let loose a dangerous animal, and leave to hazard what may happen, and mischief ensue, I am answerable in trespass; and if one (he says) put an animal or carriage in motion, which causes an immediate injury to another, he is the actor, the *causa causans*.¹²

I will not say that ascending in a balloon is an unlawful act, for it is not so; but, it is certain, that the *æronaut* has no control over its motion horizontally; he is at the sport of the winds, and is to descend when and how he can; his reaching the earth is a matter of hazard. He did descend on the premises of the plaintiff below, at a short distance from the place where he ascended. Now, if his descent, under such circumstances, would, ordinarily and naturally, draw a crowd of people about him, either from curiosity, or for the purpose of rescuing him from a perilous situation; all this he ought to have foreseen, and must be responsible for. Whether the crowd heard him call for help or not, is immaterial; he had put himself in a situation to invite help, and they rushed forward, impelled, perhaps, by the double motive of rendering aid, and gratifying a curiosity which he had excited. Can it be doubted, that if the plaintiff in error had beckoned to the crowd to come to his assistance, that he would be liable for their trespass in entering the enclosure? I think not. In that case, they would have been co-trespassers, and we must consider the situation in which he placed himself, voluntarily and designedly, as equivalent to a direct request to the crowd to follow him. In the present case, he did call for help, and may have been heard by the crowd; he is, therefore, undoubtedly, liable for all the injury sustained.

Judgment affirmed.

Note 1. This is an action formally brought in trespass rather than negligence or strict liability partly because in 1822, American tort law was still in its infancy and trespass provided a direct means to analyze the invaded interests. However, under the later-published Restatement (Second) of Torts §§ 519 (applying strict liability to ultrahazardous activities) and 520 (defining ultra-hazardous activities), flying an air balloon would now require imposition of strict liability. Indeed, in the comments to Section 520, aviation is provided as a quintessential example though, as the following dicta make clear,

¹² A Black's Law Dictionary—or Google—will help you cut through the Latin terms you'll encounter in law school. If an unfamiliar term doesn't obstruct your understanding, you might just keep reading without looking it up, and only look it up after you've read the case so that it doesn't break your flow. However, I would strongly encourage you to look up a Latin phrase (or other term) if you're still not sure what it means after reading the case. Here, "causa causans" means the primary or originating cause, the cause of the things (or even the causes) that follows that first cause. It's used to trace damages back to an original source of liability.

that could always change depending on the calculus of risk and available precautions involved in the activity:

[Aviation in its present state of development is ultrahazardous because the best constructed and maintained aeroplane is so incapable of complete control that flying creates a risk that the plane even though carefully constructed, maintained and operated, may crash to the injury of persons, structures and chattels on the land over which the flight is made' (emphasis supplied). And in comment 'g' a distinction is made between airplanes and automobiles, upon the ground that 'the use of automobiles has become so common to the great mass of inhabitants of the United States and the residuum of risk which cannot be eliminated by careful driving and maintenance is so small that the driving of ordinary types of automobiles is not regarded as ultra-hazardous. On the other hand, aviation has not as yet become either a common or essential means of transportation. This, coupled with the fact that as yet aeroplanes have not been so perfected as to make them subject to a certainty of control approximating that of which automobiles are capable, and with the serious character of harm which an aeroplane out of control is likely to do to persons, structures or chattels on the land over which it flies make it proper to regard aviation as an ultra-hazardous activity.'") *Wood v. United Air Lines, Inc.*, 223 N.Y.S.2d 692, 696–97 (Sup. Ct. 1961), *aff'd sub nom. Wood v. United Air Lines*, 226 N.Y.S.2d 1022 (1962)

Note 2. Commentators and later cases often treat the case as having decided the trespass under strict liability. Do you see why, based on the court's legal reasoning?

Note 3. The defendant tries to distinguish the defendant's conduct as "involuntary" and the crowd's as "voluntary," but the court rejects this. How and why?

Note 4. Do you think the balloonist knew, or should have known this was an outcome that was possible? Or even likely? How might it affect your thinking one way or another?

Check Your Understanding (1-7)

Question 1. True or False: *Guille* would likely have been decided differently if *Guille* had not asked a man in Swan’s field for help.

An interactive H5P element has been excluded from this version of the text. You can view it online here: <https://saidtorts2d.lawbooks.cali.org/?p=32#h5p-14>

Question 2. Why did the court draw the comparison between *Guille*’s facts and the facts in *Shepard*, described in the passage below? Select an answer that best captures the function served by the court’s use of this precedent.

“Shepard threw a lighted squib, composed of gunpowder, into a market house, where a large concourse of people were assembled; it fell on the standing of Y., and to prevent injury, it was thrown off his standing, across the market, when it fell on another standing; from thence, to save the goods of the owner, it was thrown to another part of the market house, and in so throwing it, it struck the plaintiff in the face, and, bursting, put out one of his eyes.”

An interactive H5P element has been excluded from this version of the text. You can view it online here: <https://saidtorts2d.lawbooks.cali.org/?p=32#h5p-15>

Question 3. A homeowner has a leaky hot water heater and calls an emergency plumber to see whether her hot water tank needs replacing. When the plumber arrives, the homeowner shows the plumber to the water heater, which is located in the garage, and says “Please do whatever you need to do to test, and if necessary, replace the water heater; don’t worry about the cost. I will be in the room across the hall, taking a phone call for work. If you truly need me, please knock on the door and I can answer any questions you have. I’ll be back out in a couple of hours to check on your progress.”

Which of the following is the likeliest to be a technical trespass:

An interactive H5P element has been excluded from this version of the text. You can view it online here: <https://saidtorts2d.lawbooks.cali.org/?p=32#h5p-16>

The Tort of Battery

For a plaintiff to succeed in bringing a claim of battery, they will need to prove the following elements:

- unauthorized bodily contact by the defendant, which is
- harmful or offensive in nature, and
- made with intent by the defendant.

Battery is the most significant intentional tort in terms of protecting individual rights to bodily autonomy and freedom from invasions and harms by others. The quintessential element in a civil battery is that it violated the victim's consent either by being **entirely unauthorized** or **by exceeding the scope of the consent** the victim granted the tortfeasor. The conduct doesn't have to be "harmful" in the sense of leaving bruises or scars; it may be harmful in other ways because it is traumatizing, or precisely because the physical harms are not as readily discernible.

Note that battery does not necessarily require physical harm: the tort does not protect only against harm to the body; it protects the person's right to decide what can be done to their body. And it doesn't protect against accidental bumps or jostles in the ordinary course of moving around in today's often crowded world. But it does provide protection for a person's physical autonomy, which is a broader interest than mere protection against bruises or broken bones.

Tortious contact may also qualify as "offensive." While there is undeniably a subjective element here, a plaintiff cannot simply claim any contact at all was offensive; there are some settled cases as well as state laws that tend to define what makes the contact offensive, such as by stating that the contact was done without authorization *and* with anger or rudeness. Where there is no lasting or discernible harm so as to make the contact "harmful" but it is provably "offensive," a court may order "nominal damages." These are damages in name only, or damages not designed to compensate monetarily but instead to provide an official recognition of the invasion of the plaintiff's bodily autonomy and to deter future wrongdoing. While one could argue that nominal damages are not worth the costs of litigation, they remain an important way of signaling the boundaries of duties and rights between parties. Sometimes nominal damages may be accompanied by payment of legal fees to the winning party, which can make a significant difference.

The following hypothetical provides an illustration.

Hypothetical: Wrong Ear Surgery Problem

In the early 1900s, an experienced and reputable ear doctor saw a woman complaining of a problem in her right ear. As is customary, he examined both ears. He couldn't make a full diagnosis of the left ear ("owing to foreign substances therein." Consider yourselves warned: tort law will often feel a little TMI). The right ear revealed that there was a perforation in the lower portion of the drum membrane and a large polyp in the middle ear which indicated that some bones of the middle ear were probably diseased. The patient was nervous about undergoing general anesthesia, which remains risky even

today but was riskier still at that time. After consulting with her family doctor, who agreed to be in the room during the surgery, and after several other consultations with the surgeon who would repair her right ear, she agreed to go forward with the surgery. During the surgery, when he could get a better look at it, the surgeon discovered that the right ear wasn't in need of the surgery, but the left ear was. The surgeon showed the family doctor, who agreed with this assessment, and then the surgeon went ahead and performed skillful surgery on the left ear. After the surgery, the patient was upset to learn that the surgery had not been done as scheduled on her right ear, and had happened instead on her left ear, which had not been described to her as diseased in any way before that. She complained of new pain and hearing problems apparently not present before the surgery, or at least not serious enough for her to bring them to her doctor then. She sued for battery, but not medical malpractice.

Practice applying the elements of battery (listed above). Can you see why there is a battery here?

Note 1. This hypothetical fact pattern was based on a classic torts case that is still the leading case nationally on consent to unauthorized operations. *Mohr v. Williams*, 95 Minn. 261 (Minn. 1905). The court ruled in *Mohr's* favor, finding a battery and awarding *Mohr* \$14,322.50, a huge sum in that era. The surgeon successfully appealed the damages award, and the new trial produced the considerably lower award of \$39 for the plaintiff. (The opinion was later overruled on a narrow issue pertaining to damages in *Genzel v. Halvorson*, 248 Minn. 527 (1957).)

Note 2. Ms. *Mohr's* original damages award, of \$14,322.50 would equal \$417,295.80 in today's currency, using a basic tool to account for inflation.¹³ Similarly, \$39 in U.S. dollars from 1905, when *Mohr* was decided, is roughly equivalent to \$1,136.29 in 2020 U.S. dollars. When adding the expenses of hiring counsel to bring not just one, but two lawsuits, including an appeal of the first, does this seem like a fair outcome? Recall that the court found there was a battery "on the merits" (on the legal question at issue), but also that there did not appear to be any errors or lack of skill by the surgeon.

Note 3. *Mohr's* reasoning, included below, helps demonstrate the interests protected by the tort of battery. The court emphasized the law's commitment to a patient's right to bodily autonomy, including making medical decisions for themselves:

This particular question is new in this state. At least, no case has been called to our attention wherein it has been discussed or decided, and very few cases are cited from other courts. We have given it very deliberate consideration, and are unable to concur with counsel for defendant in their contention that the consent of plaintiff was unnecessary. The evidence tends to show that, upon the first examination of plaintiff, defendant pronounced the left ear in good condition, and that, at the time plaintiff repaired to the hospital to submit to the operation on her right ear, she was under the impression that no difficulty existed as to the left. In fact, she testified that she had not previously experienced any trouble with that organ. It cannot be doubted that ordinarily the patient must be consulted, and his consent given, before a physician may operate upon him.

It was said in the case of *Pratt v. Davis*...: 'Under a free government, at least, the free citizen's first and greatest right, which underlies all others—the right to the

¹³ <https://www.officialdata.org/us/inflation/1905?amount=14322.50> Using a more complicated set of inputs, it could be considered \$2,690,000 in relative income using 2019's currency.

inviolability of his person; in other words, the right to himself—... necessarily forbids a physician or surgeon, however skillful or eminent, who has been asked to examine, diagnose, advise, and prescribe (which are at least necessary first steps in treatment and care), to violate, without permission, the bodily integrity of his patient by a major or capital operation, placing him under an anaesthetic for that purpose, and operating upon him without his consent or knowledge.’

1 Kinkead on Torts, § 375, states the general rule on this subject as follows: ‘The patient must be the final arbiter as to whether he will take his chances with the operation, or take his chances of living without it. Such is the natural right of the individual, which the law recognizes as a legal one, Consent, therefore, of an individual, must be either expressly or impliedly given before a surgeon may have the right to operate.’

There is logic in the principle thus stated, for, in all other trades, professions, or occupations, contracts are entered into by the mutual agreement of the interested parties, and are required to be performed in accordance with their letter and spirit. No reason occurs to us why the same rule should not apply between physician and patient. If the physician advises his patient to submit to a particular operation, and the patient weighs the dangers and risks incident to its performance, and finally consents, he thereby, in effect, enters into a contract authorizing his physician to operate to the extent of the consent given, but no further. It is not, however, contended by defendant that under ordinary circumstances consent is unnecessary, but that, under the particular circumstances of this case, consent was implied; that it was an emergency case, such as to authorize the operation without express consent or permission.

The medical profession has made signal progress in solving the problems of health and disease, and they may justly point with pride to the advancements made in supplementing nature and correcting deformities, and relieving pain and suffering. The physician impliedly contracts that he possesses, and will exercise in the treatment of patients, skill and learning, and that he will exercise reasonable care and exert his best judgment to bring about favorable results. The methods of treatment are committed almost exclusively to his judgment, but we are aware of no rule or principle of law which would extend to him free license respecting surgical operations. Reasonable latitude must, however, be allowed the physician in a particular case; and we would not lay down any rule which would unreasonably interfere with the exercise of his discretion, or prevent him from taking such measures as his judgment dictated for the welfare of the patient in a case of emergency.

Note 4. Ms. Mohr continued to complain of pain in her left ear. Should tort law be the source of her remedy, and if so, why? What does your answer depend on?

Note 5. What sorts of additional facts do you think might have made it reasonable for Dr. Williams to operate on Ms. Mohr’s left ear, even without her consent?

Note 6. Do you see why this is not a medical malpractice case?

Note 7. What do you imagine are the consequences of a ruling like this, in terms of physician behavior and the practices adopted by institutions such as hospitals?

Check Your Understanding (1-8)

Question 1. True or false: Trespass and battery are both intentional torts which require plaintiffs to show harm.

An interactive H5P element has been excluded from this version of the text. You can view it online here: <https://saidtorts2d.lawbooks.cali.org/?p=32#h5p-17>

Question 2. True or false: Trespass and battery are both intentional torts which can attach to behavior even when the plaintiff provided consent, if the conduct ultimately exceeds the scope of the plaintiff's consent.

An interactive H5P element has been excluded from this version of the text. You can view it online here: <https://saidtorts2d.lawbooks.cali.org/?p=32#h5p-18>

Mulloy v. Sang, Alberta Supreme Court, Appellate Division (1935) (1 W.W.R. 714)

The plaintiff's claim is for professional fees for an operation involving the amputation of the defendant's hand which was badly injured in a motor-car accident. The accident took place near the town of Cardston and the defendant was taken to the hospital there. The plaintiff, a physician and surgeon duly qualified to practice, was called to the hospital and the defendant, being a stranger and unacquainted with the plaintiff, asked him to fix up his hand but not to cut it off as he wanted to have it looked after in Lethbridge, his home city. Later on in the operating room the defendant repeated his request that he did not want his hand cut off. The doctor, being more concerned in relieving the suffering of the patient, replied that he would be governed by the conditions found when the anaesthetic had been administered. The defendant said nothing. As the hand was covered by an old piece of cloth and it was necessary to administer an anaesthetic before doing anything, the doctor was not in a position to advise what should be done. On examination he decided an operation was necessary and the hand was amputated.

Dr. Mulloy said the wounds indicated an operation as the condition of the hand was such that delay would mean blood poisoning with no possibility of saving it. In this he was supported by the two other attending physicians. I am, however, not satisfied that the defendant could not have been rushed to Lethbridge where he evidently wished to consult with a physician whom he knew and relied on. Dr.

Mulloy took it for granted when the defendant, a Chinaman without much education in English and probably not of any more than average mentality, did not reply or make any objection to his statement that he would be governed by conditions as he found them, that he had full power to go ahead and perform an operation if found necessary. On the other hand, the defendant did not, in my opinion, understand what the doctor meant, and he would most likely have refused to allow the operation if he did. Further, he did not consider it necessary to reply as he had already given explicit instructions.

Under these circumstances I think the plaintiff should have made full explanation and should have endeavoured to get the defendant to consent to an operation, if necessary. It might have been different if the defendant had submitted himself generally to the doctor and had pleaded with him not to perform an operation and the doctor found it necessary to do so afterwards. The defendant's instructions were precedent and went to the root of the employment. The plaintiff did not do the work he was hired to do and must, in my opinion, fail in his action.

The defendant has counterclaimed for damages in the sum of \$400, being \$150 for an artificial hand and the balance for loss of wages due to the operation and possibly general damages.

In my opinion the operation was necessary and performed in a highly satisfactory manner. Indeed, there was no suggestion otherwise. The damage and loss and the cost of an artificial hand are the results of the accident and not the unauthorized operation. The defendant, however, is, in my opinion, entitled to damages because of the trespass to the person, which at the same time became trespass *ab initio*, having in mind the old case of *The Six Carpenters* (1610) 8 Co. Rep. 146a, 77 E.R. 695. The damages are *per se* and should be more than nominal. Personally, I in a similar position might have been able to satisfy myself that the operation was necessary, and that I should be glad to pay the reasonable fee charged, but it was not my hand and the defendant will always no doubt feel that he might have saved the hand if he had consulted with a doctor he knew. While I might have been able to forego my rights, I cannot ask the defendant to do so and he is entitled to rely on his rights. There also must have been some shock to him when he found out his hand had been taken off in the manner in which it was, over and above the ordinary shock from an operation. His damages, should, therefore, be substantial but only sufficient to make them substantial rather than nominal. I place the amount at \$50.

The action is dismissed with costs and the defendant is entitled to his costs of the counterclaim.

Note 1. Using the same inflation calculator and basic assumptions, the \$50 Hop Sang was awarded for his wrongfully removed hand in 1822 produces a value of roughly \$921.62 in today's Canadian dollars.¹⁴ Even if we assumed Sang had been awarded \$10,000 in today's Canadian dollars, do you think that would provide adequate compensation for the injury? Why or why not? Is there a number at which your answer changes?

Note 2. The judicial voice speaks for Sang at several points, imagining what the plaintiff might have thought or felt and distinguishing his own views ("Personally, I in a similar position... but it was not my hand"; "While I might have been able to forego my rights, I cannot ask the defendant to do so"). Why do you think he does not cite to the plaintiff's own testimony on these issues? What other observations do you have about the way the court describes both the plaintiff's views and his own about the surgery?

¹⁴ <https://www.officialdata.org/canada/inflation/1935?amount=50>

Exam Tip: In the case of both trespass and battery, often the conduct in question qualifies as a violation because it exceeds the scope of consent. For instance, at the end of a dinner party, a guest leaves, but secretly sits in the driveway, just out of sight of the hosts, to sober up before driving. Technically, the social event has ended, and their permission to remain on the host's land is unclear. Or to take another example, a romantic partner usually allows their partner to hold their hand all the way through the movie but doesn't want to this time. The attempt to withdraw the hand signals that consent is withdrawn and a second attempt to shake free of the grip, when their partner is still holding onto their hand, makes that desire clear: any remaining contact from that point is technically a battery. Sometimes such instances may be called **technical trespass** or a **technical battery**, for which, as noted above, the damages may be nominal or minimal (depending on the precise facts). But the *liability* will still attach even if the *damages* are low or non-existent.

Part II. Protecting the Mind: Assault and Emotional Harms

The Tort of Assault

Like the tort of battery, the tort of assault must be kept distinct from its criminal counterpart. In the civil context, to bringing a successful claim of assault, the plaintiff will need to prove the following elements:

- an act, or threat of an action
- done with intent, that
- creates in the plaintiff a reasonable apprehension of
- imminent bodily harm

The scope of the tort has been critiqued for what it recognizes and excludes. The tort was intended to be construed narrowly, a true protection against harm almost immediately upon the victim, and thus many threats that promise harm in the future fall outside the scope of the tort by failing the imminence requirement. Later in the course, you will learn about the prospect of recovering for emotional damages or distress suffered without accompanying physical injuries. For now, the focus is on “fright” or more precisely, on awareness of harm that is imminent and reasonably perceived, not merely imagined.

A Note on Terminology: “Objective” versus “Subjective.” When the law uses the word “reasonable,” it is signaling its use of an *objective* standard. The legal meanings of “objective” and “subjective” differ from the lay meanings. Ordinarily, subjective means “influenced by personal feelings or tastes; emotional or intuitive.” Objective means *not* influenced by personal feelings or tastes; impersonal; fact-based; unbiased; nonpartisan; disinterested or even scientific. In law, however, subjective means particularized to the person in question; objective means abstracted to a generalized level: what would the *reasonable person* have felt or done under such circumstances, rather than what the *plaintiff himself actually felt or did*. This distinction between objective and subjective states of mind or assessments of conduct will grow in importance throughout your study of tort law. **For instance, the intent standard for the intentional torts is subjective:** we care what *this particular defendant* thought or knew when they acted. **In assault, the apprehension of imminent bodily harm**

is objective: would an ordinary reasonable person have been placed in apprehension of harm? This allows tort law to exclude from protection someone overly sensitive who would qualify under a subjective standard (tailored to that individual) but who cannot recover if reasonable people would not share the apprehension under those circumstances.

Most significantly of all, **negligence is determined using an objective standard:** it uses a general measure based on classes of people (physicians, blind people, adults, elderly or very young people) rather than a particular defendant: what would a *reasonable person have done under the circumstances*, not *what did this defendant believe was reasonable to do under the circumstances*? Negligence broadens its scope of liability by asking not just what the plaintiff knew or did but what the reasonable person *would have known* or *would have done*. In some instances, a given tort or rule will incorporate both perspectives. For example, in battery, the perspective for whether contact is offensive is first objective: would the *reasonable plaintiff* find the contact offensive, not whether *this plaintiff did*? Once that hurdle is cleared, it is also necessary to determine whether the plaintiff did in fact find it offensive. Contact must be objectively considered offensive, at a minimum *as well as subjectively, by this plaintiff, considered offensive*. The rationale is straightforward: if you're insensitive and didn't mind the contact but know others would find it offensive, tort law does not permit you to receive a windfall by suing for something you happened not to mind. Most students find the objective/subjective distinction confusing at first but eventually manageable, partly because it's a concept they will see over and over in torts and in other classes in their first year and beyond.

Questions for the Readings

As you read the next few cases, please keep the following questions in mind:

- What interests is tort law seeking to protect? Against what sorts of harms or invasions, and by whom or what? Note where you see courts describing the interests they are protecting (or declining to protect) and put in your own words how the court justifies its decision.
- What sorts of limits can you identify in the law's protection of these interests? How does—and how should—the law draw these limits? Why are such limits necessary?
- In what ways do these legal rulings illustrate, entrench or subvert power dynamics or social status in our society? In what ways could they be amended to create new possibilities?
- If you do not see either entrenchment or possibilities for change, would any of the cases read differently for you if the age/gender/race/ability/sexual orientation/general identity of one or more of the parties changed? Would the situation strike you as different if a corporation, instead of an individual, were one of the parties?

Background Tort Doctrines: The Common Carrier Doctrine and Vicarious Liability

Two legal doctrines will be helpful to your reading of the next case, *Gulf, Colorado & Santa Fe Railway Co. v. Luther*.

First, the “common carrier” doctrine historically applied to companies engaged in the transportation of customers from place to place for compensation (such as public railroads, bus lines, taxi companies, airlines, cruise ship lines, or other similar entities). Tort law has traditionally imposed a higher standard of care on common carriers in order to protect consumers, though this has varied by state and been eroded somewhat over time. In New York, for instance, there is no longer a heightened duty; common carriers owe the same duty of “reasonable care” as any other possible tortfeasors. But in the era before meaningful consumer protection laws arose in the first decades of the twentieth century, this heightened duty was an important means of ensuring passengers’ safety and comfort.

Second, under the “vicarious liability” doctrine, an employer is responsible for the tortious conduct of their employees while the employees are working “within the scope of their employment.”

This generally means that employers are liable for their employees while employees are engaged in work-related acts and efforts during work (and thus excludes bad behavior or carelessness outside of work or actuated by personal rather than professional motivations). Vicarious liability is a very important doctrine that you will see again several times in this course, especially with respect to negligence and how to consider the effects of potentially having multiple parties at fault. It is also significant in a number of upper-division courses, so it’s spending time dividing a bit more deeply into its origins, purposes and scope before proceeding.

Introduction to Vicarious Liability

Vicarious liability allows victims of tortious conduct to recover against the employer for the conduct by their employee under certain circumstances. The ability to pursue a case against the employer—who is almost always the party with the “deepest pockets” or greatest capacity to remunerate the plaintiff for their losses—is often of profound benefit to the victim. As this doctrine was developing in 18th-century England, jurists labeled it with the Latin phrase, “*respondeat superior*,” roughly meaning “let the person in the position of higher power respond” for the wrongdoing of the person in their employment or supervision. The terms used to characterize labor relations were “master” and “servant,” rather than the more modern employer and employee or principal and agent.¹⁵

Vicarious liability can be taught at many different points in an introduction to tort law, because it plays a role in so many cases, and it is not limited to one kind of tort. One way to understand its effect, however, is to consider it a form of strict liability: the employer is *not necessarily at fault* but under the doctrine, liability is allocated to the employer anyway, by virtue of the relationship between employer and employee. Note that it is often possible for an employer *also* to be separately at fault: consider the following scenario.

Pizza Delivery Hypothetical. A delivery driver is the employee of a restaurant and drives negligently—under the influence of hallucinogenic drugs—while delivering one of their pizzas. When the driver causes a car accident that injures someone, the employer would ordinarily

¹⁵ The underlying legal reasoning for the doctrine is illustrated in this case: “If the servants of A with his cart run against another cart, wherein is a pipe of wine, and overturn the cart and spoil the wine, an action lieth against A. So where a carter’s servant runs his cart over a boy, action lies against the master for the damage done by this negligence: and so it is if a smith’s man pricks a horse in shoeing, the master is liable. For whoever employs another, is answerable for him, and undertakes for his care to all that make use of him. The act of a servant is the act of his master, where he acts by authority of the master.” *Jones v Hart*, 90 E.R. 1255 (Court of King’s Bench) 1703.

be **vicariously liable for the victim's injuries** because the driver is an **employee** acting in the **scope of employment**. This would be the case even if the restaurant (or its owners) displayed no fault with respect to the accident. (In this scenario, we are assuming that the employer isn't driving or present or directly involved.) Tort law allocates **vicarious liability** to the employer for their employees' actions so long as the employee's actions occur within the scope of employment. To prevail on this claim, a plaintiff would need to prove: 1) that the driver *was* an employee (as opposed to an independent contractor or a driver who made unauthorized use of a company vehicle, such as a thief); and 2) that the accident happened during the scope of employment (that is, not outside work or after work, such as during a lunch break or commuting to and from home, even if driving a corporate vehicle) and 3) that there was negligence on the part of the employee, that is, that the employee had a duty of reasonable care that they breached, thus causing the plaintiff's harm. If negligence analysis fails on some element with respect to the employee's conduct, the plaintiff will not have a vicarious liability claim against the employer.

However, an **alternate (or additional) theory** of liability might seek to show that **the employer's hiring, training or retention was negligent**. This would not be a vicarious liability claim but a separate claim seeking to prove something else. Perhaps the employer overlooked a prior record of DUI's that a background check could have brought to light (which might constitute **negligent hiring**); or failed to make its rules and policies clear (which could constitute **negligent training and supervision**); or **failed to fire the driver** after the company discovered he routinely had been delivering their product while stoned (which would constitute **negligent retention**). Just because a vicarious liability claim is unavailable does not mean that all is lost for a plaintiff, and conversely, merely establishing that a vicarious liability claim might exist is not dispositive of whether a negligence claim is available against the employer. The two are independent of each other and indeed, as this hypothetical shows, the two kinds of claims focus their inquiries on the behavior of different entities.

The most common examples of vicarious liability in tort law arise in negligence but it is possible for employees to commit intentional torts while serving their employer (such as when a bouncer commits a technical battery by escorting a patron out of a nightclub but accidentally harms the patron, for instance). More commonly, employee conduct that is intentionally tortious falls outside the employer's responsibility. The key, again, is if the **employee is acting within or outside "the scope of employment."** The Restatement (Second) of Agency Sec. 237 lays out the factors to consider in determining whether something falls within the scope of employment (and it uses the old language of the common law, "master" and "servant"):

To be within the scope of employment, an act must be of the sort authorized, done within space and time limits fixed by the employment and accompanied by an intention to perform service for the master. See §§ 233-236. If, having in mind either his master's business and his own, or only his master's business, the servant departs too far from the space or time limits, he no longer acts within the scope of employment.

These principles are widely applied in tort law with respect to employers and their employees as well as "principals" and their "agents," which permits a broader scope of potential liability than if the rule were applicable only to employers and employees. There is an entire Restatement for the law of agency, in fact, because the concept of agency plays a significant role in corporate law, partnership law, and employment among others. Vicarious liability does *not* typically apply to the work of contractors one

hires. Put in the form of a rule: **a hiring party is not vicariously liable for the torts of their independent contractor.**

Exam Tip: A vicarious liability claim **always requires an underlying act of tortious conduct**. If there is no tort (because the elements are not met or because there is a successful defense), then you need not reach the issue of vicarious liability. Vicarious liability is **not a rule that determines liability** based on conduct; **it's a rule that allocates liability** based on a pre-existing determination of liability (if the tests for vicarious liability are met). Always be sure to identify the underlying tort first, and then consider whether vicarious liability will apply to it. Do not forget to ask, additionally or instead, whether the employer is liable on the basis of their own conduct.

The rule that hiring parties are not liable for the torts of their independent contractors has numerous rationales. Unlike employees, independent contractors are generally thought to stand on their own, financially and legally. They are usually entities with their own insurance (“licensed, bonded and insured” may be a phrase you have heard), and they are likely to possess the desire and capacity to control their own processes. Thus, they have the incentives to optimize for caution and efficiency. They are also deemed (presumptively) to possess skill and training in their field. These factors tend to mean that tort law’s purposes are served by fixing liability for their conduct with the independent contractors themselves. However, courts are concerned that parties might attempt to contract so as to characterize their working relations as hiring party/independent contractor, rather than employer/employee, in an attempt to evade liability. In fact, this points to a larger policy concern. When you take business organizations, you will learn that there is an ongoing concern about strategic behavior, such as deliberate undercapitalization to enable parties to claim they are “judgment proof,” or otherwise structuring entities and business practices to evade the liability that tort law’s principles would ordinarily allocate following traditional rules and doctrines. Corporate law has developed many means of trying to forestall this strategic behavior, and courts may “pierce the corporate veil” to look through whatever structures entities are using in their potentially unlawful behavior. Somewhat similarly, in torts cases, courts may “look through” contracts that treat parties as independent contractors if those appear to be suspicious. The Restatement of Agency provides guidance on how to assess hiring relationships and when to determine that there is, in fact, an employer/employee relationship, whatever the parties might have attempted to create. It does so, in part, by defining the relationship in terms of actual control or the right to control.

Scope of Employment—Restatement (Second) of Agency § 220. Definition Of Servant

(1) A servant is a person employed to perform services in the affairs of another and who with respect to the physical conduct in the performance of the services is subject to the other’s control or right to control.

(2) In determining whether one acting for another is a servant or an independent contractor, the following matters of fact, among others, are considered:

(a) the extent of control which, by the agreement, the master may exercise over the details of the work;

- (b) whether or not the one employed is engaged in a distinct occupation or business;
- (c) the kind of occupation, with reference to whether, in the locality, the work is usually done under the direction of the employer or by a specialist without supervision;
- (d) the skill required in the particular occupation;
- (e) whether the employer or the workman supplies the instrumentalities, tools, and the place of work for the person doing the work;
- (f) the length of time for which the person is employed;
- (g) the method of payment, whether by the time or by the job;
- (h) whether or not the work is a part of the regular business of the employer;
- (i) whether or not the parties believe they are creating the relation of master and servant; and
- (j) whether the principal is or is not in business.

Note: The Restatement (Second) of Agency has been superseded by the Restatement (Third) of Agency, published in 2006. Nonetheless, courts continue to cite to precedents that incorporated the factors from the earlier Restatement, which means that you will continue to encounter case law that reflects some version of these factors. Not all of them are necessarily mentioned in each case (and you should not feel the need to apply all 10 of them on an exam question!) Often, courts pick the ones most salient to apply to the facts at bar. This is a good example of how law school requires you to gain substantive knowledge and also to develop judgment about which things you know are most helpful or relevant in a given moment.

Check Your Understanding (1-9)

Question 1. A motorcyclist, Mo, is injured in a collision by a van driven by Drye. Drye was negligent in his driving and the only one at fault in the accident. Drye delivers newspapers under a contract with The Arizona Herald, a large state-wide news publication.

Which of the following statements below most support Mo's attempt to hold the Herald vicariously liable for Drye's negligent driving?

An interactive H5P element has been excluded from this version of the text. You can view it online here: <https://saidtorts2d.lawbooks.cali.org/?p=32#h5p-19>

Gulf, C. & S.F. Ry. Co. v. Luther, Texas Court of Civil Appeals (1905) (40 Tex.Civ.App. 517)

This suit was brought by appellee to recover damages for an alleged insult to his wife, made by a negro woman while in appellant's employ as a waitress in attendance on the ladies' waiting room in the passenger station of appellant at Ft. Worth, Tex., and for alleged nervous prostration of appellee's wife caused by such insult. The appellant answered by a general denial, and specially that the negro woman was provoked to say what she did by opprobrious epithets addressed to her by appellee's wife. The trial of the cause resulted in a verdict and judgment against the appellant for \$2,500.

Conclusions of Fact.

It is undisputed that appellant owns and operates a line of railroad extending through Hunt county to Ft. Worth, Tex., and another line of road extending from Ft. Worth to Morgan, Bosque county, Tex.; that it is, and was in August, 1903, a common carrier of passengers using said lines of railway for such purpose; that during the month of August of the year aforesaid appellant, in connection with other common carriers of passengers, was in possession, control, and use of a depot building on its roads in Ft. Worth, Tex., for the use and accommodation of its passengers, in which there was a waiting room set aside for the reception of its lady passengers and children;¹⁶ that this room was then entrusted by appellant to a negro woman in its employ, the duties of whose employment were to keep the room clean and in good order for its passengers, attend their wants, and minister to their comfort while awaiting passage on its trains; that in the latter part of June, 1903, the plaintiff, with his wife and four small children, having become passengers over appellant's said lines of road from a station in Hunt county to Morgan, Tex. (the latter station being their destination), arrived at its depot in Ft. Worth about 7 o'clock in the morning for the purpose of taking one of its trains, which was due at 7:50 o'clock that morning; that plaintiff, being informed that the train was late, left his wife and children in the waiting room for women and children which was in charge of the negro woman in appellant's employ charged with the duties aforesaid, and went out into the city to attend some matters of business.

The evidence is reasonably sufficient to prove that during plaintiff's absence from the depot the negro woman, while in the discharge of her duties, became very angry about one of the plaintiff's little children accidentally spilling from a cup some water on the floor, and when informed by the child's mother, plaintiff's wife, the spilling of the water by the child was unintentional, because the child did not know the water was in the cup, the negro woman turned upon Mrs. Luther, and what was said and done had best be told in her language: "When I told the negro woman that the child didn't know the water was in the cup, she turned on me with an angry look, and said, 'The child did know the water was in the cup,' and I told her that the child did not know that the water was in the cup. Then she said to me, 'If you say the child did not know that the water was in the cup you are a liar.' I then said to her, 'I have not been accustomed to be treated this way by colored people.' She then replied: 'I am used to your kind. I meet up with them every day.' During the conversation she was standing right over me, shaking her finger right in my face, and looking vicious and angry. She stood over me about five minutes, and said many things to me that I cannot remember, as I was very much frightened at the

¹⁶ White women and children would wait in this room to be protected from the hustle and bustle of the railroad station, apparently. Here, the husband has deposited his wife and children while he goes back out on the town on some sort of errand as they all await the train. At least in this railroad station, an African-American woman was employed to keep the waiting room clean and orderly.

time.” The negro woman testified differently as to what occurred, but, as the testimony of Mrs. Luther is corroborated by other circumstances, and as the jury from its verdict evidently believed her narration of the occurrence, we find it is true that Mrs. Luther, in consequence of the abuse and ill-treatment by the negro, was greatly frightened, humiliated, worried, and distressed, causing her nervous prostration, physical pain, and mental anguish, to plaintiff’s damage in the amount found by the verdict.

Conclusions of Law.

The first assignment of error¹⁷ complains of the court’s overruling defendant’s amended motion for a new trial, upon the ground that the verdict is contrary to the law and evidence and is excessive, in that it fails to show that the sickness and physical pain suffered by Mrs. Luther were proximately caused by the negligence of defendant. The outrageous conduct and language of the negro woman, whether denominated negligence or not, were, because done by her as appellant’s servant and while in the discharge of the duties of her employment, acts for which the appellant as a common carrier of passengers is responsible and liable to plaintiff for all the damages proximately flowing therefrom. That plaintiff’s wife suffered insult and indignity at the hands of appellant’s servant, and was treated disrespectfully and indecorously by her under such circumstances as to occasion mental suffering, humiliation, wounded pride, and disgrace, there can be little doubt. At least the jury might have so found from the evidence before them. And if it should be conceded that she suffered no physical injury or sickness in consequence, still the appellant would be liable for the consequences of such wrongs done to a passenger.

In considering the duties of carriers to their passengers, Hutchinson on Carriers, §§ 595, 596, states the rule as follows: “The passenger is entitled, not only to every protection which can be used by the carrier for his personal safety, but also to respectful treatment from him and his servants. From the moment the relation commences, as has been seen, the passenger is in a great measure under the protection of the carrier, even from the violent conduct of other passengers, or of strangers. ... The carrier’s obligation is to carry the passenger safely and properly, and to treat him respectfully; and, if he entrusts the performance of this duty to his servants, the law holds him responsible for the manner in which they execute the trust. The law seems to be now well settled that the carrier is obliged to protect his passenger from violence and insult from whatsoever source arising. He is not regarded as an insurer of his passengers’ safety against every possible source of danger, but he is bound to use all such reasonable precaution as human judgment and foresight are capable of to make his passengers’ journey safe and comfortable. He must not only protect his passengers against the violence and insults of strangers and co-passengers, but, a fortiori, against the violence and insults of his own servants. If his duty to the passenger is not performed, if this protection is not furnished, but, on the contrary, the passenger is assaulted and insulted through the negligence or the willful misconduct of the carrier’s servant, the carrier is necessarily responsible. And it seems to us it would be a cause of profound regret if the law were otherwise. The carrier selects his own servants, and can discharge them when he pleases, and it is but reasonable that he should be responsible for the manner in which they execute their trust.”

Thompson on Negligence, § 3186, after stating the above rule, adds: “The carrier is liable absolutely, as an insurer, for the protection of the passenger against assaults and insults of his own servants,

¹⁷ The “assignments of error” mentioned here are the grounds on which the case is being appealed, namely, that the court below made errors that this appellate court should address (in the ways in which the appellant is seeking relief).

because he contracts to carry the passenger safely and give him decent treatment en route. Hence, an unlawful assault or insult to a passenger by his servant is a violation of his contract by the very person whom he has employed to carry it out. The intendment of the law is that he contracts absolutely to protect his passenger against the misconduct of his own servants whom he employs to execute the contract of carriage. The duty of the carrier to protect the passenger during the transit from the assaults and insults of his own servants being a duty of an absolute nature, the usual distinctions which attend the doctrine of respondeat superior cut little figure in the case.”

In *Elliott on Railroads*, § 2579, treating upon this subject, it is said: “It is not merely a question of negligence in such cases, nor is it strictly a question depending upon the scope of the servants’ particular employment. It is a question of the absolute duty of a railroad company to its passengers as long as the relation subsists, and a breach of that duty on its part, whether caused by the willful act of an employe or not. A carrier is bound to discharge the implied duty, arising out of its contract and imposed by law, that its passengers shall be protected from injury by its servants and shall not be willfully insulted and harmed by them; and, if it commits the discharge of this duty to an employe, it may well be held to do so at its peril, notwithstanding the exercise of care on its part in selecting the servants. Either the company or the passenger must take the risk of infirmities of temper, maliciousness, and misconduct of the employes whom the company has placed upon the train and to whom it has committed the discharge of its duty to protect and look after the safety of its passengers. A passenger has no control over them, and the company alone has the power to select and remove them. It is therefore but just to make the company, rather than the passengers, take this risk, and to hold it responsible. This leads to the conclusion that a railroad company is liable for an injury willfully inflicted upon a passenger by an employe while engaged in performing a duty which the carrier owes to the passenger, or in executing the contract, although the company is guilty of no negligence *522 in selecting them and such act was not strictly within the scope of their employment or line of their duty, in the sense that it was done for the carrier or arose out of the performance of their particular duty.” See also, *Traction Co. v. Lane* (Tenn.Sup.) 53 S.W. 558.

This rule is strictly observed in this state. In *Dillingham v. Russell*, 73 Tex. 51, it is said: “The rule,” referring to the principle that the master is not ordinarily liable for an injury resulting from the willful and malicious acts of his agent not done in the course of his employment, “however, cannot be applied in a case in which the master by contract, express or implied, is under obligation to protect the injured person from the servant’s wrongful act as well as his own. Where a duty is thus imposed on the master, for whose acts, whether of omission or commission, resulting in injury to the person entitled to have the duty performed, the master must be held as fully responsible and liable to make at least actual compensation as though the act were his own personal act. In such cases, if the servant does what the master could not suffer to be done without violation of the particular duty resting upon him, or if the servant omits to do that requisite to the full discharge of the master’s incumbent duty, then the master must be held responsible for the servant’s wrongful or malicious act or omission, for otherwise it would result that a master might relieve himself from obligation to perform a duty fixed by contract, or otherwise, by the employment of servants to conduct the business to which the duty attaches. The master’s obligation cannot thus be avoided, and whether the servant’s act violative of the master’s duty be willful or malicious is a matter of no importance in determining the liability and obligation of the master to make actual compensation to the injured person. It has been steadily held to be the duty of carriers of passengers to protect them, in so far as this can be done by the exercise of a high degree of care, from the violence and insults of other passengers and strangers, and to protect them from the

violence and insults of the carrier's own servants, and the inquiry whether this duty arises from contract or from the nature of the employment becomes unimportant, except that the duty goes with the carrier's contract, however made, whereby the relation of carrier and passenger is established." [cc]

The case of *Texas & Pacific Ry. Co. v. Jones* (Tex.Civ.App.) 39 S.W. 124, is one where the plaintiff's wife, who was in defendant's depot for the purpose of taking passage on one of defendant's trains, was insulted by the wife of the ticket agent, but suffered no physical injury in consequence, and the question presented was whether the husband could recover damages for her mental suffering. It was held that it was the duty of appellant's station agent to protect her from insult and abuse from all persons while she was at its station waiting to become a passenger on its train, and she had the right to recover for a breach of such duty whether she received physical injuries or not. In the case of *523 *Houston & Texas Central Ry. Co. v. Perkins* (Tex.Civ.App.) 52 S.W. 124, where the plaintiff and his wife were passengers in a Pullman sleeper attached to one of defendant's trains, and, at night, the defendant permitted drunken men to enter the coach where plaintiff and his wife had retired, allowing the drunkards to remain and use profane and indecent language, which caused the wife mental anguish and loss of rest, this court held, in an opinion by Justice Fly, that the husband was entitled to recover damages though his wife sustained or suffered no physical injuries. See, also, *M., K. & T. Ry. Co. v. Ball* (Tex.Civ.App.) 61 S.W. 327. The case of *I. & G.N. Ry. v. Henderson* (Tex.Civ.App.) 82 S.W. 1065, is one where a negro passenger, with the knowledge of the conductor, was vilified and made to dance for the amusement of the passengers by several drunken rowdies, who had entered the train; and, though the evidence failed to show that he suffered any physical injuries, a verdict against the railway company for \$1,000 damages on account of his humiliation, mortification, and fright was affirmed on appeal. See, also, *Quinn v. L. & N. Ry. Co.* (Ky.) 32 S.W. 742.

We have quoted the foregoing elementary principles and cited cases falling under them for the purpose of demonstrating that the liability of a common carrier for insults by its servants causing humiliation, a sense of disgrace, mental anguish, or fear in a passenger is independent of physical injury or bodily harm; and that such liability does not depend upon the negligence of the master in employing the servant, or the scope of his authority, if the insult is given while employed about his master's business.

It being established by the decisions of this state that mental suffering is an element of damages, where it results from a breach of the carrier's contract or duty, though no physical injury may have been sustained, and, as the evidence in this case shows plaintiff's wife suffered mental anguish from the consequence of such breach, which was also a tort, it was for the jury to determine the quantum of damage. In such a case the law does not undertake to, nor can it, exactly measure his damages, but it authorizes the jury to consider the injured feelings of the party, the indignity endured, the humiliation, wounded pride, mental suffering, and the like, and to allow such sum as it may determine is right. When this is done, unless the verdict is palpably wrong, after it has been approved by the trial court, it is not the province of an appellate tribunal to disturb it.

What could be more humiliating to a frail, delicate, sensitive woman, with a babe at her breast and her other little ones around her, than to be pounced upon, vilified, and traduced by a negro servant in a railway depot, where her relation as passenger to its owner entitles her to be treated with respect and kindness? Is it any wonder to those who can contemplate the effect of such an outrage that the poor woman for months afterwards, as she testified, could not close her eyes without that angry, threatening negro arising before her and murdering sleep? In *G., C. & S.F. Ry. Co. v. Trott*, 86 Tex. 412, the Supreme Court says: "That a physical personal injury may be produced through emotion of the mind

there can be no doubt. The fact that it is more difficult to produce such an injury through the operation of the mind *524 than by direct physical means affords no sufficient grounds for refusing compensation in an action at law, where the injury is intentionally or negligently inflicted. It may be more difficult to prove the connection between the alleged cause of injury, but if it be proved, and the injury be the proximate result of the cause, we cannot say that a recovery should not be had.” It was for the jury to say from the evidence whether plaintiff’s wife, in consequence of the outrage inflicted upon her by appellant’s servant, suffered from nervous prostration and sickness, and there being evidence to support its finding, we deemed it our duty to make our conclusions of fact conform thereto, and, in view of the evidence and the principles of law above enunciated, to conclude that the verdict is not excessive. This disposes of the first and second assignments of error.

[Editor’s note: The third assignment of error is omitted here.]

The fourth assignment complains that the court erred in not sustaining defendant’s objection to that part of the answer of Mrs. Luther *525 to the sixth interrogatory which is as follows: “The little girl May was very much frightened, and said ‘Mamma, let’s get out of here’”—because such part of the answer was immaterial, irrelevant, and hearsay. *** However, we have no doubt that this part of the answer was admissible in evidence as part of the *res gestae*,¹⁸ and for that reason distinguishable from hearsay. For the appearance and exclamation of the child was when the negro was standing over and abusing her mother, and were indicative of the woman’s action and language, and tended to show her violent and outrageous conduct toward plaintiff’s wife. [cc]

The testimony complained of in the fifth, sixth, and seventh assignments was admissible in evidence under the rule that, where the bodily and mental feelings of an individual are material to be proved, the usual expressions of such feelings, made at the time in question, are original evidence. If they are the natural language of the affection, whether of body or mind, they furnish satisfactory evidence, and often the only proof of its existence. And whether they were real or feigned is for the jury to determine. [cc] And a witness may testify that another person seemed to be sick, suffering, nervous, or in good or bad health. [cc]

While the rule, expressed in the court’s charge, that “railway companies are not insurers of the safety and comfort of their passengers, but are required to exercise that high degree of care that very cautious and prudent persons would have exercised under the same or similar circumstances, and a failure to do so is negligence,” may not be strictly applicable to a case of this character, its being given in the charge [to the jury] could not have possibly prejudiced the defendant, since in a case like this the common carrier is absolutely liable for injuries unlawfully and wrongfully inflicted by his servant on a passenger.

There is no error in the judgment, and it is affirmed.

Note 1. What is the tortious harm here?

Note 2. What do you note about how the court describes the dynamic between the two women?

Note 3. What is the purpose of making an employer vicariously liable for the kind of dynamic described here? What effect will a ruling like this one have in the workplace?

¹⁸ Editor’s note: “*res gestae*” means the things or circumstances relating to the case at hand.

Note 4. The principal case mentions a prior case, *International & G.N.R. Co. v. Henderson*, in which “a negro passenger, with the knowledge of the conductor, was vilified and made to dance for the amusement of the passengers by several drunken rowdies, who had entered the train.” The paragraphs below, excerpted from *International & G.N.R. Co.*, provide further details on the experience of Mr. Henderson, the African-American plaintiff targeted by drunken passengers.

International & G.N.R. Co. v. Henderson, Court of Civil Appeals of Texas (1904) (82 S.W. 1065)

[***] [A]ppellee was a passenger on one of appellant’s passenger trains from San Antonio to Austin, and further alleged: That during the time that said passenger train was on its way to Austin from San Antonio, and while plaintiff was on the train as a passenger, seated in the car set apart for the use of colored passengers (plaintiff being a colored man), the said car was invaded by several intoxicated or partially intoxicated white men, to plaintiff unknown, who made use of said car set apart for the use of colored passengers as a smoking car; said unknown white men were rude, boisterous, vulgar, and profane, cursing and swearing in the presence of plaintiff and several colored women, among whom was the wife of the plaintiff. The plaintiff remonstrated with the white men who had invaded the car set apart to the colored passengers, and was then abused, cursed, and vilified in the most vulgar and indecent language, and was marched through the train at the point of pistols held in the hands of the white men, and compelled to get off said train at the first station through which the plaintiff passed. That he caught the last car on the train after being compelled to get off, and once more seated himself as a passenger on the passenger train of defendant, but was again seen by the crowd of white men, as hereinbefore alleged, and was again cursed and vilified by said crowd of men, and compelled to march through the train at the point of pistols, and made to dance for the amusement of fellow passengers, searched, and again compelled to get off the train at the first station through which the passenger train passed; and then the plaintiff appealed to the conductor of said train for protection, informing the conductor that he was a passenger, and entitled to protection as a passenger. The conductor informed the plaintiff that he could do nothing for him, and for him (the plaintiff) to get on the blind baggage car. That he then again got upon the train, but the same crowd of white men compelled him, at the point of pistols, to again walk to and fro through the train, and when the train reached the station of Buda the plaintiff was compelled to get off and leave said train at the point of pistols and in fear of his life, and was not allowed by said crowd of white men to again get upon the train. That the plaintiff appealed to the conductor and the other trainmen in control of the train, but he was told that they could do nothing for him. That, after being compelled to get off the train at Buda, he walked to Austin, a distance of 12 miles, arriving next morning, as it was night when plaintiff was put off and required to leave the train at Buda. The petition alleges that the facts as stated were known to the conductor and the servants in charge of the train. And the petition concludes with the statement that he has been greatly damaged, in being placed in fear of his life and great bodily harm, and that he suffered great anguish in body and mind on account of the mistreatment as herein alleged, and sues for the sum of \$5,000. There is abundant evidence in the record sustaining these averments.

[***] The evidence in the record, and the case as made by the pleadings, is not one wholly of mental anguish, but it shows an unjustifiable assault made by drunken passengers upon the person of the appellee at a time and under circumstances when he should have been afforded protection by the conductor and the servants in charge of the train. They knew and were informed of the outrageous and

unjustifiable assault that was being committed, and there is no palliation or excuse for the conduct of the railway company in not resorting to some means to afford protection to the plaintiff from the premeditated, unjustifiable, and outrageous assault that was being committed upon him, the progress of which, as the evidence shows, continued for some time, within the knowledge of the conductor. On the points of law raised in the assignments noticed, the authorities in this state are clearly against the contention of the appellant. *Texas & Pacific Railway Co. v. Armstrong*, 93 Tex. 34; *Missouri Pacific Railway Co. v. Kaiser*, 82 Tex. 144; *M., K. & T. Ry. Co. v. Tarwater* (Tex.Civ.App.) 75 S.W. 937; *International & Great Northern Railroad Co. v. Anchondi* (Tex.Civ.App.) 68 S.W. 744.

The fifth assignment of error complains that the verdict of the jury is excessive, outrageous, and unconscionable, and that the court erred in overruling defendant's motion for new trial, because the damages awarded to the plaintiff are out of all proportion to the inconvenience and humiliation alleged to have been suffered by him. In view of the evidence in the record, it is unnecessary to discuss the question raised by this assignment. The plaintiff was clearly entitled to the amount recovered [\$1,000], if not more.

Note 5. Having read the account of Mr. Henderson's experience, consider how it compares with the experience of Mrs. Luther in the waiting room, recalling that both incidents were alleged to have resulted in emotional distress. What do you observe about how the court in *Gulf v. Luther* cites to this case, *International & G.N.R. Co. v. Henderson*? What does it suggest about a system built on stare decisis?

Professor Kim Lane Scheppele describes how a legal system ceases to feel legitimate when it discredits or misrepresents those whom it purports to represent and regulate: "Those whose stories are believed have the power to create fact; those whose stories are not believed live in a legally sanctioned 'reality' that does not match their perceptions. ...How are people to think about the law when their stories, the ones they have lived and believed, are rejected by courts, only to be replaced by other versions with different legal results? ...[T]here are few things more disempowering in law than having one's own self-believed story rejected, when rules of law (however fair in the abstract) are applied to facts that are not one's own, when legal judgments proceed from a description of one's own world that one does not recognize..." *Foreword: Telling Stories*, 87 Mich. L. Rev. 2073, 2079–80 (1989) What should courts do to guard against citation practices like those illustrated in the *Luther* and *Henderson* cases?

Check Your Understanding (1-10)

Question 1. Read the following dicta from *Gulf v. Luther* and select the answer that most accurately captures the meaning of the passage:

“While the rule, expressed in the court’s charge, that ‘railway companies are not insurers of the safety and comfort of their passengers, but are required to exercise that high degree of care that very cautious and prudent persons would have exercised under the same or similar circumstances, and a failure to do so is negligence,’ may not be strictly applicable to a case of this character, its being given in the charge [to the jury] could not have possibly prejudiced the defendant, since in a case like this the common carrier is absolutely liable for injuries unlawfully and wrongfully inflicted by his servant on a passenger.”

An interactive H5P element has been excluded from this version of the text. You can view it online here: <https://saidtorts2d.lawbooks.cali.org/?p=32#h5p-20>

Question 2. Which of the following is the least applicable normative justification for the doctrine of vicarious liability?

An interactive H5P element has been excluded from this version of the text. You can view it online here: <https://saidtorts2d.lawbooks.cali.org/?p=32#h5p-21>

Ruiz v. Bertolotti, Supreme Court, Nassau County (1962) (NY 37 Misc.2d 1067)

On this motion to dismiss the complaint for legal insufficiency pursuant to Rule 106 subdivision 4, Rules of Civil Practice, much of defendant’s argument is directed to the plausibility of the plaintiffs’ story, and whether the acts complained of ever occurred since the complaint is based only upon information and belief. We are not now, however, concerned with the question of proof since on a motion of this type the allegations must be deemed true.

In sum the complaint states that the plaintiffs, who are Puerto Ricans, contracted to purchase a house in a residential section of Massapequa from one Farber, a builder; that the defendant learned of this and he, acting in concert with others, personally called on Farber and expressed anger at ‘colored persons’ moving into the neighborhood, and threatened bodily harm to him, to plaintiffs and to plaintiffs’ children, if the sale were consummated; that these threats were made with malice and for

the purpose of communication to plaintiffs, in order to frighten them into agreeing to rescind the contract of sale; that these threats were communicated to plaintiffs by Farber and that plaintiffs were put in fear of their personal safety and that of their children as a result of which they entered into an agreement rescinding the contract of sale. It is further alleged that, as a result of these threats, both plaintiffs suffered distress, humiliation and emotional shock and were rendered sick and nervous, and that in addition plaintiff Manuel Ruiz suffered pecuniary damage in that he had to search for another dwelling and absent himself from his business.

Much of the discussion in the moving brief, in the court's view, is beside the point. This does not purport to be an action under the new anti-discrimination laws, nor in defamation, nor for assault, so there is no point in showing its deficiencies in this regard. [***]

This is an action for a wilful and malicious tort, the very purpose of which was to so frighten and distress the plaintiffs that they would surrender their legal right to buy a house where they pleased. These were not mere idle words of disapproval but a specific threat of bodily harm. The ultimate purpose of keeping 'colored people' out of the neighborhood could not be accomplished unless the immediate objective of putting them in fear for their safety first succeeded.

In principle this case is not too different from *Halio v. Lurie*, 15 A.D.2d 62, 222 N.Y.S.2d 759, where a malicious, sarcastic letter, taunting the *1069 plaintiff with her unsuccessful efforts to marry the defendant was held to be actionable without a showing of special damage. *Battalla v. State*, 10 N.Y.2d 237, is analogous also. There the Court of Appeals overruled the long established rule of *Mitchell v. Rochester Ry. Co.*, 151 N.Y. 107, that there could be no recovery for negligently causing fright, distress and physical damage, unless there had been an impact and allowed a complaint to stand although no physical contact was involved.

Deliberate and malevolent conduct, albeit confined to words, is at least as serious a matter, requiring the protection of the law to even a greater degree. (*Scheman v. Schlein*, 35 Misc.2d 581.)

The fact that the threat was uttered to an intermediary for communication to plaintiffs does not, in any way, detract from its viciousness and illegality. An 'organizer' who goes into a barber shop and tells an employee to tell the employer to raise the price of haircuts or his shop will be dynamited, would get short shrift with the defense that he did not speak to the employer personally.

For these reasons I believe that defendant must come forward and stand on his position that the episode did not take place and not that he is not liable even if it did happen, which is his position on this motion.

Motion denied.

Note 1. The court attempts to sort the defendant's conduct into one of tort law's existing categories: "This does not purport to be an action under the new anti-discrimination laws, nor in defamation, nor for assault, so there is no point in showing its deficiencies in this regard." What do you make of this effort, and how does it square with the outcome in this case?

Note 2. Having now had a brief introduction to trespass, battery, and assault—three of the core intentional torts—what do you observe about the way they were applied in the cases you read, whom they served or disserved, and how they differed from negligence law?

Chapter 6. Intentional Torts vs Negligence (Socratic Script)

Questions and Areas of Focus for the Readings

- Can you articulate the significance of a “general verdict” and its effect here?
- What is the role of the jury and jury instructions, in this case?
- Why does it matter to distinguish between battery and negligence?
- What key facts in this case did the court focus on, to distinguish between the applicability of the two regimes (the regimes of battery and negligence, that is)?

Cobbs v. Grant, Supreme Court of California, en banc, (1972) (8 Cal.3d 229)

This medical malpractice case involves two issues: first, whether there was sufficient evidence of negligence in the performing of surgery to sustain a jury verdict for plaintiff; second, whether, under plaintiff’s alternative theory, the instructions to the jury adequately set forth the nature of a medical doctor’s duty to obtain the informed consent of a patient before undertaking treatment. We conclude there was insufficient evidence to support the jury’s verdict under the theory that defendant was negligent during the operation. Since there was a general verdict and we are unable to ascertain upon which of the two concepts the jury relied, we must reverse the judgment and remand for a new trial. To assist the trial court upon remand we analyze the doctor’s duty to obtain the patient’s informed consent and suggest principles for guidance in drafting new instructions on this question.

Plaintiff was admitted to the hospital in August 1964 for treatment of a duodenal ulcer. He was given a series of tests to ascertain the severity of his condition and, through administered medication to ease his discomfort, he continued to complain of lower abdominal pain and nausea. His family physician, Dr. Jerome Sands, concluding that surgery was indicated, discussed prospective surgery with plaintiff and advised him in general terms of the risks of undergoing a general anesthetic. Dr. Sands called in defendant, Dr. Dudley F. P. Grant, a surgeon, who after examining plaintiff, agreed with Dr. Sands that plaintiff had an intractable peptic duodenal ulcer and that surgery was indicated. Although Dr. Grant explained the nature of the operation to plaintiff, he did not discuss any of the inherent risks of the surgery.

***235** A two-hour operation was performed the next day, in the course of which the presence of a small ulcer was confirmed. Following the surgery the ulcer disappeared. Plaintiff’s recovery appeared to be uneventful, and he was permitted to go home eight days later. However, the day after he returned home, plaintiff began to experience intense pain in his abdomen. He immediately called Dr. Sands who advised him to return to the hospital. Two hours after his readmission plaintiff went into shock and emergency surgery was performed. It was discovered plaintiff was bleeding internally as a result of a severed artery at the hilum of his spleen. Because of the seriousness of the hemorrhaging and since the spleen of an adult may be removed without adverse effects, defendant decided to remove the spleen. Injuries to the spleen that compel a subsequent operation are a risk inherent in the type of surgery performed on plaintiff and occur in approximately 5 percent of such operations.

After removal of his spleen, plaintiff recuperated for two weeks in the hospital. A month after discharge he was readmitted because of sharp pains in his stomach. X-rays disclosed plaintiff was developing a gastric ulcer. The evolution of a new ulcer is another risk inherent in surgery performed to relieve a duodenal ulcer. Dr. Sands initially decided to attempt to treat this nascent gastric ulcer with antacids and a strict diet. However, some four months later plaintiff was again hospitalized when the gastric ulcer continued to deteriorate and he experienced severe pain. When plaintiff began to vomit blood the defendant and Dr. Sands concluded that a third operation was indicated: a gastrectomy with removal of 50 percent of plaintiff's stomach to reduce its acid-producing capacity. Some time after the surgery, plaintiff was discharged, but subsequently had to be hospitalized yet again when he began to bleed internally due to the premature absorption of a suture, another inherent risk of surgery. After plaintiff was hospitalized, the bleeding began to abate and a week later he was finally discharged.

Plaintiff brought this malpractice suit against his surgeon, Dr. Grant. The action was consolidated for trial with a similar action against the hospital. The jury returned a general verdict against the hospital in the amount of \$45,000. This judgment has been satisfied. The jury also returned a general verdict against defendant Grant in the amount of \$23,800. He appeals.

The jury could have found for plaintiff either by determining that defendant negligently performed the operation, or on the theory that defendant's failure to disclose the inherent risks of the initial surgery vitiated plaintiff's consent to operate. Defendant attacks both possible grounds of *236 the verdict. He contends, first, there was insufficient evidence to sustain a verdict of negligence, and, second, the court committed prejudicial error in its instruction to the jury on the issue of informed consent.

I

Defendant's attack on the sufficiency of the evidence relates to the state of the medical testimony. Three experts testified at the trial: defendant, Dr. Sands, and defendant's expert, Dr. Yates. No expert witness was produced by plaintiff. The three experts were consistent in the opinion that the decision to operate as well as the actual procedure evidenced due care. Thus defendant insists that if experts unanimously opine that the defendant exercised due care, the jury may not substitute its judgment and find negligence. [cc]

Plaintiff contends the jury could reach a conclusion contrary to that of the experts because the decision to operate on his duodenal ulcer comes under the recognized exception to the need for medical testimony: the facts present a medical question resolvable by common knowledge. [cc] Where a shoulder is injured in an appendectomy (*Ybarra v. Spangard* (1944) 25 Cal.2d 486), or a clamp is left in the abdomen (*Leonard v. Watsonville Community Hosp.* (1956) 47 Cal.2d 509), expert testimony is not required since the jury is capable of appreciating and evaluating the significance of such events. However, when a doctor relates the facts he has relied upon in support of his decision to operate, and where the facts are not commonly susceptible of comprehension by a lay juror, medical expert opinion is necessary to enable the trier of fact to determine if the circumstances indicated a need for surgery.

The record before us requires this case to be governed by the general rule. An X-ray examination of plaintiffs' stomach disclosed 'There is extreme irritability of the duodenal bulb within which on two films is a faint collection of barium (swallowed by plaintiff for the purposes of this test) consistent with a very tiny active duodenal ulcer.' Since it was a 'very tiny' ulcer, and since conversely, the ulcer was 'active' and had produced 'extreme irritability,' only an expert would be capable of understanding whether surgery was immediately necessary for plaintiff's wellbeing. Similarly *237 there was

uncontradicted testimony that although plaintiff had ceased to experience pain rhythmically, continuous pain indicated the ulcer was penetrating the wall of the duodenum. If all five layers of the duodenum are penetrated a patient can bleed profusely and emergency surgery is essential to save his life. Again only an expert can appreciate the significance of the constant pain and whether surgery was indicated therefor. Finally there was evidence plaintiff's stools were dark and tarry. While the lay mind is unable to draw any conclusion from such evidence, to a doctor this is additional confirmation of a penetrating ulcer. Under such circumstances the common knowledge exception to the need for expert medical testimony is not applicable.

A fortiori, plaintiff's theory of negligence in the performance of the surgery is not sustainable under the common knowledge exception when, under these circumstances, there is uncontradicted expert testimony the operation had been performed with due care. Even with the exercise of due care the spleen may be injured during operations similar to that performed on plaintiff approximately 5 percent of the time, due to the need to mechanically retract the spleen to obtain access to the site of the operation. 'The fact that a particular injury suffered by a patient as the result of an operation is something that rarely occurs does not in itself prove that the injury was probably caused by the negligence of those in charge of the operation.' [c]

In any event, plaintiff contends, defendant made statements from which the jury could conclude defendant had admitted negligence. Defendant is a medical expert; if he in fact made inculpatory declarations of negligence, such admissions could be deemed the expert testimony necessary to sustain the verdict. However, the evidence pointed out by plaintiff in support of this theory does not constitute an admission of negligence. Plaintiff first emphasized testimony by defendant that surgery is not necessary for most ulcers unless there are complications. Plaintiff argues that from such testimony, in light of plaintiff's medical history, the jury could conclude there was no indication of a need for surgery. This is merely a restatement of the common knowledge argument which we have rejected above. Defendant's statement that surgery is not usually warranted is not an admission of a negligent decision to operate when all the medical experts testified that in plaintiff's case surgery was indicated.

Plaintiff also urges that although defendant testified he visually inspected the spleen before suturing, the jury could infer from the subsequent hemorrhaging *238 that his inspection was not made with due care. The bleeding was attributable to a small tear at the hilum of the spleen. Defendant and his expert witnesses gave uncontradicted testimony that injuries not apparent during an operation may subsequently become manifest. In light of this testimony and the additional uncontradicted testimony that the surgery was performed with due care, it would have been improper speculation for the jury to infer the injury should have been apparent to a careful surgeon. [c]

Finally, plaintiff relies on his own testimony that defendant said to plaintiff, 'He (i.e., defendant) blamed himself for me being back in there (the hospital for a second time).' Defendant denied having made such a remark. However, even if the jury had chosen to believe plaintiff, defendant's statement signifies compassion, or at most, a feeling of remorse, for plaintiff's ordeal. Since a medical doctor is not an insurer of result, such an equivocal admission does not constitute a concession that he lacked or failed to use the reasonable degree of learning and skill ordinarily possessed by other members of the profession in good standing in the community, or that he failed to exercise due care. [cc]

We are convinced there is not substantial evidence to support a jury verdict on the issue of defendant's liability on the theory that he was negligent either when he decided to operate or in performing the

surgery. Under article VI, section 13, of the California Constitution, we must examine the record to determine if the giving of instructions on this issue may have prejudiced the jury and caused a miscarriage of justice. The test we apply is whether it is reasonably probable a result more favorable to the appealing party would have been reached in the absence of the error. [c] Inasmuch as there was a general verdict, we cannot know whether the jury found defendant liable on the theory his decision to undertake, or the performance of, the operation was negligent, or whether it found him liable under the alternative theory: failure to obtain plaintiff's informed consent for surgery. It is clear from the record that both concepts were vigorously presented to the jury. Since it is impossible to determine on which theory the jury verdict rested, we conclude it is reasonably probable there has been a miscarriage of justice. We therefore reverse the judgment.

*239 II

Since the question of informed consent is likely to arise on retrial, we address ourselves to that issue. (Code Civ.Proc., s 43.) In giving its instruction the trial court relied upon *Berkey v. Anderson* (1969) 1 Cal.App.3d 790, 803, a case in which it was held that if the defendant failed to make a sufficient disclosure of the risks inherent in the operation, he was guilty of a 'technical battery' [cc] While a battery instruction may have been warranted under the facts alleged in *Berkey*, in the case before us the instruction should have been framed in terms of negligence.

Where a doctor obtains consent of the patient to perform one type of treatment and subsequently performs a substantially different treatment for which consent was not obtained, there is a clear case of battery. (*Berkey v. Anderson* (1969) supra, 1 Cal.App.2d 790 (allegation of consent to permit doctor to perform a procedure no more complicated than the electromyograms plaintiff had previously undergone, when the actual procedure was a myelogram involving a spinal puncture); *Bang v. Charles T. Miller Hosp.* (1958) 251 Minn. 427 (plaintiff consented to a prostate resection when uninformed that this procedure involved tying off his sperm ducts); *Corn v. French* (1955) 71 Nev. 280 (patient consented to exploratory surgery; doctor performed a mastectomy); *Zoterell v. Repp* (1915) 187 Mich. 319 (consent given for a hernia operation during which doctor also removed both ovaries).

However, when an undisclosed potential complication results, the occurrence of which was not an integral part of the treatment procedure but merely a known risk, the courts are divided on the issue of whether this should be deemed to be a battery or negligence. (*Gray v. Grunnagle* (1966) 423 Pa. 144 (failure to warn a patient a spinal operation involved an inherent risk of permanent paralysis; battery); *Belcher v. Carter* (1967) 13 Ohio App.2d 113 (failure to warn of danger of radiation burns; battery); *Nolan v. Kechijian* (1949) 75 R.I. 165 (operation to strengthen ligaments of spleen when spleen was removed; trespass to the body and negligence); [c] *Mitchell v. Robinson* (Mo.1960) 334 S.W.2d 11 (vertebrae broken during insulin shock treatment; negligence).) California authorities have favored a negligence theory. *240 (*Carmichael v. Reitz* (1971) 17 Cal.App.3d 958 (pulmonary embolism caused by adverse reaction to drug; negligence); *Dunlap v. Marine* (1966) 242 Cal.App.2d 162 (cardiac arrest allegedly caused by administration of anesthetic; negligence); *Tangora v. Matanky* (1964) 231 Cal.App.2d 468 (anaphylactic shock as a result of intramuscular penicillin shot; negligence); *Salgo v. Leland Stanford, etc., Bd. of Trustees* (1957) 154 Cal.App.2d 560 (paralysis of lower extremities after aortographic examination; negligence).)

Dean Prosser surveyed the decisions in this area and concluded, 'The earliest cases treated this as a matter of vitiating the consent, so that there was liability for battery. Beginning with a decision in

Kansas in 1960 (*Natanson v. Kline* (1960) [c], 187 Kan. 186), it began to be recognized that this was really a matter of the standard of professional conduct . . . (T)he prevailing view now is that the action . . . is in reality one for negligence in failing to conform to the proper standard . . .’ [cc]

Although this is a close question, either prong of which is supportable by authority, the trend appears to be towards categorizing failure to obtain informed consent as negligence. That this result now appears with growing frequency is of more than academic interest; it reflects an appreciation of the several significant consequences of favoring negligence over a battery theory. As will be discussed *Infra*, most jurisdictions have permitted a doctor in an informed consent action to interpose a defense that the disclosure he omitted to make was not required within his medical community. However, expert opinion as to community standard is not required in a battery count, in which the patient must merely prove failure to give informed consent and a mere touching absent consent. Moreover a doctor could be held liable for punitive damages under a battery count, and if held liable for the intentional tort of battery he might not be covered by his malpractice insurance. (Comment, *Informed Consent in Medical Malpractice* (1967) 55 Cal.L.Rev. 1396.) Additionally, in some jurisdictions the patient has a longer statute of limitations if he sues in negligence.

We agree with the majority trend. The battery theory should be reserved for those circumstances when a doctor performs an operation to which the patient has not consented. When the patient gives permission to perform one type of treatment and the doctor performs another, the requisite element of deliberate intent to deviate from the consent given is present. However, when the patient consents to certain treatment and the doctor performs that treatment but an undisclosed inherent complication with a low probability occurs, no intentional deviation from the consent *241 given appears; rather, the doctor in obtaining consent may have failed to meet his due care duty to disclose pertinent information. In that situation the action should be pleaded in negligence.

The facts of this case constitute a classic illustration of an action that sounds in negligence. Defendant performed the identical operation to which plaintiff had consented. The spleen injury, development of the gastric ulcer, gastrectomy and internal bleeding as a result of the premature absorption of a suture, were all links in a chain of low probability events inherent in the initial operation.

III

Since this is an appropriate case for the application of a negligence theory, it remains for us to determine if the standard of care described in the jury instruction on this subject properly delineates defendant’s duty to inform plaintiff of the inherent risks of the surgery. In pertinent part, the court gave the following instruction: ‘A physician’s duty to disclose is not governed by the standard practice in the community; rather it is a duty imposed by law. A physician violates his duty to his patient and subjects himself to liability if he withholds any facts which are necessary to form the basis of an intelligent consent by the patient to the proposed treatment.’

Defendant raises two objections to the foregoing instruction. First, he points out that the majority of the California cases have measured the duty to disclose not in terms of an absolute, but as a duty to reveal such information as would be disclosed by a doctor in good standing within the medical community. [cc] One commentator has imperiously declared that ‘good medical practice is good law.’ (*Hagman, The Medical Patient’s Right to Know* (1970) 17 U.C.L.A. L.Rev. 758, 764.) Moreover, with one state and one federal exception every jurisdiction that has considered this question has adopted the community standard as the applicable test. [fn] Defendant’s second contention is that this near

unanimity reflects strong policy reasons for vesting in the medical community the unquestioned *242 discretion to determine if the withholding of information by a doctor from his patient is justified at the time the patient weighs the risks of the treatment against the risks of refusing treatment.

The thesis that medical doctors are invested with discretion to withhold information from their patients has been frequently ventilated in both legal and medical literature. (See, e.g., *Salgo v. Leland Stanford, etc., Bd. of Trustees* (1957) *supra*, 154 Cal.App.2d 560, 578; *Mitchell v. Robinson* (Mo.1960) *supra*, 334 S.W.2d 11 (even though patient was upset, agitated, depressed, crying, had marital problems and had been drinking, the court found that since no emergency existed and he was legally competent he should have been advised of the risks of shock therapy) [...] Despite what defendant characterizes as the prevailing rule, it has never been unequivocally adopted by an authoritative source. Therefore we probe anew into the rationale which purportedly justifies, in accordance with medical rather than legal standards, the withholding of information from a patient.

Preliminarily we employ several postulates. The first is that patients are generally persons unlearned in the medical sciences and therefore, except in rare cases, courts may safely assume the knowledge of patient and physician are not in parity. The second is that a person of adult years and in sound mind has the right, in the exercise of control over his own body, to determine whether or not to submit to lawful medical treatment. The third is that the patient's consent to treatment, to be effective, must be an informed consent. And the fourth is that the patient, being unlearned in medical sciences, has an abject dependence upon and trust in his physician for the information upon which he relies during the decisional process, thus raising an obligation in the physician that transcends arms-length transactions.

From the foregoing axiomatic ingredients emerges a necessity, and a resultant requirement, for divulgence by the physician to his patient of all information relevant to a meaningful decisional process. In many instances, to the physician, whose training and experience enable a self-satisfying evaluation, the particular treatment which should be undertaken may seem evident, but it is the prerogative of the patient, not the physician, to determine for himself the direction in which he believes his interests lie. *243 To enable the patient to chart his course knowledgeably, reasonable familiarity with the therapeutic alternatives and their hazards becomes essential.

Therefore, we hold, as an integral part of the physician's overall obligation to the patient there is a duty of reasonable disclosure of the available choices with respect to proposed therapy and of the dangers inherently and potentially involved in each.

A concomitant issue is the yardstick to be applied in determining reasonableness of disclosure. This defendant and the majority of courts have related the duty to the custom of physicians practicing in the community. [cc] The majority rule is needlessly overbroad. Even if there can be said to be a medical community standard as to the disclosure requirement for any prescribed treatment, it appears so nebulous that doctors become, in effect, vested with virtual absolute discretion. (See Note, *Physicians and Surgeons* (1962) 75 Harv.L.Rev. 1445; *Waltz and Scheuneman, Informed Consent to Therapy* (1970) 64 Nw.U.L.Rev. 628.) The court in *Canterbury v. Spence*, *supra*, 464 F.2d 772, 784, bluntly observed: 'Nor can we ignore the fact that to bind the disclosure obligation to medical usage is to arrogate the decision on revelation to the physician alone. Respect for the patient's right of self-determination on particular therapy demands a standard set by law for physicians rather than one which physicians may or may not impose upon themselves.' Unlimited discretion in the physician is

irreconcilable with the basic right of the patient to make the ultimate informed decision regarding the course of treatment to which he knowledgeably consents to be subjected.

A medical doctor, being the expert, appreciates the risks inherent in the procedure he is prescribing, the risks of a decision not to undergo the treatment, and the probability of a successful outcome of the treatment. But once this information has been disclosed, that aspect of the doctor's expert function has been performed. The weighing of these risks against the individual subjective fears and hopes of the patient is not an expert skill. Such evaluation and decision is a nonmedical judgment reserved to the patient alone. A patient should be denied the opportunity to weigh the risks only where it is evident he cannot evaluate the data, as for example, where there is an emergency or the patient is a child or incompetent. For this reason the law provides that in an emergency consent is implied *244 [cc] and if the patient is a minor or incompetent, the authority to consent is transferred to the patient's legal guardian or closest available relative [cc]. In all cases other than the foregoing, the decision whether or not to undertake treatment is vested in the party most directly affected: the patient.

The scope of the disclosure required of physicians defies simple definition. Some courts have spoken of 'full disclosure' [cc] and others refer to "full and complete" disclosure [cc] but such facile expressions obscure common practicalities. Two qualifications to a requirement of 'full disclosure' need little explication. First, the patient's interest in information does not extend to a lengthy polysyllabic discourse on all possible complications. A mini-course in medical science is not required; the patient is concerned with the risk of death or bodily harm, and problems of recuperation. Second, there is no physician's duty to discuss the relatively minor risks inherent in common procedures, when it is common knowledge that such risks inherent in the procedure are of very low incidence.[fn] For example, the risks inherent in the simple process of taking a common blood sample are said to include hematoma, dermatitis, cellulitis, abscess, osteomyelitis, septicemia, endocarditis, thrombophlebitis, pulmonary embolism and death, to mention a few. (Harrison, *Principles of Internal Medicine* (5th ed. 1966) pp. 726, 1492, 1510-1514.) One commentator states that California law does not require that the "patient be told too much." (Hagman, *The Medical Patient's Right to Know*, *supra*, 17 U.C.L.A. L.Rev. 758, 766.)[/footnote] When there is a common procedure a doctor must, of course, make such inquiries as are required to determine if for the particular patient the treatment under consideration is contraindicated—for example, to determine if the patient has had adverse reactions to antibiotics; but no warning beyond such inquiries is required as to the remote possibility of death or serious bodily harm.

However, when there is a more complicated procedure, as the surgery in the case before us, the jury should be instructed that when a given procedure inherently involves a known risk of death or serious bodily harm, a medical doctor has a duty to disclose to his patient the potential of death or serious harm, and to explain in lay terms the complications that might possibly occur. Beyond the foregoing minimal disclosure, a doctor must also reveal to his patient such additional information as *245 a skilled practitioner of good standing would provide under similar circumstances.

In sum, the patient's right of self-decision is the measure of the physician's duty to reveal. That right can be effectively exercised only if the patient possesses adequate information to enable an intelligent choice. The scope of the physician's communications to the patient, then, must be measured by the patient's need, and that need is whatever information is material to the decision. Thus the test for determining whether a potential peril must be divulged is its materiality to the patient's decision. (*Canterbury v. Spence*, *supra*, 464 F.2d 772, 786.)

We point out, for guidance on retrial, an additional problem which suggests itself. There must be a causal relationship between the physician's failure to inform and the injury to the plaintiff. Such causal connection arises only if it is established that had revelation been made consent to treatment would not have been given. Here the record discloses no testimony that had plaintiff been informed of the risks of surgery he would not have consented to the operation. [cc]

The patient-plaintiff may testify on this subject but the issue extends beyond his credibility. Since at the time of trial the uncommunicated hazard has materialized, it would be surprising if the patient-plaintiff did not claim that had he been informed of the dangers he would have declined treatment. Subjectively he may believe so, with the 20/20 vision of hindsight, but we doubt that justice will be served by placing the physician in jeopardy of the patient's bitterness and disillusionment. Thus an objective test is preferable: i.e., what would a prudent person in the patient's position have decided if adequately informed of all significant perils. (*Canterbury v. Spence*, supra, 464 F.2d 772, 787.)

The burden of going forward with evidence of nondisclosure rests on the plaintiff. Once such evidence has been produced, then the burden of going forward with evidence pertaining to justification for failure to disclose shifts to the physician.

Whenever appropriate, the court should instruct the jury on the defenses available to a doctor who has failed to make the disclosure required by law. Thus, a medical doctor need not make disclosure of risks when the patient requests that he not be so informed. (See discussion of waiver: Hagman, *The Medical Patient's Right to Know*, supra, 17 U.C.L.A. L.Rev. 758, 785.) Such a disclosure need not be made if the procedure is simple and the danger remote and commonly appreciated to be remote. *246 A disclosure need not be made beyond that required within the medical community when a doctor can prove by a preponderance of the evidence he relied upon facts which would demonstrate to a reasonable man the disclosure would have so seriously upset the patient that the patient would not have been able to dispassionately weigh the risks of refusing to undergo the recommended treatment. (E.g., see discussion of informing the dying patient: Hagman, *The Medical Patient's Right to Know*, supra, 17 U.C.L.A. L.Rev. 758, 778.) Any defense, of course, must be consistent with what has been termed the 'fiducial qualities' of the physician-patient relationship. [c]

The judgment is reversed.

Note 1. From the plaintiff or patient's perspective, why does it matter to distinguish negligence from battery?

Note 2. From the defendant or physician's perspective, why does the distinction matter?

Note 3. Why does the court state a preference for the objective test for the patient in informed consent?

Expand On Your Understanding – Socratic Script: Cobbs v. Grant

Question 1. What were the legal issues in this case?

An interactive H5P element has been excluded from this version of the text. You can view it online here: <https://saidtorts2d.lawbooks.cali.org/?p=34#h5p-22>

Question 2. What was the holding in this case? Why could the verdict below not stand?

An interactive H5P element has been excluded from this version of the text. You can view it online here: <https://saidtorts2d.lawbooks.cali.org/?p=34#h5p-23>

Question 3. What is the dispute concerning expert testimony in the case, and how does the court justify its decision in that regard?

An interactive H5P element has been excluded from this version of the text. You can view it online here: <https://saidtorts2d.lawbooks.cali.org/?p=34#h5p-24>

Question 4. The court states that on retrial, below, the court would ordinarily need to determine whether to instruct the jury to consider informed consent in terms of *negligence* or *battery*. Which does it tell the court to apply, and what reasoning does it provide?

An interactive H5P element has been excluded from this version of the text. You can view it online here: <https://saidtorts2d.lawbooks.cali.org/?p=34#h5p-25>

Question 5. What are some real-world consequences that may flow from categorizing a claim as battery vs. negligence? What's the rationale underpinning the distinction?

An interactive H5P element has been excluded from this version of the text. You can view it online here: <https://saidtorts2d.lawbooks.cali.org/?p=34#h5p-26>

Check Your Understanding (1-11)

Question 1. Which of the following are instances in which the *Cobbs* ruling indicates that the patient need not be informed:

- i. When the patient requests that they not be informed
- ii. When the procedure is simple and the danger remote and commonly understood to be remote
- iii. When the patient's low risk is outweighed by the doctor's high risk of a costly but trivial malpractice claim
- iv. When the disclosure might so seriously upset the patient that they would not be able to weigh the risks of refusing treatment
- v. When the disclosure might cause the patient to seek alternative treatment or another surgeon

An interactive H5P element has been excluded from this version of the text. You can view it online here: <https://saidtorts2d.lawbooks.cali.org/?p=34#h5p-27>

Reflect On Your Understanding – Essay on the Implications of Tort Law's Impact (Recommended maximum word count 300 words)

Several of the cases we have read so far have involved elements of race, gender, class, ability and socioeconomic power. We have also discussed tort law's normative purposes (fairness, efficiency, compensation, deterrence, and social justice). Identify one example from a case in this module that shows courts failing to live up to one of these purposes. In your example, you might choose to discuss whether you see the court prioritizing one of tort law's purposes over another. If so, does the court justify that prioritization? Generally, what are you observing about how the law works, or fails to work? There is no "right" answer here; this essay question is simply intended to invite you to reflect on your readings and engage with the deeper ideas of the course.

MODULE 2. INTENTIONAL TORTS

In Module 1, you learned the differences between **negligence** (which governs the risk of injury and requires that people use ordinary (or reasonable) care in their conduct); **strict liability** (which imposes liability without fault or intent); and **the intentional torts** (which are organized around some level of intent to act in a way that causes harm). This last domain is our focus in Module 2, as we explore how tort law regulates conduct that reflects the **intention to invade the legally protected interests of another**, whether those interests are in the person's **body, mind, property, possessions, privacy or reputation**.

The intentional torts are, in some respects, an artificial grouping of torts characterized by what they lack: a purely accidental character. Even activities that cause policymakers to apply strict liability can rise to the level of intentional torts if in their conduct the parties cease to seem merely careless, or even reckless, and instead seem aware that their actions will invade legally protected interests. Despite the contemporary treatment of the many intentional torts under one umbrella, in fact the category is an invented one and these torts differ quite a bit from each other. The intent standard is not consistent across all of the intentional torts. For example, for one tort it drops down to recklessness (intentional infliction of emotional distress) and for another tort it rises to specific intent (false imprisonment). The proof requirements also differ: battery and trespass require no proof of harm for liability to arise (but without proof of harm, damages are likely to be only nominal). Yet false imprisonment requires confinement along with *awareness* of false imprisonment and intentional infliction of emotional distress requires not just distress but *severe* distress.

That the intentional torts continue to be grouped and taught together may owe something to their early English predecessors. In the early tort law (roughly from the 13th through 18th centuries), a system developed that required that legal actions be pled in specific ways using particular forms and “writs.” Failure to comply with strict pleading requirements or use of the wrong form resulted in dismissal of the case with prejudice and many actions were thus decided on formal rather than substantive grounds. The system worked well for plaintiffs who complied with pleading requirements, however; if they could correctly plead all the necessary elements, they were likely to win. The English writ system laid the foundation for our current intentional torts, most of which are characterized by a “rule-like” aspect. The intentional torts’ elements are often more easily pled and proven than the elements of negligence.

Over time, the writ system sorted wrongful actions into two kinds. The first were known as actions in “trespass” and they typically required that the plaintiff prove the defendant used **force** to cause a **direct invasion** of some protected interest. The second, which came only later, were actions known as “trespass on the case” and these permitted recovery more broadly, including for harm **not caused by force and harms caused indirectly**. Trespass on the case grew into a body of law that eventually provided the basis for American negligence law, which reflects that injured plaintiffs may be able to recover even when a defendant did not act with a particular intent or force and was merely negligent, and even when the defendant’s conduct was indirect or attenuated in some way. The contemporary intentional torts system likewise reflects the earlier trespass actions and shares characteristics of the writ system, such as distinct and rigid pleading requirements, a narrow scope of applicability and high likelihood of success for plaintiffs who can successfully plead the requisite elements. These “rule-like”

aspects are characteristic of the writ system and an important difference from negligence which is governed not by a rule but a standard—reasonableness.

Rules versus Standards

In the legal understanding “rules” tend to be characterized in the following way: they are clear, easier (and thus cheaper) to apply, generalized, rigid, inflexible (and perhaps sometimes unfair as a result). “Standards” tend to be characterized thus: they are less clear or even indeterminate; they are harder (and usually more expensive) to apply partly because they are capable of flexibility; they can be tailored to the facts at hand (but this also means they *must* be tailored to the facts at hand). A rule is conceptually something that can be applied without recourse to a body of norms or additional evidence (such as no smoking allowed). A standard is something that may require contextual information or extrinsic evidence (such as smoke only when other customers are reasonably far away). Philosophers and debaters among you will immediately spot that in fact rules are much more complicated than that; there are open-textured rules or rules with complicated terms and standards in some instances develop predictable patterns that make them easier to apply than it might seem. However, it’s a helpful distinction to employ especially when you shift gears from intentional torts to Negligence in later Modules.

Check Your Understanding (2-1)

Question 1. The United States Constitution, Art. II, Section 1 sets forth the eligibility requirements for serving as President of the United States: No Person except a natural born Citizen, or a Citizen of the United States, at the time of the Adoption of this Constitution, shall be eligible to the Office of President; neither shall any person be eligible to that Office who shall not have attained to the Age of thirty five Years, and been fourteen Years a Resident within the United States.

True or False: The mandate that the President of the United States must be at least 35 is a rule, not a standard.

An interactive H5P element has been excluded from this version of the text. You can view it online here: <https://saidtorts2d.lawbooks.cali.org/?p=36#h5p-28>

Learning to navigate the common law system requires that you develop skills of reading accurately, synthesizing case law and predicting outcomes and changes, to some extent. That’s one significant reason why history matters. Understanding a bit about the history of tort law’s origins, for instance, helps you understand why the intentional torts are narrowly construed and informs your educated

guesses about what a court is likely to do in a case of first impression. This historical context also helps explain why the intentional torts were eventually deemed insufficient to protect the range of interests considered vital and necessary to protect. The intentional torts were originally a narrowly defined set of torts meant to protect bodily autonomy. Assault, even though it captures non-physical harm, does so only because it was conceived of as a means of protecting the body and the mental state that arises when anticipating bodily harm. The tort of false imprisonment protects the freedom of movement, but though this is conceptual, it too orients the protection in the body. The tort of defamation protects the interest in maintaining one's reputation but this requires external manifestations in the form of communications to others that are provably harmful in some way. The big gap in coverage concerned suffering emotionally or psychologically in the absence of physical harm. When tortious conduct of any kind causes physical harm, a plaintiff may also recover for their emotional or psychological distress, which is considered "parasitic" of—or derived from—the physical harm. But what about the cases in which bad behavior results in emotional distress alone?

In *Wilkinson v. Downton*, 2 Queen's Bench Division 57 (1897), a court in England held that a woman could recover when she suffered shock after being the victim of a prank:

In this case the defendant, in the execution of what he seems to have regarded as a practical joke, represented to the plaintiff that he was charged by her husband with a message to her to the effect that her husband was smashed up in an accident, and was lying at The Elms at Leytonstone with both legs broken, and that she was to go at once in a cab with two pillows to fetch him home. All this was false. The effect of the statement on the plaintiff was a violent shock to her nervous system, producing vomiting and other more serious and permanent physical consequences at one time threatening her reason, and entailing weeks of suffering and incapacity to her as well as expense to her husband for medical attendance. These consequences were not in any way the result of previous ill-health or weakness of constitution; nor was there any evidence of predisposition to nervous shock or any other idiosyncrasy. [***] The defendant has, as I assume for the moment, wilfully done an act calculated to cause physical harm to the plaintiff — that is to say, to infringe her legal right to personal safety, and has in fact thereby caused physical harm to her. That proposition without more appears to me to state a good cause of action, there being no justification alleged for the act.

The judge declined to find fraud and distinguished prior cases that had withheld damages for emotional distress produced in connection with slander. Here, he found there was sufficient intent to cause some form of impact on the plaintiff and that should be enough, even though "no malicious purpose to cause the harm which was caused nor any motive of spite is imputed to the defendant." The court's recognition of what would be called "intentional infliction of mental shock" laid the groundwork for American courts to begin to consider and eventually adopt the tort of intentional infliction of emotional distress. However, that such an action was now viewed as *possible* did not mean that it was soon or routinely used. The Restatement (Second) of Torts § 46 was only amended in 1947 to reflect the possibility of recovery under IIED and California, a progressive jurisdiction with respect to torts, adopted it only in 1952. In the 1960s, some states began recognizing the tort as a standalone cause of action; others came later, such as Florida, which did not recognize the tort until 1985.

Many courts continue to cite to the Restatement's formulation of the tort in language that may be more evocative than helpful: "Liability has been found only where the conduct has been so outrageous in character, and so extreme in degree, as to go beyond all possible bounds of decency, and to be regarded as atrocious, and utterly intolerable in a civilized community. Generally, the case is one in which the recitation of the facts to an average member of the community would arouse his resentment against the actor, and lead him to exclaim, 'Outrageous!'" Restatement (Second) of Torts § 46 cmt. d (1965)

Whatever the similarities and differences in the technical aspects of the various intentional torts, their core conceptual difference remains that intent, rather than fault or policy, is present in a way that the law deems important. An oft-quoted line from the jurist Oliver Wendell Holmes suggests an intuition about why we divide these regimes in this way: "Even a dog knows the difference between being stumbled over and being kicked." Oliver Wendell Holmes, *The Common Law*, Mark DeWolfe Howe, ed. (Little Brown, 1963), p. 3. Something attaches to the knowledge that a harmful action was purely accidental in character; even if negligence or another claim is available against the actor, the moral judgment—and possibly legal implications—will weigh less heavily on the actor. If a person intentionally acts in such a way that another suffers harm, the pleading and proof standards will generally be easier for a plaintiff to meet and the defendant will be unable to assert the powerful defense of comparative negligence against the plaintiff. These differences reflect the system's recognition that the scale tips slightly towards the victim right from the start. The starting premise is that intent matters. The question will be how to define it. In many respects, defining intent is the most challenging aspect of the intentional torts whose rule-like qualities often otherwise make them more straightforward to learn than negligence law will prove to be.

Chapter 7. Intent

The intent level needed to satisfy most of the intentional tort action is an intent to act followed by the action itself. If an action is produced involuntarily (through a seizure, while sleeping or drugged against one's will, for instance), the actor lacks the requisite intent. If an actor throws a ball at someone, hoping they will catch it, the intent to throw is the focus of the inquiry. Some courts have called this “**purpose intent.**” If the throw causes bruising when the ball accidentally hits the receiver's face, it does not defeat the thrower's intent even if the harm was unintended. Tort law calls the intent to cause the harm that happened (here, the facial bruising), “**specific intent.**” Specific intent is not required for most of the intentional torts and it is an error of law to confuse the standards; specific intent is *higher than necessary* for most intentional torts. (The exception is false imprisonment which requires proof of the specific intent to confine the plaintiff.)

Restatement (Third) of Torts: Liability for Physical and Emotional Harm

§ 1. Intent: **A person acts with the intent to produce a consequence if:**

- (a) the person acts **with the purpose** of producing that consequence; or
- (b) the person acts **knowing** that the consequence is **substantially certain** to result.

Villa v. Derouen Court of Appeal of Louisiana, Third Circuit (1993) (614 So.2d 714)

This is an appeal by Eusebio Villa, plaintiff and appellant herein, from a jury verdict in favor of Michael Derouen, Villa's co-employee, and Louisiana Farm Bureau Mutual Insurance Company, Derouen's homeowner insurer, defendants and appellees herein. This case involves facts wherein an intentional act, by Derouen, i.e., the act of pointing a welding cutting torch in Villa's direction and intentionally releasing oxygen or acetylene gas caused unintentional harm to Villa, i.e., second degree burns to Villa's groin area.

After trial, the jury found that the defendant, Derouen, did not commit an intentional tort against Villa and, therefore, was not liable for Villa's injuries. This finding of the jury foreclosed Villa from recovery in this action insofar as Villa is limited to worker's compensation unless it was found that Derouen committed an intentional tort which caused Villa's injuries.

Villa appeals contending that the jury erred in its finding that Derouen did not commit an intentional tort against Villa. We agree with Villa's contentions and find that the jury clearly erred in finding that Derouen's intentional act of spraying his welding torch in Villa's direction did not constitute an intentional tort, specifically, a battery against Villa. As such, we reverse the judgment of the trial court and award damages accordingly.

This claim for damages arises out of an accident which occurred at M.A. Patout & Sons, Iberia Parish, Louisiana, on May 7, 1986. The evidence is undisputed that Eusebio Villa sustained burns to his crotch

area and that these burns were caused by the actions of his co-employee, Michael Derouen. At the time of the accident, Villa was welding with a welding torch or welding whip. Derouen was standing to his left, using a cutting torch. Intending only horseplay, although one-sided, Derouen turned toward Villa and discharged his torch. Under cross-examination, Derouen responded affirmatively when asked if he placed the torch between Villa's legs and also responded affirmatively when asked if he intended to spray Villa between the legs with oxygen when he placed the torch between Villa's legs.

On direct examination, in response to questioning by his own attorney, Derouen qualified his previous answers, as follows:

"Mr. Lambert: ... you did not have it in close proximity to his crotch?

Mr. Derouen: No.

Mr. Lambert: In fact, you did not even have it inside his body?

Mr. Derouen: No.

.....

Mr. Lambert: When you squirted that, did you intend that that air actually cause him any pain, even minor pain?

Mr. Derouen: No.

Mr. Lambert: Did you intend that he even feel anything from the little bit of air?

Mr. Derouen: No.

Mr. Lambert: Why did you do it? What was your intention of doing that?

Mr. Derouen: To get his attention."

Troy Mitchell, a co-employee, testified that a few minutes before the accident, he saw Derouen take his torch and blow pressurized oxygen behind Villa's neck into Villa's lowered face shield while Villa was welding. Mitchell testified that he told Derouen not to do that because it could ignite. Mitchell additionally testified that he thought Villa had also told Derouen to stop fooling around. Only a few minutes later, the accident which resulted in Villa's burns occurred. Mitchell did not witness the accident because his welding hood was down at the time.

Marty Frederick, a co-employee of Villa's, and Lambert Buteau, their supervisor, both testified that although they did not witness the incident, and could not remember Derouen's exact words after the incident, *716 both understood that Derouen, in relating what had happened, was playing around with the cutting torch and "goosing" or trying to scare Villa at the time of the accident.

Derouen testified that he sprayed pressurized oxygen near plaintiff's face prior to the accident. Villa testified that he felt the oxygen that Derouen blew on his face or head, heard Troy Mitchell telling Derouen to stop because Villa could be hurt, and made a remark himself to Derouen about it. Villa testified that, a few minutes later as he was welding with his face covered by his welding hood, he felt something blowing between his legs. He held still for a second, so as to not interrupt his welding, until he felt the pain in his groin area. He stated that, "I just grabbed with both of my hands. When I grabbed, it was a torch." He continued by stating, "I grabbed in my private area where I feel the fire, and right there was the torch. I pushed it like that. It was Michael Derouen with the torch in his hand."¹⁹

¹⁹ Mr. Villa is a Puerto Rican native who came to the United States for the first time in 1973 and has a strong Spanish accent.

The fact that Villa reached down to his groin at the time of the injury, and either grabbed the torch or pushed it away, was undisputed at trial. It was also undisputed that, at the time of the accident, Villa was crouched welding with his welding hood down. The evidence revealed that while he was welding, due to the noise caused by the welding, Villa would not have heard Derouen's torch aimed in his direction.

If an employee is injured as a result of an intentional act by a co-employee, LSA-R.S. 23:1032(B) allows him to pursue a tort remedy against that co-employee. In *Bazley v. Tortorich*, 397 So.2d 475 (La.1981), the Louisiana Supreme Court determined that "an intentional tort", for the purpose of allowing an employee to go beyond the exclusive remedy of worker's compensation, meant "the same as 'intentional tort' in reference to civil liability."

A civil battery has been defined by the Louisiana Supreme Court in *Caudle v. Betts*, 512 So.2d 389, 391 (La.1987) as, "[a] harmful or offensive contact with a person, resulting from an act intended to cause the plaintiff to suffer such a contact..." (Citations omitted.) The Louisiana Supreme Court in *Caudle*, supra, at page 391, continued by stating: "The intention need not be malicious nor need it be an intention to inflict actual damage. It is sufficient if the actor intends to inflict either a harmful or offensive contact without the other's consent. (Citations omitted.) ...

"The element of personal indignity involved always has been given considerable weight. Consequently, the defendant is liable not only for contacts that do actual physical harm, but also for those relatively trivial ones which are merely offensive and insulting. (Citations omitted.)

The intent with which tort liability is concerned is not necessarily a hostile intent, or a desire to do any harm. Restatement (Second) of Torts, American Law Institute § 13 (comment e) (1965). Rather it is an intent to bring about a result which will invade the interests of another in a way that the law forbids. The defendant may be liable although intending nothing more than a good-natured practical joke, or honestly believing that the act would not injure the plaintiff, or even though seeking the plaintiff's own good." (Citations omitted.)

Pursuant to this jurisprudence, we must determine whether Derouen committed a battery against Villa. Did Villa suffer an offensive contact which resulted from an act by Derouen which was intended to cause that offensive contact? Or as stated by *Bazley*, supra, at page 481, did Derouen entertain "a desire to bring about the consequences that followed", or did Derouen believe "that the result was substantially *717 certain to follow", thereby characterizing his act of spraying Villa as intentional?

There is a distinction between an intentional act which causes an intentional injury and an intentional act which causes an unintentional injury. To constitute a battery, Derouen need only intend that the oxygen he sprayed toward the plaintiff come into contact with Villa, or have the knowledge that this contact was substantially certain to occur.

The physical results or consequences which must be desired or known to a substantial certainty in order to rise to the level of an intentional tort, refer to the requirements of the particular intentional tort alleged. In this case, wherein Villa has alleged a battery, the harmful or *offensive contact* and not the resulting injury is the physical result which must be intended.

The record reveals that, although correctly instructed by the trial court, the jury appears to have been confused on this issue and, as such, manifestly erred, as a matter of law, in their verdict. The court instructed the jury as follows, as to the definition of the intentional tort of battery:

“In order for Eusebio Villa to recover from anyone in this case, he must first prove, by a preponderance of the evidence, that he was injured as a result of an intentional act. The meaning of intent in this context is that defendant either desired to bring about the physical results of his act, or believed that they were substantially certain to follow from what he did.

Eusebio Villa has alleged that Michael Derouen committed a battery upon him. A harmful or offensive contact with a person resulting from an act intending to cause the plaintiff to suffer such a contact is a battery. A battery in Louisiana law is an intentional act or tort.

The intention to commit the battery need not be malicious nor need it be an intention to inflict actual damage. The fact that it was done as a practical joke and did not intend to inflict actual damage does not render the actor immune. It is sufficient if the actor intends to inflict either a harmful or offensive contact without the other’s consent. It is an intent to bring about a result which will invade the interests of another in a way that the law forbids.”

Although this definition was technically correct, several defense counsels, both in opening and closing statements, told the jury that, in order for them to find Derouen liable, they must find that Derouen intended to hurt Villa and/or intended to burn Villa. Additionally, the jury was misled by statements that their verdict in favor of Villa would make Derouen a criminal insofar as a battery was a crime.

The jury voiced its confusion by sending a question to the judge asking him what the difference was between “an intentional tort and intentional (on purpose).” After the judge again instructed the jury with the charge set forth above, the jury sent out the query below [“Does the law in simple words means [sic] the intent to perform the act was meant but, not the harm resulting?”] to which the trial judge answered, as written [“The only response I can make is to reread the charge.”]: *718

② Does
The law in simple
words means - the
intent to perform the
act was meant but,
not the harm resulting?
The only response I can make is to reread the charge
Judge's answer

Clearly the jury was confused as to whether they were to determine Derouen's intent to perform the act or his intent to cause the resulting injuries. No clarifying instruction was given to the jury on this point of law. Had they understood the law, a reasonable juror could not have found that Derouen did not intend the act of directing compressed oxygen in the direction of Villa's groin.

This distinction between an intentional act or unintentional act was recently highlighted in *Lyons v. Airdyne Lafayette, Inc.*, 563 So.2d 260 (La.1990). In *Lyons*, an employee sued a co-employee alleging injuries as a result of the co-employee shooting a stream of compressed air at the plaintiff. The trial court granted summary judgment which was affirmed by this court. The Louisiana Supreme Court granted a writ of certiorari, and reversed the grant of summary judgment in favor of the defendant, stating as follows:

“There is a genuine issue of material fact whether plaintiff's co-employee intentionally shot the stream of compressed air at plaintiff and injured him or whether the co-employee accidentally released the stream while repairing the compressor.” *Id.* at page 260.

Conversely, in the case at bar, there is no question as to whether or not Derouen intentionally shot the stream of compressed air at Villa.

This is not a case of an accidental release of pressurized oxygen or gas in Villa's direction. Derouen testified that he did not intend, even the air he was pointing in Villa's direction, to come into contact with Villa. It was unreasonable for the jury to accept that Derouen blew his torch at Villa, while Villa was welding and surrounded by the accompanying noise, in order to get Villa's attention, but did not intend for Villa to *feel* the air directed at him.

In this case, Derouen intended to release the pressurized oxygen in Villa's direction, at a minimum, to get Villa's attention. Due to the noise, he would not have been able to get Villa's attention unless Villa felt the air.

The facts are undisputed that Derouen aimed his welding torch and sprayed the pressurized oxygen or gas, which ignited, at Villa's groin or at the ground between Villa's legs. It is also undisputed that Villa was injured by the contact with the “flash” of Derouen's welding torch.

***719** We find that the jury clearly erred in finding that a battery, i.e., an unconsented to offensive contact, had not occurred. The act or battery which Derouen intended was that of blasting pressurized oxygen or gas between Villa's legs, into his groin area. Derouen testified that he merely wanted to get Villa's attention. Due to the undisputed evidence that Villa was welding at the time of the injury, which welding was by its nature, accompanied by the noise of the welding, the defendant would not have approached Villa, expecting or intending him to “hear” the blast of air and thus, get his attention, without also expecting or intending Villa to “feel” the blast of pressurized oxygen and thus, get his attention.

Under the undisputed facts presented to the jury, we find that a reasonable juror could not have found that Derouen did not either intend for the air from his cutting torch to come into contact with Villa's groin or, alternatively, we find that a reasonable juror could not have found that Derouen, in pointing his torch at Villa and releasing pressurized oxygen in the area of Villa's groin, was not aware or substantially certain that the oxygen would come into contact with Villa's groin area.

Villa sustained second degree burns to his penis, scrotum, and both thighs. He was first seen by Dr. James Falterman, Sr. on May 8, 1986, who hospitalized him from May 8, 1986, through May 16, 1986. Dr. Falterman testified that Villa was reasonably comfortable, with pain medication and treatment, within three (3) to four (4) days and, at a maximum, within one (1) week after the accident. Villa's physical wounds healed completely, with some depigmentation, but no functional disability. He was discharged from treatment of his burns as of June 20, 1986.

Villa complained of being nervous and depressed on May 15, of 1986, and requested to see a psychiatrist. Villa was referred by Dr. Falterman to Dr. Warren Lowe, a clinical psychologist, who first saw Villa on June 9, 1986. Dr. Lowe diagnosed Villa as suffering from atypical anxiety disorder with depressive features together with some symptoms of post-traumatic stress disorder. At the time of trial, Dr. Lowe felt that Villa was getting better and was capable of entering a rehabilitation program.

[Editor's note: The court ordered Derouen and his homeowner's insurance company to pay \$174,307.00. Module 6, on damages, revisits this case.]

The jury's verdict finding that Michael Derouen did not commit an intentional tort is hereby reversed.

Note 1. Derouen testified that he did not intend for the air to make contact with Villa. How did the court dispose of that assertion? What did it say about the jury's verdict with respect to this point? Which standard of intent does the court apply?

Note 2. For what purpose does the court cite *Lyons v. Airdyne* (*718), and what's the deeper issue at stake?

Note 3. Transferred intent doctrine. Changing the facts of this case, if Mr. Derouen had intended to make contact with Mr. Jones, but accidentally hit Mr. Villa, the rules of intent would still have allowed Mr. Villa to bring a lawsuit. Under the doctrine of "transferred intent," a defendant cannot escape liability by having the good luck to have bad aim. Indeed, the presumption is that had he hit Mr. Jones, Mr. Jones would have been the plaintiff instead. The doctrine, which has its origins in the writ system, has two aspects. First, if a defendant **meets the requisite intent with respect to one person**, but the effect of the conduct instead invades the interest of another, **the required intent "transfers"** from that intended person to the person actually wronged. Second, if a defendant **meets the requisite intent for any of the core intentional torts** (battery, assault, false imprisonment, trespass to chattels, or trespass to land), it can be **transferred** to satisfy the intent of any of the others. It does not apply to IIED (or to conversion, a tort related to personal property not covered in this casebook). In other words, the defendant does not escape liability by explaining that they merely meant to trespass on your property, but not to affect your chattels in anyway, or by explaining that they merely meant to frighten you into thinking they were about to harm, not to actually harm you, once they actually do commit a battery. If they meet the intent requirement for assault, it can be transferred to battery.

Note 4. Practice Stating the Rule. Notes and questions following assigned cases have focused thus far on formulating the legal question and holding but have not yet routinely asked you to formulate the "rule" of a case. Sometimes the rule is synonymous with the holding but often it's not. The rule tends to be the principle for which the case will be cited (and there may be more than one rule, too). Discovering the rule requires skill that you will develop over time, as well as flexibility. Often the rule can be expressed in different ways, which may seem frustrating for those seeking a single correct answer, and sometimes the full scope of the rule will take subsequent cases to discern and develop

fully. Recall how the holding in *Davison* altered slightly in *Bartlett's* application of it, for example. Courts may *later* read a case for a certain proposition although that case never originally came out and announced its rule in that way. Consider how *Guille v. Swan* is now routinely understood as a paradigmatic strict liability case when at the time it was analyzed in terms of trespass. The rule as initially announced versus the rule as enduring principle that may eventually have lasting importance in the field can require some time to discern. This is why it is crucial to understand how rules evolve, how the facts and policies at play can both yield to and change rules over time. It helps lawyers to decode and predict the law, or at least to anticipate certain kinds of changes. That the rule can be expressed in different ways, or that multiple rules can exist does not relax the need for precision. Formulating the rule still requires precision. Practice stating the rule, or 1 or two of the most significant rules you see in *Villa*.

Note 5. Note that the court raises Mr. Villa's accent (and ethnicity) in its own footnote. Consider why it might have done so, and the possible effects on future courts and trials. Does the reference seem to hurt or help (and whom, and why)? According to the authors of a leading torts casebook, the court may have mentioned his ethnicity because Villa's attorney, Charles L. Porter, believed that Villa was a victim of racial harassment. Villa, a Dominican man, was dating an African-American woman and his white Cajun fellow employees apparently found this objectionable and harassed him for it. "Villa's attorney, now a state judge in Louisiana, raised this issue at trial, but the predominantly white, Cajun jury did not seem to respond well so he concentrated instead on the elements of the battery charge." (Interview with Charles L. Porter, plaintiff's attorney, July 18, 2001. Ibrahim J. Gassama, Lawrence C. Levine, Dominick Vetri and Joan E. Vogel, *Tort Law and Practice*, Fifth Edition (Carolina Press, 2016), p. 703.

The Restatement provided an additional way to define intent: **knowledge, coupled with "substantial certainty"** that consequences will follow. If you tossed a ball in the air near someone sleeping on the grass nearby and you knew "to a substantial certainty" that the consequence would be that the ball would strike that person, you *intended* to strike that person for the purposes of tort liability. In some cases, this distinction makes little difference, but in others it adds nuance that the court might find helpful or even dispositive. It is often easier to determine whether someone knew something (or could be expected to know something, because of their age or mental state or ability) than whether they *intended* something.

A classic mistake is finding *no* intent unless there is evidence of **specific intent**, which again means the **intent to produce the harm that happened**. After all, you could toss a ball at someone, fully intending to do that but imagining that your ball will land very lightly and be received in the spirit of good humor. But you could discover that your ball actually dealt a crushing blow and broke bones (perhaps because you were unaware of an underlying condition like brittle bones, or because you were genuinely unaware of your own strength). Nonetheless, for tort law, you intended to make contact and that is all that is needed. Trying to negate intent by explaining that you "didn't *intend* to break anybody's bones" will do no good—that would be elevating the intent standard from intent to make contact to intent to bring about the harm that occurred from that contact. The former is the ordinary (or "purpose") intent standard (intent to make contact) and the latter is "specific intent" which is not required (intent to produce the harm that occurred).

The next case provides an example of an application of the Restatement's "knowledge to a substantial certainty."

**WMEL Water and Sewer Authority et al v. 3M, U.S. Dis. Ct. N.D. Ala. (2016)
(208 F. Supp.3d 1227)**

The plaintiffs in this case are West Morgan-East Lawrence Water and Sewer Authority (the “Authority”), in its individual capacity, and Tommy Lindsey, Lanette Lindsey, and Larry Watkins (collectively “Representative Plaintiffs”), who bring this action both individually and on behalf of a class of persons similarly situated.²⁰ [***] The Authority and Representative Plaintiffs (collectively “Plaintiffs”) assert common law claims of negligence (Count I), nuisance (Count II), abatement of nuisance (Count III), trespass (Count IV), battery (Count V), and wantonness (Count VI) against 3M Company, Dyneon, L.L.C., and Daikin America, Inc. Currently before the court is 3M and Dyneon’s motion to dismiss the amended complaint pursuant to Federal Rule of Civil Procedure 12(b)(6). [***]

This action arises out of defendants’ discharge of wastewaters containing perfluorooctanoic acid (PFOA), perfluorooctanesulfonic acid (PFOS), and related chemicals into the Tennessee River near Decatur, Alabama. Specifically, 3M and its wholly-owned subsidiary Dyneon own and operate manufacturing and disposal facilities in Decatur, which have released, and continue to release, PFOA, PFOS, and related chemicals into ground-and surface water, through which the chemicals are ultimately discharged into the Tennessee River. Daikin America manufactures tetrafluoroethylene and hexafluoropropylene fluoropolymers, produces PFOA as a byproduct, and discharges PFOA, PFOS, and related chemicals into the Decatur Utilities Wastewater Treatment Plant. The Wastewater Treatment Plant, in turn, discharges the wastewater into the Tennessee River.

***1232** Defendants discharge these chemicals thirteen miles upstream from the area where the Authority draws water that it supplies to local water utilities, or directly to consumers. Although the Authority treats the water, unsafe levels of PFOA and PFOS remain in the drinking water because of these chemicals’ stable carbon-fluorine bonds and resistance to environmental breakdown processes. Studies, including one by an independent science panel, have shown that absorption of these chemicals may cause long-term physiologic changes and damage to the blood, liver, kidneys, immune system, and other organs, and an increased risk of developing cancer, immunotoxicity, thyroid disease, ulcerative colitis, and high cholesterol.

Plaintiffs allege that defendants continue to discharge these chemicals into the Tennessee River despite knowing of the persistence and toxicity of PFOA and PFOS. Further, defendants are aware that tests of the Authority’s treated water have shown elevated levels of these chemicals. The Authority has consistently found PFOA levels at 0.1 ppb and PFOS levels at 0.19 ppb in its treated water, where 0.07 ppb is the current [Fn] EPA Health Advisory Level for both of those chemicals. As a result of these levels, the Authority has incurred costs of testing its treated water, implementing pilot programs to develop more effective methods for the removal of PFOA and PFOS, and attempting to locate a new water source.

Representative Plaintiffs and the proposed class are owners or possessors of property who consume water supplied by the Authority and other water utilities that receive water from the Authority. at 2. They allege personal injuries from their exposure to unsafe levels of PFOA and PFOS in their domestic

²⁰ The proposed class consists of “all owners and possessors of property who use water provided by the West Morgan-East Lawrence Water and Sewer Authority, the V.A.W. Water System, the Falkville Water Works, the Trinity Water Works, the Town Creek Water System, and the West Lawrence Water Cooperative.”

water supplies, including elevated levels of those chemicals in their blood serum. In 2010, the federal Agency for Toxic Substances and Disease Registry (“ATSDR”) analyzed the blood serum of 121 customers of the Authority, including some of the Representative Plaintiffs and members of the proposed class, for PFOA and PFOS, and found an association between elevated levels of those chemicals and the use of drinking water supplied by the Authority. In addition to personal injuries, Representative Plaintiffs and the proposed class claim diminution in their real property values, and out-of-pocket costs for purchasing water filters and bottled water.

[*] E. Battery (Count V)**

To state a claim for battery under Alabama law, a plaintiff must establish that: (1) the defendant touched the plaintiff; (2) the defendant intended to touch the plaintiff;²¹ and (3) the touching was conducted in a harmful or offensive manner. [cc] Rest. (2d) of Torts § 18 (1965)). Representative Plaintiffs and the proposed class allege that defendants “touched or contacted” them “through their release of PFOA, PFOS, and related toxic chemicals” into plaintiffs’ water supply. Those plaintiffs further allege that defendants “knew that their intentional acts would be substantially certain to result in such contact,” and that such touching or contact “was and is harmful and offensive.”

1. Lack of physical injury

Defendants raise three arguments in support of their motion. First, they argue that plaintiffs have suffered no manifest physical injury. This contention is unavailing, because a claim for battery in Alabama does not require an actual injury to the body as an element of the claim. [cc]

2. Consent to the touching or contact

Second, defendants contend that dismissal is warranted because plaintiffs consented to the contact by voluntarily drinking the water. Plaintiffs claim that they did not “consent to their ingestion of and exposure to these toxic chemicals,” and, alternatively, allege that “consent is at most an affirmative defense to this claim that presents factual issues that cannot be resolved on a motion to dismiss.” [c] Indeed, it is apparent from the face of the amended complaint that Representative Plaintiffs and the proposed class use water filters or buy bottled water now, and once, voluntarily consumed the water prior to learning of the contamination. Thus, the question this court must resolve is whether the voluntary ingestion of water from the Authority (at least before they learned of the contamination) constitutes consent to the ingestion of the contaminants in the water. Because defendants failed to cite any Alabama law that suggests that plaintiffs’ consumption *1237 of the water constituted consent to their uninformed ingestion of PFOA and PFOS, the court will defer addressing this issue until the summary judgment stage.

3. Intent

Finally, defendants contend that dismissal is warranted on the battery claim because defendants did not specifically intend to touch or contact plaintiffs. Intent can be satisfied by substantial certainty [c] Plaintiffs allege that defendants are aware that they discharge PFOA and PFOS into the water, and that they know those chemicals appear at harmful levels in the treated water sold by the Authority. These facts are sufficient to give rise to a reasonable inference that defendants discharge PFOA and PFOS

²¹ A plaintiff can establish “intent” by showing that the defendant “desires or is *substantially certain* of the injury to result from his or her act.” [c]

into the Tennessee River with substantial certainty that the water will be used for drinking and other household purposes.

For all these reasons, the motion to dismiss the battery claim is due to be denied.

[***] For the reasons stated above, 3M and Dyneon’s motion to dismiss is [***] as to ...battery (Count V) [and other omitted] claims, and plaintiffs may proceed ..., with the understanding that they may not pursue a private nuisance claim or negligence claims based on personal injuries. The court will reserve ruling on the sufficiency of the class allegations until a later date.

Note 1. Is the knowledge intent standard necessary to the battery claim on these facts? Could a purpose intent standard have worked as well? What sort of evidence do you think plaintiffs would need to show in proving either kind of intent? Is the difference one of kind or of degree?

Note 2. Tort law is one of the tools in environmental advocacy, whether it takes the shape of impact litigation, class actions or doctrinal developments to permit certain sorts of lawsuits. Professor Sanne Knudsen has written on the way that chemical latency could frustrate tort law’s causation requirement, for instance, and advocated the development of causation frameworks that can account for the complexities of what she has called “long-term torts” with significant ecological harms. Sanne H. Knudsen, *The Long-Term Tort: In Search of a New Causation Framework for Natural Resources Damages*. 108 Nw. U. L. Rev. 475 (2014), <https://digitalcommons.law.uw.edu/faculty-articles/15/>

Given what you know about the purposes of tort law and its capacities for change over time, does tort law seem like a good vehicle for achieving greater environmental justice? What do you imagine are the drawbacks, limits and costs of using tort law in this way?

Note 3. The court acknowledges that consent could defeat the plaintiffs’ claim because members of the class voluntarily drank polluted water; it will require resolution at a later date and this litigation is still unresolved. What do you think descriptively and normatively of this concept of consent?

Variations in Mental State

Another complexity in the determination of intent is that certain states of mind can negate intent though it’s not always intuitive which ones. Mental illness or disability does *not* negate intent so long as the defendant had the capacity to form the requisite intent (which is a question of fact for the jury). However, early case law is often not very nuanced in assessing mental states. Some cases may refer to people with mental illness or disabilities as “deficient” or abnormal or worse. It is worth paying attention to how advances in psychology make both the rhetoric and the substance of tort law more equitable over time. Being a child does not necessarily negate intent; the question will depend on how the jurisdiction treats youths and what we can determine about what they know.

Being drugged against one’s will most likely negates intent for everything that follows or a good deal of it, given that your powers of volition will be severely impaired. But being drunk does not negate intent. Nor does being mistaken about the facts; if you pick up a very lifelike-looking toy gun believing it to be a gun and try to shoot someone, your actions are no less culpable for the fact that you were mistaken about the status of the gun. This is different from bad aim or an intent to act that produces a different outcome from the particular one intended, which arose above in discussion of the **doctrine**

of transferred intent. Transferred intent applies only to the intent necessary for five torts: battery, assault, false imprisonment, trespass to land and trespass to chattels.

Check Your Understanding (2-2)

Question 1. True or false: Genuine mistakes are often a means of negating intent for the purposes of finding an intentional tort.

An interactive H5P element has been excluded from this version of the text. You can view it online here: <https://saidtorts2d.lawbooks.cali.org/?p=38#h5p-29>

Question 2. An epileptic has a sudden, violent seizure during church and, without warning, she knocks a smaller, frail individual seated next to her to the ground. He sues. What theory is likeliest to be most successful for him, and why?

An interactive H5P element has been excluded from this version of the text. You can view it online here: <https://saidtorts2d.lawbooks.cali.org/?p=38#h5p-30>

Question 3. Which of the following facts, if true would most likely change the outcome of *Villa v. Derouen* (the pressurized oxygen coworker case)?

An interactive H5P element has been excluded from this version of the text. You can view it online here: <https://saidtorts2d.lawbooks.cali.org/?p=38#h5p-31>

Classmate's Kick Hypothetical: A twelve year-old boy, Abe, kicks another boy, Ed, while they are seated in their classroom. The kick makes contact with Ed's kneecap which has, unbeknownst to Abe, a particular sensitivity. The kick causes intense damage and ensuing infection. Abe feels bad, but protests that he never intended this kick to hurt, and besides, he had no idea about Ed's hidden condition. Abe's father, who went to the same school as these young boys, and remembers fond games of tackle football with Ed's father, says he is sure he has seen these boys wrestling on the playground before. How is this any different, he asks. He thinks that boys need to be able to engage in physical activity and roughhousing and this would be a ridiculous thing to sue over; can't they laugh it off? Two surgeries later, Ed and his family aren't laughing.

How would you use the rule you formulated in *Villa* to address this hypothetical? Or, if your rule(s) do not seem to govern this case, practice creating a new, descriptively accurate statement of law that analogizes or distinguishes this fact pattern from *Villa*.

Note 1. Eggshell Plaintiff or Thin Skull Plaintiff Doctrine. This hypothetical is loosely based on the facts of *Vosburg v. Putney*, a classic torts case which stands for several points of law (including on intent, context for conduct, and damages) (50 N.W. 403, Wis.) (1891). With respect to damages, it holds that just because the *amount* of harm was unexpected, the defendant is no less liable if their conduct otherwise satisfies the element of the tort. Sometimes known as the eggshell plaintiff or “thin skull” plaintiff doctrine, this principle predates *Vosburg* but is often cited in connection with it. The doctrine holds that the defendant “takes their plaintiff as they find them.” If a plaintiff has a thin, more easily injured skull, that may not be apparent to the defendant yet the defendant will still be liable for the extra damages this particular plaintiff suffers so long as the defendant’s conduct met the elements of the tort in question. Even if a plaintiff is extraordinarily susceptible to harm (they have brittle bones or for whatever reason the harm they suffer from the tortious conduct is worse than another plaintiff’s would have been), this doctrine makes it the *defendant’s*, not the *plaintiff’s* problem to resolve. Note that the eggshell doctrine does not only apply to pre-existing conditions; it can apply to a predisposition towards suffering worse harm or an unfortunately worse outcome. The standard for harm is thus not “objective” (what would a reasonable person’s injuries have been under the circumstances”) but “subjective” (what did *this person* actually suffer, on account of the defendant’s misconduct)?

In *Smith v. Leech Brain & Co.*, 2 Q.B. 405 (1962), the plaintiff, William Smith, was injured at work when his employer failed to provide adequate safeguards to prevent injury in the presence of molten metal. Smith sustained a serious burn on his lip from a spattering of molten metal, and while only the lip was burned, the wound failed to heal. Smith eventually developed cancer at the point of the burn which caused his death. His wife sued for damages and won. The court rejected the defendant’s arguments that the damages suffered were out of proportion to the harm by the defendant. Though that was a negligence case, it illustrates the application (in all domains of tort law) of the eggshell plaintiff rule.

Note 2. One scholar explores the use of the eggshell plaintiff doctrine to deal with pre-existing conditions that are not *created* by new tortious conduct but significantly *worsened* by it. Dean Camille Nelson analyzes when courts have used the doctrine in service of corrective justice, and considers its analogous use to redress harms to women and people of color for whom pre-existing traumas or particular conditions might be triggered or worsened by tortious conduct:

“The extent to which the Thin skull doctrine has been stretched is evidenced by the case of *Warren v. Scruttons Ltd.*²² The plaintiff had a pre-existing ulcer on his left eye when he cut his finger on a wire on the defendant’s equipment. The wire apparently had a type of chemical on it, described as “poison,” which led the plaintiff to contract a fever and a virus. This resulted in further ulceration of the eye. The defendant was found liable and the court held that, “any consequence which results because the particular individual has some peculiarity is a consequence for which the tortfeasor is liable.”²³ In terms of equality arguments,²⁴ women have been compensated for injuries

²² *Warren v. Scruttons Ltd.*, (1962) 1 Lloyd’s Rep. 497 (Q.B.D.).

²³ *Id.* at 502.

²⁴ See Dennis Klimchuk, *Causation, Thin Skulls and Equality*, 11 Can. J.L. & Juris. 115 (1998) (advocating for the entrenchment of tort-like Thin skull principles in criminal law). Where, for instance, a victim is stabbed, loses [sic] a significant amount of blood, denies a blood transfusion on religious grounds and dies, Klimchuk states that the thin-

specific to our sex. For instance, the Thin skull doctrine has been applied to compensate pregnant women who have suffered miscarriages or who have had stillborn children.²⁵ Similarly, where a woman whose ovaries were weakened by a previous operation suffered injury as a result of a sudden stoppage of a train, the court granted recovery on the basis that “the weak will suffer more than the strong.”²⁶ If sex does not present a bar to recovery based upon particular vulnerabilities, why should race? Race-related, or racism-related mental disorders, might similarly be infused into the Thin-skull doctrine as it has generally allowed for recovery based upon such mental vulnerabilities. Alternatively, this might more properly justify consideration of the Eggshell personality doctrine. If a physical injury triggers mental suffering or nervous disorders, the defendant must pay the resultant damages, even if they are more serious than might be expected.²⁷ If, however, there is a pre-existing mental condition rendering the plaintiff particularly vulnerable, courts may still allow recovery, thus transforming the thin-skull plaintiff into one a plaintiff with an eggshell personality.

Camille A. Nelson, *Considering Tortious Racism*, 9 DePaul J. Health Care L. 905, 960–61 (2005)

Note 3. Having read about the eggshell plaintiff and begun to consider its possible extensions and limits, revisit your understanding of intent. Might it make sense to apply the eggshell plaintiff doctrine only in cases in which there was a particular intent level, such as specific intent to harm? What is the effect of its applicability to not just intentional torts but negligence? Which of tort law’s purposes is most apparently driving the robust application of this doctrine?

Check Your Understanding (2-3)

Question 1. Which of the following statements is true of the eggshell plaintiff doctrine:

An interactive H5P element has been excluded from this version of the text. You can view it online here: <https://saidtorts2d.lawbooks.cali.org/?p=38#h5p-32>

skull rule should allow for the finding of proximate cause –to do otherwise would violate principles of equality. The defendant should be found culpable for the death of the victim.

²⁵ *Malone v. Monongahela Valley Traction*, 104 Va. 417 (1927); *Schafer v. Hoffman*, 831 P.2d 897 (1992).

²⁶ *Linklater v. Minister for Railways*, [1900] 18 N.Z.L.R. 526, 540.

²⁷ *Linden*, supra note 236, at 330. Linden points out that in a case involving the claim for mental suffering by a plaintiff as a result of being thrown against a seat of a streetcar when it collided with a train, the Supreme Court of Canada recognized that the “nervous system is as much a part of a man’s physical being as muscular or other parts.” *Toronto Railway Co. v. Toms*, 44 S.C.R. 268, 276 (1911). *Vargas v. John Labatt Ltd.*, [1956] O.R. 1007.

Expand On Your Understanding – Intent Hypotheticals

Review the following hypotheticals, which feature various forms of violence to the body as a means of testing the scope of the intent requirement. The questions are designed both to test some of the rules you already know as well as to add to your understanding. Do not feel too concerned if you are learning some rules for the first time in addition to testing and reaffirming some rules you have already learned. Turn each card to reveal the answer.

An interactive H5P element has been excluded from this version of the text. You can view it online here: <https://saidtorts2d.lawbooks.cali.org/?p=38#h5p-33>

Chapter 8. Revisiting Assault and Battery

Assault: Elements

- Action, or threat of an action, performed with
- Intent, that
- Creates in the plaintiff a reasonable apprehension of
- Imminent bodily harm

Battery: Elements

- Unauthorized bodily contact by the defendant, which is
- Harmful or offensive in nature, and performed with
- Intent to make contact

Exam Tip: When you see a battery claim, look for an assault claim. Sometimes they travel together; sometimes the fact pattern expressly triggers one claim but not the other, say because a plaintiff was not ever touched (no battery) even if they were threatened with imminent harm or because a plaintiff was touched in an offensive way but was not awake or aware during the time (no assault).

I de S et ux. v. W de S, At the Assizes (1348)

I de S and M, his wife, complain of W de S concerning this, that the said W, in the year, etc., with force and arms did make an assault upon the said M de S and beat her. And W pleaded not guilty. And it was found by the verdict of the inquest that the said W came at night to the house of the said I and sought to buy of his wine, but the door of the tavern was shut and he beat upon the door with a hatchet which he had in his hand and the wife of the plaintiff put her head out of the window and commanded him to stop, and he saw and he struck with the hatchet but did not hit the woman. Whereupon the inquest said that it seemed to them that there was no trespass since no harm was done. THORPE, C.J. There is harm done and a trespass for which he shall recover damages since he made an assault upon the woman as has been found, although he did no other harm. Wherefore tax the damages, etc. And they taxed the damages at half a mark. Thorpe awarded that they should recover their damages, etc., and that the other should be taken. And so note that for an assault a man shall recover damages, etc.

Note 1. Prior to this case, the law was uncertain on the question of whether an action could succeed if the defendant's actions hadn't caused physical harm (what we now know as a battery). The tavern owner and his wife lost before "the inquest" (the equivalent of the lower court) and appealed to the courts of assize (England's traveling courts, which were organized into six judicial circuits). There the plaintiffs won. The case is credited with being the origins of the tort of assault.

Note 2. In some instances, such as this case, an assault may lie when an attempted battery has failed to make contact with the plaintiff. However, there does not *need* to be an attempted battery for a plaintiff to make out a successful claim. Revisit the elements of assault and battery, below. Can you imagine instances in which there is a clear case of assault and just as clearly no case of battery?

Hypothetical: the Zany Meat Inspector

Ibrahim, an employee of Meatpacking Company, Inc., sustained serious injuries to his mouth as a result of the actions of Peter, a meat inspector for the United States Department of Agriculture. A truck shipment of beef arrived at the receiving dock of Meatpacking Co's plant. Ibrahim was one of the employees assigned to unload this truck. While doing so, he was suddenly and without warning jumped by Peter, the inspector (whom he knew as a friend in the industry and former co-worker). Peter screamed "Boo!", pulled Ibrahim's wool stocking hat over his eyes, climbed onto his back and began to ride him piggyback. As a result of this prank, Ibrahim fell forward and struck his face on some meat hooks located on the receiving dock. Consequently, he suffered severe injuries to his mouth and teeth.

Is this an intentional tort or negligence, and why?

Assuming the former, how would you analyze the intent issue?

Reynolds v. MacFarlane, Utah Appellate Court (2014) (322 P.3d 755)

John Reynolds appeals from the trial court's dismissal of his intentional tort claims against Bret MacFarlane. We affirm in part, reverse in part, and remand to the trial court.

On August 5, 2009, MacFarlane walked into the break room at his workplace where his coworker, Reynolds, was standing in front of the microwave oven. Reynolds was holding a ten dollar bill somewhat loosely in his hand. Reynolds was unaware of MacFarlane's presence. MacFarlane approached Reynolds from behind and, without touching Reynolds, quickly snatched the ten dollar bill. Reynolds immediately spun around and faced MacFarlane. MacFarlane then stated, "That was too easy," and returned the ten dollar bill to Reynolds. As MacFarlane began to walk away, Reynolds struck MacFarlane, splitting his lip. MacFarlane asked why he hit him. Reynolds replied, "You pissed me off." Shortly after this incident, the two interacted with a larger group of employees outside, and the employees joked around and completed their break. The two men were together at an offsite employee lunch some days later, and on multiple occasions after the incident Reynolds sought out and voluntarily spoke with MacFarlane in MacFarlane's work area.

Nevertheless, the incident was reported to the parties' supervisor. During the ensuing investigation, Reynolds reported to the supervisor that the incident was "nothing" and that any contact between the parties was accidental. Reynolds was ultimately punished with a one-day suspension without pay for striking another employee. Thereafter, Reynolds received medical treatment for anxiety, which Reynolds explained to his physician had resulted from difficulties at work.

Nearly one year later, Reynolds filed a complaint against MacFarlane, alleging assault and intentional infliction of emotional distress. At a bench trial, the parties stipulated to the dismissal of Reynolds's claim for intentional infliction of emotional distress, but Reynolds moved to amend his complaint to include a claim for battery. The court granted Reynolds's motion. After hearing the evidence, the trial court found MacFarlane "to be more credible in that [his] testimony was more consistent and was corroborated by multiple parties." Accordingly, the court based its findings of fact largely on MacFarlane's testimony. The trial court concluded that Reynolds had not met his burden of proof to show that MacFarlane had committed an assault or a battery against him and then dismissed the case with prejudice. Reynolds appeals.

I. Assault

Reynolds challenges the trial court's conclusion that he failed to prove assault. As an appellate court, we give great deference to the trial court's role as a fact finder and will review its findings of fact only for clear error. [c] We review the trial court's legal conclusions for correctness. [c] *758 To the extent that Reynolds challenges the trial court's findings of fact, he merely reargues the evidence in favor of his position and does not adequately marshal the evidence supporting the trial court's findings as required by our rules of appellate procedure. *See* Utah R.App. P. 24(a)(9) ("A party challenging a fact finding must first marshal all record evidence that supports the challenged finding."). Because of this failure to marshal, we accept the facts as articulated by the trial court. [c]

Under Utah law, "[a]n assault is an act '(a) ... intending to cause a harmful or offensive contact with the person of the other ... or an imminent apprehension of such a contact' by which '(b) ... the other is ... put in such imminent apprehension.'" *Tiede v. State*, 915 P.2d 500, 503 n. 3 (Utah 1996) (omissions in original) (quoting Restatement (Second) of Torts § 21 (1965)). The trial court concluded that Reynolds could not prevail on his assault claim for three reasons. First, the trial court determined that Reynolds failed to establish that he was in imminent apprehension of harmful or offensive contact because he was not aware of MacFarlane's presence until after he spun around to find out who had taken his ten dollar bill. Second, the trial court ruled that even though MacFarlane intended to take the ten dollar bill, MacFarlane did not intend to cause imminent apprehension of harmful contact in Reynolds by doing so. Third, the trial court ruled that Reynolds suffered no injury or damages as a result of MacFarlane's actions. Reynolds challenges each of these conclusions. We need address only Reynolds's first challenge because it is dispositive to our conclusion that the trial court correctly determined that Reynolds failed to prove that an assault occurred.

Reynolds concedes that a plaintiff complaining of assault "must be aware of the defendant's act." *See* W. Page Keeton et al., *Prosser and Keeton on the Law of Torts* § 10, at 44 (5th ed.1984) ("Since the interest involved is the mental one of apprehension of contact, it should follow that the plaintiff must be aware of the threat of contact, and that it is not an assault to aim a gun at one who is unaware of it."). In Reynolds's view, this requirement is satisfied in this case because he "was keenly aware of what happened to him" "the moment the money was snatched from his hand."

However, a plaintiff complaining of assault cannot be in apprehension of harmful or offensive contact unless he is aware of such contact *before* the threat of the contact is accomplished or has dissipated. "The plaintiff's subjective recognition or apprehension that [he] is about to be touched in an impermissible way is at the core of [an] assault claim." 1 Dan B. Dobbs et al., *The Law of Torts* § 38, at 97 (2d ed.2011). As section 22 of the Restatement explains, "An attempt to inflict a harmful or

offensive contact or to cause an apprehension of such contact does not make the actor liable for an assault if the other does not become aware of the attempt before it is terminated.” Restatement (Second) of Torts § 22 (1965); *see also id.* § 22 cmt. a (“[T]he defendant is not liable if his efforts to inflict the bodily contact have been abandoned or frustrated before the other is aware of them, since in such case the other is not put in the required apprehension.”). Reynolds has directed us to no authority to the contrary.

As a result, we conclude that the trial court correctly ruled that Reynolds was not in imminent apprehension of harmful or offensive contact because he was not aware of MacFarlane’s presence until after MacFarlane took the ten dollar bill from Reynolds’s hand. ... Accordingly, Reynolds did not prove that MacFarlane committed an assault against him, and the trial court correctly dismissed his assault claim.

II. Battery

Reynolds also challenges the trial court’s determination that he failed to establish the elements of a battery. We review *759 the trial court’s legal conclusions for correctness. [c] Utah has adopted the Restatement (Second) of Torts to define the elements of the intentional tort of battery. *Wagner v. State*, 2005 UT 54, ¶ 16, 122 P.3d 599. Consequently, an actor is liable for battery if “(a) he acts intending to cause a harmful or offensive contact with the person of the other ... or an imminent apprehension of such a contact, and (b) a harmful contact with the person of the other directly or indirectly results.” *Id.* (quoting Restatement (Second) of Torts § 13 (1965)).

In this case, the trial court found that MacFarlane did not touch Reynolds when he grabbed the ten dollar bill from Reynolds’s hand. Because “MacFarlane never touched or came into contact with Reynolds,” the trial court concluded that Reynolds did not meet his burden of proof to show that a harmful contact resulted from MacFarlane’s action.²⁸ Reynolds asserts that the trial court’s conclusion is erroneous because MacFarlane’s grabbing of an object—the ten dollar bill—from his hand was sufficient contact with his person to constitute a battery.

For the intentional tort of battery, harmful or offensive contact “includes all physical contacts that the individual either expressly communicates are unwanted, or those contacts to which no reasonable person would consent.” *Id.* ¶ 51. But “it is not necessary that the plaintiff’s actual body be disturbed.” Restatement (Second) of Torts § 18 cmt. c (1965). Rather, “[p]rotection of the interest in freedom from intentional and unpermitted contacts with the plaintiff’s person extends to any part of the body, or to anything which is attached to it and practically identified with it.” W. Page Keeton et al., *Prosser and Keeton on the Law of Torts* § 9, at 39 (5th ed.1984) (footnote omitted). “Thus, if all other requisites of a battery against the plaintiff are satisfied, contact with the plaintiff’s clothing, or with a cane, a paper, or any other object held in the plaintiff’s hand, will be sufficient” to support a battery claim because the “interest in the integrity of [a] person includes all those things which are in contact or connected with the person.” *Id.* § 9, at 39–40 (footnotes omitted); *** *Fisher v. Carrousel Motor Hotel, Inc.*, 424

²⁸ The trial court explained,

Reynolds cited case law from other jurisdictions holding that the intentional snatching of an object from one’s hand could constitute an offensive invasion of one’s person, so as to constitute an actual, physical contact. However, the Court concludes that Utah has not so extended the definition of battery to include such actions as actual contact. If the law in Utah were to be so extended, the Court’s findings would give rise to a battery by MacFarlane.

S.W.2d 627, 629 (Tex.1967) (“The intentional snatching of an object from one’s hand is as clearly an offensive invasion of his person as would be an actual contact with the body.”). *But see Workman v. United Fixtures Co.*, 116 F.Supp.2d 885, 896–97 (W.D.Mich.2000) (concluding that even if the defendant removed a paper from the plaintiff’s hand, “nothing in the record suggests that [the defendant’s] alleged actions amounted to an offensive contact battery”). We consider the above authorities as persuasive and not inconsistent with our supreme court’s battery analysis.

In this case, MacFarlane’s act of taking the ten dollar bill held loosely in Reynolds’s hand was sufficient contact to constitute the contact element of battery, *see Wagner*, 2005 UT 54, ¶ 16, 122 P.3d 599, notwithstanding the fact that MacFarlane did not touch Reynolds’s body. When held in his hand, the ten dollar bill was connected to Reynolds such that when MacFarlane snatched the bill from Reynolds, MacFarlane’s act resulted in offensive contact with Reynolds’s person. The intent element of battery was also met in this case because *760 the trial court found that MacFarlane intended to take the bill from Reynolds’s hand when he acted. *See id.* ¶ 29 (“[T]he only intent required to commit a battery is the intent to make a contact, not an intent to harm, injure, or offend through that contact.”). Accordingly, we conclude that the trial court erred in dismissing Reynolds’s battery claim because the court’s factual findings establish both elements of the claim.

The trial court determined that Reynolds suffered no damages as a result of the August 5, 2009 incident. The Utah Supreme Court has explained that “[a] harmful or offensive contact is simply one to which the recipient of the contact has not consented either directly or by implication.” *Id.* ¶ 51. “[H]armful or offensive contact is *not limited to that which is medically injurious* or perpetrated with the intent to cause some form of psychological or physical injury.” *Id.* (emphasis added). Instead, harmful or offensive contact “includes all physical contacts that the individual either expressly communicates are unwanted, or those contacts to which no reasonable person would consent.” *Id.* Moreover, “[c]ommon law battery does not require that the nonconsensual contact be injurious. Rather, proof of an unauthorized invasion of the plaintiff’s person, even if harmless, *entitles him to at least nominal damages.*” *Lounsbury v. Capel*, 836 P.2d 188, 192–93 (Utah Ct.App.1992) (emphasis added); *see also id.* at 196 (“[A plaintiff] need not prove injury to sustain his battery claim; if he proves no more than the ‘offense’ of the nonconsensual touching, he is entitled to nominal damages.”); Keeton et al. § 9, at 41 (“[T]he defendant is liable not only for contacts which do actual physical harm, but also for those relatively trivial ones which are merely offensive and insulting.”). “Damages for pain, suffering, ‘psychological problems’ and the like, however, may ... be recovered only to the extent that [the plaintiff] proves they were a proximate result” of the nonconsensual touching. *Lounsbury*, 836 P.2d at 196.

Here, the trial court found that “no injury resulted to Reynolds as a direct and proximate cause of MacFarlane’s actions.” Thus, the trial court ruled that Reynolds’s claimed damages—the one-day suspension and his medical issues following the break-room incident with MacFarlane—were not proximately caused by MacFarlane’s act. Reynolds has not effectively challenged this ruling on appeal. However, because we have concluded that MacFarlane committed a battery, Reynolds is entitled to nominal damages. *See id.* at 192–93 (“[U]nauthorized invasion of the plaintiff’s person, even if harmless, entitles him to at least nominal damages.”). Accordingly, we remand to the trial court for an award of nominal damages to Reynolds for battery.

III. Attorney Fees

¶ 18 MacFarlane requests an award of attorney fees incurred on appeal, pursuant to rule 33 of the Utah Rules of Appellate Procedure. MacFarlane argues that Reynolds’s appeal in this matter is frivolous and asserts that he is therefore entitled to attorney fees.

¶ 19 “[I]f the court determines that a[n] ... appeal taken under these rules is either frivolous or for delay, it shall award just damages, which may include ... reasonable attorney fees, to the prevailing party.” Utah R.App. P. 33(a). A frivolous appeal “is one that is not grounded in fact, not warranted by existing law, or not based on a good faith argument to extend, modify, or reverse existing law.” *Id.* R. 33(b). Because we reverse the trial court’s ruling on one of the issues raised, Reynolds’s appeal is clearly not frivolous. We therefore decline to award MacFarlane the attorney fees that he has incurred on appeal.

In sum, the trial court correctly concluded that Reynolds did not establish the elements of assault, because Reynolds was not aware of MacFarlane’s imminent contact. We affirm the dismissal of Reynolds’s assault claim, reverse the dismissal of Reynolds’s battery claim, and remand to the trial court for judgment in favor of Reynolds on his battery claim and for an award of nominal damages.

Note 1. Given that Reynolds was awarded only nominal damages, do you imagine it was still worth the lawsuit? Why or why not?

Note 2. Is it an assault to point a toy gun at someone’s head? How about a real gun that is unloaded? How about a loaded gun that one brandishes in the air near another person’s head, carelessly, saying, “don’t worry, I’m not going to shoot you”? Ground your answers in the elements of assault.

Note 3. An early case held that it was correct to find an assault had been committed when a defendant aimed an unloaded gun at the plaintiff and pulled the trigger twice, frightening the victim who was unaware the gun was unloaded. The court explained its ruling thus:

One of the most important objects to be attained by the enactment of laws and the institutions of civilized society is, each of us shall feel secure against unlawful assaults. Without such security society loses most of its value. Peace and order and domestic happiness, inexpressibly more precious than mere forms of government, cannot be enjoyed without the sense of perfect security. We have a right to live in society without being put in fear of personal harm. But it must be a reasonable fear of which we complain. And it surely is not unreasonable for a person to entertain a fear of personal injury, when a pistol is pointed at him in a threatening manner, when, for aught he knows, it may be loaded, and may occasion his immediate death. The business of the world could not be carried on with comfort, if such things could be done with impunity. *Beach v. Hancock*, 27 N.H. 223, 229–30 (1853).

Note 4. Who should decide whether a person’s fear, or “anticipation of imminent bodily harm” is reasonable? Is this an objective or subjective standard, *descriptively* and which should it be, *normatively*, in your view?

Note 5. Consider Dean Nelson’s earlier application of the “thin skull” doctrine to women and people of color. Are there normative justifications for tailoring harms to account of societal imbalances, such as sexism, racism, and other structural inequalities? How about arguments against doing so because of

the value of not unsettling the law? Is there a way to be anti-racist, or progressive in other respects, without such revisiting standards and doctrines? What does that look like and what are the values, and systemic costs, of any such approach?

Note 6. *Reynolds* cited the next case, *Fisher*, for the rule that offensive contact with something touching the plaintiff's body can be a battery, even without the defendant's touching the body directly. Consider the work the rule does in this context.

Fisher v. Carrousel Motor Hotel, Inc., Texas Supreme Court (1967) (424 S.W. 2d 627)

This is a suit for actual and exemplary damages growing out of an alleged assault and battery. The plaintiff Fisher was a mathematician with the Data Processing Division of the Manned Spacecraft Center, an agency of the National Aeronautics and Space Agency, commonly called NASA, near Houston. The defendants were the Carrousel Motor Hotel, Inc., located in Houston, the Brass Ring Club, which is located in the Carrousel, and Robert W. Flynn, who as an employee of the Carrousel was the manager of the Brass Ring Club. Flynn died before the trial, and the suit proceeded as to the Carrousel and the Brass Ring. Trial was to a jury which found for the plaintiff Fisher. The trial court rendered judgment for the defendants notwithstanding the verdict. The Court of Civil Appeals affirmed. 414 S.W.2d 774. The questions before this Court are whether there was evidence that an actionable battery was committed, and, if so, whether the two corporate defendants must respond in exemplary as well as actual damages for the malicious conduct of Flynn.

The plaintiff Fisher had been invited by Ampex Corporation and Defense Electronics to a one day's meeting regarding telemetry equipment at the Carrousel. The invitation included a luncheon. The guests were asked to reply by telephone whether they could attend the luncheon, and Fisher called in his acceptance. After the morning session, the group of 25 or 30 guests adjourned to the Brass Ring Club for lunch. The luncheon was buffet style, and Fisher stood in line with others and just ahead of a graduate student of Rice University who testified at the trial. As Fisher was about to be served, he was approached by Flynn, who snatched the plate from Fisher's hand and shouted that he, a Negro, could not be *629 served in the club. Fisher testified that he was not actually touched, and did not testify that he suffered fear or apprehension of physical injury; but he did testify that he was highly embarrassed and hurt by Flynn's conduct in the presence of his associates.

The jury found that Flynn 'forceably dispossessed plaintiff of his dinner plate' and 'shouted in a loud and offensive manner' that Fisher could not be served there, thus subjecting Fisher to humiliation and indignity. It was stipulated that Flynn was an employee of the Carrousel Hotel and, as such, managed the Brass Ring Club. The jury also found that Flynn acted maliciously and awarded Fisher \$400 actual damages for his humiliation and indignity and \$500 exemplary damages for Flynn's malicious conduct.

The Court of Civil Appeals held that there was no assault because there was no physical contact and no evidence of fear or apprehension of physical contact. However, it has long been settled that there can be a battery without an assault, and that actual physical contact is not necessary to constitute a battery, so long as there is contact with clothing or an object closely identified with the body. 1 Harper

& James, *The Law of Torts* 216 (1956); Restatement of Torts 2d, §§ 18 and 19. In Prosser, *Law of Torts* 32 (3d Ed. 1964), it is said:

‘The interest in freedom from intentional and unpermitted contacts with the plaintiff’s person is protected by an action for the tort commonly called battery. The protection extends to any part of the body, or to anything which is attached to it and practically identified with it. Thus contact with the plaintiff’s clothing, or with a cane, a paper, or any other object held in his hand will be sufficient; * * * The plaintiff’s interest in the integrity of his person includes all those things which are in contact or connected with it.’

Under the facts of this case, we have no difficulty in holding that the intentional grabbing of plaintiff’s plate constituted a battery. The intentional snatching of an object from one’s hand is as clearly an offensive invasion of his person as would be an actual contact with the body. ‘To constitute an assault and battery, it is not necessary to touch the plaintiff’s body or even his clothing; knocking or snatching anything from plaintiff’s hand or touching anything connected with his person, when, done in an offensive manner, is sufficient.’ *Morgan v. Loyacom*, 190 Miss. 656 (1941).

Such holding is not unique to the jurisprudence of this State. In *S. H. Kress & Co. v. Brashier*, 50 S.W.2d 922 (Tex.Civ.App.1932, no writ), the defendant was held to have committed ‘an assault or trespass upon the person’ by snatching a book from the plaintiff’s hand. The jury findings in that case were that the defendant ‘dispossessed plaintiff of the book’ and caused her to suffer ‘humiliation and indignity.’

The rationale for holding an offensive contact with such an object to be a battery is explained in 1 Restatement of Torts 2d s 18 (Comment p. 31) as follows:

Since the essence of the plaintiff’s grievance consists in the offense to the dignity involved in the unpermitted and intentional invasion of the inviolability of his person and not in any physical harm done to his body, it is not necessary that the plaintiff’s actual body be disturbed. Unpermitted and intentional contacts with anything so connected with the body as to be customarily regarded as part of the other’s person and therefore as partaking of its inviolability is actionable as an offensive contact with his person. There are some things such as clothing or a cane or, indeed, anything directly grasped by the hand which are so intimately connected with one’s body as to be universally regarded as part of the person.’

***630** We hold, therefore, that the forceful dispossession of plaintiff Fisher’s plate in an offensive manner was sufficient to constitute a battery, and the trial court erred in granting judgment notwithstanding the verdict on the issue of actual damages.

In *Harned v. E-Z Finance Co.*, 151 Tex. 641 (1953), this Court refused to adopt the ‘new tort’ of intentional interference with peace of mind which permits recovery for mental suffering in the absence of resulting physical injury or an assault and battery. This cause of action has long been advocated by respectable writers and legal scholars. See, for example, Prosser, *Insult and Outrage*, 44 Cal.L.Rev. 40 (1956); Wade, *Tort Liability for Abusive and Insulting Language*, 4 Vand.L.Rev. 63 (1950); Prosser, *Intentional Infliction of Mental Suffering: A New York*, 37 Mich.L.Rev. 874 (1939); 1 Restatement of Torts 2d s 46(1).

However, it is not necessary to adopt such a cause of action in order to sustain the verdict of the jury in this case. The Harned case recognized the well established rule that mental suffering is compensable in suits for willful torts ‘which are recognized as torts and actionable independently and separately from mental suffering or other injury.’ 254 S.W.2d at 85. Damages for mental suffering are recoverable without the necessity for showing actual physical injury in a case of willful battery because the basis of that action is the unpermitted and intentional invasion of the plaintiff’s person and not the actual harm done to the plaintiff’s body. Restatement of Torts 2d s 18. Personal indignity is the essence of an action for battery; and consequently the defendant is liable not only for contacts which do actual physical harm, but also for those which are offensive and insulting. Prosser, *supra*; *Wilson v. Orr*, 210 Ala. 93 (1923). We hold, therefore, that plaintiff was entitled to actual damages for mental suffering due to the willful battery, even in the absence of any physical injury.

*** [Editor’s note: the discussion of damages and the corporations’ vicarious liability for the actions of Flynn are omitted for the sake of brevity.]

After the jury verdict in this case, counsel for the plaintiff moved that the trial court disregard the answer to issue number eight (no authorization or approval of Flynn’s conduct on the occasion in question) and for judgment upon the verdict. The trial court erred in overruling that motion and in entering judgment for the defendants notwithstanding the verdict; and the Court of Civil Appeals erred in affirming that judgment.

The judgments of the courts below are reversed, and judgment is here rendered for the plaintiff for \$900 with interest from the date of the trial court’s judgment, and for costs of this suit.

Note 1. The rule expressed in *Fisher*, that rudely or angrily removing a plate from someone’s hands is a battery reflects what some courts have referred to as the **doctrine of extended personality**. If something is touching one’s body—such as a purse, backpack, or headphones, or if one’s body is closely connected to or interwoven with something (such as a jockey riding a horse or a person sitting on a stool or swinging on a swing), then interference with the thing or animal can constitute battery so long as the other elements are met. What facts in *Fisher* would you change to make this action fail to be a battery, descriptively? How about normatively, if the answer differs?

Note 2. The court in *Fisher* declined to find IIED, perhaps because it could find a technical battery had happened, and it could justify awarding damages in connection with the mistreatment by an employee. What do you think of the use of battery as a tort here? Is it inappropriate (in potentially twisting the concept of battery to offer redress on these facts)? If it is appropriate is it sufficient (in actually redressing the victim’s harms)? Should an action have been allowed for IIED?

Note 3. The general rule is that tort law does not permit recovery for mere insults or rudeness; to do so would turn the courts into overburdened policers of manner and feelings. But in some cases, the reluctance to allow a claim for IIED may seem more or less satisfying, given the facts. *See Dawson v. Zayre Dep’t Stores*, 346 Pa. Super. 357, 360 (1985) (stating “we believe that this conduct merely constitutes insulting namecalling from which no recovery may be had” and distinguishing *Fisher* and other cases, in which service was denied or customers asked to leave the store from a case in which an employee called a customer an extremely harmful racial epithet when in an argument over a lay-away ticket). Richard Delgado, *Words that Wound: A Tort Action for Racial Insults, Epithets and Name-Calling*, 17 Harv. C.R.-C.L. L. Rev. 133 (1982) argued forcefully in favor of the creation of a special

tort to address hateful or racist speech but his calls have gone unheeded). What benefits would flow from the creation of such a tort? What costs or challenges would it create?

Check Your Understanding (2-4)

Question 1. A student, disliking the grade they received on their Contracts midterm, went to their professor's office hours to complain. When the professor held firm to her original assessment of the exam, the student pulled out a copy of Black's Dictionary and wielded it over the professor's head, snarling as they did so, "Downstairs in my locker, I have a steel-edged ruler that's a lot sharper than this law dictionary! I can't skip my next two classes because participation is graded, but after that, I'm going to come back here and slit your throat! If you're not here, I'm going to make an appointment during your office hours to slit your throat then!" Laughing maniacally, the student then wandered off to Torts class.

If this fails as an assault, it will be because:

An interactive H5P element has been excluded from this version of the text. You can view it online here: <https://saidtorts2d.lawbooks.cali.org/?p=40#h5p-34>

Question 2. With respect to the bolded words in the actual jury instruction below, does the court use an objective or subjective standard?

Question No. 4 on the verdict asks whether Defendant **knew or had been notified** that Defendant's dog had previously injured or caused damage to a person, dog, cat or property. The owner must have notice the dog caused injury to a person, domestic animal or property. Plaintiff must show by the greater weight of the credible evidence that the Defendant had such notice. Notice means actual notice the dog caused injury.

An interactive H5P element has been excluded from this version of the text. You can view it online here: <https://saidtorts2d.lawbooks.cali.org/?p=40#h5p-35>

Chapter 9. False Imprisonment

Elements

- Action with
- Specific intention to confine someone to a defined or bounded place
- That directly or indirectly causes actual and unlawful confinement and
- Harm, or awareness of the confinement

Noguchi v. Nakamura, Intermediate Court of Appeals of Hawai'i (1982) (2 Haw. App. 655)

This is an appeal from an order granting a directed verdict on a claim of false imprisonment. We reverse. The complaint herein asserted two claims for relief: one based on negligence and one on false imprisonment. The court below directed a verdict on the false imprisonment claim and the jury found for the appellee on the negligence claim.

Basically, appellant testified that she and appellee had been girlfriend and boyfriend. She had come to the conclusion that she did not wish to go out with him anymore. On the day in question, he came to see her and asked her to go with him on a date that evening. She refused. After some conversation, he asked her to at least go to the store with him and she consented on the condition, which he agreed to, that he would bring her right back. She then entered his car and they proceeded to the store and returned, stopping in front of her house. She was seated in the car with the car door open when he suddenly drove off. At some point thereafter, she fell, was pushed or jumped from the car, sustaining the injuries complained of. [***]

Appellee contends, however, that since appellant originally entered the car voluntarily, some threat against her to prevent her leaving must have been made or she was at least under an obligation when the car was stopped in front of her parents' home to express a refusal to go further. We do not regard such to be the law. She had refused to go anywhere on the day in question with the appellee but to the store and back. She was back; she was in front of her parents' house, and she had the car door open when appellee suddenly started off. A jury could well have found from her testimony that her consent to go anywhere with the appellee on the day in question was limited to going to the store and back; that she had previously expressly told him she would not go out with him that evening, so that the limited consent had expired; and that her having the door open in the stopped car in front of her parents' home reindicated her lack of consent to any further movement.

The case of *Faniel v. Chesapeake & Potomac Telephone Co.*, 404 A.2d 147 (D.C.App.1979), cited by appellee is not on point. There, the claimant had consented to go to her home in the car. In the course of that journey after a stop was made which she had not anticipated, she changed her mind without expressing the same. But as the court pointed out in that case: Of course, if the defendant goes beyond the implied consent, and does a substantially different act, he will be liable. See *Prosser*, supra, at 104.

Whether the assent given was broad enough to cover the invasion inflicted is a question of fact to be determined by the jury in doubtful cases. 404 A.2d at 153. That is our case.

[***] [T]here was sufficient evidence to go to the jury on the claim of false imprisonment. Because of our disposition of the question of the sufficiency of the evidence, we do not reach the other errors alleged.

Reversed and remanded for a new trial.

Note 1. What does it mean for the lower court to have directed the verdict? What is the status of the negligence count?

Note 2. For what purpose is the court drawing on the implied license doctrine?

Note 3. The court relays the facts with a curious range of possibility regarding what actually happened: “At some point thereafter, she fell, was pushed or jumped from the car.” Why do you think this is so? Do you think it is important (from the parties’ perspectives) which occurred? What bearing might it have on the tort of false imprisonment or on a general understanding of the context for the parties’ actions?

Note 4. False imprisonment is a tort in which there is frequently a power asymmetry of some kind. The tort, after all, seeks to prevent people from limiting others’ freedom of movement. That someone is *capable* of limiting the freedom of another presupposes particular sorts of power, strength, status or opportunity. How do you imagine this power asymmetry might play out in fact patterns that recur in the case law? What patterns would you expect to see regarding who is likely to be bringing false imprisonment actions, against whom and why?

Ali v. Margate, United States District Court, S.D. Florida (2011) (2011 WL 4625372)

Plaintiff Shanaz Ali (“Ali”) filed this action against Defendant Margate School of Beauty, Inc. (“Margate School”), alleging sex discrimination and sexual harassment in violation of Title IX, 20 U.S.C. § 1681 *et seq.*, which prohibits discrimination on the basis of gender in any education program or activity receiving Federal financial assistance. Ali’s Amended Complaint also contains claims for assault, battery, and false imprisonment against Defendant Stanley Barnett (“Barnett”), the owner of Margate School.²⁹ Ali was a student at Margate School, a private trade school, from May of 2010 until late in 2010 or early in 2011. There is no dispute that Title IX applies to Margate School. After the parties engaged in discovery, Defendants moved for summary judgment as to Ali’s claims.³⁰

Ali first registered to attend Margate School’s massage therapy certification class in late May of 2010. She met Defendant Barnett that day after he personally approved her request for discounted tuition. Barnett asked her where she was from, and after she stated she was from Trinidad, he told her he was

²⁹ By separate order, the Court has previously addressed Plaintiff Stephanie Groh’s claim for retaliation in Count II [DE 53].

³⁰ Ali did not allege a claim under Title IX against Defendant Barnett. Therefore the Court does not address the individual liability issue discussed by Defendants in their motion.

British and played cricket. After she began day classes in June of 2010, Barnett approached her in the hallway and said, “You are the girl ... who was in my office before when we started school. So, you did start?”³¹ Barnett asked her if she played cricket, to which Ali replied, “sometimes.” Barnett then stated that “we could play cricket.” Barnett put his hand on Ali’s right hand or forearm for a few seconds when he made this last statement. A week later, Barnett approached her in the hallway, touched her hand or shoulders and moved close to her and asked how she was doing. This contact made Ali uncomfortable. Between late June and early November, there were three to five instances of Barnett approaching her in the hallway and touching her in a similar manner. While Ali stated that she tried to avoid him, she testified that she changed her class schedule from day classes to night classes because of her babysitting situation.

On Monday evening, November 8, 2010, Ali was in the hallway before class when Barnett approached her, asked how she was doing, tapped her shoulder and hugged her. In her errata sheet, Ali adds that Barnett said she was extremely attractive and wanted to help her with her studies. Barnett then said that “Let’s see if we can help each other out.” Ali Deposition at 36–37. Ali did not know what he was referring to as the two went into his office and he closed the door. Barnett sat behind his desk with Ali across from him. *Id.* at 37. Barnett said “Let’s see if we can help each other out, you know, I can probably do something for you. You can do something for me.” Ali felt trapped and stuck and thought if she walked out she would not be able to go to school anymore. *Id.* at 38. Barnett then said that “I’m the owner of the school, you know, I can pay your tuition. I can pay your weekly amount if you, you know, could do something... I can pay your stuff and you can, you know, give me a favor, do me a favor.” Ali assumed he meant a sexual favor, and stated that “you shouldn’t even be saying that. You’re married, you know, you have a kid. I have kids.” Barnett then said, “Well, you know, everybody does it now.” *Id.* at 38–39. Ali declined the proposition, saying “I don’t want to do anything like that.” *Id.* at 39. Barnett said “that he liked Trinidadian women and that he could do anything because he owned the school.” Barnett then asked if Ali had a friend who would do it. Ali deposition at 39. Ali said no and left his office. *Id.* at 40. In her Errata Sheet, she alleges that Barnett followed her into the hallway, touching her and telling her she was attractive, conduct that frightened Ali because she feared that she might be expelled or have her grades adversely affected.

***2** Teacher and co-Plaintiff Stephanie Groh then saw Ali crying and shaking in the hallway. Deposition of Stephanie Groh at 68 [DE 34–4]; Deposition of Shanaz Ali at 42 [DE 33–4]. Upon reaching her, Ali explained that Defendant Barnett had just propositioned her in his office, and she did not know what to do. Ali deposition at 42. Groh told Ali that she would take care of it. Ali did not go to class and went home. She came back to school the next day to speak with Stephanie Groh. Once Ali learned that Groh had been fired, Ali never went back to the school. Ali never told any other student, teacher, or administrator about the incident.

Barnett denies the November 8 incident ever took place. Deposition of Stanley Barnett at 51. Barnett also denied ever making the comment that he was attracted to Trinidadian women. *Id.* at 43. He stated that if an instructor or administrator offered a quid pro quo for sexual favors to a student, such conduct would be investigated as a possible violation of Margate School’s sexual harassment policy.

³¹ Barnett may have stated, “You’re the Trinidadian girl that was enrolling a couple of weeks ago.” Ali deposition at 22.

Margate School’s sexual harassment policy directs students to report any such incidents to the “Director of the School or the Office Manager.” Sexual Harassment Policy [page 13–14 of DE 33–2]. While Miriam Tirado was the Director of the School, it is not clear who the “Office Manager” was at the time of the November 8 incident. The policy then states that if a verbal complaint to the Director has proven ineffective, or you are unable to complain to the Director, then students are to file a complaint through Margate School’s grievance procedure. The procedure starts with a student first notifying her instructor either verbally or in writing, and if not resolved, then the student is to notify the Director of Student Affairs. Handbook at p. 9 [DE 33–2]. Other than telling Groh, there is no evidence that Plaintiff Ali followed the procedures spelled out in the policy. [***]

B. Title IX Discrimination—Quid Pro Quo

Both sides argue that Title VII case law should be used as the basis for analysis of a motion for summary judgment on a Title IX claim. Plaintiff’s claim under Title IX can be maintained under two different theories, both of which Plaintiff asserts in this case. A plaintiff can prove a violation by either showing that the harassment culminated in a “tangible employment action” or that she suffered “severe or pervasive” conduct. [c] As applied to the Title IX area, Plaintiff Ali must show that she was deprived of some benefit or suffered some tangible adverse action, such as decreased grades. [c]

Although Ali testified that she was afraid something adverse to her grades would happen to her after she rejected Barnett’s quid pro quo offer, there is no evidence that any denial of any educational benefit or any adverse educational action ever occurred. Ali’s grades did not suffer as a result of her rejection of Barnett’s alleged advances. Ali suggests that she suffered some sort of constructive discharge because she was afraid to return to school. However, the facts remain that Ali did not return to school on her own choosing. There is no evidentiary basis in the record to support the claim that she suffered a tangible educational action or was denied any benefit on account of her sex. Thus, the Court concludes that there are no disputed issues of material fact concerning the quid pro quo harassment claim. Summary judgment in favor of Margate School on this part of Count I is therefore appropriate.

C. Title IX Discrimination—Hostile Work Environment

[***] Under the hostile work environment theory, “[f]or sexual harassment to be actionable, it must be sufficiently severe or pervasive ‘to alter the conditions of [the victim’s] employment and create an abusive working environment.’” [cc] A plaintiff establishes a prima facie case of hostile work environment by showing: (1) the Plaintiff belongs to a protected group; (2) she was subjected to unwelcome sexual harassment; (3) the harassment complained of was based on sex; (4) the harassment complained of was sufficiently severe or pervasive to alter the conditions of her employment and create an abusive working environment; and (5) the employer is liable. [cc]. [***]

For purposes of the summary judgment motion, it is clear that Plaintiff testified that the conduct was unwelcome, sexual in nature, and related to her gender. Defendant argues that Plaintiff cannot show that the alleged harassment, under an objective standard, was sufficiently severe or pervasive to alter the conditions of Plaintiff’s education and create an abusive environment. Defendant relies upon the *Mendoza* opinion, where repeated vulgar conduct was deemed not sufficiently pervasive but merely rude.

In this action, although Ali meets the subjective component that the harassing conduct was sufficiently severe or pervasive to alter an employee’s terms or conditions of employment, Ali has not met the

objective component. The Court first notes that the various out of district cases cited by Plaintiff involved alleged victims aged 17 and younger. Plaintiff Ali was 24 years old during the relevant period in this action. Although Barnett was substantially older and was the owner of the trade school in question, his slight touching of Plaintiff's hand or arm three to five times in open hallways over a five month period, combined with general questions about how Plaintiff was doing, and culminating in one instance in his office where he allegedly asked for sexual favors in return for free tuition, do not rise the level of sufficiently severe or pervasive conduct under Eleventh Circuit case law. [***]

[T]his Court concludes that even taking all disputed facts in Plaintiff Ali's favor, summary judgment is appropriate in that Plaintiff has failed to show sufficiently severe or pervasive conduct that meets her burden.³²

D. State Law Claims

Defendant Barnett also moves for summary judgment on Plaintiff's state law claims against him. Taking first the claim for false imprisonment, this tort is defined as the unlawful restraint of a person against his will. [c] The gist of false imprisonment is the unlawful detention of the plaintiff and the deprivation of her liberty. "A plaintiff in a false imprisonment action need not show that force was used in the detention or that he or she orally protested to demonstrate the detention was against his or her will.... However, a plaintiff alleging false arrest must show the restraint was unreasonable and unwarranted under the circumstances." A plaintiff is not restrained when there is a reasonable means of escape, which is apparent or known to the person. [c]

In this action, Plaintiff Ali has failed to show that any restraint was used in that she agreed to go with Barnett into his office and she could have left his office at any time. In fact, Ali did leave Barnett's office prior to the conversation being over, as Barnett allegedly followed her into the hallway to ask her to reconsider his offer. Although the door to the office was closed while Plaintiff was inside the office with Barnett, and Plaintiff was subjectively afraid of the consequences of her leaving, a reasonable means of escape was apparent. The Court therefore concludes that Plaintiff has failed to prove as a matter of law that the tort of false imprisonment was committed.

Turning next to the assault claim, under Florida law, an assault is any intentional, unlawful threat by word or act to do violence to another, coupled with an apparent ability to do so, and doing some act which creates a well-founded fear that such violence is imminent. [cc] Based upon the record as a whole, there is no evidence that any violence was ever imminent or threatened by Barnett during the instances that he touched Ali, nor during the alleged proposition in his office. There is no construction of the facts in the record by which one could conclude that Ali had a well-founded fear that any violence was imminent. Therefore, summary judgment in favor of Barnett on the assault claim is appropriate.

*6 Finally, turning to the battery claim, under Florida law, a battery occurs when a person "actually and intentionally touches or strikes another person against the will of the other." [cc] In this case, Ali testified that Barnett touched her several times against her will, causing her to be uncomfortable. While Defendant argues that Barnett lacked the intent to cause harm or that Ali never told Barnett that the touching was unwelcome, the Court must conclude at the summary judgment stage that Plaintiff has

³² Based upon this conclusion, the Court does not address the employer liability prong regarding the adequacy of the sexual harassment policy and whether Ali unreasonably failed to take advantage of the policy.

set forth disputed issues of material fact that preclude the granting of summary judgment on her battery claim.

Accordingly, it is ORDERED AND ADJUDGED as follows:

1. Defendants' Motion for Summary Final Judgment [DE 33] is hereby GRANTED in part as to Counts I [Title IX Violation: Harassment/Discrimination against Ali], IV [False Imprisonment Claim] and the assault claim in Count III, and DENIED as to the battery claim in Count III;
2. Defendants' Motion for Summary Final Judgment [DE 32] is hereby DENIED as a duplicative motion.

Note 1. *Ali v. Margate* builds on torts you've seen—assault, battery and false imprisonment—to add a federal claim for discrimination in the workplace. While employees cannot sue employers for negligent injuries sustained on the job—since workers' compensation exists to address those—they may sue for intentional torts as you have learned in *Villa v. Derouen*. In addition, employees can report employers using various institutional and industry-specific mechanisms. Finally, they can bring lawsuits of various kinds, but these are usually the least good option. Employment discrimination and toxic workplace cases are notoriously difficult to win and often not worth the professional stress and reputational costs, to say nothing of the legal fees that may be involved with lengthy litigation. Why do you think the bar for recovery is so high? How might you frame your answer in terms of tort law's purposes?

Note 2. In light of the momentum created by the “#metoo” movement, cases such as these could become less frequent if employers respond meaningfully, perhaps by bolstering their training, supervision and reporting protocols or by taking other steps to improve their workplace environment. Cultural factors play a role in this context, as well; if victims fear retaliation or routinely face doubt when raising allegations of harassment or misconduct, reporting will continue to present an option worse than the alternative of putting up with the wrongful conduct or leaving the working environment, where that's possible. Normatively, to what extent do you think such conduct ought to fall to the tort system to regulate? Also, when should bad behavior be deemed so bad that it's beyond an acceptable range and becomes something “extreme and outrageous” (along the lines of the tort of outrage or intentional infliction of emotional distress)? Should the prevalence of discriminatory behavior make it harder to recover because of the widespread nature of the bad behavior? Does societally prevalent conduct require more generalized legal measures like legislative or executive action, that is, legal measures besides tort litigation which is particularized to individuals or even classes of individuals?

Note 3. In some instances, civil rights violations do not or should not amount to torts violations. Martha Chamallas, *Discrimination and Outrage: The Migration from Civil Rights to Tort Law*, 48 Wm. & Mary L. Rev. 2115 (2007) (exploring the interplay between the domains of civil rights laws and torts, critiquing the “gap-filler” approach and advocating for a reconceptualization of the tort of outrage), <https://scholarship.law.wm.edu/wmlr/vol48/iss6/2/>

What risks and opportunities can you imagine arising from the way the two areas of law either overlap or remain distinct from each other?

Note 4. From the disposition of this case, what would you assume the plaintiff sought? From her complaint, here was the request:

[T]he Plaintiff Ali demands judgment against the Defendants Margate and Barnett, for damages in excess of \$15,000.00, costs, interest, and such other and further relief that is available under the law and also seeks exemplary and punitive damages against the Defendants for the intentional wanton and willful acts of Defendant Barnett.

Ali alleges that Barnett's conduct caused her to drop out of beauty school that she had paid tuition to attend. In light of that allegation, does the nature and amount of the remedy sought seem appropriate? What do you observe about the remedies tort law most commonly awards?

Note 5. Do the plaintiff's gender and nationality or race seem relevant to the substantive claims, in your view? Whichever way you answered, do you think they might be relevant to the legal disposition of the case? What do you observe about the institutional context (a beauty school) and the fact that one of the school's teachers, Stephanie Groh, joined the suit?

**Talcott v. National Exhibition Co., Supreme Court, Appellate Division, 2d,
NY (1911)
(144 A.D. 337)**

The defendant appeals from a judgment of a Trial Term of the Supreme Court in Westchester county, entered upon a verdict of a jury in an action for false imprisonment, and from an order denying a motion for a new trial. The facts are as follows:

On the morning of the 8th of October, 1908, the plaintiff went into the inclosure of the defendant in the city of New York to buy some reserved seats for a baseball game which was to be held there in the afternoon of that day. These seats were sold at a number of booths within the inclosure. The *338 plaintiff was unsuccessful in his quest, as all the reserved seats had been sold. He tried to leave the inclosure through some gates used generally for ingress and exit. A considerable number of other persons were trying to leave the inclosure through the same gates at the same time. It appears that the baseball game which was to take place was one of very great importance to those interested in such games, and a vast outpouring of people were attracted to it. Many thousands of these came early in the day to seek admittance to the ball grounds, and the result was that the various gates used generally for entrance or exit were thronged with a dense mass of people coming in.

The plaintiff was prevented by the servants of the defendant from attempting to pass out through this throng, and as a result of this interference he was detained in the inclosure for an hour or more, much to his annoyance and personal inconvenience. The plaintiff and those similarly situated made many attempts to get out through these gates, and in the restraint put upon them to defeat their efforts they were subjected to some hauling and pushing by the defendant's special policemen. Finally the plaintiff and the others were taken through a club house within the inclosure and allowed to go out through the entrance to the club house to the street.

Concededly the plaintiff had a legal right to leave the inclosure, and the defendant had no legal right to detain him therein against his will. But the right of each had corresponding duties. A temporary interference with the plaintiff's legal right of egress could be justified as a proper police measure, if the plaintiff sought to exercise such right under circumstances likely to create disorder and danger.

Assuming, however, that the defendant was justified in preventing the plaintiff from passing out through the gates in question, it should have directed him to pass out through some other means of exit, if there were any. The plaintiff told the agents of the defendant of his desire to get out, but received no directions or suggestions how to get out. The defendant claims that the plaintiff might have gone out through other gates in another portion of the field used for the entrance of motor cars and other vehicles; but the plaintiff swears that he did not know of the other gates, and there is no proof that his attention was called to *339 them in any way when he and the others sought to go out. He got out in the end, not through the gates for vehicles, but through the club house, on the permission and direction of the defendant. Granting that the restraint placed upon the plaintiff in preventing his going out through the gateways through which he sought exit was justifiable as a police measure, yet the defendant owed him an active duty to point out the other existing methods of egress. It could not stand idly by, and simply detain and imprison the plaintiff against his will.

We see no reason to interfere with the verdict of the jury in its finding that the plaintiff's detention was unjustifiable under the circumstances. The damages awarded were in the sum of \$500. The plaintiff proved no special damage, nor was he obliged to. All damages awarded in cases of false imprisonment partake to some extent of "smart moneys," and the sum awarded here is not so excessive as to justify interference on our part.

The judgment and order are affirmed, with costs.

Note 1. Courts take different approaches to identifying what constitutes "unlawful confinement." There is broad consensus that when a reasonable means of exit exists and a person does not take it, there is no confinement. Some courts suggest that a finding of confinement requires that the plaintiff has made reasonable attempts at escape, but even those that apply an inquiry into whether the plaintiff could have escaped do not deem it necessary where the escape attempt would be dangerous. Coercion to remain only sometimes creates the necessary grounds for finding confinement. Threatening to fire an employee wrongly suspected of shoplifting may cause him to remain on site until the error is cleared up. However, his choice to remain defeats any false imprisonment claim, even if he feared losing his job and would face severe economic consequences for leaving it. However, retaining something of value to a person can count as confinement for false imprisonment, whether that is the person's wallet, keys or children.

Note 2. What do you think the real-world consequences of a ruling like this one will be? Do you think that might have mattered to the court in its interpretation of the facts?

Note 3. Which of tort's purposes do you think this ruling most serves or disserves, and why? Answering this question may help you identify the ruling's doctrinal underpinnings and anticipate its likely impact.

Chapter 10. Intentional Infliction of Emotional Distress (“IIED”)

Elements

- Intent: *either* reckless or intentional, plus
- Conduct that is extreme **and** outrageous and
- Causes severe emotional distress

As noted in the introduction to Module 2, IIED was an outlier among the intentional torts rather than a creature of the writ system. Its elements reflect some of the uncertainty and compromises that led to its eventual adoption. First, its intent standard is lower than the usual intent standard in that it permits either intent *or* recklessness (which is a higher culpability standard than negligence but lower than intentional action). The second prong requires *both* extreme *and* outrageous behavior. Sometimes conduct is outrageous but happens only once and may fail to qualify as extreme. More commonly small irritating actions can, when done over many months or years, rise to a level that causes the conduct to qualify as extreme and outrageous. The conduct, however, is indeterminate—that is, not specified in advance. This indeterminacy is why the tort’s harm standard is heightened. Recall that in battery and trespass, no harm even need be proven; by contrast with IIED the harm must demonstrably exist *and be severe*. Its amorphous shape and its emphasis on emotional evidence has led courts to disfavor it or to refuse to adopt it in many instances. In some jurisdictions, the tort is only allowed where the facts provide an alternate theory of recovery; in others the tort is a “gap-filler” and available only where no other means of redress exists. The severe emotional distress is measured subjectively, not objectively. In theory, all prongs of the doctrine are questions of fact for the jury. In practice, the “outrageousness” element is frequently decided by a judge.

Questions or Areas of Focus for the Readings

- What’s different about IIED’s intent standard? What might that reflect?
- What are the risks and benefits of having a flexible, fact-specific standard for “extreme and outrageous” conduct?
- What else differentiates IIED from the core intentional torts you have learned?

Mitchell v. Giambruno, Supreme Court, Appellate Division, Third Department, New York (2006) (35 A.D.3d 1040)

Plaintiffs are a same-sex couple who purchased and moved into a house in the Village of Dannemora, Clinton County, in 1999. In this action commenced in November 2002, plaintiffs accused defendants,

their neighbors, of, among other things, the intentional infliction of emotional distress. As the result of a jury verdict, plaintiff Susan Mitchell was awarded the sum of \$50,000 and plaintiff Elizabeth Meseck was awarded \$35,000. Defendants Michael Giambruno, Corrine Giambruno and Kimberly Granmoe (hereinafter collectively referred to as defendants) [fn] appeal, contending that plaintiffs' trial evidence was insufficient to support the alleged cause of action.

It is well settled that in a cause of action for intentional infliction of emotional distress, a plaintiff must plead and prove four elements: (1) extreme and outrageous conduct; (2) the intentional or reckless nature of such conduct; (3) a causal relationship between the conduct and the resulting injury; and (4) severe emotional distress [cc]. Plaintiffs' trial evidence reveals that the interaction between plaintiffs and defendants began as a result of what may fairly be characterized as a boundary line dispute. This dispute escalated and a criminal trespass complaint was filed by the Giambrunos against Mitchell and a restraining order was issued against her. Thereafter, for approximately two years, defendants conducted what can only be characterized as a relentless campaign of lewd comments and intimidation directed at plaintiffs and their lifestyle, both in private and in public. The final act prior to the institution of this action occurred when defendants constructed two mock grave sites on the Granmoes' property directly facing plaintiffs' home, which created a fear in plaintiffs that the graves were intended for them.

***1042** Although insulting language intended to denigrate a person may not, in and of itself, rise to the required level of extreme and outrageous conduct, liability may be premised on such expressions where, as here, defendants' campaign of harassment and intimidation is constant. [cc] Accordingly, we conclude that this record contains sufficient evidence to support the jury's determination that the first two elements of the cause of action have been proven, i.e., that the conduct of the defendants was extreme, outrageous and intentional.

Defendants' arguments that plaintiffs failed to prove a causal connection between defendants' conduct and plaintiffs' illnesses is based on plaintiffs' failure to ask either medical witness for an opinion concerning causation and because defendants allege that plaintiffs had other stressors in their lives. We are unpersuaded by either argument. Insofar as a participant (as compared to a bystander) is concerned, where a duty owed the participant is breached, resultant injury is compensable only if it is a direct (not consequential) result of the breach [cc]. Here, the evidence of direct injury from the breach is manifest. Nurse practitioner Paula Covey testified on behalf of Mitchell, and physician Richard Webber testified on behalf of Meseck. Both testified concerning their training and experience in diagnosing and treating anxiety and depression and the resultant physical manifestations, if any. Both testified that plaintiffs were patients in their office prior to and during the two years encompassed by defendants' conduct. Each testified that their patients' level of anxiety increased as did the depth of their depression as they continued to complain about defendants' conduct, the necessity of retaining counsel, the lawsuit and the trial. The frequency with which plaintiffs sought treatment, as well as their medication to control their conditions, increased during this period. Covey testified to Mitchell's resultant indigestion, diarrhea and irritable bowel syndrome and her hospitalization for brief periods on more than one occasion.

Given this testimony, we conclude that the causal connection between defendants' conduct and plaintiffs' illnesses was well within the ken of the ordinary lay juror and the medical practitioner's opinion as to causation would be mere surplusage. Moreover, given the timing of the events, the jury could rationally conclude that the ***1043** other stressors—Mitchell's job stress, Meseck's stress in

caring for Mitchell’s 101-year-old grandmother and the arguments they had with each other over whether to retain counsel and sue—all were temporarily related to defendants’ conduct and were caused or exacerbated by them. Finally, the jury could rationally conclude from the evidence that the emotional distress of each plaintiff was severe.

To the extent not hereinabove discussed, we have considered defendants’ remaining arguments and found each to be lacking in merit.

ORDERED that the judgment is affirmed, without costs.

Note 1. Given that insulting language alone is almost never enough to qualify as “extreme and outrageous,” what additional facts or factors seem to have driven the court’s ruling?

Note 2. As you continue to learn about IIED, you will see that it serves particular purposes that reflect societal values at different moments in time. Consider whether its elements and application create an optimal balance. Should sociological factors and differences of identity be taken into account when evaluating whether particular behavior is “extreme” and/or “outrageous”? What is the risk of incorporating particular perspectives and what are the costs of not doing so?

Note 3. IIED claims often fail when plaintiffs do not show a significant change to their sense of wellbeing. Fairly or unfairly, courts struggle to find that change when plaintiffs are dispositionally nervous or depressive; if they are generally happy people who undergo significant change *because of the extreme and outrageous conduct of the defendant*, the IIED claim stands a higher chance of success. In one sense, this simply reflects the requirement that the distress be “severe.” In another sense, however, it may stack the deck in favor of particular kinds of personalities and temperaments, biasing the law against others. Should tort law treat all plaintiffs equally no matter their backgrounds or dispositions? Is the eggshell plaintiff doctrine reconcilable with this default of permitting recovery only in cases where a plaintiff didn’t start out with signs of any distress?

Note 4. At common law, there was a firm rule against recovering for purely emotional distress under *Lynch v. Knight*, 9 H.L.C. 577, 598 (1861) (“mental pain or anxiety the law cannot value, and does not pretend to redress.”) However, in the late 1930s, two torts jurists charted judicial departures from that norm and were able to categorize them in service of an argument that courts *had* been allowing recovery for emotional distress. Calvert Magruder, a judge on the Court of Appeals for the First Circuit and William Prosser, the torts scholar and academic, were both drafters of the Restatement and would eventually be responsible for introducing the tort of IIED. Among the documented exceptions to the *Lynch* rule were insults or abuse by common carriers (as you saw in *Luther and Henderson*); harassment by creditors wielding power over debtors; cruel or vicious practical jokes; stalking or significant sexual harassment; and claims for mishandling bodily remains or interference with death and death rituals.

Today, the fact patterns that tend to fall into “extreme and outrageous” conduct include some aspects of those three clusters. For instance, if defendant’s conduct is continuous or ongoing, liability is likelier. If a plaintiff has no practical way out (because they are in the care or custody of an entity) or lacks the power to make a change (because of a power dynamic or economic coercion), again the conduct tends to be judged more harshly against the defendant. Similarly, if there is a potential abuse of authority, a finding of outrage is likelier. As you evaluate IIED fact patterns, look at the relationships involved: were the parties in a hierarchical relationship, such as landlord/tenant, supervisor/employee,

professor/student or creditor/debtor? Was there a conflict of professional interest? It may go without saying but where there is evidence that the defendant knowingly exploited the plaintiff's vulnerable condition or particular sensitivity, the plaintiff's case strengthens. Along those lines, where the defendant is shown to have lied or to have a secret intent to inflict harm, the conduct is likelier to be found outrageous.

Banks v. Fritsch, Court of Appeals of Kentucky (2001) (39 S.W.3d 474)

The appellant, Wade Banks, brought this complaint against the appellee, John Fritsch, alleging false imprisonment, assault and battery, and outrageous *476 conduct. A jury trial was conducted on July 21, 1999. At the close of Banks's case, the trial court directed a verdict in favor of Fritsch, finding that Banks had failed to present evidence that he had been damaged by Fritsch's conduct. We find that the trial court erred in dismissing the claims for false imprisonment and assault and battery as there was sufficient evidence of emotional damages to warrant submitting the issue to the jury. However, we also conclude that the tort of outrageous conduct is not available under the facts presented in this case. Hence, we reverse the trial court in part, affirm in part, and remand this action for a new trial.

Since the trial court dismissed this action on a motion for a directed verdict, we shall view the evidence in the light most favorable to the appellant. In June 1996, Banks was 17 years old and was a Junior at Bourbon County High School. His last class of the school day was Agriculture Wood Construction, taught by Fritsch. By his own admission, Banks had either skipped the class or left the class early on a number of occasions during that semester.³³ Banks testified that, while he was walking to the class on June 4, another student told him that Fritsch had a chain, and was planning to chain Banks up to keep him from skipping class. Nevertheless, Banks proceeded to the class.

Banks testified that when Fritsch walked into the classroom, he had a large log chain over his shoulder and had several key locks on his belt loop. Fritsch then told Banks that he was going to keep him from leaving the class early. After taking roll, Fritsch directed Banks to put his leg up on a chair so he could put the chain around Banks's ankle. Banks states that he initially protested, and then went along after Fritsch repeated the instruction. Fritsch secured the chain around Banks's ankle, and led him outside to an area where the class was painting feed troughs. Fritsch then put the chain around a tree, locked it, and told Banks not to go anywhere.

The entire class followed Fritsch and Banks from the classroom to the tree. After Banks was secured to the tree, Fritsch returned to the classroom and the other students went on with their projects. Banks sat down under the tree, removed his shoe and began trying to work the chain loose. After several minutes, Banks was able to remove the chain from his ankle, and he then attempted to leave the school premises. Several of his classmates chased Banks down, tackled him, and then carried Banks back to

³³ Fritsch's records show that Banks had missed class seven or eight times from January through April, and an additional ten days during May. However, the school's attendance records only show Banks absent from the class on three days. In his testimony, Banks admitted that he had skipped the class at least eight times. Fritsch's records also show that several other students skipped the class more often than Banks. According to Banks, the other students were in his work group, and he was often left to complete projects alone. Fritsch testified that he was aware of this problem, and gave Banks the painting assignments so that Banks might be able to complete his class work.

the tree. Fritsch returned, placed another chain around Banks's neck, and then secured it to the chain around the tree.

Banks testified that he initially stood up and held the chain to keep its weight off of his neck. After about fifteen minutes, he got tired of holding the chain, so he sat down and began crying. Banks told another student that the chain was bothering him, and the student went to tell Fritsch. Several minutes later, Fritsch came and removed the chain from Banks's neck. However, Fritsch then secured the other chain tightly around Banks's ankle.

Thereafter, Fritsch and Banks began discussing his grades in the class and what it would take from him to pass. Fritsch returned to the classroom to check his records to see if Banks was in a position to pass the class. Upon returning five minutes later, Fritsch told Banks that he could pass the class if he painted the three remaining *477 feeder and mineral troughs. Banks agreed and Fritsch removed the chain. Banks subsequently finished the painting assignments, and he received a passing grade in Fritsch's class. Banks testified that the chaining incident took place over a period of about an hour and a half.

Fritsch's account of the incident differs only slightly in the details, but markedly in tone. Fritsch testified that the idea of chaining Banks started as a joke between him and the other students in the class. Several days prior to the incident, Fritsch made an off-hand comment in front of the class to the effect that perhaps he should chain the truant boys to keep them from skipping class. On June 4, as Banks was arriving for class, the other students reminded Fritsch of this statement. After some prodding from the class, Fritsch decided to go forward with the plan.

Fritsch further testified that Banks never objected to the chaining, and in fact, he went along with the joke and appeared to enjoy the attention. Fritsch did not recall placing the chain on Banks's leg in the classroom and leading him outside. This testimony was contradicted somewhat by another teacher, Ralph Speakes, who saw Banks leaving Fritsch's classroom with the chain around his ankle. However, Speakes also testified that everyone (including Banks) seemed to be laughing about it. In addition, Fritsch states that after Banks managed to remove the chain the first time, he called it to the attention of the other students and dared them to catch him. Several students informed Fritsch about Banks's escape, and they asked Fritsch what they should do about it. Fritsch told them that Banks should come back and finish the project, but he stated that he did not tell any of the students to bring Banks back. Speakes testified that Banks appeared to be leading the chase, and after the students caught up with Banks, they merely led him back to the class area. Fritsch denied that Banks ever showed that he was upset about the chaining or that he ever asked for the joke to stop, except for when Banks complained about the chain around his neck. Fritsch steadfastly denies that the chaining was intended as a punishment, or that he ever intended to hurt or humiliate Banks. Rather, Fritsch merely intended it as a light-hearted prank to impress on Banks the importance of staying in class and finishing his assignments. Fritsch further stated that the entire incident took place over 25 to 30 minutes.³⁴

Banks testified that he was deeply upset by the chaining and thought about it often. After the incident was publicized, he states that other students gave him a hard time about it on several occasions. He also received a lot of unwelcome and negative media attention over the incident. In response, he

³⁴ Following a complaint by Banks's mother, the school superintendent investigated the incident and suspended Fritsch for 45 days. Fritsch challenged the suspension and sought a hearing. The Kentucky Department of Education appointed a three-member tribunal to hear the matter pursuant to KRS 161.790. The Tribunal conducted a hearing and set aside the suspension.

decided that he could not return to Bourbon County High School in the fall. Instead, he went to live with his father and attended his senior year of high school in Columbia, Missouri. Banks testified that the move was traumatic for him, and it was difficult for him to fit in at his new school.

Banks saw a psychologist to discuss his feelings once prior to the move to Missouri. Banks further testified that sometimes he has flashbacks and sometimes starts to cry over memories of the chaining. His family members stated that Banks had a hard time dealing with the incident and often seemed withdrawn. However, there was no expert testimony describing Banks's emotional state following the chaining.

At the close of Banks's case, the trial court granted Fritsch's motion for a directed verdict. The court determined that *478 there was enough evidence to establish that a false imprisonment and an assault and battery occurred. However, the court concluded that there was no evidence that Banks had been damaged by Fritsch's conduct. The trial court stated on the record:

I mean, this strikes me as being exactly what it's characterized as, a prank, and perhaps one that was not appreciated by Mr. Banks and I can understand that, but I don't see that there's been any harm done here. Clearly, Mr. Fritsch should not have done this. He's been told that by a number of people, I think he realizes that. The fact is it happened, and basically there seems to be no harm, no foul here. And I haven't been proved-it hasn't been proven to me, and therefore I don't think the jury can find that there are damages here that Mr. Banks has suffered. There's evidence of that, I don't think that that is significant at this point. I think on the basis of the damages issue, that I am going to direct a verdict here in favor of Mr. Fritsch on all of these counts. I just don't think the jury has enough evidence to decide that Mr. Banks has been damaged by the incidence [*sic*], that it has been proven to then happen.

The trial court's written order granted the directed verdict for Fritsch based upon the oral findings in the record. Banks now appeals, arguing that there was sufficient evidence of damages to warrant submitting the issue to the jury. He further argues that he was also entitled to an instruction on punitive damages.

Fritsch responds that the trial court properly granted his motion for a directed verdict because Banks failed to establish the elements of false imprisonment, assault and battery, and outrageous conduct. However, the trial court specifically granted the directed verdict based upon lack of evidence to establish that Banks was damaged by Fritsch's actions. Moreover, the trial court found that Banks had presented sufficient evidence to create a jury issue on his claims alleging false imprisonment and assault and battery. Since Fritsch did not file a cross-appeal contesting this finding, this appeal is limited to the question of whether Banks presented sufficient evidence of damages to overcome Fritsch's motion for a directed verdict.

On a motion for directed verdict, the trial judge must draw all fair and reasonable inferences from the evidence in favor of the party opposing the motion. When engaging in appellate review of a ruling on a motion for directed verdict, the reviewing court must ascribe to the evidence all reasonable inferences and deductions which support the claim of the prevailing party.³⁵ Once the issue is squarely presented to the trial judge, who heard and considered the evidence, a reviewing court cannot substitute its

³⁵ Meyers v. Chapman Printing Co., Inc., Ky., 840 S.W.2d 814, 821 (1992).

judgment for that of the trial judge unless the trial judge is clearly erroneous.³⁶ However, a trial judge cannot enter a directed verdict unless there is a complete absence of proof on a material issue or if no disputed issues of fact exist upon which reasonable minds could differ. Where there is conflicting evidence, it is the responsibility of the jury to determine and resolve such conflicts, as well as matters affecting the credibility of witnesses.³⁷

In order to consider the propriety of the trial court's decision to grant the motion for a directed verdict, we must first consider the nature of the claims asserted by Banks. The action for the tort of false imprisonment, sometimes called false arrest, is a lineal descendant of the old action of trespass to person. It protects the personal interest in freedom from physical *479 restraint.³⁸ The interest involved is "in a sense a mental one," and false imprisonment may be maintained without proof of actual damages.³⁹ The tort is complete after "even a brief restraint on the plaintiff's freedom," and the plaintiff may recover nominal damages.⁴⁰ The plaintiff is entitled to compensation for loss of time, for physical discomfort or inconvenience, and for any resulting physical illness or injury to health. Since the injury is in large part a mental one, the plaintiff is also entitled to damages for mental suffering, humiliation and the like.⁴¹

Kentucky cases define false imprisonment as being any deprivation of the liberty of one person by another or detention for however short a time without such person's consent and against his will, whether done by actual violence, threats or otherwise.⁴² Furthermore, false imprisonment requires that the restraint be wrongful, improper, or without a claim of reasonable justification, authority or privilege.⁴³ Fritsch's potential liability does not arise out of his efforts to keep Banks from leaving the class, and there is no contention that Fritsch was acting within the scope of his authority as a teacher. Rather, Fritsch's primary defense is that there was no imprisonment because Banks consented to being chained.

There are no Kentucky cases which directly discuss what evidence is necessary to prove damages from false imprisonment. However, a number of cases are instructive insofar as they address evidentiary issues relating to submission of the issue of damages to the jury. In *Butcher v. Adams*,⁴⁴ the plaintiff's testimony that he was humiliated by his false arrest on charges relating to the operation of his tavern was mitigated by evidence that he had previously been arrested on similar charges. The court noted that this evidence was sufficient for the jury to consider whether the plaintiff had actually been embarrassed by the false imprisonment.

³⁶ *Bierman v. Klapheke*, Ky., 967 S.W.2d 16, 18–19 (1998).

³⁷ *Id.* at 19.

³⁸ *Prosser & Keeton on Torts* § 11, at 47 (5th ed.1984) (hereafter *Prosser & Keeton*).

³⁹ *Id.* at 47.

⁴⁰ *Id.* at 48.

⁴¹ *Id.*

⁴² *Grayson Variety Store, Inc. v. Shaffer*, Ky., 402 S.W.2d 424 (1966); *Great Atlantic & Pacific Tea Co. v. Billups*, 253 Ky. 126, 69 S.W.2d 5 (1934); *Ford Motor Credit Co. v. Gibson*, Ky. App., 566 S.W.2d 154 (1977). See also *Columbia Sussex Corp., Inc. v. Hay*, Ky.App. 627 S.W.2d 270 (1981).

⁴³ See *Great Atlantic & Pacific Tea Co. v. Smith*, 281 Ky. 583, 136 S.W.2d 759 (1939); *J.J. Newberry Co. v. Judd*, 259 Ky. 309, 82 S.W.2d 359 (1935); and *Louisville & Nashville Railroad Co. v. Mason*, 199 Ky. 337, 251 S.W. 184 (1923).

⁴⁴ 310 Ky. 205, 220 S.W.2d 398 (1949).

In *Bradshaw v. Steiden Stores, Inc.*,⁴⁵ a store patron was detained for an hour while the store owner checked on the validity of her check. The store owner then told her to go to a back room, where briefly the patron was questioned by two policemen. Once the validity of the check was established, the patron was allowed to go. The former Court of Appeals acknowledged that the patron had established a “borderline” case of false imprisonment. However, the Court noted that there was no evidence that the patron had been unnecessarily humiliated or embarrassed by the incident. Since at most the evidence would have justified an award of nominal damages, the Court concluded that the directed verdict in favor of the store owner was not reversible error. Similarly, in *SuperX Drugs of Kentucky, Inc. v. Rice*,⁴⁶ this Court held that, in an action for false imprisonment where the person is subsequently and properly charged with the commission of a felony, she can recover damages only for that mental suffering and embarrassment *480 which she endured during the period prior to her arrest. Under these circumstances, this Court concluded that the plaintiff was entitled to no more than nominal damages, and the jury’s award of \$75,000.00 in compensatory damages was clearly excessive.

The common thread among all these cases is that a plaintiff may be entitled to at least nominal damages arising from the humiliation, emotional distress or damage to reputation caused by the false imprisonment. “Humiliation and embarrassment are, by their nature, not easily quantified...”⁴⁷ Nevertheless, the degree of humiliation or embarrassment actually suffered by the plaintiff is a factual matter for the jury to decide.

There was clearly a factual issue concerning whether Fritsch’s conduct constituted an unlawful imprisonment of Banks. Furthermore, Banks testified that he suffered humiliation, embarrassment, emotional distress and he was held up to the ridicule of his peers by being publicly chained. There was contrary evidence that Banks did not express any distress during the chaining. Nevertheless, we are satisfied from the record that the jury could have returned a verdict for Banks for an amount greater than nominal damages. Consequently, we find that the trial court’s decision to dismiss this claim was erroneous.

Banks’s second claim is that Fritsch’s conduct amounted to an assault and battery. Assault is a tort which merely requires the threat of unwanted touching of the victim, while battery requires an actual unwanted touching.⁴⁸ Since intent is an essential element of assault and battery, the trial court properly left to the jury the issue of Banks’s consent to the chaining.⁴⁹ However, a plaintiff need not prove actual damages in a claim for battery because a showing of actual damages is not an element of assault or battery and, when no actual damages are shown for a battery, nominal damages may be awarded.⁵⁰ Furthermore, a recovery for emotional distress caused by the assault or battery is allowable as an element of damages in an action based upon those torts.⁵¹ Consequently, we find that the trial court’s dismissal of Banks’s claims for assault and battery also was erroneous.

⁴⁵ Ky., 265 S.W.2d 64 (1954).

⁴⁶ Ky. App., 554 S.W.2d 903 (1977).

⁴⁷ *Daugherty v. Kuhn’s Big K Store*, Ky. App., 663 S.W.2d 748, 752 (1983) (quoting *Kentucky Commission on Human Rights v. Fraser*, Ky., 625 S.W.2d 852, 855 (1981)).

⁴⁸ *Brewer v. Hillard*, Ky. App., 15 S.W.3d 1, 8 (1999).

⁴⁹ *Graves v. Dairyland Insurance Group*, Ky., 538 S.W.2d 42, 45 (1976).

⁵⁰ *Vitale v. Henchey*, Ky. 24 S.W.3d 651, 659 (2000) (citing 6 Am. Jur. 2d., Assault and Battery §§ 144 and 146).

⁵¹ *Rigazio v. Archdiocese of Louisville*, Ky. App., 853 S.W.2d 295, 299 (1993).

Banks's third claim was that Fritsch's conduct amounted to the tort of outrageous conduct. The trial court did not address this claim, but presumably the court's finding that Banks failed to prove damages applies to this claim also. The tort of intentional infliction of emotional distress, or outrage, was first recognized in Kentucky in *Craft v. Rice*.⁵² In that case, the Kentucky Supreme Court adopted the following portion of Section 46 of the Restatement (Second) of Torts:

One who by extreme and outrageous conduct intentionally or recklessly causes severe emotional distress to another is subject to liability for such emotional distress, and if bodily harm to the other results from it, for such bodily harm.⁵³

In order to recover, the plaintiff must show that defendant's conduct was intentional or reckless, that the conduct was so outrageous and intolerable as to offend generally accepted standards of morality and decency, that a causal connection *481 exists between the conduct complained of and the distress suffered, and that the resulting emotional stress was severe.⁵⁴ An action for outrage will not lie for "petty insults, unkind words and minor indignities"; the action only lies for conduct which is truly "outrageous and intolerable."⁵⁵

In addition, the tort of outrage is intended as a "gap-filler," providing redress for extreme emotional distress where traditional common law actions do not. Where an actor's conduct amounts to the commission of one of the traditional torts such as assault, battery, or negligence for which recovery for emotional distress is allowed, and the conduct was not intended only to cause extreme emotional distress in the victim, the tort of outrage will not lie. Recovery for emotional distress in those instances must be had under the appropriate traditional common law action.⁵⁶

We have previously held that Banks may be able to recover emotional damages arising from false imprisonment, assault or battery. Hence, Banks must show that Fritsch's actions were intended only to cause him extreme emotional distress, rather than to merely touch or to deprive him of his liberty. We find no evidence in the record which would support such a finding by the jury. As a result, Banks's claim of outrageous conduct would not be appropriate in this case, and the trial court properly granted a directed verdict on this cause of action.

Lastly, Banks argues that he was entitled to an instruction on punitive damages. The trial court did not address this issue because it dismissed the action based upon lack of evidence of compensatory damages. Since we are remanding this action for a new trial, the trial court must consider the propriety of an instruction on punitive damages based upon the evidence presented at that time.

Note 1. What does it mean when the court calls IIED a "gap-filler"? What do you understand about its purpose and scope so far? Why do you suppose it arose, rather than having changes arise within the other torts such as battery, assault, and false imprisonment?

Note 2. Revisit the facts of *Ruiz v. Bertolotti*. What interest was the court protecting? What conduct was the court seeking to limit or prevent? Is IIED better understood as a "gap-filler" or a backstop?

⁵² Ky., 671 S.W.2d 247 (1984).

⁵³ Restatement (Second) of Torts, § 46(1) (1965).

⁵⁴ *Humana of Kentucky, Inc. v. Seitz, Ky.*, 796 S.W.2d 1, 2–3 (1990).

⁵⁵ *Kroger Co. v. Willgruber, Ky.*, 920 S.W.2d 61, 65 (1996).

⁵⁶ *Rigazio*, 853 S.W.2d at 299; *Brewer v. Hillard*, 15 S.W.3d at 7–8.

Check Your Understanding (2-5)

Question 1. The Kentucky court in *Banks* describes the tort of IIED as a “gap-filler.” With that in mind, which of the following is most likely to result in a successful IIED action in Kentucky:

An interactive H5P element has been excluded from this version of the text. You can view it online here: <https://saidtorts2d.lawbooks.cali.org/?p=44#h5p-36>

Question 2. True or False: Generally, courts allow recovery for humiliation and insults under IIED only when those produce either physical harm or include hateful speech (such as racist epithets or sexist treatment or other discriminatory comments).

An interactive H5P element has been excluded from this version of the text. You can view it online here: <https://saidtorts2d.lawbooks.cali.org/?p=44#h5p-37>

Question 3. In *Banks v. Fritsch*, which of the following facts, if true, weighs most heavily **against** a finding of false imprisonment? (Or, put another way, which of the following facts would you **rely on the most** if you were Mr. Fritsch’s attorney?)

An interactive H5P element has been excluded from this version of the text. You can view it online here: <https://saidtorts2d.lawbooks.cali.org/?p=44#h5p-38>

Hypothetical: Detained Shoppers

Mr. and Mrs. Bill and Kerry North packed their three children and Mr. North’s mother into their Ford Bronco and set out for the “Giant Liquidation Sale” held that day at Doe’s Department Store. When they arrived, they found the store quite disorganized and the merchandise displaced and picked-over. Nonetheless, their search for bargains began. Two dolly hand trucks caught the eye of Mr. North as he browsed through the store. Noticing that the hand trucks were being “eyed” by another shopper, Mr. North decided to purchase them while they remained available. The trucks each apparently bore two or more price tags, all showing identical prices of \$34.99 each. Mrs. North and her mother-in-law took money from Mr. North and purchased the dollies at the cashier’s line. The cashier totaled the prices, added tax, and then discounted the sale by fifty percent. The cashier gave Mrs. North a receipt and Mrs. North left the store with her mother-in-law and locked the dollies in the Bronco. They both returned to the store and Mrs. North gave the receipt and change from the purchase to her husband.

The Norths soon realized that the store management was paging the owner of a Ford Bronco (jeep). Mr. North went to see if there was a problem. He left Mrs. North and his mother behind to watch the children and to continue their shopping. Upon reaching the front of the store, Mr. North saw a police officer and asked whether anyone had hit his jeep. There, the store manager accused him of stealing merchandise. The manager threatened him with arrest if he did not return the goods. Mr. North stated that he did not know to what the manager was referring. The manager repeated the accusation and threat of arrest and Mr. North, finally understanding that the goods in question were the dollies, showed the manager the receipt and change his wife received for the purchase of the goods.

The store manager disregarded the receipt as being “impossible” because the dollies were not for sale, but rather were for use by store employees for transporting merchandise within the store. Mr. North pleaded with the officer not to arrest him as he had indeed purchased the goods and was not a thief. The manager, however continued his accusations of thievery while a number of customers formed small groups around the altercation that had now lasted some twenty minutes.

Attempting further to resolve this embarrassing matter, Mr. North explained that it had been his wife and mother who had purchased the dollies. The manager threatened to arrest them also. Mr. North asked the manager not to involve his wife because she was an outpatient at Forsyth Memorial Hospital and could not handle the aggravation and anxiety. Disregarding this warning, the manager, after spotting Mrs. North, confronted her and accused her of stealing the dollies. Mrs. North protested that she had paid for them, received a receipt, and placed the goods in the jeep. The manager, however, continued his accusations.

Mrs. North located the cashier who had received payment for the dollies. The manager again ignored the proffer of the receipt and the verification by the cashier of the sale. At this time, the officer took the Norths out to their jeep to look at the dollies. By the time they had returned, the Norths had been detained for some seventy-five minutes. Mr. North then asked for the names of the police officer, the store manager, and the cashier. The manager refused to give the names, stating that if the Norths “got the names, then they would be arrested.” The Norths left the store without the requested names. Their last memory of this episode was the manager’s reminder that they could be arrested for larceny anytime within the next year.

Instructions for this hypothetical practice: What intentional torts can Mr. and Mrs. North bring against the department store? Consider them as separate plaintiffs.

Note 1. Why do you think the hypothetical (drawn from an actual case) makes mention of the store’s disorganization, at the start of the facts?

Note 2. The Shopkeeper’s Privilege. Merchants and businesses, in generally, may avail themselves of a defense called the shopkeeper’s privilege that immunizes them against prosecution or litigation for false imprisonment. The hypothetical above comes from a case in North Carolina in which a trial court directed a verdict for the store. However, it was reversed on appeal and a judge found multiple grounds (including false imprisonment and others) on which the plaintiff and his wife could recover. *West v. King’s Dept. Store, Inc.*, (365 S.E.2d 621) (Sup. Ct. N.C. 1988). The case illustrates the variability of the shopkeeper’s privilege as well as the way that it can be defeated by conduct that appears to be malicious or egregious as the court ruled that a jury might find it to be on these facts.

Some jurisdictions have passed statutes to create robust immunity for detaining or questioning or searching a customer based on a reasonable belief that the customer may be shoplifting. The shopkeeper's privilege also exists at common law, where it grants an employee the authority of law to detain a customer to investigate the ownership of property in a reasonable manner and for a reasonable period of time, again only if the employee has reasonable belief that a customer has stolen or is attempting to steal store merchandise. These forms of immunity give merchants latitude to take actions that will sometimes be mistaken and may result in some embarrassment, hassles to innocent customers, or the experience of having one's person and property invaded or searched. The standard of reasonableness, is, of course, objective: the inquiry is whether it was reasonable for the shopkeeper to believe theft was imminent or underway, not whether the customer is guilty, or innocent (which would be a "subjective" standard, particularized to and provable about this customer). Why has the law used an objective standard for the shopkeeper's conduct, rather than a subjective standard about the customer?

Note 3. Optimally, the law would strike a balance between the store's right to protect its wares and the customer's right to freedom from unreasonable inquiries. Has the law found that balance, in your view, as a normative matter? What changes could tort law make? What effects would flow from any such changes? What other (non-legal) sorts of changes can you imagine being helpful here? Could such changes contribute more effectively to achieving greater balance between customers and stores?

Note 4. Recall the footnote in *Villa* about the ethnicity of the plaintiff and the mentions of Ms. Ali's being from Trinidad in *Ali v. Margate*. Would it have a bearing on your analysis if you knew the demographic identity of the Norths? How about the store manager and cashier? Would it matter to your analysis if the store were located in a wealthy part of town or a poorer one? What inferences would you draw from any of these details? Normatively, should tort law strive to flatten any differences or should its rules retain a focus on factual differences, case to case?

Chapter 11. IIED: A Deeper Dive (Socratic Script)

Questions or Areas of Focus for the Readings

- How does IIED fit with your understanding of the allocation of questions of law, versus fact?
- How does IIED fit with your understanding of the purpose and operation of the intentional torts overall?
- How might IIED advance or obstruct goals of racial and social justice?

Spicer v. Patnode, Court of Appeals of Washington, Div. 3 (2019) (9 Wash. App.2d 283)

*285 ¶ 1 Over the course of four months, Paul Patnode regularly and repeatedly remote-started his Ford F-250 pickup, revved its engine, and activated its alarm to scare Junghee Spicer’s young piano students as they walked past his truck on the way to their piano lessons. Mr. Patnode’s purpose was to interfere with Ms. Spicer’s piano lesson business and to cause her severe distress. He failed in his first objective, but accomplished the second. The trial court found in favor of Ms. Spicer on her claim of outrage and awarded her \$40,000.

¶ 2 The primary question we answer is whether Mr. Patnode’s conduct was sufficiently outrageous and extreme to sustain the trial court’s award. Conduct that is done infrequently merely to annoy a person cannot form the basis of an outrage claim. But the same conduct, done frequently over a period of weeks or months with the intent to cause severe emotional distress to a person, can form the basis of an outrage claim. We hold that Mr. Patnode’s conduct was sufficiently outrageous and extreme to present a question of fact. For this reason, we defer to the finder of fact and affirm.

FACTS⁵⁷

Background prior to purported tortious conduct

¶ 3 Paul and Melissa Patnode live across Lyle Loop Road from Junghee and David Spicer. In 2009, Ms. Spicer began teaching private piano lessons in her home, mostly to children. That year, Mr. Spicer suffered a stroke. Three years later, he had to retire early. To supplement their income, Ms. Spicer increased the number of piano lessons she taught.

¶ 4 In February 2012, Mr. Patnode complained to the Spicers about Ms. Spicer’s piano teaching business. Unable *286 to resolve the problems, Mr. Patnode complained to Yakima County. His complaints included increased traffic, damage to a sprinkler in his front yard, noise from car doors shutting and remotely locking, and headlights coming into his house.

⁵⁷ Mr. Patnode challenges 16 of the trial court’s findings of fact. Of these, 12 are quite nuanced and are unimportant to the issues on appeal. The remaining challenges, those to findings of fact 23, 32, 33, and 34, are specifically addressed below.

¶ 5 The complaints prompted Yakima County to require the Spicers to obtain a conditional use permit for their business. On July 11, 2012, the Spicers obtained a minor home occupation permit from Yakima County. The permit authorized Ms. Spicer to teach piano lessons for up to five students per day. Lessons were permitted from 2:00 p.m. to 6:00 p.m., Monday through Friday, September through May. The permit required the Spicers to provide off-street parking for customers.

¶ 6 In August 2012, Yakima County issued a modified permit that authorized Ms. Spicer to provide lessons for two additional months per year and increase the number of students to six per day. The Spicers were still required to provide off-street parking for customers.

¶ 7 Throughout 2012, Mr. Patnode continued complaining to Yakima County about Ms. Spicer's business. His complaints included Ms. Spicer teaching instruments other than piano and teaching outside the authorized hours. In addition, he complained that parents dropped their children off and picked them up along the street. He believed that this violated the off-street parking requirement.

¶ 8 In December 2012, Mr. Patnode sued the Spicers and alleged that their piano business violated the restrictive covenants that applied to the neighborhood. In 2014, the Spicers prevailed on summary judgment. Mr. Patnode was ordered to pay more than \$30,000 for the Spicers' attorney fees and costs.

¶ 9 In 2014, the city of Selah annexed the parties' neighborhood. Mr. Patnode began complaining to the city of Selah that Ms. Spicer continued to violate her modified permit. That year, the Spicers formed Yakima Arts Academy, LLC *287 (YAA). Ms. Spicer, through YAA, continued to teach piano lessons, both in her house and also in a leased building in Yakima.

Purported tortious conduct

¶ 10 From around Thanksgiving 2015 to March 24, 2016, Mr. Patnode parked his Ford F-250 diesel pickup along the sidewalk next to the Spicers' residence where piano students entered the Spicers' home. Other vehicles belonging to Mr. Patnode or his household also parked along the Spicers' side of the street.

¶ 11 During this time, Mr. Patnode regularly and repeatedly remote-started his F-250 and set off its alarm when Ms. Spicer's students and their parents walked by the F-250. Ms. Spicer observed this conduct approximately 12 times. When Ms. Spicer observed this conduct, it frightened her and her students. Mr. Spicer observed this conduct about six times.

Ms. Spicer's 2016 anti-harassment petition

¶ 12 In 2016, Ms. Spicer petitioned for an anti-harassment order against Mr. Patnode. Based on evidence presented at the anti-harassment hearing, the court granted Ms. Spicer's request and entered an anti-harassment order. The order prevented Mr. Patnode from parking vehicles on Ms. Spicer's side of the street and required him to disable the remote-start and alarm for his F-250. Mr. Patnode complied with the order.

This lawsuit [*sic*]

Partial grant of summary judgment for the Spicers

¶ 13 In May 2016, the Spicers filed this lawsuit against Mr. Patnode. They sought damages for intentional interference with their piano business and damages for intentional infliction of emotional

distress. Prior to trial, the Spicers moved for partial summary judgment. The motion sought to *288 preclude Mr. Patnode from disputing (1) his conduct had no legitimate or lawful purpose and (2) his conduct caused Ms. Spicer substantial emotional distress. The Spicers contended that these issues had already been litigated and necessarily decided when they obtained the anti-harassment order in March 2016. The trial court granted their motion.

Trial

¶ 14 At trial, Ms. Spicer testified that Mr. Patnode's conduct caused her severe emotional distress because she feared for her safety and the safety of her children and students. She explained that Mr. Patnode's remote-starting his truck scared her because she was concerned he would "go to the next step and actually physically harm somebody." Report of Proceedings at 131.

¶ 15 Ms. Spicer testified that Mr. Patnode caused her to suffer from anxiety and insomnia, and that she began taking anti-anxiety medication in 2013. At some point after Mr. Patnode began remote-starting his truck, Ms. Spicer began taking an additional anti-anxiety medication.

¶ 16 Two parents and one piano student testified about arriving for and leaving from piano lessons between Thanksgiving 2015 and March 24, 2016. They testified they observed Mr. Patnode's F-250 remotely starting, its engine revving, and its alarm activating on multiple occasions. One parent testified that this made her scared and concerned for her children's safety. One student testified that *every* time he had a piano lesson between those dates, he observed the F-250 remotely start, its engine rev loudly, and its alarm activate. The parents did not take their children out of piano lessons with Ms. Spicer, and the student who testified did not quit taking lessons from Ms. Spicer.

¶ 17 The trial court found that Mr. Patnode did not cause any loss of business to the Spicers. The court, however, did find that Mr. Patnode's conduct was sufficiently outrageous to constitute intentional infliction of emotional distress. *289 The trial court further found that Ms. Spicer, but not Mr. Spicer, had proved compensable damages.

¶ 18 The trial court entered the following findings of fact to which Mr. Patnode assigns error:

23. In 2016, Ms. Spicer filed a petition for an anti-harassment order against Mr. Patnode. The Court takes judicial notice that following a hearing, the Yakima County Superior Court orally concluded that Mr. Patnode was remotely starting his F-250 and setting off vehicle alarms and doing so on purpose repeatedly for the purpose of harassing the Spicers, making their lives more difficult.⁵⁸ . . .

32. Junghee Spicer suffered severe emotional distress as a result of Mr. Patnode parking vehicles on the street alongside the Spicers [sic] house from Thanksgiving 2015 to March 24, 2016, and regularly and repeatedly remote starting his F-250 pickup (which included revving the engine, lights turning on) and remotely setting off the vehicle alarm while it was parked on the street alongside the Spicers' house, where children/students and their parents were walking to and from lessons at the Spicers' residence.

⁵⁸ Mr. Patnode persuasively argues that the trial court erred by taking judicial notice of the previous court's oral ruling. *See State v. Hescocock*, 98 Wash. App. 600, 606, 989 P.2d 1251 (1999). We give no weight to finding of fact 23. This does not impair the same findings contained in finding of fact 32, subject to those findings being supported by substantial evidence.

33. The conduct of Mr. Patnode described above was directed towards Ms. Spicer. Mr. Patnode sought to interfere with the Spicers' music business. Ms. Spicer was the direct recipient of Mr. Patnode's conduct even though she was not present for, and did not observe, all instances when Mr. Patnode remote-started his F-250 or remotely set off the vehicle alarm when students and/or parents were walking to or from piano lessons.

34. Ms. Spicer was fearful for her safety and for the safety of her students. ... Ms. Spicer suffered insomnia and anxiety as a result of Mr. Patnode's conduct. Ms. Spicer began taking anti-anxiety medication in 2013. At some time after the remote-start/alarm incidents described above, Ms. Spicer began to take *290 one additional anti-anxiety medication. At the time of trial Ms. Spicer was also taking a third anti-anxiety medication.

Clerk's Papers (CP) at 322-26.

¶ 19 In addition, the trial court entered the following conclusion of law, to which Mr. Patnode also assigns error:

6. Mr. Patnode's conduct ... was outrageous conduct. *Ms. Spicer was the object of Mr. Patnode's course of conduct. Mr. Patnode's conduct was directed at Ms. Spicer through her piano students and their parents. Mr. Patnode's object was to interfere with the teaching business and cause distress to Ms. Spicer.* Mr. Patnode's conduct went beyond all possible bounds of decency, and was atrocious and utterly intolerable in a civilized society. *Mr. Patnode's conduct was intentional, he knew it would cause or inflict Ms. Spicer with emotional distress, and his conduct in fact caused Ms. Spicer severe emotional distress.* CP at 327-28 (emphasis added).

¶ 20 The trial court awarded Ms. Spicer \$40,000 in damages.

¶ 21 Mr. Patnode timely appealed. A panel of this court granted oral argument, which occurred at Whitman College, in Walla Walla, Washington.

*806 ANALYSIS

¶ 22 Mr. Patnode makes three arguments:

- (1) conduct that Ms. Spicer or her immediate family members did not observe cannot form the basis of Ms. Spicer's outrage claim,
- (2) his conduct does not rise to the level of extreme and outrageous conduct as a matter of law, and
- (3) substantial evidence does not support the trial court's finding that Ms. Spicer suffered severe emotional distress.

We address the issues in the order argued by Mr. Patnode.

EVIDENCE NOT DIRECTLY WITNESSED BY MS. SPICER

¶ 23 Mr. Patnode argues the trial court erred by considering evidence not directly witnessed by Ms. Spicer or her *291 immediate family members. His argument implies that his conduct was directed at the young piano students.

¶ 24 When the outrageous conduct is directed at a third person, the plaintiff must be an immediate family member of the person who is the object of the defendant's action, and he must be present at the

time of the conduct. *Grimmsby v. Samson*, 85 Wash.2d 52, 60, 530 P.2d 291 (1975) (citing RESTATEMENT (SECOND) OF TORTS § 46 cmt. 1 (AM. LAW INST. (1965))). This rule has no application here, where the outrageous conduct was directed at Ms. Spicer rather than at a third person.

¶ 25 Here, the trial court found:⁵⁹

Ms. Spicer was the object of Mr. Patnode's course of conduct. Mr. Patnode's conduct was directed at Ms. Spicer through her piano students and their parents. Mr. Patnode's object was to interfere with the teaching business and cause distress to Ms. Spicer.

¶ 26 The above finding is well supported by the evidence. For years, Mr. Patnode sought to substantially prevent, Ms. Spicer from teaching piano lessons at her house. He began by acting within the legal process. He first complained to Ms. Spicer, later he complained to Yakima County, and still later he complained to the city of Selah. When these complaints failed, he brought a lawsuit to prevent Ms. Spicer from teaching piano lessons out of her house. He alleged that Ms. Spicer's piano lesson business violated the neighborhood's restrictive covenants. The Spicers had that lawsuit dismissed and were awarded their reasonable attorney fees.

¶ 27 Shortly after, Mr. Patnode began acting outside the legal process. Mr. Patnode began scaring Ms. Spicer's young *292 piano students by remote-starting his F-250, revving its engine, and activating its alarm. The young students, walking by his truck, did nothing to warrant being scared. In fact, Mr. Patnode testified he did not remote-start his truck for the purpose of scaring the piano students or their parents. The trial court reasonably found that Mr. Patnode's conduct was not directed at the young piano students, but instead was directed through them to Ms. Spicer. Because Mr. Patnode's conduct was directed at Ms. Spicer, the trial court did not err by considering evidence not directly witnessed by Ms. Spicer.

EXTREME AND OUTRAGEOUS CONDUCT

¶ 28 Mr. Patnode argues, as a matter of law, his conduct does not amount to extreme and outrageous conduct.

¶ 29 To constitute outrage, the conduct at issue "must be 'so outrageous in character, and so extreme in degree, as to go beyond all possible bounds of decency, and to be regarded as atrocious, and utterly intolerable in a civilized community.'" [cc] ("Consequently, the tort of outrage 'does not extend to mere insults, indignities, threats, annoyances, petty oppressions, or other trivialities.' In this area plaintiffs must necessarily be hardened to a certain degree of rough language, unkindness and lack of consideration." [cc])

¶ 30 In order to prevail on a claim of intentional infliction of emotional distress, the plaintiff must show (1) extreme and outrageous conduct, (2) intentional or reckless infliction of emotional distress, and (3) actual result to plaintiff of emotional distress. [c] The claim is also known as the tort of outrage. "Although the three elements are fact questions for the jury, th[e] first element *293 of the test goes to the jury only after the court 'determine[s] if reasonable minds could differ on whether the conduct was sufficiently extreme to result in liability.'" [cc]

⁵⁹ This finding comes from the trial court's conclusion of law 6. To the extent a conclusion of law contains a finding of fact, an appellate court will treat it as a finding of fact. *Hegwine v. Longview Fibre Co.*, 162 Wash.2d 340, 353, 172 P.3d 688 (2007).

¶ 31 We examine Washington decisions⁶⁰ to determine what type of conduct is sufficiently outrageous and extreme to impose liability on an actor. Mr. Patnode cites *Strong v. Terrell*, 147 Wash. App. 376 (2008) and *Snyder v. Medical Service Corporation of Eastern Washington*, 98 Wash. App. 315 (1999), *aff'd*, 145 Wash.2d 233 (2001) for the proposition that inflicting emotional harm on another over a period of months is insufficient to meet the high standard of outrageousness. In both cases, the plaintiff employees were subject to demeaning and insulting verbal treatment by their supervisors over a period of months. *Strong*, 147 Wash. App. at 381; *Snyder*, 98 Wash. App. at 319. Both courts noted that liability for outrage does not extend to treatment akin to “mere insults, indignities, threats, annoyances, petty oppressions, or other trivialities.” *Snyder*, 98 Wash. App. at 321-22 (internal quotation marks omitted) (quoting *Grimbsby*, 85 Wash.2d at 59); *accord Strong*, 147 Wash. App. at 386. The courts reviewed the supervisors’ treatment of their respective employees, determined that the treatment did not rise above insults, threats, and trivialities, and concluded that no liability existed. *Strong*, 147 Wash. App. at 386-87; *Snyder*, 98 Wash. App. at 322.

¶ 32 Mr. Patnode next cites *Saldivar v. Momah*, 145 Wash. App. 365 (2008) to further support the proposition that inflicting emotional harm on another over a period of months is insufficient to meet the high standard *294 of outrage. In that case, a woman and her husband fabricated allegations of sexual abuse against a physician and filed a lawsuit against him alleging that he sexually abused her. *Id.* at 390. The trial court dismissed the plaintiffs’ claims after they rested, finding that the sexual abuse claim was not credible and that the purported victim had lied on the stand. *Id.* at 383-84. The trial court also found that the attorney for the plaintiffs filed “irrelevant and salacious declarations ... for the improper purpose of eliciting media/public attention, to harass and damage the reputation of Dr. Momah, and to ... gain advantage in other litigation.” *Id.* at 386. Due to plaintiffs’ false claims and their attorney’s actions, Dr. Momah lost his job, suffered a stroke, and was uninsurable and unemployable. *Id.* at 384. The trial court awarded Dr. Momah substantial damages on his outrage claim against the plaintiffs and their attorney. *Id.* at 385. The appellate court reversed and concluded that the conduct was insufficient to constitute outrage. *Id.* at 390.

¶ 33 We contrast *Saldivar* with *Phillips v. Hardwick*, 29 Wash. App. 382 (1981). There, the Phillips agreed to purchase the Hardwicks’ house and entered into an earnest money agreement. *Id.* at 384. The Hardwicks later learned that their new house would not be ready until shortly after the agreed closing date of November 25. The Phillips agreed to rent the house to the Hardwicks until December 1. The Hardwicks did not vacate as agreed. On December 2, the Hardwicks told the Phillips that because they were tenants, the Phillips were powerless to remove them. The Phillips drove by the house on December 3. They looked inside, noticed the furniture was gone, and arranged to move in the following day. The next day, when they arrived with a carload of furniture, the Hardwicks initially prevented them from moving in. When the Phillips returned with a second carload, they noticed two deputy sheriffs. *Id.* at 384-85. The deputies determined that the *295 Phillips had the right of possession and advised the Hardwicks of this, yet the Hardwicks refused to leave. *Id.* at 385. The next day, the Phillips commenced two lawsuits. The first lawsuit was an unlawful detainer, and the second lawsuit sought damages on various theories, including intentional infliction of emotional distress. The Hardwicks moved out a few days later and gave the keys to the Phillips. In the second lawsuit, the trial court found

⁶⁰ Each party cites several cases from other jurisdictions in support of their arguments. As shown below, even Washington cases are inconsistent on what type of conduct is sufficiently egregious to constitute outrage. It is, therefore, unsurprising that the out-of-state cases discussed by the parties and the dissent are inconsistent and unhelpful.

in favor of the Phillips and awarded them over \$11,000. *Id.* at 383. On appeal, the trial court affirmed the damages award on the basis that reasonable minds could differ as to whether the Hardwicks' conduct was sufficiently outrageous. *Id.* at 388-89.

¶ 34 We cannot reconcile *Saldivar* with *Phillips*. *Saldivar* involved extreme conduct that caused extensive emotional and financial damages. Yet, the appellate court reversed the trial court's finding of outrage. *Phillips* involved a few days' delay in occupancy that caused a mere annoyance to a home purchaser. Yet, the appellate court affirmed the trial court's finding of outrage. We disagree with both decisions.

¶ 35 We find support for our disagreement in *Wolf v. Scott Wetzel Servs., Inc.*, 113 Wash.2d 665 (1989), which appears to take a middle approach. There, Mr. Wolf lifted a heavy timber at work and injured his lower back. *Id.* at 667. He filed a workers' compensation claim. His employer was self-insured, and Mr. Wolf's claim was administered by Scott Wetzel Services, Inc. (SWS). Mr. Wolf received time loss and medical payments. About six months after the injury, SWS learned from Mr. Wolf's attending physician that Mr. Wolf could return to work. As a consequence, SWS closed Mr. Wolf's claim. A few months later, Mr. Wolf and his new physician requested the claim to be reopened on the basis that the lower back injury "may have contributed to psychological problems." SWS denied the request. Mr. Wolf appealed the denial and the denial eventually was reversed. Mr. Wolf *296 brought suit against SWS alleging bad faith denial of his claim and outrage.

¶ 36 In denying Mr. Wolf's outrage claim, our high court explained:

As illustrative of what constitutes [outrage], ... [i]n [an appellate case from California], it was alleged that an investigator hired by the insurance carrier befriended the claimant, misrepresenting his true capacity and intentions. Then, during an excursion to Disneyland, the investigator enticed the claimant into crossing a rope bridge and engaging in other physically demanding activities. Unbeknownst to the claimant, another investigator filmed her while she did so. Upon discovering at a subsequent hearing how she had been deceived, the claimant suffered a physical and mental breakdown requiring hospitalization. We agree that such conduct is indeed outrageous under the standard adopted by this court.

The same cannot be said for the conduct involved in the present case. ... The facts ... in the present case in no way suggest that the claims administrator for the self-insured employer engaged in conduct that could constitute the tort of outrage. Furthermore, ... Mr. Wolf is alleging only "bad faith" in the administration of his workers' compensation claim. *Id.* at 678-79⁶¹ (footnote omitted).

¶ 37 As the cases reflect, what constitutes outrage is nebulous and difficult to define. But three things are clear. First, to impose liability, the law requires the conduct to be so outrageous in character, and so extreme in degree, as to go beyond all possible bounds of decency as to be utterly intolerable in a civilized community. [c] Second, liability may not be imposed for mere insults, indignities, threats, annoyances, petty oppressions, or other trivialities. *Strong*, 147 Wash. App. at 386; *Snyder*, 98 Wash.

⁶¹ The Wolf court's analysis comports with the various illustrations contained in the Restatement (Second) of Torts § 46. Whereas the conclusions reached in the intermediate appellate decisions in *Strong* and *Snyder* do not comport with the illustrations.

App. at 321-22. And third, somewhere between these standards, *297 the question of liability passes from a court of law to the trier of fact. *Robel*, 148 Wash.2d at 51.

¶ 38 Had Mr. Patnode remote-started his truck occasionally to scare passing piano students, this would not be actionable. Rather, it would constitute a mere annoyance—a triviality. But this is not what Mr. Patnode did. Instead, he engaged in a course of conduct over a period of four months intending to cause Ms. Spicer sufficient emotional distress so she would stop teaching piano lessons at her house. He intended to achieve through harassment what he had been unable to achieve through legal means. In order to achieve his purpose, he knew he had to cause Ms. Spicer severe emotional distress. And he did.

¶ 39 The dissent classifies this conduct as merely childish. We disagree. The conduct—because it occurred frequently over a period of months—clearly exceeds insults, indignities, threats, annoyances, petty oppressions, or other trivialities. We believe a trier of fact could consider the conduct to be so outrageous in character, and so extreme in degree, as to be utterly intolerable in a civilized community. For this reason, the question of liability passes from us to the trier of fact.

3. SEVERE EMOTIONAL DISTRESS

¶ 40 Mr. Patnode argues substantial evidence does not support the trial court’s finding that Ms. Spicer suffered severe emotional distress. We disagree.

¶ 41 We will not overturn a trial court’s finding of fact if it is supported by substantial evidence. [c] Substantial evidence is that amount of evidence sufficient to persuade a fair-minded person that a given premise is the truth. [c]

¶ 42 To prevail on an outrage claim, a plaintiff must show that he or she actually suffered severe emotional distress as a result of the defendant’s conduct. *298 [c] Mr. Patnode first argues that regularly and repeatedly remote-starting his F-250 over the course of four months, revving its engine, and activating its alarm could not have caused a reasonable person to suffer severe emotional distress. We disagree. It was Mr. Patnode’s objective to cause Ms. Spicer to suffer sufficient emotional distress so she would stop teaching piano lessons at her house. This objective could not be accomplished by mere insults, indignities, threats, annoyances, petty oppressions, or other trivialities. Mr. Patnode’s argument that Ms. Spicer could not have suffered severe emotional distress runs counter to his objective. If he did not think his conduct would accomplish his objective, he would not have engaged in it.

¶ 43 Mr. Patnode next argues no one could believe his conduct could reasonably cause Ms. Spicer to fear for her safety. We disagree. One of the parents testified that Mr. Patnode’s conduct made her scared and concerned for her children’s safety.

¶ 44 Mr. Patnode, citing *Sutton v. Tacoma School District No. 10*, 180 Wash. App. 859 (2014), argues that Ms. Spicer’s symptoms of stress and insomnia were insufficient to constitute extreme emotional distress. There, a teacher pinned a first grade special education student against the wall and cornered her by chest-bumping her while yelling insults at her. *Id.* at 863. The child’s grandmother witnessed the incident. She testified that the child was scared, angry, sad, and mad, and did not want to return to the teacher’s class. *Id.* at 872. We held that this evidence was sufficient to constitute emotional distress. However, there was no evidence of how long the emotional distress lasted. Because actionable outrage

requires emotional distress that is more than transient, we affirmed the trial court's summary judgment. *Id.* at 874.

¶ 45 *Sutton* is distinguishable. Here, Ms. Spicer suffered emotional distress throughout Mr. Patnode's four-month course of conduct.

*299 ¶ 46 Affirmed.

[Dissent] Korsmo, J.

Outrageous conduct is conduct "which the recitation of the facts to an average member of the community would arouse his resentment against the actor and lead him to exclaim 'Outrageous!'" *Reid v. Pierce County*, 136 Wash.2d 195, 201-02 (1998) (quoting *Browning v. Slenderella Sys.*, 54 Wash.2d 440, 448 (1959) (quoting RESTATEMENT (SECOND) OF TORTS § 46(g) (AM LAW INST. 1965))). As the court more recently stated:

The conduct must be "so outrageous in character, and so extreme in degree, as to go beyond all possible bounds of decency, and to be regarded as atrocious, and utterly intolerable in a civilized community." [cc]

¶ 47 The main element of an outrage claim is, of course, outrageous behavior. Remote starting a car or setting off a car alarm when someone is walking past simply is not atrocious conduct, nor is it "utterly intolerable in a civilized community." Mr. Patnode's behavior was juvenile, childish, oafish, puerile, immature, infantile, and lame. It would not have even qualified as a bad junior high school prank in a less sophisticated time. He was annoying, but he was not outrageous.

¶ 48 Washington requires more than this simplistic behavior to satisfy the threshold requirements for the tort of *300 intentional infliction of emotional distress. The definition of the tort is found in RESTATEMENT § 46:⁶²

(1) One who by extreme and outrageous conduct intentionally or recklessly causes severe emotional distress to another is subject to liability for such emotional distress, and if bodily harm to the other results from it, for such bodily harm.

(2) Where such conduct is directed at a third person, the person is subject to liability if he intentionally or recklessly causes severe emotional distress

(a) to a member of such person's immediate family who is present at the time, whether or not such distress results in bodily harm, or

(b) to any other person who is present at the time, if such distress results in bodily harm.

Ms. Spicer's action proceeded under § 46(2)(b), meaning that she had to show that outrageous conduct directed at third persons in her presence resulted in bodily harm. While the remaining elements were established, the outrageous conduct element was not. She failed to meet the required threshold showing. *Jackson v. Peoples Federal Credit Union*, 25 Wash. App. 81, 84 (1979).

¶ 49 In *Jackson*, the plaintiff sued in outrage because the credit union had attempted to repossess his car at his place of work after a dispute arose over loan repayment; the incident aggravated his diabetes,

⁶² No Washington court has applied the Restatement (Third) of Torts § 46, so, like the majority, I will confine my remarks to the Restatement (Second). It should be noted that comment i in the Second Restatement is now found as comment h in the Third Restatement.

a condition known to the credit union. *Id.* at 83-84. Division Two of this court rejected the outrage claim, determining that the behavior of the credit union failed to meet the “extreme and outrageous” standard of the tort. *Id.* at 84 (quoting RESTATEMENT § 46 cmt. h).

¶ 50 Proof of outrageous behavior is the *sine qua non* of this tort. There is no exception for the intentional infliction *301 of distress by nonoutrageous behavior. While the steady dripping of small amounts of water may erode a foundation just as effectively as a deluge, this tort is only concerned with the latter possibility. Behavior must be beyond the pale to be actionable.

¶ 51 Our case law long has reached that same conclusion. Infliction of emotional distress by intentional behavior is by itself inadequate to establish this tort. We have found far more offensive behavior than noisy car alarms and remote vehicle starting *insufficient* to establish outrageous behavior. *E.g.*, *Repin v. State*, 198 Wash. App. 243 (2017) (holding that veterinarian’s unsuccessful attempt at euthanasia, failure to warn of risks, and the dog’s immense suffering not sufficiently outrageous); *Christian v. Tohmeh*, 191 Wash. App. 709, 737-38 (2015) (doctors; course of conduct—obfuscation of plaintiff’s diagnosis, yelling and shouting at her and telling her problems were in her head; telling other doctors that her emotional issues made her history less valid—insufficient to meet the “extremely high” standard of outrage); *Strong v. Terrell*, 147 Wash. App. 376, 388-89 (2008) (finding conduct insufficient where coworker told blonde jokes, ridiculed plaintiff’s personal life, called her a bum, and made other disparaging remarks over the course of several years). *Saldivar v. Momah*, 145 Wash. App. 365 (2008) (holding that filing suit against physician with malicious intent is not “utterly intolerable in a civilized community”).

¶ 52 While no prior Washington case has been based on car noises, a couple of Ohio cases have rejected the notion that such behavior is outrageous. *Krlich v. Clemente*, 2017-Ohio-7945, 98 N.E.3d 752, 757, 759 (Ct. App.) (finding car horn honking “at all hours of the day and night,” alleged lewd gestures, and more (such as paintballing plaintiff’s home and driving on their lawn) not sufficiently extreme and outrageous for intentional infliction of emotional distress); *302 *Allen v. Pirozzoli*, No. 103632, 2016-Ohio-2645, 2016 WL 1600344 (Ct. App. Apr. 21, 2016) (unpublished) (conduct of setting off fireworks, standing in his driveway when plaintiff would pull in the driveway, horn honking, banging on fence and windows, revving motorcycle in front of plaintiff’s house insufficient to establish outrageousness).⁶³

¶ 53 Mr. Patnode is clearly a bad neighbor, but he also is bad at being an outrageous one. Although the trial court’s desire to punish him for his conduct is understandable, and appreciated by this writer, that conduct simply does not make the grade for the tort of outrage. He intentionally inflicted emotional distress, but did so in a bland enough manner that this particular claim was not actionable. This was harassment pure and simple. Since the majority rewrites the tort of intentional infliction of emotional distress by treating the outrageous conduct element as a question of fact for the trier-of-fact, I respectfully dissent.

⁶³ Unpublished Ohio opinions may be cited as authority in that state. See OHIO SUP. CT. REP. OP. R. 3.4. Thus, they may be relied on in this state. GR 14.1(b).

Note 1. Are you more persuaded by the majority or dissenting opinion? What do you observe about their uses of precedent?

Note 2. At least one scholar has called for a sex-based approach to understanding emotional harm in the context of tort law. Betsy J. Grey, *Sex-Based Brain Differences and Emotional Harm*, 70 *Duke L.J. Online* 29, 55–56 (2020) Grey cautions against biological determinism (which is a phrase conveying the idea that people are the way they are based on their biological or genetic composition, which in the context of gender would mean a narrow understanding of gender as defined by biological sex). Grey surveys feminist approaches to tort law including the success of the “reasonable woman” standard successfully introduced in hostile workplace litigation. In spite of her cautions, she concludes on a note of optimism about the viability of future uses of scientific evidence to demonstrate biological differences with respect to gender and emotional harm which, she argues, could potentially possess legal relevance. Another scholar has advocated for uses of biological theories of behavior and trauma to ground IIED in objectively verifiable experiences. Cristina Carmody Tilley, *The Tort of Outrage and Some Objectivity About Subjectivity*, 12 *J. Tort L.* 283, 291 (2019).

Note 3. Does IIED need to be “reined in” in your view? Or is it serving its purpose as the last-added intentional tort aiming to capture different kinds of harms? One scholar has described IIED as more accurately understood as a “family of torts loosely captured through the notion of outrageous conduct” than a single tort. Benjamin C. Zipursky, *Snyder v. Phelps, Outrageousness, and the Open Texture of Tort Law*, 60 *DePaul L. Rev.* 473, 503 (2011) Do you agree?

Expand On Your Understanding – Socratic Script: Spicer v. Patnode

Question 1. What was the legal issue in this case? How would you formulate the rule?

An interactive H5P element has been excluded from this version of the text. You can view it online here: <https://saidtorts2d.lawbooks.cali.org/?p=46#h5p-39>

Question 2. What was the holding in this case?

An interactive H5P element has been excluded from this version of the text. You can view it online here: <https://saidtorts2d.lawbooks.cali.org/?p=46#h5p-40>

Question 3. The majority writes that “what constitutes outrage is nebulous and difficult to define. But three things are clear.” What are those three things, and how do they relate to the facts of this case? How does that relate to the holding?

An interactive H5P element has been excluded from this version of the text. You can view it online here: <https://saidtorts2d.lawbooks.cali.org/?p=46#h5p-41>

Question 4. The tort of outrage has 3 elements in Washington state:

- (1) extreme and outrageous conduct,
- (2) intentional or reckless infliction of emotional distress and
- (3) “actual result to plaintiff of emotional distress.”

All three elements are questions of fact yet the court nonetheless reviews Mr. Patnode’s conduct in light of the legal standard and surveys the cases in Washington state. It does so even though it generally accepts the findings of fact of the lower court. Why?

An interactive H5P element has been excluded from this version of the text. You can view it online here: <https://saidtorts2d.lawbooks.cali.org/?p=46#h5p-42>

Question 5. Please briefly summarize the dissent’s argument from *Spicer*. Where the dissent relies on *Jackson v. Peoples Federal Credit Union*, what is the analogy that it attempts to draw? Is that analogy persuasive? Why or why not?

An interactive H5P element has been excluded from this version of the text. You can view it online here: <https://saidtorts2d.lawbooks.cali.org/?p=46#h5p-43>

Reflect On Your Understanding – Spicer v. Patnode

The town of Selah, Washington, where parts of the dispute took place, recently came under fire for allegedly not being welcoming to people of color. In the wake of Black Lives Matter protests in the summer of 2020, town residents clashed over the ability to express messages of solidarity in sidewalk chalk: <https://www.nytimes.com/2020/07/16/us/sidewalk-chalk-police-selah-washington.html>

If it turned out to be true that the region was historically inhospitable to people of color, would that be relevant to your analysis of the facts in *Spicer v. Patnode*? How and why if so?

Chapter 12. Trespass to Chattels and Conversion

Elements of Trespass to Chattels

- Intent
- To use or intermeddle with the chattel of another or to dispossess the other of their chattel
- Without permission or justification, and which
- Causes harm to or destruction of the chattel or causes a substantial interference with the possessor's use of the chattel

Elements of Conversion

- Intent
- To exercise dominion or control over a chattel
- Which dispossesses or deprives its owner permanently or indefinitely

“**Chattels**” means “**personal property**” (as opposed to “real property” like land or intellectual property like patents, copyright or trademarks). Chattels include animals: the law treats pets as well as livestock as chattels. Chattels do not include cash; generally, chattels are “things.”

The trespass in the tort's name refers to the intentional use of another's chattel or interference without permission or justification for the use or interference, resulting in destruction or demonstrable harm. The tort of conversion conceptualizes the harm more broadly: it is the *ownership* interest that has been violated because the defendant has “exercised control” over the plaintiff's property.

The tort of **trespass to chattels** is somewhat similar to the interest we protect through battery: a right to be free from physical invasions, except the interest here is narrower. Recall that battery did not require proof of harm and even a “beneficial” invasion could be a battery if unconsented. The interest protected through battery was the inviolability of the body. Similarly, the interest protected through the tort of trespass to land is the inviolability of the ownership of land. **Conversion** is more similar to battery and trespass to land in that protects a broader interest than mere harm to stuff: it protects the inviolability of one's ownership right. Consequently, a plaintiff who can show that their ownership right has been interfered with in the defendant's exercising control over the plaintiff's chattel will not have to prove harm. Just as was the case with battery, making out the elements proves the invasion of the interest and it is the invasion of the interest that constitutes the harm.

The **intent** required for both of these personal property torts is **similar to the intent for battery**: simply using or “interfering” with the chattel, even without any knowledge that one is interfering with another's possessory interest, is enough; specific intent to invade another's interest is not necessary. (Distinguish this from false imprisonment, which requires the specific intent to confine.) The trespassory use must be substantial; it would trivialize the judicial system if mere annoyances over objects of common use were litigable.

Trespass to chattels is sometimes helpful in pursuing a claim for another's intentionally harming one's animals. However, when serious damage to personal property, including animals, occurs, the tort of conversion is the usually the more appropriate action to bring and as a matter of practice, the two torts are often brought together as alternative theories of liability. While conversion requires a higher showing with regard to the defendant's conduct, if the plaintiff can successfully plead it, the plaintiff need not prove harm. By contrast, to succeed in an action for trespass to chattels, *the plaintiff must prove the alleged harm or destruction to the chattels*. Note that causing the value of the chattel to drop counts as "harm" to the chattel. The plaintiff can recover for all the harm to the chattel and incidental damages the unauthorized use causes. The measure of damages is the market value at the time of the dispossession or intermeddling.

For example, if a person borrows their roommate's car without permission and returns it safely without damage, there has been no trespass to chattels so long as the owner did not suffer as a result of not having it available during the time of the roommate's use. Trespass to chattels would require that the driver harm the car or that the owner *need* the car and be unable to use it during the specified time of the unauthorized use. If the owner needed it for some purpose and had to take a cab instead of driving, for instance, or missed an opportunity for a job interview, the damages from the tort could compensate for those harms even if the car was not damaged.

**Grosch v. Tunica County, Mississippi et al, U.S. District Court, N.D. Miss.,
Delta Div. (2008)
(569 F. Supp.2d 676)**

[Adam Grosch, a gambler, brought claims of trespass to chattels and conversion against the Hollywood Casino Corporation, where he had been a patron, and the Mississippi Gaming Commission; the Commission moved to dismiss the plaintiff's claims for lack of subject matter jurisdiction pursuant to Fed. R. Civ. P. 12(b)(1) arguing that such claims are within the exclusive jurisdiction of the Mississippi Gaming Commission pursuant to Mississippi statutes.]

"The difference between trespass to chattels and conversion is primarily one of degree. Trespass to chattels in modern tort law involves interference or damage that is of a less serious or substantial nature. Conversion claims involve substantial interference or damage. Otherwise the elements are the same. Conversion is by far the more important of the two torts." [c] To prevail on a claim of trespass to chattels, a plaintiff "must establish *678 that there has been an unauthorized interference with his possession of personal property, or an unauthorized use of his personal property." [c] "If the interference is of such a substantial nature that the defendant can justly be compelled to pay the entire value of the chattel, the plaintiff's remedy is an action for conversion." [c] "[T]here is a conversion only when there is an 'intent to exercise dominion or control over goods which is inconsistent with the true owner's right.' While intent is necessary, it need not be the intent of a wrongdoer." [c]

The Second Amended Complaint does not specifically delineate the plaintiff's case theory regarding his claims for trespass to chattels and conversion. The court surmises from the factual background and the briefs that the plaintiff alleges that the defendants exercised dominion and control over his property—*i.e.*, the money that is represented by the casino chips he undisputedly won—which were inconsistent with his ownership rights because the defendants would not cash in his chips unless and

until the plaintiff handed over his driver's license to the casino. The plaintiff argues that the defendants had no right to require that he relinquish dominion and control of his ID to the casino for any purpose other than simply verifying his identity.

In the instant motion, the Hollywood Casino characterizes the dispute as one wherein the plaintiff looked to be under twenty-one years of age and that they simply wanted his ID to verify his age. The plaintiff argues that they already knew he was over twenty-one, since he had a player's card and would not have been allowed in the area where he gambled. Furthermore, the plaintiff alleges that he did not refuse to prove his age by showing his ID but rather refused to physically give it to the casino because he feared they would copy his ID and send it to other casinos as a warning that the plaintiff was a card counter.

Hollywood's primary argument is that the claims of trespass to chattels and conversion should be dismissed because they are within the exclusive jurisdiction of the Mississippi Gaming Commission since they involve a "claim by a patron ... for payment of a gaming debt" pursuant to § 75-76-157(2) of the Mississippi Gaming Control Act. Hollywood cites *Grand Casino Tunica v. Shindler*, 772 So.2d 1036, 1038 (Miss. 2000) for the proposition that the Mississippi Gaming Commission has exclusive jurisdiction over "all gaming matters" and that the trespass to chattels and conversion claims are "gaming matters."

The court disagrees. [***] The Mississippi Supreme Court has recently indicated that "all gaming matters" means "gaming debts" in relation to § 75-76-157. In *Ameristar Casino Vicksburg, Inc. v. Duckworth*, 990 So.2d 758, 2008 WL 2447274 (Miss. June 19, 2008), the Court concluded that a dispute involving a raffle at a casino was not within the jurisdiction of the Mississippi Gaming Commission because the dispute did not involve a game of gambling or a "gaming debt" pursuant to § 75-76-157. [***] If Hollywood were correct that the gaming commission enjoys exclusive jurisdiction over "all gaming matters" when defined expansively as "any dispute that would not exist but for participation in gambling," then, in theory, all of the plaintiff's remaining Mississippi-law causes of actions—*i.e.*, false arrest, false imprisonment, abuse of process, and malicious prosecution—would also be within the exclusive jurisdiction of the gaming commission. Section 75-76-157(2) by its plain language clearly does not indicate this. Rather, it confines its reach to claims involving payment of gaming debts.

The plaintiff in the instant case argues that his trespass to chattels and conversion claims are not claims for gaming debts since he is not asserting "[a] claim ... for payment of a gaming debt" per § 75-76-157(2) because he in fact received his money. Rather, the focus of his claims, he argues, is on the unlawful withholding of his undisputed winnings unless and until he turned over his other personal property—*i.e.*, his identification—to the control and dominion of the defendants. The plaintiff alleges that he never agreed to hand over his ID to the casino and they would not have received and copied it but for the actions of the Tunica County Sheriff's Department in taking his ID from him.

The court is persuaded that this understanding of the plaintiff's trespass to chattels and conversion claims takes them out of the realm of seeking payment for a gaming debt. Therefore, the gaming commission does not have exclusive jurisdiction over these claims pursuant to § 75-76-157(2).

[***] Motion to dismiss the plaintiff's claims for trespass to chattels and conversion for lack of subject matter jurisdiction pursuant to Fed.R.Civ.P. 12(b)(1) is DENIED.

Note 1. What is the chattel with respect to which the plaintiff alleges he has been dispossessed?

Note 2. At trial, Grosch did indeed prevail on his personal property claims. However, he also brought numerous claims against the casino as well as the County, including violation of his Fourth and Fourteenth Amendment rights pursuant to 42 U.S.C. § 1983 as well as claims of false arrest, false imprisonment, abuse of process, malicious prosecution and violation of state constitutional rights. Grosch was able to provide evidence that the casino and the Sheriff routinely engaged in some form of collusion involving the stratagem of the casino's refusing to hand over winnings unless players yielded their ID cards and the casino and Sheriff unlawfully detaining players.

The jury found the Hollywood Casino was liable for conversion and trespass to chattels and awarded \$925.00, the cash value of the chips Grosch had won and that the casino had refused to cash for him unless he handed over his license. The award was upheld on appeal even though by that point Grosch had recovered his ID and had received the value of his chips. The award was given to reflect the interference with his possessory interest, not to compensate him for the exact value of the chips. He also sought punitive damages and the jury found, by clear and convincing evidence, that "Hollywood casino should pay punitive damages for the plaintiff's § 1983 claim and his state-law claims for false imprisonment, malicious prosecution, abuse of process, conversion, and trespass to chattels in a total amount of \$600,500.00." This amount was also upheld on appeal. *Grosch v. Tunica Cty.*, Miss., 2009 WL 161856, at *1 (N.D. Miss. Jan. 22, 2009).

Note 3. Effect of Mistake. Note that mistaken beliefs regarding the chattel are not usually a defense. If in *Grosch* the casino had reasonably confused his chips with another player's, it would not alter the liability analysis unless the casino rectified its error immediately. Even a good-faith use of a chattel can satisfy the elements of both of the personal property torts if the belief is unreasonable in its mistake. When the mistake is reasonable—such as when a patron accidentally claims the wrong black suitcase at the airport baggage claim or the wrong generic-looking umbrella from a restaurant—whether liability attaches will depend on how quickly they discover and rectify the error.

Note 4. Trespass to chattels is a somewhat old-fashioned tort in that it is typically an action for damage to compensate for the costs of repairing or replacing property, which is often not worth bringing a lawsuit to redress. For some time, the use of trespass to chattels had fallen out of favor. However, in the internet era, trespass to chattels experienced a revival when the tort was mobilized to address unwanted commercial email such as spam, unwanted faxes, and "spiders" or automatic programs that search the internet and were held to be trespassing various database servers. Laura Quilter, *The Continuing Expansion of Cyberspace Trespass to Chattels*, 17 Berkeley Tech. L.J. 421 (2002). For example, in *eBay, Inc. v. Bidder's Edge, Inc.*, 100 F. Supp. 2d 1058 (N.D. Cal. 2000), the online auction site was held to be likely to prevail, for purposes of obtaining a preliminary injunction, against an online auction aggregating site which was conducting automated searches of the plaintiff's site without permission given evidence that the defendant's searches diminished the value of the plaintiff's site. The court explained its reasoning thus:

[T]he electronic signals generated by the [defendants'] activities were sufficiently tangible to support a trespass cause of action." [***] In order to prevail on a claim for trespass based on accessing a computer system, the plaintiff must establish: (1) defendant intentionally and without authorization *1070 interfered with plaintiff's

possessory interest in the computer system; and (2) defendant's unauthorized use proximately resulted in damage to plaintiff. *Id.* at 1069-70.

The use of trespass to chattels to address this new source of harm (and annoyance) reflects one of the ways in which tort law adapts to changing social, technological and economic circumstances.

**Luis v. Smith Partners & Associates Ltd., U.S. Dist Ct., N.D. Illinois, Eastern Division (2012)
(2012 WL 5077726)**

*1 Plaintiffs Maria Luis and Lucy Gomez brought this lawsuit against Defendants Smith Partners & Associates, Ltd., Smith REO Properties, Coya Smith, and Andy Horn, alleging violations of Title VIII of the Civil Rights Act of 1968, as amended by the Fair Housing Amendments Act of 1988 ("Fair Housing Act"), 42 U.S.C. § 3601 *et seq.*, [***] and Illinois law. Doc. 1. Defendants have moved to dismiss all claims under Federal Rule of Civil Procedure 12(b)(6). The motion is granted in part and denied in part. [***]

Plaintiffs reside at 5818 North Spaulding in Chicago, Illinois ("Property"). Doc. 1 at ¶ 5. [Editor's note: All remaining references to the record omitted] Smith Partners and Associates, Ltd., which operates under the assumed name Smith REO Properties, is a corporation that owns and manages residential properties. Smith Partners managed the Property throughout the relevant time period. Smith owns and operates Smith Partners. Horn is an agent of Smith Partners.

Beginning in Winter 2010, Defendants undertook a campaign of threats and harassment intended to force Plaintiffs to leave the Property. Defendants targeted Plaintiffs because they are Hispanic and in the belief that Hispanics are unwilling to defend themselves through the legal system. Horn entered the Property's basement at some point in Winter 2010 and removed the furnace, causing the pipes to freeze. In November 2010, Horn padlocked the front door, which prevented Plaintiffs from entering the residence. In Spring 2011, Horn banged on the windows and doors and removed letters from the mailbox that were addressed to Plaintiffs. In May 2011, Horn entered the basement and removed most of its contents, including the furnace that Plaintiffs bought to replace the one that Horn had removed. In August 2011, Horn had the electricity and water disconnected; while doing so, Horn entered the Property and struck Gomez with the intent of intimidating Plaintiffs into vacating the property. In March 2012, Horn broke the locks to the front doors of each apartment at the Property. Horn did all of this at the request of Smith, his boss. On April 17, 2012, the City of Chicago turned off the water due to non-payment by Defendants.

I. Fair Housing Act (Count I)

*2 The Fair Housing Act prohibits discrimination against "any person in the terms, conditions, or privileges of sale or rental of a dwelling, or in the provision of services or facilities in connection therewith, because of race, color, religion, sex, familial status, or national origin." 42 U.S.C. § 3604(b). The Act also makes it unlawful to "coerce, intimidate, threaten, or interfere with any person in the exercise or enjoyment of, or on account of his having exercised or enjoyed, or on account of his having aided or encouraged any other person in the exercise or enjoyment of, any right granted or protected

by section 3603, 3604, 3605, or 3606 of this title.” 42 U.S.C. § 3617. The Act governs conduct regardless of whether it occurs before or after a tenant or owner has acquired a property interest in a dwelling. [c]

To survive a motion to dismiss, a Fair Housing Act claim must allege discrimination related to the terms, conditions, privileges, or provisions of services of a dwelling. [cc] A claim also must plead the type of discrimination that occurred, by whom, and when. [cc] Here, Plaintiffs allege the type of discrimination that occurred (race or national origin), by whom (Smith, Horn, and Smith Partners), and when (from Winter 2010 through April 2012). These allegations are sufficient to survive a Rule 12(b)(6) motion. [cc] [***] [Editor’s note: Count II, a RICO claim, is omitted]

III. State Law Claims

A. Trespass to Chattel/Conversion (Count III)

Although the complaint labels Count III “Trespass to Chattel,” Plaintiffs’ brief recharacterizes the claim as one for conversion. Count III survives regardless of whether it is viewed as a trespass to chattel claim or a conversion claim. Under Illinois law, trespass to chattel is “injury to or interference with possession, with or without physical force ... to personal property.” [c] “A trespass to a chattel may be committed by intentionally (a) dispossessing another of the chattel, or (b) using or intermeddling with a chattel in the possession of another.” *Ibid.* (quoting Restatement (Second) of Torts § 217 (1965)). The complaint alleges that Defendants stole Plaintiffs’ furnace, depriving them of its use. The complaint also alleges that Defendants locked the basement so that Plaintiffs could not access it or its contents. This is sufficient to state a trespass to chattel claim. *See Matthews v. Homecoming Fin. Network*, 2005 WL 2387688, at *8 (N.D.Ill. Sept.26, 2005) (allegation that the “defendants forcibly entered [plaintiff’s] home without his consent and changed the locks” are sufficient to state a trespass to chattel claim).

“Any unauthorized act by which an owner is deprived of his property permanently or indefinitely, or the exercise of dominion over property inconsistent with the rights of the owner, [is] a conversion.” [***] Because Plaintiffs allege a permanent deprivation of property in their possession caused by Defendants’ unauthorized acts, they have pleaded a plausible conversion claim.

B. Battery (Count IV)

To state a battery claim under Illinois law, a plaintiff must allege that the defendant engaged in “the wilful touching of the person of another” and “intend [ed] to cause a harmful or offensive contact.” [cc] The complaint alleges that “Horn entered the property illegally, threatened Plaintiffs, and struck Plaintiff Lucy Gomez,” and that “[t]he battery against Lucy Gomez was intended, through actual physical force, to intimidate Plaintiffs into vacating the property.” These allegations are sufficient to state a battery claim. [***]

*7 Defendants submit that the battery claim cannot proceed against Smith Partners and Smith because the complaint does not allege that they intended for Horn to commit a battery and because respondeat superior liability does not attach in these circumstances. The complaint, however, alleges that Horn was acting within the scope of his agency at all relevant times and that he acted at Smith’s request. Under settled tort principles, “the employer’s vicarious liability extends to the negligent, willful,

malicious, or even criminal acts of its employees when such acts are committed within the scope of the employment.” [cc] It follows that the battery claim stands as to Smith Partners and Smith.

C. Intentional Infliction of Emotional Distress (Count V)

To state an intentional infliction of emotional distress claim under Illinois law, a plaintiff must allege that: (1) the defendant’s conduct was extreme and outrageous; (2) the defendant either intended to inflict severe emotional distress or knew that there was a high probability that his conduct would do so; and (3) the defendant’s conduct actually caused severe emotional distress. [cc] [***]

Here, Plaintiffs allege that Defendants took advantage of their role as property managers to perpetrate a pattern of harassing and intimidating conduct, including conduct as extreme as removing Plaintiffs’ furnace during a Chicago winter. The sole alleged purpose of these alleged actions was to drive Plaintiffs from the Property, and Plaintiffs suffered emotional distress as a result. “An important factor” in intentional infliction of emotional distress claims “is whether a defendant abused a position of authority.” [c] Plaintiffs have alleged sufficient facts to state a plausible emotional distress claim.

D. Chicago Residential Landlord and Tenant Ordinance (Count VI)

*8 The Chicago Residential Landlord and Tenant Ordinance (“RLTO”) provides in relevant part as follows:

It is unlawful for any landlord or any person acting at his direction knowingly to oust or dispossess or threaten or attempt to oust or dispossess any tenant from a dwelling unit without authority of law, by plugging, changing, adding or removing any lock or latching device; or by blocking any entrance into said unit; or by removing any door or window from said unit; or by interfering with the services to said unit; including but not limited to electricity, gas, hot or cold water, plumbing, heat or telephone service; or by removing a tenant’s personal property from said unit; or by the removal or incapacitating of appliances or fixtures, except for the purpose of making necessary repairs; or by the use or threat of force, violence or injury to a tenant’s person or property; or by any act rendering a dwelling unit or any part thereof or any personal property located therein inaccessible or uninhabitable.

Chicago, Ill., Municipal Code § 5–12–160. The complaint alleges that Defendants sought to oust Plaintiffs by removing their furnace, padlocking the Property’s front door, turning off their hot water heater, and breaking their locks. Such acts violate § 5–12–160 of the RLTO, so the viability of Count VI turns on whether the relationship between Plaintiffs and Defendants is governed by the ordinance.

Defendants argue that by not alleging the existence of a valid lease agreement, the complaint fails to adequately plead that Plaintiffs are “tenants.” The argument does not carry the day. Although the complaint does not expressly allege that Plaintiffs are “tenants,” it alleges that they are “residents” and refers to the existence of a “tenancy” during the relevant period. This is sufficient at this point to plead that Plaintiffs are tenants. [***]

E. Statute of Limitations

The battery and intentional infliction of emotional distress claims are governed by a two-year statute of limitations. *See* 735 ILCS 5/13–202 (2008); [cc] So, too, is the RLTO claim. *See Landis v. Marc*

Realty, LLC, 235 Ill.2d 1, 335 Ill.Dec. 581, 919 N.E.2d 300 (Ill.2009). Defendants contend that portions of these claims are barred on limitations grounds. As noted above, however, the instances of alleged misconduct all occurred within two years of the complaint's filing. Defendants' contention accordingly has no merit. [***]

Defendants also contend that Smith is not liable for any torts committed by Smith Partners or Horn. As noted above, the complaint alleges that Horn undertook his tortious actions at Smith's request and as an agent of Smith Partners. "It is well established that traditional vicarious liability rules ordinarily make principals or employers vicariously liable for acts of their agents or employees in the scope of their authority or employment." [cc] This is true "even if the principal neither authorized nor ratified the acts." [c] It follows, at least at the pleading stage, that Smith is a proper defendant.

*10 [The court denied the motion to dismiss as to Counts I, III, IV, V and VI].

Note 1. Given the ample evidence of multiple kinds of tortious conduct in this case, does it surprise you that the defendants fought it rather than settling? What was behind their litigation strategy, do you think?

Note 2. Tort law is available to remedy numerous harms the plaintiffs suffered on these facts. But should tort law be the appropriate remedy in a case like this one? Why or why not? Should tort law be necessary if the Fair Housing Act and municipal laws already proscribe the kinds of acts in which the defendant engaged? What does tort law add? What are the costs of using tort law to remedy these wrongs?

U.S. v. Hatahley, U.S. Court of Appeals Tenth Circuit (1958) (257 F.2d 920)

This case is before us for the second time. It was brought by the plaintiffs, who are Indians of the Navajo tribe, under the provisions of the Federal Tort Claims Act (28 U.S.C.A. §§ 1346(b) and 2671 et seq.), to recover \$100,000 as damages for the loss of horses and burros which they allege were wrongfully and unlawfully seized and destroyed in the State of Utah by agents of the United States Bureau of Land Management. The trial court found for the plaintiffs and entered a lump sum judgment of \$100,000. We reversed on the grounds that the horses and burros in question had been lawfully seized and disposed of under the Utah 'abandoned horse' statute. *922 Utah Code Ann.1953, Title 47, Chapter 2. We did not consider the question of liability under the Federal Tort Claims Act, or the sufficiency of the findings as to damages. *United States v. Hatahley*, 10 Cir., 220 F.2d 666. The United States Supreme Court reversed, and held that the provisions of the Federal Range Code must be complied with before local procedures may be resorted to for the removal of trespassing livestock from the public range. It was also held that the acts of the government agents 'were wrongful trespasses not involving discretion', which gave rise to a claim compensable under the Federal Tort Claims Act. The case was remanded for specific findings as to damages. *Hatahley v. United States*, 351 U.S. 173, 76

S.Ct. 745, 752, 100 L.Ed. 1065.⁶⁴ The factual background is set forth in our former opinion and that of the Supreme Court, and need not be repeated here.

Upon remand, the District Court took additional evidence on the issue of consequential damages, and without an amendment of the complaint, entered a judgment against the United States for the total sum of \$186,017.50. The value of each horse or burro taken was fixed at \$395; each plaintiff was awarded \$3,500 for mental pain and suffering; and damages were given for one-half of the value of the diminution of the individual herds of sheep, goats and cattle between the date the horses and burros were taken in 1952, and the date of the last hearing in 1957. Except as to those relating to specific damages for each plaintiff, the findings of fact are generally a resume of the evidence favorable to the plaintiffs, and inferences which the court thought could be reasonably drawn therefrom. The United States contends that there were numerous errors in rejecting evidence, limiting cross-examination, and in disregarding fundamental principles of law. It vigorously insists that there has not been a fair and impartial trial as to damages, and that one cannot be obtained except before another Judge.

The parties stipulated as to the number of horses and burros which were taken from each plaintiff in the range clearance program. The damage for this wrongful taking is to be determined by the law of Utah. In *Egelhoff v. Ogden City*, 71 Utah 511, the Supreme Court of Utah, in discussing the rule as to damages in a case of this kind, said:

‘* * * Appellant contends that the measure of damages in this case is the difference between the market value of the property immediately before and immediately after the injury. It may be conceded that such is the proper measure of damages. It has been held by this court that the measure of damages for the destruction of a house is the ‘cost to reproduce it, and the value of its *923 use while that was being done.’ [c].⁶⁵

Cf. *Angerman Co., Inc., v. Edgermon*, 76 Utah 394. (Personal property not entirely destroyed). In a recent case the Utah court applied the replacement rule where personal property (poultry) was destroyed. [cc]

The fundamental principle of damages is to restore the injured party, as nearly as possible, to the position he would have been in had it not been for the wrong of the other party. [cc]⁶⁶ Applying this

⁶⁴ In referring to damages, the Supreme Court said: ‘The District Court awarded damages in the lump sum of \$100,000, the amount sought by petitioners jointly. Apparently this award was based on the value of the horses, consequential damages for deprivation for use and for ‘mental pain and suffering.’ Under the Federal Tort Claims Act, damages are determined by the law of the State where the tortious act was committed, 28 U.S.C. § 1346(b), 28 U.S.C.A. § 1346(b), subject to the limitations that the United States shall not be liable for ‘interest prior to judgment or for punitive damages.’ 28 U.S.C. § 2674, 28 U.S.C.A. § 2674. But it is necessary in any case that the findings of damages be made with sufficient particularity so that they may be reviewed. Here the District Court merely awarded the amount prayed for in the complaint. There was no attempt to allot any particular sum to any of the 30 plaintiffs, who owned varying numbers of horses and burros. There can be no apportionment of the award among the petitioners unless it be assumed that the horses were valued equally, the burros equally, and some assumption is made as to the consequential damages and pain and suffering of each petitioner. These assumptions cannot be made in the absence of pertinent findings, and the findings here are totally inadequate for review. The case must be remanded to the District Court for the appropriate findings in this regard.’ 351 U.S. 182.

⁶⁵ As a general rule, market value is the highest price a purchaser is willing to pay for property, not being under compulsion to buy, and the lowest price a seller is willing to accept, not being under compulsion to sell. [cc]

⁶⁶ Restatement of the Law of Torts, Section 912, states the rule as follows: ‘A person to whom another has tortiously caused harm is entitled to compensatory damages therefor if, but only if, he established by proof the extent of such

rule, the plaintiffs were entitled to the market value, or replacement cost, of their horses and burros as of the time of taking, plus the use value of the animals during the interim between the taking and the time they, acting prudently, could have replaced the animals.

The plaintiffs did not prove the replacement cost of the animals, but relied upon a theory that the animals taken were unique because of their peculiar nature and training, and could not be replaced. The trial court accepted this theory, and relying upon some testimony that a horse or a burro could be traded among Indians for sheep, goats or cattle worth a stated price, together with the owner's testimony of the value, arrived at a market value of \$395 per head. No consideration was given to replacement cost. The court rejected evidence of the availability of like animals in the immediate vicinity, and their value. This, we think, was error.

It is true that animals of a particular strain and trained for a special purpose are different from animals of another strain and not so trained, but that does not mean that they cannot be replaced by animals similarly developed and trained, or which may be trained after acquisition. Ordinarily every domestic animal is developed and trained for the purpose to which the owner intends to use it. This development and training adds to its usefulness and generally increases the market value of the animal. In arriving at a fair market value of destroyed animals, the court should considered evidence of the availability of like animals, together with all other elements which go to make up market value. In proper instances, parties and witnesses may be cross-examined on the subject.

Likewise, we think the court applied an erroneous rule, wholly unsupported by the evidence, in arriving at the amount of loss of use damage. There was testimony by the plaintiffs that because of the loss of their horses and burros they were not able to maintain and look after as much livestock as they had been able to before the unlawful taking, consequently the size of their herds was reduced. If the unlawful taking of the animals was the proximate cause of the herd reductions, the measure of damages would be the loss of profits occasioned thereby. [c]

***924** Applying the same formula to all plaintiffs, the court, without giving consideration to the condition, age or sex of the animals, found the value of the sheep and goats in 1952 to be \$15 per head, the cattle to be \$150 per head. The number of sheep, goats and cattle which each plaintiff had in 1952, as well as the number which each had at the date of the last hearing was established. This difference was multiplied by \$15, in the case of sheep and goats, and by \$150, in the case of cattle, and judgment was entered for one-half of the amount of the result. No consideration was given to the disposition of the livestock by the plaintiffs in reducing the herds. For example, the plaintiff Sakezzie had 600 sheep and goats and 101 head of cattle when his horses and burros were taken in 1952. At the date of the last hearing in 1957, he had 160 head of sheep and goats and 39 head of cattle. The dollar value of the difference at \$15 per head for the sheep and goats, and \$150 per head for the cattle, amounted to \$15,900. The court found 'that approximately fifty percent of this amount represents damages to the plaintiff proximately caused by deprivation of the use of plaintiff's horses, and on this basis plaintiff is entitled to recover \$7,950.00 as consequential damages resulting from such deprivation'. The result, insofar as it related to use damage, was arbitrary, pure speculation, and clearly erroneous. In *United States v. Huff*, 5 Cir., 175 F.2d 678, a case where the method of computing damages for loss of sheep and goats was strikingly similar to that used here, the court said:

harm and the amount of money representing adequate compensation with such certainty as the nature of the tort and the circumstances permit.'

‘Moreover, there has been no sufficient showing of how much of the damage from the loss of the sheep and goats was proximately caused by the Government’s failure to maintain and repair the fences under the lease, and how much of the damage resulted from the various other causes. There is no testimony whatever as to the specific dates of loss of any of the sheep and goats, or as to their age, weight, condition and fair market value at the time of the alleged losses. It therefore becomes patent that the evidence as to the loss of these animals in each case fails to rise above mere speculation and guess.’ 175 F.2d 680.⁶⁷

Plaintiffs’ evidence indicated that the loss of their animals made it difficult and burdensome for them to obtain and transport needed water, wood, food, and game, and curtailed their travel for medical care and to tribal council meetings and ceremonies. Plaintiffs also testified that because of the loss of their animals they were not able to grow crops and gardens as extensively as before. These were factors upon which damages for loss of use could have been based. This does not exclude the right to damages for loss of profits which may have resulted from reduction of the number of livestock, or actual loss of the animals, if the unlawful acts of the defendant agents were the proximate cause of the loss and were proved to a reasonable degree of certainty. [cc] But the right to such damages does not extend forever, and it is limited to the time in which a prudent person would replace the destroyed horses and burros. The law requires only that the United States make full reparation for the pecuniary loss which their agents inflicted.

The District Court awarded each plaintiff the sum of \$3,500 for mental pain and suffering. There is no evidence that any plaintiff was physically injured *925 when his horses and burros were taken. There was evidence that because of the seizure of their animals and the continued activity of government agents and white ranchers to rid the public range of trespassers, the plaintiffs and their families were frightened, and after the animals were taken, they were ‘sick at heart, their dignity suffered, and some of them cried’. There was considerable evidence that some of the plaintiffs mourned the loss of their animals for a long period of time. We think it quite clear that the sum given each plaintiff was wholly conjectural and picked out of thin air. The District Court seemed to think that because the horses and burros played such an important part in the Indians’ lives, the grief and hardships were the same as to each. The equal award to each plaintiff was based upon the grounds that it was not possible to separately evaluate the mental pain and suffering as to each individual, and that it was a community loss and a community sorrow.⁶⁸

Apparently the court found a total amount which should be awarded to all plaintiffs for pain and suffering, and divided it equally among them. There was no more justification for such division than there would have been in using the total value of the seized animals and dividing it equally among the

⁶⁷ In *Graham v. Street*, 2 Utah 2d 144, 270 P.2d 456, the Supreme Court of Utah said: ‘The rule is stated in 4 *Sutherland, Damages*, 4th Ed., Sec. 1175, as follows: ‘Only such damages are recoverable as are shown with reasonable certainty to have been sustained. Remote, contingent and conjectural losses will not be considered.’ [c]

⁶⁸ The court’s finding on this subject is as follows: ‘28. It is not possible for the extent of the mental pain and suffering to be separately evaluated as to each individual plaintiff. It is evident that each and all of the plaintiffs sustained mental pain and suffering. Nor is it possible to say that the plaintiffs who lost one or two horses sustained less mental pain and suffering than plaintiffs who lost a dozen horses. The mental pain and suffering sustained was a thing common to all the plaintiffs. It was a community loss and a community sorrow shared by all. On this basis, the Court finds and awards the sum of \$3,500.00 to each of the plaintiffs as a fair and reasonable approximation of the mental pain and suffering sustained by each, as a proximate result of the taking of the horses by the defendant.’

plaintiffs. Pain and suffering is a personal and individual matter, not a common injury, and must be so treated. While damages for mental pain and suffering, where there has been no physical injury, are allowed only in extreme cases, they may be awarded in some circumstances. Restatement of the Law of Torts, §§ 46, 47; [cc] Any award for mental pain and suffering in this case must result from the wrongful taking of plaintiffs' animals by agents of the United States, and nothing else.

As the case must be remanded for a new trial as to damages, we are confronted with the contention of the United States that it cannot obtain a fair and impartial trial before the same Judge because of his personal feelings in the matter. In our former opinion we had occasion to make some observations concerning the conduct of the trial. The Supreme Court referred to these observations on the bias and prejudice of the presiding Judge, and said that the trial was not so improperly conducted as to vitiate the findings. This statement did not relate to any of the findings as to damages which are under consideration here. A casual reading of the two records leaves no room for doubt that the District Judge was incensed and embittered, perhaps understandably so, by the general treatment over a period of years of the plaintiffs and other Indians in southeastern Utah by the government agents and white ranchers in their attempt to force the Indians onto established reservations.

This was climaxed by the range clearance program, with instances of brutal handling and slaughter of their livestock, which the Court, during trial, referred to as 'horrible', 'monstrous', 'atrocious', 'cruel', 'coldblooded depredation', and 'without a sense of decency'. The Court firmly believed that the Indians were being wrongfully *926 driven from their ancestral homes, and suggested Presidential and Congressional investigations to determine their aboriginal rights. He threatened to conduct such an investigation himself. A public appeal on behalf of the plaintiffs was made for funds and supplies to be cleared through the Judge's chambers.⁶⁹ From his obvious interest in the case, illustrated by conduct and statements made throughout the trial, which need not be detailed further, we are certain that the feeling of the presiding Judge is such that, upon retrial, he cannot give the calm, impartial consideration which is necessary for a fair disposition of this unfortunate matter, and he should step aside.

Plaintiffs' claims are asserted under the Federal Tort Claims Act. In applying this Act, everyone should be treated the same. Racial differences merit no concern. Feelings of charity or ideological sympathy for the Indians must be put to one side. The deep concern which the executive and legislative branches of the government should have for the plaintiffs does not justify the court in giving them any better or worse treatment than would be given to anyone else. As Justice Jackson said in his concurring opinion in *Northwestern Bands of Shoshone Indians v. United States*, 324 U.S. 335, 355, 65 S.Ct. 690, 700, 89 L.Ed. 985: 'The Indian problem is essentially a sociological problem, not a legal one. We can make only a pretense of adjudication of such claims, and that only by indulging the most unrealistic and fictional assumptions.'

[***]

Reversed, and remanded for a new trial as to damages only.

⁶⁹ The allowance of \$395 per head for the Indian horses and burros, and \$3,500 for mental pain and suffering for their loss, is of itself an indication of the desire of the presiding Judge to assist the plaintiffs for the different wrongs which they had suffered.

Note 1. What did plaintiffs seek in terms of the value of their losses? How did the various adjudicators calculate the monetary amounts of the losses suffered? How did the theories of valuation differ, comparing the judges' and the plaintiffs' views?

Note 2. What does the court appear to be concerned about when it writes: "Any award for mental pain and suffering in this case must result from the wrongful taking of plaintiffs' animals by agents of the United States, and nothing else"? What does it suggest was improper or erroneous about the awards made to the plaintiffs?

Note 3. This dispute took over a decade to resolve and is reported to have been the first time Native Americans successfully sued the U.S. government for intentional wrongdoing. Yet in its bitter-fought victory, there were many reversals and losses. The original District Judge, William Ritter, was deemed too sympathetic to the Indian cause and formally ousted over his own objections. The opinion you read describes Ritter, in a manner that is internally contradictory, or at a minimum, ambivalent. On the one hand, Ritter was "incensed and embittered," but on the other hand the treatment of Native Americans was, in the court's own words, replete with "brutal handling and slaughter of their livestock." The court takes Ritter to task for the use of emotional language ("horrible", 'monstrous', 'atrocious', 'cruel', 'coldblooded depredation', and 'without a sense of decency') and suggests that he may be incapable of being "impartial" because of his belief that "Indians were being wrongfully driven from their ancestral homes."

Considered through a contemporary lens, the opposite appears true. Indeed, Ritter fought to try to remain on the case:

The Tenth Circuit also suggested that the case be assigned to a new judge because the original judge was biased in favor of the Navajos. Judge Ritter ignored this suggestion. His answer to the government's application for a special master to determine damages was that he did not intend to follow the Tenth Circuit's suggestion that he step down, "so you can lay that to one side." The government then applied to the Tenth Circuit for the entry of a judgment on the mandate prohibiting Ritter from retrying the case a third time. The Tenth Circuit ordered that Ritter "take no further action" in the case. Because at that time the U.S. District Court for the District of Utah had only a single sitting judge (Ritter), the Chief Judge for the Tenth Circuit, Alfred P. Murrah, assigned the case to Judge Ewing T. Kerr, U.S. District Judge for the District of Wyoming. A little over a year later, the case settled. The Navajo plaintiffs received \$45,000 before deduction of attorneys fees, less than half the amount awarded them at the first trial (\$100,000) and less than a quarter of what they had been awarded at the second trial (\$186,017.50). Debora L. Threedy, *United States v. Hatahley: A Legal Archaeology Case Study in Law and Racial Conflict*, 34 Am. Indian. L. Rev. 1, 7-8 (2009) (internal citations omitted).

The opinion is clear in its unstinting critique of Ritter. It is thus striking to see the opinion wrestling with the issue of the court's positionality itself. In the final paragraph of the opinion, the court writes somewhat harshly that "[r]acial differences merit no concern". The phrase seems intended to evoke neutrality by flattening racial differences. Yet its characterization of support for the Native American position is hardly neutral; the court minimizes critique of mass territorial dispossession as "[f]eelings

of charity or ideological sympathy for the Indians.” In so doing, it frames the issue in a way that effaces the United States’ role in disrupting the sociopolitical status of Native Americans.

What exactly is the nature of the court’s arguments, as it refers to “the deep concern” that “should” exist in other branches of the government but that “does not justify” its own particular action? What is intended by the phrase “[t]he Indian problem is essentially a sociological problem, not a legal one”? Note that the premise that there is an “Indian problem” disclaims judicial responsibility for creating or maintaining the “problem,” and it reinforces the existing legal hierarchy. Describing it in this way situates the problem as somehow belonging to the population the U.S. government seeks to control; it becomes a problem “about” the Native Americans instead of being acknowledged as a problem produced by violence and dominion and the mobilization of vastly disparate power and resources to entrench the status quo.

Does the court have authority, descriptively, to do more than it seems to acknowledge? Normatively, should it? What questions would you need answered to think further about these issues? Is there a point to rhetoric that acknowledges judicial powerlessness, in cases where judges truly believe they cannot act as they may wish they could?

Chapter 13. Defenses Against the Intentional Torts

The most common defenses against the intentional torts are **consent** and **self-defense**. Additional defenses, **defense of others** and **defense of property** are also sometimes available, as are the defenses of public and private necessity. Consent is a defense for the defendant to plead but it may also be an element for the plaintiff to overcome in pleading if the facts tend to suggest that a plaintiff gave consent to physical contact (which would defeat battery) or to entry onto land (which would defeat trespass). If a person consents to something and the contact or entry on land exceeds the scope of the consent, liability may arise. Often the difficult questions concern the scope of consent given and whether it was given at all. Assuming consent was manifested, its validity will be the final issue to consider. Any consent given through fraud, mistake, duress or incapacity will cause the consent to be invalid.

Consent

O'Brien v. Cunard S.S. Co., Ltd, Supreme Judicial Court of Massachusetts (1891) (154 Mass. 272)

This case presents two questions: First, whether there was any evidence to warrant the jury in finding that the defendant, by any of its servants or agents, committed ~~an assault~~ [a battery]⁷⁰ on the plaintiff; secondly, whether there was evidence on which the jury could have found that the defendant was guilty of negligence towards the plaintiff. To sustain the first count, which was for an alleged assault, the plaintiff relied on the fact that the surgeon who was employed by the defendant vaccinated her on ship-board, while she was on her passage from Queenstown to Boston.

On this branch of the case the question is whether there was any evidence that the surgeon used force upon the plaintiff against her will. In determining whether the act was lawful or unlawful, the surgeon's conduct must be considered in connection with the surrounding circumstances. If the plaintiff's behavior was such as to indicate consent on her part, he was justified in his act, whatever her unexpressed feelings may have been. In determining whether she consented, he could be guided only by her overt acts and the manifestations of her feelings. *Ford v. Ford*, 143 Mass. 578; *McCarthy v. Railroad Corp.*, 148 Mass. 550, 552.

It is undisputed that at Boston there are strict quarantine regulations in regard to the examination of emigrants, to see that they are protected from small-pox by vaccination, and that only those *274 persons who hold a certificate from the medical officer of the steam-ship, stating that they are so protected, are permitted to land without detention in quarantine, or vaccination by the port physician. It appears that the defendant is accustomed to have its surgeons vaccinate all emigrants who desire it, and who are not protected by previous vaccination, and give them a certificate which is

⁷⁰ Editor's note: Confusingly, the court here makes an older use of the term "assault" to describe the action of battery as we now understand it. The strike-through and the addition of "a battery" are edits to clarify the case; continue to substitute "battery" where the case refers to "assault."

accepted at quarantine as evidence of their protection. Notices of the regulations at quarantine, and of the willingness of the ship's medical officer to vaccinate such as needed vaccination, were posted about the ship in various languages, and on the day when the operation was performed the surgeon had a right to presume that she and the other women who were vaccinated understood the importance and purpose of vaccination for those who bore no marks to show that they were protected.

By the plaintiff's testimony, which, in this particular, is undisputed, it appears that about 200 women passengers were assembled below, and she understood from conversation with them that they were to be vaccinated; that she stood about 15 feet from the surgeon, and saw them form in a line, and pass in turn before him; that he "examined their arms, and, passing some of them by, proceeded to vaccinate those that had no mark;" that she did not hear him say anything to any of them; that upon being passed by they each received a card, and went on deck; that when her turn came she showed him her arm; he looked at it, and said there was no mark, and that she should be vaccinated; that she told him she had been vaccinated before, and it left no mark; "that he then said nothing; that he should vaccinate her again;" that she held up her arm to be vaccinated; that no one touched her; that she did not tell him she did not want to be vaccinated; and that she took the ticket which he gave her, certifying that he had vaccinated her, and used it at quarantine. She was one of a large number of women who were vaccinated on that occasion, without, so far as appears, a word of objection from any of them. They all indicated by their conduct that they desired to avail themselves of the provisions made for their benefit. There was nothing in the conduct of the plaintiff to indicate to the surgeon that she did not wish to obtain a card which would save her from detention at quarantine, and to be vaccinated, if necessary, for that *275 purpose. Viewing his conduct in the light of the surrounding circumstances, it was lawful; and there was no evidence tending to show that it was not. The ruling of the court on this part of the case was correct.

The plaintiff contends that, if it was lawful for the surgeon to vaccinate her, the vaccination was negligently performed. "There was no evidence of want of care or precaution by the defendant in the selection of the surgeon, or in the procuring of the virus or vaccine matter." Unless there was evidence that the surgeon was negligent in performing the operation, and unless the defendant is liable for this negligence, the plaintiff must fail on the second count.

Whether there was any evidence of negligence of the surgeon we need not inquire, for we are of opinion that the defendant is not liable for his want of care in performing surgical operations. The only ground on which it is argued that the defendant is liable for his negligence is that he is a servant engaged in the defendant's business, and subject to its control. We think this argument is founded on a mistaken construction of the duty imposed on the defendant by law. By the fifth section of the act of congress of August 2, 1882, (22 U.S.St. at Large, 188,) it is provided that "every steam-ship or other vessel carrying or bringing emigrant passengers, or passengers other than cabin passengers, exceeding fifty in number, shall carry a duly competent and qualified surgeon or medical practitioner, who shall be rated as such in the ship's articles, and who shall be provided with surgical instruments, medical comforts, and medicines proper and necessary for diseases and accidents incident to sea voyages, and for the proper medical treatment of such passengers during the voyage, and with such articles of food and nourishment as may be proper and necessary for preserving the health of infants and young children; and the services of such surgeon or medical practitioner shall be promptly given in any case of sickness or disease to any of the passengers or to any infant or young child of any such passengers,

who may need his services. For a violation of either of the provisions of this section the master of the vessel shall be liable to a penalty not exceeding two hundred and fifty dollars.”

Under this statute it is the duty of the ship-owners to provide a competent surgeon, whom the passengers may employ, if they *276 choose, in the business of healing their wounds, and curing their diseases. The law does not put the business of treating sick passengers into the charge of common carriers, and make them responsible for the proper management of it. The work which the physician or surgeon does in such cases is under the control of the passengers themselves. It is their business, not the business of the carrier. They may employ the ship’s surgeon, or some other physician or surgeon who happens to be on board, or they may treat themselves if they are sick, or may go without treatment if they prefer; and, if they employ the surgeon, they may determine how far they will submit themselves to his directions, and what of his medicines they will take and what reject, and whether they will submit to a surgical operation or take the risk of going without it. The master or owners of the ship cannot interfere in the treatment of the medical officer when he attends a passenger. He is not their servant, engaged in their business, and subject to their control as to his mode of treatment. They do their whole duty if they employ a duly qualified and competent surgeon and medical practitioner, and supply him with all necessary and proper instruments, medicines, and medical comforts, and have him in readiness for such passengers as choose to employ him.

This is the whole requirement of the statute of the United States applicable to such cases; and if, by the nature of their undertaking to transport passengers by sea, they are under a liability at the common law to make provision for their passengers in this respect, that liability is no greater. It is quite reasonable that the owners of a steam-ship used in the transportation of passengers should be required by law to provide a competent person to whom sick passengers can apply for medical treatment, and when they have supplied such a person it would be unreasonable to hold them responsible for all the particulars of his treatment when he is engaged in the business of other persons, in regard to which they are powerless to interfere. The reasons on which it is held in the courts of the United States and of Massachusetts that the owners are liable for the negligence of a pilot in navigating the ship, even though he is appointed by public agencies, and the master has no voice in the selection of him, do not apply to this case. *The China*, 7 Wall. 53-67; *Yates v. Brown*, 8 Pick. 23. The pilot is engaged *277 in the navigation of the ship, for which, on grounds of public policy, the owners should be held responsible. The business is theirs, and they have certain rights of control in regard to it. They may determine when and how it shall be undertaken, and the master may displace the pilot for certain causes. But in England it has been held that even in such case the owners are not liable. [cc] The view which we have taken of this branch of the case is fully sustained by a unanimous judgment of the court of appeals of New York in *Laubheim v. De Koninglyke N.S. Co.*, 107 N.Y. 228, 13 N.E.Rep. 781. [cc] We are of opinion that on both parts of the case the rulings at the trial were correct. The evidence excepted to was rightly admitted. Exceptions overruled.

Note 1. Manifestations of consent can be verbal, in writing, or made orally. But as this case shows, they may also be made through physical actions. Can you think of instances—like the facts reported in this case—in which one’s actions and words may be at odds?

Note 2. Considering the range of choices Ms. O’Brien faced—remain on the ship and sail home or disembark only after being vaccinated—does her consent seem freely given or under pressures that tort law should acknowledge? Why did O’Brien initially attempt to refuse vaccination? Why do you think she sued? Was her societal status relevant in her experience on the ship?

Multiple scholars who have delved into the trial record have offered a more thorough account of Ms. O'Brien's actions. Read the two accounts below. They are somewhat similar even if they have some differences. If these accounts are accurate, does your view of the ruling change?

From the trial record we learn that Mary O'Brien was a seventeen year-old Irish emigrant traveling with her father and younger brother to Boston in steerage, the cheapest possible accommodations on a passenger ship. Ms. O'Brien was poor, unsophisticated, and not very educated (she did not understand the meaning of the terms "quarantine" and "vaccinate" when she read them on the signs posted around the ship). The steerage steward told the 200 Irish women steerage passengers who were on deck that they had to go below into steerage, without telling them why. (At another point, the male Irish steerage passengers were told to go down into steerage and were "hosed down before they knew what was to be done.") There was only one way out of the steerage area, a door at the top of a staircase. At the middle of the staircase was a landing occupied by the doctor and two steerage stewards. There was no other exit. The women were lined up in such a way that they could not leave until they had been examined. One of the steerage stewards stood in front of the door leading to the deck so that no one could leave without the surgeon's order. Mary O'Brien, separated from her father for the first time, nervously avoided getting in line until all the other women had been examined by the doctor and passed through the door leading to the deck. She was left standing alone ...in a dim narrow passageway, surrounded by three insistent men clothed in authority. She told the doctor that she had been vaccinated before. He retorted that she "must" be vaccinated. (Although the court's opinion states that the doctor said that she "should" be vaccinated, Ms. O'Brien testified that he said she "must" be vaccinated.)

Jody Armour, *Just Deserts: Narrative, Perspective, Choice, and Blame*, 57 U. Pitt. L. Rev. 525, 532–33 (1996).

The steerage steward told the 200 women steerage passengers who were on deck that they had to go below into steerage, without telling them the reason. From the steerage area, there was only one door, which was at the top of a staircase. At the middle of the staircase was a landing where the doctor and two steerage stewards positioned themselves. There was no other way to leave steerage. The 200 women were lined up and told that they would not be allowed to leave until they had been examined. One of the steerage stewards stood at the door leading to the deck and let no one leave without the doctor's order. ... The women were lined up, and one by one, passed by the doctor. They were not asked if they wished to be examined. They were not told the purpose of the examination. Dr. Giffen examined each woman's arm to see if there was a vaccination mark. Those with a mark were allowed to pass. Those without were vaccinated. As they left, the doctor instructed the steward to give each a card. Once the threatening and coercive nature of the situation is acknowledged, the doctor's actions can be understood as part of the exercise of superior force to compel acquiescence. ... She did not get in line, but stood to the side. When she was the only one left, except the two stewards, she went up to the doctor and told him that she had been vaccinated before. He did not inquire about the previous vaccination. How did she know she had

received one? What did she know about it? On what part of her body was it administered? He did not examine her to see if there was a mark anyplace else on her body. He did not explain her choices if she had no mark. He did not discuss how a prior vaccination that left no mark would be treated by the public health authorities in Boston. He simply told her she had to be vaccinated.

Ann C. Shalleck, *Feminist Legal Theory and the Reading of O'Brien v. Cunard*, 57 Mo. L. Rev. 371-372, 383 (1992).

Shalleck concludes from this additional set of facts that “[i]t was reasonable for her to voice no further objection. It was not reasonable for the doctor to conclude that she had given freely her consent.” We might wonder why the court would withhold such facts given that they were present in the record; we might reasonably wonder why the case continues to be used as an example of manifesting consent, based on a set of facts that offer a distorted, inaccurate reality. In Shalleck’s view, the silencing of Ms. O’Brien is consistent with social patterns: “Women’s experiences of vulnerability and danger have been an important part of their subordination. The law has been slow to acknowledge the circumstances that create threats to women.” *Id.*

O'Brien v. Cunard offers an object lesson in law’s power to set certain narratives that become all but impossible to disrupt and reframe. On facts similar to those the court depicts, the rule of the case would still be “good law” and can be cited as such. This is true even though the coercive nature of the vaccination can be discerned in the court’s telling: as an immigrant seeking entry, O’Brien would need to comply with the regulations in place in the United States. She didn’t have all that much freedom to choose otherwise unless she wanted to choose to return to Ireland. Perhaps our recent pandemic makes it clear that there may be times when the governmental mandate to act overcomes individual autonomy to a certain extent in certain contexts. In light of the more accurate facts offered in the accounts above, however, the case reminds us of the power courts possess to fix one version of a story and fit it to the legal rules their opinions clarify and justify. That judicial authority can disempower and silence, or it can empower and bear witness. As readers of these cases, we can learn to read them on many levels.

Note 3. Revisit the purposes of tort law. Is vaccination a special kind of activity that requires different rules or protections, either to fulfill tort law’s purposes or for social, epidemiological or political reasons?

Note 4. Distinguish implied license from consent: recall the kicking classmate hypothetical, above, which was drawn from *Vosburg v. Putney*. *Vosburg* (not assigned) provided dicta emphasizing that the conduct was wrongful in part because of the context in which the kick occurred: in class, not recess. *Vosburg v. Putney*, 50 N.W. 403 (Wisc.1891).

Had the parties been upon the play-grounds of the school, engaged in the usual boyish sports, the defendant being free from malice, wantonness, or negligence, and intending no harm to plaintiff in what he did, we should hesitate to hold the act of the defendant unlawful, or that he could be held liable in this action. Some consideration is due to the implied license of the play-grounds. But it appears that the injury was inflicted in the school, after it had been called to order by the teacher, and after the regular exercises of the school had commenced. Under these circumstances, no implied license to do the act complained of existed, and such act was a violation of the order and decorum of the school, and necessarily unlawful.

Had this same kick taken place out on the playground, in the rough-and-tumble of recess, for instance, the outcome might have been different. Participation in playground games and other activities in which contact with others is likely may give rise to an implied license. If someone throws a ball at you after you've said, "I don't want to play," you clearly haven't agreed to participate, and throwing the ball at you might constitute a battery by the thrower. But if you agree to a game and begin to play it, you've agreed to at least some contact, within the expected bounds of the game. How should tort law define the outer limits of that contact? When are those limits exceeded? Anger or insolence made along with the contact? Cheating at the game? Are certain kinds of cheating worse than others, from the perspective of tort law's aims? Does it matter if the context is amateur versus professional?

Note 5. Restatement (Second) of Torts § 892 A. Effect of Consent; Comment

(1) One who effectively consents to conduct of another intended to invade his interests cannot recover in an action of tort for the conduct or for harm resulting from it.

(2) To be effective, consent must be

(a) by one who has the capacity to consent or by a person empowered to consent for him, and

(b) to the particular conduct, or to substantially the same conduct.

(3) Conditional consent or consent restricted as to time, area or in other respects is effective only within the limits of the condition or restriction.

(4) If the actor exceeds the consent, it is not effective for the excess.

(5) Upon termination of consent its effectiveness is terminated, except as it may have become irrevocable by contract or otherwise, or except as its terms may include, expressly or by implication, a privilege to continue to act.

(1) Consent is **willingness in fact for conduct to occur**. It may be **manifested by action or inaction** and need not be communicated to the actor.

(2) if words or conduct are reasonably understood by another to be intended as consent, they constitute "**apparent consent**" and are as effective as consent in fact.

Even when the person concerned does not in fact agree to the conduct of the other, his words or acts or even his inaction may manifest a consent that will justify the other in acting in reliance upon them. This is true when the words or acts or silence and inaction, would be understood by a reasonable person as intended to indicate consent and they are in fact so understood by the other. This conduct is not merely evidence that consent in fact exists, to be weighed against a denial. It is a manifestation of apparent consent, which justifies the other in acting on the assumption that consent is given and is as effective to prevent liability in tort as if there were consent in fact. On the other hand, if a reasonable person would not understand from the words or conduct that consent is given, the other is not justified in acting upon the assumption that consent is given even though he honestly so believes; and there is then no apparent consent.

Reading the Restatement (Second) of Torts § 892 A, above, can you identify the uses of both objective and subjective standards?

Check Your Understanding (2-6)

Question 1. Which of the following plaintiffs is most likely to meet the elements of **battery**?

An interactive H5P element has been excluded from this version of the text. You can view it online here: <https://saidtorts2d.lawbooks.cali.org/?p=50#h5p-44>

Hypothetical: Pro-Football / Miami Dolphins v. Denver Broncos: The incident that gave rise to this lawsuit occurred near the end of the first half of the football game between the Miami Dolphins and the Denver Broncos at a time when the Denver team was leading by a score of 21 to 3. John Haden was playing a free safety position on the Broncos' defensive team and Dan Park was playing fullback on the Dolphins' offensive team. The Miami team attempted a forward pass play during which Dan Park ran into a corner of the north end zone as a prospective receiver. That took him into an area which was the defensive responsibility of Mr. Haden. The thrown pass was intercepted near the goal line by a Denver linebacker who then began to run the ball upfield. The interception reversed the offensive and defensive roles of the two teams. As a result of an attempt to block Dan Park in the end zone, John Haden fell to the ground. He then turned and, with one knee on the ground and the other leg extended, watched the play continue upfield. Acting out of anger and frustration, but without a specific intent to injure, Dan Park stepped forward and struck a blow with his right forearm to the back of the kneeling plaintiff's head with sufficient force to cause both players to fall forward to the ground. Both players arose and, without comment, went to their respective teams along the sidelines. They both returned to play during the second half of the game. Because no official observed it, no foul was called on the disputed play and John Haden made no report of this incident to his coaches or to anyone else during the game. Mr. Haden experienced pain and soreness to the extent that he was unable to play golf as he had planned on the day after the game, he did not seek any medical attention and, although he continued to feel pain, he played on specialty team assignments for the Denver Broncos in games against the Chicago Bears and the San Francisco Forty-Niners on successive Sundays. The Denver Broncos then released Mr. Haden on waivers and he was not claimed by any other team. After losing his employment, Mr. Haden sought medical assistance, at which time it was discovered that he had a neck injury.

Has Park committed any torts for which Mr. Haden can recover? Why or why not?

Self-Defense

Different jurisdictions have developed diverse boundaries for the privileges associated with defending oneself against the threat of bodily injury, but all have some version of a defense that allows the defendant to use force for their own protection. Some may permit the use of deadly force, some permit only “proportional” or “reasonable” efforts, and others have rules that vary depending on whether one can retreat to one’s car or home, for instance. This is an area of tort law which intersects with criminal law; a self-defense claim may be brought either in response to a civil claim or in response to criminal prosecution or both.

Almost all jurisdictions have some means of distinguishing a responsive and necessary use of force from an antagonizing or escalating response. If the original aggressor has retreated, for instance, the person who wishes to benefit from self-defense cannot attack the person by stabbing them in the back or throwing a weapon in their direction; their perceived need for protection has been eliminated with the aggressor’s retreat. Similarly, plotting an elaborate later response in consequence of ongoing bullying does not count as self-defense; the law expects a victim of regular bullying to use other means of protection such as reporting to relevant authorities. Self-defense is thus a highly structured defense limited to imminent and reasonably perceived threats and actions that would cause the claimant physical harm. Once the existence of those can be proven, the person seeking to exercise the defense will be protected within the bounds of the rules in their jurisdiction.

McMurrey Corp. v. Yawn, Court of Civil Appeals of Texas, Texarkana (1940) (143 S.W.2d 664)

Addie Yawn, surviving wife, and the minor children of Girardus H. Yawn, appellees, instituted this suit against the McMurrey Corporation, the McMurrey Petroleum Corporation, the McMurrey Interests, the McMurrey Pipe Line Company, the McMurrey Refining Company, Marvin H. McMurrey, Jim McMurrey, and Lucille McMurrey, for damages occasioned by the alleged wrongful death of Girardus H. Yawn, hereinafter referred to as deceased. It was alleged that the McMurreys were partners, joint adventurers, or joint associates in the ownership and operation of certain oil properties located in Rusk County, among which was the oil lease known as the Pinkston lease, and that one Rudolph Loesewitz was employed by them to guard, supervise and manage said lease; that said Loesewitz as their agent and while acting within the scope or apparent scope of his authority as watchman, manager and operator of said lease, and not in his own self-defense, negligently and carelessly shot and killed deceased. In the alternative it was alleged that the killing of deceased was intentionally brought about by the conspiracy of the McMurreys acting by and through their agent, Loesewitz. All the McMurreys including the several companies answered denying partnership, and all except Jim McMurrey denied that Loesewitz was their employee or agent in any capacity. Jim McMurrey answered that after he purchased the Pinkston lease he employed Loesewitz to look after said lease “generally” and to flow the oil wells located thereon; that at the time Loesewitz killed deceased, he, Loesewitz, “was outside of his employment or the scope of his employment by this defendant; that said Rudolph Loesewitz, at the time of such killing, and immediately prior thereto, was acting in his own self-defense, for all of which this defendant is in no way liable for damages or any part of the damages sued for herein.”

The record reflects that deceased operated and managed the Pinkston lease before it was purchased by Jim McMurrey. Shortly after its purchase he was discharged, and Loesewitz was employed in his stead. While deceased was working on the Pinkston lease he lived in a house located thereon. This house was purchased either by Jim McMurrey or some one for him, and was being moved on the day deceased was killed. Deceased had removed from the lease before his death. Loesewitz also lived in a house located on the lease about 200 or 300 feet from the house formerly occupied by deceased. After deceased had been discharged by appellant and before his death, some of the oil wells located on this lease had on two occasions been turned on at night, causing the tanks to overflow. Loesewitz thought that deceased was the party who turned on the wells and he so informed Jim McMurrey. On the day of the killing Loesewitz was informed that deceased was on the lease near the house where he had formerly lived. On receiving this information Loesewitz took his shotgun, went to where deceased was, and after speaking a few words to him shot and killed him. Loesewitz testified that threats by deceased to take his life had been, on two occasions, communicated to him; one on the night before, and the other a few minutes before the killing. Loesewitz also testified that, at the time of the killing, deceased by acts committed evidenced an intention to carry said threats into execution and that he shot him in self-defense. It later developed, however, that deceased was unarmed. The jury verdict upon special issues and the judgment rendered thereon were for appellees and against defendants Jim McMurrey, M. H. McMurrey, and the McMurrey Corporation, jointly and severally, who prosecute this appeal. The other defendants were dismissed from the case.

This action was brought under Article 4671, Sec. 1, R.C.S., by the dependents of deceased for damages for his alleged wrongful killing by Loesewitz. The evidence is undisputed that the killing of deceased was intentional and not the result of negligence. Self-defense was relied on as a justification for said killing. The court below charged the jury as follows:

“You are charged that by the term ‘wrongful’ as used in Special Issue No. 1, means the use of a greater degree of force than was reasonable and necessary under the circumstances then existing.

“Now bearing in mind the foregoing definitions and instructions, you will answer *666 the following special issues, to-wit: Special Issue No. 1:

“Do you find from a preponderance of the evidence that the action of Rudolph Loesewitz in shooting and killing the deceased, Girardus H. Yawn, was wrongful? Answer Yes or No.”

Jury answer: “Yes.”

By proposition No. 9 appellants challenge the correctness of this definition when applied to the facts and circumstances surrounding the defense of self-defense as shown by the testimony in the record.

Appellants’ proposition is: “In a civil suit to recover damages for the alleged wrongful death of the deceased, where the defendant’s pleadings and evidence raise the issue that the deceased had made threats against the life of the defendant, which were communicated to the defendant, and that, by the demonstration made by the deceased, the defendant believed the deceased intended to carry out such threat, and, in defense of himself, he killed the deceased, it is error for the court to submit to the jury the bald question whether the action of the defendant in killing the deceased was wrongful, without instructing the jury upon the law of threats and self-defense and justifiable homicide. An instruction

that the term ‘wrongful’, as used in the question, means the use of a greater degree of force than is reasonable and necessary under the circumstances then existing, is entirely inadequate, misleading, and gives to the jury the impression that the killing of the deceased was the exercise of a greater degree of force than was necessary, and was, therefore, wrongful.”

If Loesewitz was acting in his own self-defense at the time he shot and killed deceased, the killing in law would not be wrongful but justifiable. This is true in a civil action as well as in a criminal action. It was said in the early case of *March v. Walker*, 48 Tex. 372: “The law of self-defense is the same as in a criminal prosecution, with the exception of the rule of evidence which, in a criminal cause, gives the defendant the benefit of a reasonable doubt. That doubt, however, is as to the facts,—not as to the extent of the right. The stage of the difficulty at which self-defense ceases is just the same, whether the question be investigated civilly or criminally.”

[***] Loesewitz testified that he thought deceased on two occasions at night had turned on the oil wells located on said lease, causing the oil tanks to overflow; that he had deceased make tracks for comparison with “boot tracks” found near the oil wells; that he reported to the sheriff’s office of Rusk County and to the officers of the Railroad Commission that said oil wells had been turned on. Loesewitz testified further that he went to see the district attorney of Rusk County for the purpose of having deceased placed under a peace bond to avoid having trouble with him. On the night before deceased was killed Loesewitz testified that his (Loesewitz’s) wife told him that deceased “was coming on the lease and get me”; that about fifteen minutes before the killing “T.M. Hill came up and told me that Buck Yawn (deceased) was down on the lease and had a gun and was going to—he said, ‘going to kill you the first time he saw you.’”

Loesewitz testified further:

“Q. When Hill told you that, what did you do?

A. I got me a gun and went down there to get him to carry him to town.

“Q. Well, how near did you get to him before you saw him?

A. I judge between 20 and 30 steps.

“Q. Did you say steps?

A. I said steps but I mean feet, between 20 and 30 feet.

“Q. What did you say to him, if anything?

A. I said, ‘All right, Buck come and go with me, you are going to town.’

“Q. What did he do, if anything?

A. He made about two steps and went left hand to his waist—

“Q. What did you say or do, if anything?

A. I did not say anything or do anything, I just raised my gun and shot.

“Q. Then what did you do?

A. I turned around and went to the Lispen Gasoline plant and called the sheriff’s department and told them to call Jim McMurrey, told them about what had happened.

*667 “Q. Who was the first person you saw after you had shot Buck Yawn?

A. My wife—I believe it was my wife.

“Q. Do you know Mr. Lerner?

A. Yes, I know him.

“Q. Did you see him first or your wife?

A. I can not say for sure whether it was him or my wife.

“Q. What statement, if any, did you make to Mr. Lerner about Buck?

A. The same statement I made to everyone, the only statement I made was to go and watch him and don't let them take that gun off of him.

“Q. How long was that after you had fired the shot that had killed Buck Yawn?

A. About as long as it would take you to walk around—say 100 feet.

“Q. What was Buck Yawn doing, just prior to the time that you fired the shot that killed him?

A. He was walking toward me.

“Q. Was he doing anything else?

A. Well, when I first seen him he had his back towards me and was walking off.

“Q. When he started towards you what movement did he make with his hands?

A. He went left-handed for his shirt, like he was going in his shirt after something.

“Q. What did you think he was going to do?

A. I thought my time had come; I thought he would probably kill me.

“Q. What did you think he was going to kill you with?

A. I thought he had a gun in his belt.

“Q. Did you know the reputation that Buck Yawn bore in that neighborhood, and in that vicinity, for being a law-abiding man?

A. I had heard about him toting a pistol and shooting out lights out of those honkey-tonks up and down the highway.

“Q. When you put the Ford pick-up in the Rushing garage and walked home, who was it that you were afraid of that night, who was it you were afraid would come, or might?

A. Well my wife told me it was Buck Yawn.

“Q. From what your wife had told you about what was going on up at the store, they were going to get you that night, you left it there because you were afraid that Buck Yawn and whoever might be with him would come?

A. Yes.

“Q. That was Friday night before the killing on Saturday?

A. Yes, sir. ”

This testimony, in our opinion, clearly raises the issue of communicated threats and self-defense, and the court's definition of the term “wrongful” as applied to the facts in this case is incorrect. If at the time of the killing the deceased by his acts and conduct reasonably induced Loesewitz to believe that deceased was about to attack him with a deadly weapon which would probably cause Loesewitz' death or some serious bodily injury; or if by the acts of the deceased it reasonably appeared to Loesewitz at the time, viewed from his standpoint alone, that deceased was then about to attack him with a deadly

weapon which would probably cause Loesewitz' death or some serious bodily injury, and if same was reasonably calculated to create in the mind of Loesewitz, and did create in his mind, a reasonable expectation of fear of death or some serious bodily injury, and that Loesewitz then and there moved and actuated by such reasonable expectation of fear of death or serious bodily injury, shot and killed deceased, then under such circumstances the killing would be in his lawful self-defense and would not be "wrongful."

Where a person accused of murder seeks to justify himself on the ground of threats against his own life, he may be permitted to introduce evidence of the threats made, but the same shall not be regarded as affording a justification for the offense, unless it be shown that at the time of the homicide the person killed by some act then done manifested an intention to execute the threats so made. If deceased did make threats against the life of Loesewitz and at the time of the killing deceased made such an act or demonstration as reasonably to produce in the mind of Loesewitz, viewed from his standpoint at the time, a belief that deceased then and there intended to execute such threats and to take the life of Loesewitz, or to do him some serious bodily harm, then the killing would not be "wrongful." It is not essential to the right of self-defense that real danger should exist. If from Loesewitz' standpoint, taking into consideration all the facts and circumstances surrounding the parties, it reasonably appeared to him that he was in danger of death or serious bodily injury, under the law he had the right to defend against such apparent danger to the same extent as if the danger were real, and if he shot and killed the deceased under such circumstances the killing would not be "wrongful." *668 [c]. This omission from the definition of the term "wrongful" in the court's charge preceding Special Issue No. 1 is vital, and calls for a reversal of this case. [cc] The converse of the above is also true; that is to say, if Loesewitz used a greater degree of force than was reasonable and necessary under the circumstances existing at the time of the killing and was not acting in his own necessary self-defense as explained above, the killing would be "wrongful."

[***] The judgment is reversed, and the cause remanded.

Note 1. In what way is the jury instruction the lower court gives in *McMurrey Corp. v. Yawn* erroneous? Do you think that the omission of a single word is likely to make a difference in a jury verdict concerning the lawfulness of a killing? Why or why not?

Note 2. How does the court define wrongfulness? Is it through use of a rule or standard? Whose perspective of the circumstances does the court adopt, or through what standard does the court consider self-defense?

Note 3. Defense of Others. A similar privilege to defend others from harmful or offensive contact exists so long as the intervention is necessary for the protection of the third person. Usually the circumstances must be the same as those necessary to justify self-defense; the idea is that the defender steps into the shoes of the person they are defending and thus the same inquiries will be asked, only they will apply to the defender, not the victim. The proportionality principle is usually the same (although in some jurisdictions the scope of the privilege to defend others is narrower than the scope of self-defense).

Defense of Property

Restatement (Second) of Torts § 77 Defense of Possession by Force Not Threatening Death or Serious Bodily Harm

An actor is privileged to use reasonable force, not intended or likely to cause death or serious bodily harm, to prevent or terminate another's intrusion upon the actor's land or chattels, if

- (a) **the intrusion is not privileged or the other** intentionally or negligently causes the actor to believe that it is not privileged, **and**
- (b) the actor **reasonably** believes that the intrusion can be prevented or terminated **only** by the force used, and
- (c) **the actor has** first requested the other to desist and the other has disregarded the request, **or the** actor reasonably believes that a request will be useless **or that** substantial harm will be done before it can be made.

Katko v. Briney, Supreme Court of Iowa (1971) (183 N.W.2d 657)

The primary issue presented here is whether an owner may protect personal property in an unoccupied boarded-up farmhouse against trespassers and thieves by a spring gun capable of inflicting death or serious injury.

We are not here concerned with a man's right to protect his home and members of his family. Defendants' home was several miles from the scene of the incident to which we refer *infra*. *658 Plaintiff's action is for damages resulting from serious injury caused by a shot from a 20-gauge spring shotgun set by defendants in a bedroom of an old farmhouse which had been uninhabited for several years. Plaintiff and his companion, Marvin McDonough, had broken and entered the house to find and steal old bottles and dated fruit jars which they considered antiques.

At defendants' request plaintiff's action was tried to a jury consisting of residents of the community where defendants' property was located. The jury returned a verdict for plaintiff and against defendants for \$20,000 actual and \$10,000 punitive damages. After careful consideration of defendants' motions for judgment notwithstanding the verdict and for new trial, the experienced and capable trial judge overruled them and entered judgment on the verdict. Thus we have this appeal by defendants. [***]

Most of the facts are not disputed. In 1957 defendant Bertha L. Briney inherited her parents' farm land in Mahaska and Monroe Counties. Included was an 80-acre tract in southwest Mahaska County where her grandparents and parents had lived. No one occupied the house thereafter. Her husband, Edward, attempted to care for the land. He kept no farm machinery thereon. The outbuildings became dilapidated. For about 10 years, 1957 to 1967, there occurred a series of trespassing and housebreaking events with loss of some household items, the breaking of windows and 'messing up of the property in general'. The latest occurred June 8, 1967, prior to the event on July 16, 1967 herein involved.

Defendants through the years boarded up the windows and doors in an attempt to stop the intrusions. They had posted 'no trespass' signs on the land several years before 1967. The nearest one was 35 feet from the house. On June 11, 1967 defendants set 'a shotgun trap' in the north bedroom. After Mr. Briney cleaned and oiled his 20-gauge shotgun, the power of which he was well aware, defendants took it to the old house where they secured it to an iron bed with the barrel pointed at the bedroom door. It was rigged with wire from the doorknob to the gun's trigger so it would fire when the door was opened. Briney first pointed the gun so an intruder would be hit in the stomach but at Mrs. Briney's suggestion it was lowered to hit the legs. He admitted he did so 'because I was mad and tired of being tormented' but 'he did not intend to injure anyone'. He gave an explanation of why he used a loaded shell and set it to hit a person already in the house. Tin was nailed over the bedroom window. The spring gun could not be seen from the outside. No warning of its presence was posted.

Plaintiff lived with his wife and worked regularly as a gasoline station attendant in Eddyville, seven miles from the old house. He had observed it for several years while hunting in the area and considered it as being abandoned. He knew it had long been uninhabited. In 1967 the area around the house was covered with high weeds. Prior to July 16, 1967 plaintiff and McDonough had been to the premises and found several old bottles and fruit jars which they took and added to their collection of antiques. On the latter date about 9:30 p.m. they made a second trip to the Briney property. They entered the old house by removing a board from a porch window which was without glass. While McDonough was looking around the kitchen area plaintiff went to another part of the house. As he started to open the north bedroom door the shotgun went off striking him in the right leg above the ankle bone. Much of his leg, including part of the tibia, was blown away. Only by McDonough's *659 assistance was plaintiff able to get out of the house and after crawling some distance was put in his vehicle and rushed to a doctor and then to a hospital. He remained in the hospital 40 days.

Plaintiff's doctor testified he seriously considered amputation but eventually the healing process was successful. Some weeks after his release from the hospital plaintiff returned to work on crutches. He was required to keep the injured leg in a cast for approximately a year and wear a special brace for another year. He continued to suffer pain during this period. There was undenied medical testimony plaintiff had a permanent deformity, a loss of tissue, and a shortening of the leg.

The record discloses plaintiff to trial time had incurred \$710 medical expense, \$2056.85 for hospital service, \$61.80 for orthopedic service and \$750 as loss of earnings. In addition thereto the trial court submitted to the jury the question of damages for pain and suffering and for future disability.

Plaintiff testified he knew he had no right to break and enter the house with intent to steal bottles and fruit jars therefrom. He further testified he had entered a plea of guilty to larceny in the nighttime of property of less than \$20 value from a private building. He stated he had been fined \$50 and costs and paroled during good behavior from a 60-day jail sentence. Other than minor traffic charges this was plaintiff's first brush with the law. On this civil case appeal it is not our prerogative to review the disposition made of the criminal charge against him.

The main thrust of defendants' defense in the trial court and on this appeal is that 'the law permits use of a spring gun in a dwelling or warehouse for the purpose of preventing the unlawful entry of a burglar or thief'. [***]

In the statement of issues the trial court stated plaintiff and his companion committed a felony when they broke and entered defendants' house.

- In instruction 2 the court referred to the early case history of the use of spring guns and stated under the law their use was prohibited except to prevent the commission of felonies of violence and where human life is in danger. The instruction included a statement breaking and entering is not a felony of violence.
- Instruction 5 stated: ‘You are hereby instructed that one may use reasonable force in the protection of his property, but such right is subject to the qualification that one may not use such means of force as will take human life or inflict great bodily injury. Such is the rule even though the injured party is a trespasser and is in violation of the law himself.’
- Instruction 6 stated: ‘An owner of premises is prohibited from willfully or intentionally injuring a trespasser by means of force that either takes life or inflicts great bodily injury; and therefore a person owning a premise is prohibited from setting out ‘spring guns’ and like dangerous devices which will likely take life or inflict great bodily injury, for the purpose of harming trespassers. The fact that the trespasser may be acting in violation of the law does not change the rule. The only time when such conduct of setting a ‘spring gun’ or a like dangerous device is justified would be when the trespasser was committing a felony of violence or a felony punishable by death, or where the trespasser was endangering human life by his act.’
- Instruction 7, to which defendants made no objection or exception, stated: ‘To entitle the plaintiff to recover for compensatory damages, the burden of proof is upon him to establish by a preponderance of the evidence each and all of the following propositions:

‘1. That defendants erected a shotgun trap in a vacant house on land owned by defendant, *660 Bertha L. Briney, on or about June 11, 1967, which fact was known only by them, to protect household goods from trespassers and thieves.

‘2. That the force used by defendants was in excess of that force reasonably necessary and which persons are entitled to use in the protection of their property.

‘3. That plaintiff was injured and damaged and the amount thereof.

‘4. That plaintiff’s injuries and damages resulted directly from the discharge of the shotgun trap which was set and used by defendants.’

The overwhelming weight of authority, both textbook and case law, supports the trial court’s statement of the applicable principles of law. [***]

Restatement of Torts, section 85, page 180, states: ‘The value of human life and limb, not only to the individual concerned but also to society, so outweighs [sic] the interest of a possessor of land in excluding from it those whom he is not willing to admit thereto that a possessor of land has, as is stated in s 79, no privilege to use force intended or likely to cause death or serious harm against another whom the possessor sees about to enter his premises or meddle with his chattel, unless the intrusion threatens death or serious bodily harm to the occupiers or users of the premises. * * * A possessor of land cannot do indirectly and by a mechanical device that which, were he present, he could not do immediately and in person. Therefore, he cannot gain a privilege to install, for the purpose of protecting his land from intrusions harmless to the lives and limbs of the occupiers or users of it, a mechanical device whose only purpose is to inflict death or serious harm upon such as may intrude, by giving notice of his intention to inflict,

by mechanical means and indirectly, harm which he could not, even after request, inflict directly were he present.’

In Volume 2, Harper and James, *The Law of Torts*, section 27.3, pages 1440, 1441, this is found: ‘The possessor of land may not arrange his premises intentionally so as to cause death or serious bodily harm to a trespasser. The possessor may of course take some steps to repel a trespass. If he is present he may use force to do so, but only that amount which is reasonably necessary to effect the repulse. Moreover if the trespass threatens harm to property only—even a theft of property—the possessor would not be privileged to use deadly force, he may not arrange his premises so that such force will be inflicted by mechanical means. If he does, he will be liable even to a thief who is injured by such device.’

[Omitting review of additional cases holding property owners liable for harms committed to entrants on land through use of excessive force omitted]

In Wisconsin, Oregon and England the use of spring guns and similar devices is specifically made unlawful by statute. [c]

***662** The legal principles stated by the trial court in instructions 2, 5 and 6 are well established and supported by the authorities cited and quoted supra. There is no merit in defendants’ objections and exceptions thereto. Defendants’ various motions based on the same reasons stated in exceptions to instructions were properly overruled.

Plaintiff’s claim and the jury’s allowance of punitive damages, under the trial court’s instructions relating thereto, were not at any time or in any manner challenged by defendants in the trial court as not allowable. We therefore are not presented with the problem of whether the \$10,000 award should be allowed to stand. [***] Study and careful consideration of defendants’ contentions on appeal reveal no reversible error. Affirmed.

LARSON, Justice.

I respectfully dissent, first, because the majority wrongfully assumes that by installing a spring gun in the bedroom of their unoccupied house the defendants intended to shoot any intruder who attempted to enter the room. Under the record presented here, that was a fact question. Unless it is held that there property owners are liable for any injury to an intruder from such a device regardless of the intent with which it is installed, liability under these pleadings must rest upon two definite issues of fact, i.e., did the defendants intend to shoot the invader, and if so, did they employ unnecessary and unreasonable force against him?

It is my feeling that the majority oversimplifies the impact of this case on the law, not only in this but other jurisdictions, ***663** and that it has not thought through all the ramifications of this holding. There being no statutory provisions governing the right of an owner to defend his property by the use of a spring gun or other like device, or of a criminal invader to recover punitive damages when injured by such an instrumentality while breaking into the building of another, our interest and attention are directed to what should be the court determination of public policy in these matters. On both issues we are faced with a case of first impression. We should accept the task and clearly establish the law in this jurisdiction hereafter. I would hold there is no absolute liability for injury to a criminal intruder by setting up such a device on his property, and unless done with an intent to kill or seriously injure the

intruder, I would absolve the owner from liability other than for negligence. I would also hold the court had no jurisdiction to allow punitive damages when the intruder was engaged in a serious criminal offense such as breaking and entering with intent to steal.

It appears to me that the learned trial court was and the majority is now confused as to the basis of liability under the circumstances revealed. Certainly, the trial court's instructions did nothing to clarify the law in this jurisdiction for the jury. Timely objections to Instructions Nos. 2, 5 and 6 were made by the defendants, and thereafter the court should have been aware of the questions of liability left unresolved, i.e., whether in this jurisdiction we by judicial declaration bar the use in an unoccupied building of spring guns or other devices capable of inflicting serious injury or death on an intruder regardless of the intent with which they are installed, or whether such an intent is a vital element which must be proven in order to establish liability for an injury inflicted upon a criminal invader.

Although the court told the jury the plaintiff had the burden to prove 'That the force used by defendants was in excess of that force reasonably necessary and which persons are entitled to use in the protection of their property', it utterly failed to tell the jury it could find the installation was not made with the intent or purpose of striking or injuring the plaintiff. There was considerable evidence to that effect. As I shall point out, both defendants stated the installation was made for the purpose of scaring or frightening away any intruder, not to seriously injure him. It may be that the evidence would support a finding of an intent to injure the intruder, but obviously that important issue was never adequately or clearly submitted to the jury.

Unless, then, we hold for the first time that liability for death or injury in such cases is absolute, the matter should be remanded for a jury determination of defendant's intent in installing the device under instructions usually given to a jury on the issue of intent. In the case at bar the plaintiff was guilty of serious criminal conduct, which event gave rise to his claim against defendants. Even so, he may be eligible for an award of compensatory damages which so far as the law is concerned redresses him and places him in the position he was prior to sustaining the injury. The windfall he would receive in the form of punitive damages is bothersome to the principle of damages, because it is a response to the conduct of the defendants rather than any reaction to the loss suffered by plaintiff or any measurement of his worthiness for the award.

When such a windfall comes to a criminal as a result of his indulgence in serious criminal conduct, the result is intolerable and indeed shocks the conscience. If we find the law upholds such a result, the criminal would be permitted by operation of law to profit from his own crime. [***] We cannot in good conscience ignore the conduct of the plaintiff. He does not come into court with clean hands, and attempts to make a claim to punitive damages in part on his own criminal conduct. In such circumstances, to enrich him would be unjust, and compensatory damages in such a case itself would be a sufficient deterrent to the defendant or others who might intend to set such a device. [***]

The admonitory function of the tort law is adequately served where the compensatory damages claimed are high and the granted award itself may act as a severe punishment and a deterrence. In such a case as we have here there is no need to hold out the prospect of punitive damages as an incentive to sue and rectify a minor physical damage such as a redress for lost dignity. Certainly this is not a case where defendants might profit in excess of the amount of reparation they may have to pay. In a case of this kind there is no overwhelming social purpose to be achieved by punishing defendants beyond the compensatory sum claimed for damages.

Note 1. How does what you have learned about the rules of defense stack up against the use of mechanized instruments of harm such as spring guns? Does it matter if the spring guns are likely to be lethal or merely to cause danger? Can you think of any conditions in which traps or mechanisms that intentionally cause physical harm might be lawful under tort law's various defense principles?

Note 2. Review the jury instructions cited in *Katko*. If you were a juror with only lay experience and no legal knowledge, do you think they would be straightforward to apply? What if anything do you think would help improve them?

Note 3. The dissent takes a strongly critical view of Katko's status on the property: he was a trespasser (not doing so for the first time), and a burglar. To what extent should the interaction of the criminal and civil systems' purposes be weighed against each other in determinations of both liability and damages in tort law? Does the majority get this right or are you more persuaded by the dissent? Note that this edited version mostly omits discussion of the punitive damages Katko had been granted and which were not properly appealed, and thus were not reversed. These "extra" damages were part of what drove the dissenting opinion. The Brineys did not have the resources to pay the court-ordered damages and had to sell 80 of their 120 acres to pay the judgment. The decision generated public rebuke and various states introduced laws strengthening self-defense provisions. These "Briney Bills" were not always passed and in at least one case, one was passed but struck down as unconstitutional.

Public Necessity

Surocco v. Geary, Supreme Court of California (1853) (3 Cal. 69)

This was an action, commenced in the court below, to recover damages for blowing up and destroying the plaintiffs' house and property, during the fire of the 24th of December, 1849.

Geary, at that time Alcalde of San Francisco, justified, on the ground that he had the authority, by virtue of his office, to destroy said building, and also that it had been blown up by him to stop the progress of the conflagration then raging.

It was in proof, that the fire passed over and burned beyond the building of the plaintiffs', and that at the time said building was destroyed, they were engaged in removing their property, and could, had they not been prevented, have succeeded in removing more, if not all of their goods. The cause was tried by the court sitting as a jury, and a verdict rendered for the plaintiffs, from which the defendant prosecutes this appeal under the Practice Act of 1850.

The only question for our consideration is, whether the person who tears down or destroys the house of another, in good faith, and under apparent necessity, during the time of a conflagration, for the purpose of saving the buildings adjacent, and stopping its progress, can be held personally liable in an action by the owner of the property destroyed.

***73** This point has been so well settled in the courts of New York and New Jersey, that a reference to those authorities is all that is necessary to determine the present case. The right to destroy property, to prevent the spread of a conflagration, has been traced to the highest law of necessity, and the natural

rights of man, independent of society or civil government. "It is referred by moralists and jurists to the same great principle which justifies the exclusive appropriation of a plank in a shipwreck, though the life of another be sacrificed; with the throwing overboard goods in a tempest, for the safety of a vessel; with the trespassing upon the lands of another, to escape death by an enemy. It rests upon the maxim, *Necessitas inducit privilegium quod jura privata.*"

The common law adopts the principles of the natural law, and places the justification of an act otherwise tortious precisely on the same ground of necessity. [c] This principle has been familiarly recognized by the books from the time of the saltpetre case, and the instances of tearing down houses to prevent a conflagration, or to raise bulwarks for the defence of a city, are made use of as illustrations, rather than as abstract cases, in which its exercise is permitted. At such times, the individual rights of property give way to the higher laws of impending necessity.

A house on fire, or those in its immediate vicinity, which serve to communicate the flames, becomes a nuisance, which it is lawful to abate, and the private rights of the individual yield to the considerations of general convenience, and the interests of society. Were it otherwise, one stubborn person might involve a whole city in ruin, by refusing to allow the destruction of a building which would cut off the flames and check the progress of the fire, and that, too, when it was perfectly evident that his building must be consumed.

The respondent has invoked the aid of the constitutional provision which prohibits the taking of private property for public use, without just compensation being made therefor. This is not "a taking of private property for public use," within the meaning of the Constitution. The right of taking individual property for public purposes *74 belongs to the State, by virtue of her right of eminent domain, and is said to be justified on the ground of state necessity; but this is not a taking or a destruction for a public purpose, but a destruction for the benefit of the individual or the city, but not properly of the State. The counsel for the respondent has asked, who is to judge of the necessity of the destruction of property? This must, in some instances, be a difficult matter to determine.

The necessity of blowing up a house may not exist, or be as apparent to the owner, whose judgment is clouded by interest, and the hope of saving his property, as to others. In all such cases the conduct of the individual must be regulated by his own judgment as to the exigencies of the case. If a building should be torn down without apparent or actual necessity, the parties concerned would undoubtedly be liable in an action of trespass. But in every case the necessity must be clearly shown. It is true, many cases of hardship may grow out of this rule, and property may often in such cases be destroyed, without necessity, by irresponsible persons, but this difficulty would not be obviated by making the parties responsible in every case, whether the necessity existed or not.

The legislature of the State possess[es] the power to regulate this subject by providing the manner in which buildings may be destroyed, and the mode in which compensation shall be made; and it is to be hoped that something will be done to obviate the difficulty, and prevent the happening of such events as those supposed by the respondent's counsel. In the absence of any legislation on the subject, we are compelled to fall back upon the rules of the common law.

The evidence in this case clearly establishes the fact, that the blowing up of the house was necessary, as it would have been consumed had it been left standing. The plaintiffs cannot recover for the value of the goods which they might have saved; they were as much subject to the necessities of the occasion as the house in which they were situate; and if in such cases a party was held liable, it would too

frequently happen, that the delay caused by the removal of the goods would render the destruction of the house useless.

***75** The court below clearly erred as to the law applicable to the facts of this case. The testimony will not warrant a verdict against the defendant. Judgment reversed.

Note 1. Can you think of other doctrines you have learned that might be relevant here, or other areas in which you have encountered limitations on tort liability that are traceable to concerns like those in *Surocco*? What justifications, and what sorts of tradeoffs, do situations like this one involve, for tort law? That is, in circumstances in which dangers are present, hazards are developing rapidly or changing, and the parties possess only imperfect information, the risks of any decision are high yet proceeding with the regular amounts of caution may impose unacceptable delays and costs. How should tort law balance these competing concerns?

Note 2. Note that this case predates The California Tort Claims Act (1963) in which the state government waived some sovereign immunity, though not all; municipal entities would likely have been unreachable at this time other than by suing the individuals involved, as in this case. Nonetheless, in the way that the *Surocco* court applies the substantive law, it effectively carves a sphere of discretionary decisionmaking for the Alcalde that shares common ground with the discretionary function exception you have learned about above.

Note 3. Constitutional questions. What concerns might you have regarding the seizure of private property by government officials? What sort of proof should be required of governments asserting this defense? The “Takings Clause” under the Fifth Amendment of the United States Constitution prevents the federal government from taking “private property” even “for public use, without just compensation.” The Fourteenth Amendment extends the Fifth Amendment to state governments. Ordinarily, then if the government uses or destroys private property, even for public use, it must pay “just compensation.” How well do you think tort law’s “public necessity” defense squares with this constitutional protection?

Private Necessity

Vincent v. Lake Erie Transp. Co., Supreme Court of Minnesota. (1910) (109 Minn. 456)

The steamship Reynolds, owned by the defendant, was for the purpose of discharging her cargo on November 27, 1905, moored to plaintiff’s dock in Duluth. While the unloading of the boat was taking place a storm from the northeast developed, which at about 10 o’clock p. m., when the unloading was completed, had so grown in violence that the wind was then moving at 50 miles per hour and continued to increase during the night. There is some evidence that one, and perhaps two, boats were able to enter the harbor that night, but it is plain that navigation was practically suspended from the hour mentioned until the morning of the 29th, when the storm abated, and during that time no master would have been justified in attempting to navigate his vessel, if he could avoid doing so. After the discharge of the cargo the Reynolds signaled for a tug to tow her from the dock, but none could be obtained because of the severity of the storm. If the lines holding the ship to the dock had been cast off, she would doubtless

have drifted away; but, instead, the lines were kept fast, and as soon as one parted or chafed it was replaced, sometimes with a larger one. The vessel lay upon the outside of the dock, her bow to the east, the wind and waves striking her starboard quarter with such force that she was constantly *458 being lifted and thrown against the dock, resulting in its damage, as found by the jury, to the amount of \$500.

We are satisfied that the character of the storm was such that it would have been highly imprudent for the master of the Reynolds to have attempted to leave the dock or to have permitted his vessel to drift a way from it. One witness testified upon the trial that the vessel could have been warped into a slip, and that, if the attempt to bring the ship into the slip had failed, the worst that could have happened would be that the vessel would have been blown ashore upon a soft and muddy bank. The witness was not present in Duluth at the time of the storm, and, while he may have been right in his conclusions, those in charge of the dock and the vessel at the time of the storm were not required to use the highest human intelligence, nor were they required to resort to every possible experiment which could be suggested for the preservation of their property. Nothing more was demanded of them than ordinary prudence and care, and the record in this case fully sustains the contention of the appellant that, in holding the vessel fast to the dock, those in charge of her exercised good judgment and prudent seamanship.

It is claimed by the respondent that it was negligence to moor the boat at an exposed part of the wharf, and to continue in that position after it became apparent that the storm was to be more than usually severe. We do not agree with this position. The part of the wharf where the vessel was moored appears to have been commonly used for that purpose. It was situated within the harbor at Duluth, and must, we think, be considered a proper and safe place, and would undoubtedly have been such during what would be considered a very severe storm. The storm which made it unsafe was one which surpassed in violence any which might have reasonably been anticipated.

The appellant contends by ample assignments of error that, because its conduct during the storm was rendered necessary by prudence and good seamanship under conditions over which it had no control, it cannot be held liable for any injury resulting to the property of others, and claims that the jury should have been so instructed. An analysis of the charge given by the trial court is not necessary, as in our opinion the only question for the jury was the amount of damages *459 which the plaintiffs were entitled to recover, and no complaint is made upon that score.

The situation was one in which the ordinary rules regulating property rights were suspended by forces beyond human control, and if, without the direct intervention of some act by the one sought to be held liable, the property of another was injured, such injury must be attributed to the act of God, and not to the wrongful act of the person sought to be charged. If during the storm the Reynolds had entered the harbor, and while there had become disabled and been thrown against the plaintiffs' dock, the plaintiffs could not have recovered. Again, if, while attempting to hold fast to the dock the lines had parted, without any negligence, and the vessel carried against some other boat or dock in the harbor, there would be no liability upon her owner. But here those in charge of the vessel deliberately and by their direct efforts held her in such a position that the damage to the dock resulted, and, having thus preserved the ship at the expense of the dock, it seems to us that her owners are responsible to the dock owners to the extent of the injury inflicted.

In *Depue v. Flatau*, 100 Minn. 299, this court held that where the plaintiff, while lawfully in the defendants' house, became so ill that he was incapable of traveling with safety, the defendants were

responsible to him in damages for compelling him to leave the premises. If, however, the owner of the premises had furnished the traveler with proper accommodations and medical attendance, would he have been able to defeat an action brought against him for their reasonable worth?

In *Ploof v. Putnam*, 71 Atl. 188, the Supreme Court of Vermont held that where, under stress of weather, a vessel was without permission moored to a private dock at an island in Lake Champlain owned by the defendant, the plaintiff was not guilty of trespass, and that the defendant was responsible in damages because his representative upon the island unmoored the vessel, permitting it to drift upon the shore, with resultant injuries to it. If, in that case, the vessel had been permitted to remain, and the dock had suffered an injury, we believe the shipowner would have been held liable for the injury done.

***460** Theologians hold that a starving man may, without moral guilt, take what is necessary to sustain life; but it could hardly be said that the obligation would not be upon such person to pay the value of the property so taken when he became able to do so. And so public necessity, in times of war or peace, may require the taking of private property for public purposes; but under our system of jurisprudence compensation must be made.

Let us imagine in this case that for the better mooring of the vessel those in charge of her had appropriated a valuable cable lying upon the dock. No matter how justifiable such appropriation might have been, it would not be claimed that, because of the overwhelming necessity of the situation, the owner of the cable could not recover its value.

This is not a case where life or property was menaced by any object or thing belonging to the plaintiff, the destruction of which became necessary to prevent the threatened disaster. Nor is it a case where, because of the act of God, or unavoidable accident, the infliction of the injury was beyond the control of the defendant, but is one where the defendant prudently and advisedly availed itself of the plaintiffs' property for the purpose of preserving its own more valuable property, and the plaintiffs are entitled to compensation for the injury done.

Order affirmed.

LEWIS, J.

I dissent. It was assumed on the trial before the lower court that appellant's liability depended on whether the master of the ship might, in the exercise of reasonable care, have sought a place of safety before the storm made it impossible to leave the dock. The majority opinion assumes that the evidence is conclusive that appellant moored its boat at respondent's dock pursuant to contract, and that the vessel was lawfully in position at the time the additional cables were fastened to the dock, and the reasoning of the opinion is that, because appellant made use of the stronger cables to hold the boat in position, it became liable under the rule that it had voluntarily made use of the property of another for the purpose of saving its own.

***461** In my judgment, if the boat was lawfully in position at the time the storm broke, and the master could not, in the exercise of due care, have left that position without subjecting his vessel to the hazards of the storm, then the damage to the dock, caused by the pounding of the boat, was the result of an inevitable accident. If the master was in the exercise of due care, he was not at fault. The reasoning of the opinion admits that if the ropes, or cables, first attached to the dock had not parted, or if, in the first instance, the master had used the stronger cables, there would be no liability. If the master could not,

in the exercise of reasonable care, have anticipated the severity of the storm and sought a place of safety before it became impossible, why should he be required to anticipate the severity of the storm, and, in the first instance, use the stronger cables?

I am of the opinion that one who constructs a dock to the navigable line of waters, and enters into contractual relations with the owner of a vessel to moor at the same, takes the risk of damage to his dock by a boat caught there by a storm, which event could not have been avoided in the exercise of due care, and further, that the legal status of the parties in such a case is not changed by renewal of cables to keep the boat from being cast adrift at the mercy of the tempest.

Note 1. Does the private necessity doctrine, expounded upon here in *Vincent*, seem to you to be consistent with, or to diverge from, the principle that there is no duty to rescue at common law? What principles does it reflect, and what concerns does it seem to try to balance?

Note 2. Does private necessity create a categorical defense (like an immunity?) or a fact-based defense (like a privilege or other form of circumstance-specific defense)? Why might this matter?

Note 3. Ideological Underpinnings of the Necessity Doctrines. Consider the moral and philosophical values expressed in the public and private necessity doctrines as defenses to trespass. These defenses take a position on the value and objective defensibility of various actions that may seem subjectively necessary to the actor at the time of the unauthorized use of land or property. In a thoughtful article exploring different conceptions of property against a backdrop of cultures, political institutions and intellectual theories, Professor Monica E. Eppinger notes the constructedness of the law’s understanding of private and public uses of space. She provides a hypothetical as a means of exploring the law’s unstated commitments to certain values over others:

Four adults, desperate to find a home at an affordable cost, together with their families (including several children) inhabit homes in a development project suspended due to delayed authorizations. The four friends and their families work on both the buildings and the land to enhance their living conditions (for instance, by painting the walls and adding a little garden). After a couple of months, the legal manager of the land discovers them and brings legal action against them. Monica E. Eppinger, *The Challenge of the Commons: Beyond Trespass and Necessity*, 66 Am. J. Comp. L. 1, 17 (2018) (citations omitted)

Eppinger surveys relevant doctrines in tort and property law and explores the “necessity” defenses:

If the use were in pursuit of a public good, for example using vacant premises to provide volunteer healthcare to irregular migrants, ... the defense the defendant would assert is public rather than private necessity. ... If the defendant trespassed out of public necessity, unlike private necessity, she owes no compensation even if the property was harmed. The public necessity defense would only apply if the defendant could demonstrate she commandeered the building to avert an imminent threat to the public—for example, preventing or alleviating a deadly epidemic. ... A situation that gives rise to necessity is imagined as an “emergency” and the privilege must be exercised “in a reasonable time and in a reasonable manner.” A court during the Great Depression affirmed convictions of several in a crowd convicted of stealing groceries, over defendants’ objections that they were denied the right to present the defense of “economic necessity.” Moreover, entry into a dwelling without permission is treated with a higher degree of disfavor than entry into fields, yards, or other forms of real

property. Even if a privilege of private necessity is recognized, the trespasser is liable for damage to the property. *Id.* at 18.

Eppinger concludes that the legal manager would be successful in ousting the families on the basis of trespass. She observes:

Until homelessness is considered a matter in which parties hold a “common interest,” it is likely that the law will excuse trespass to tear down a home to save other buildings from fire as a matter of public necessity, but not excuse entry into unused dwelling spaces to save individuals from homelessness.... Such is the strength of the ideology of private property, and the dominance of the right to exclude, that in the United States, people priced out of housing markets and into homelessness do not routinely shelter in vacant buildings (as envisioned in the hypothetical), as they presume title holders to be armed with legal doctrines to facilitate evictions. *Id.* at 23.

Is homelessness exacerbated by entrenched default positions in the private law of tort and property? Are Professor Eppinger’s concerns something tort law should consider as its common law continues to develop? If so, are courts the appropriate source of change on the issue, or should changes occur at the legislative or administrative levels? If no changes are called for, what are the strongest justifications for retaining the status quo?

Check Your Understanding (2-7)

Question 1. True or False: Private necessity requires a higher standard of proof by the defendant than public necessity, because the private reputational and property interests of the plaintiff mandate higher protections.

An interactive H5P element has been excluded from this version of the text. You can view it online here: <https://saidtorts2d.lawbooks.cali.org/?p=50#h5p-45>

MODULE 3. NEGLIGENCE

Negligence is the quintessential tort claim. While its four elements—duty, breach, causation and harm—must each individually be proven as with any other tort, the heart of the action will turn on a simple question: **did the defendant do something unreasonable that harmed the plaintiff?** In a small subset of cases, an affirmative answer will not lead to liability because the defendant owed no duty to that particular plaintiff or because the harm the plaintiff suffered was not proximately caused by the defendant. In another subset of cases, liability will not attach because the plaintiff’s conduct was also negligent to a level deemed meaningful in that jurisdiction, or the plaintiff and defendant may be forced to share the costs of the harm suffered. Finally, in some cases, the defendant’s wrongful conduct will be forgiven because of some immunity available to the defendant or some flaw in the plaintiff’s case, such as failure to file within the statute of limitations. The core question of culpability, however, will always return to whether the thing the defendant did, or failed to do, requires—or should require—that the defendant be held accountable to the plaintiff who suffered as a result.

As you have already learned, “reasonableness” is a standard, not a rule, and determining what is reasonable proves to be intricate, legally, however simple the inquiry may seem on the surface. Accordingly, most torts courses dedicate the bulk of the term to understanding how to analyze and prove the second prong of negligence: **whether the defendant breached their duty of due care.** Don’t be distracted by the use of the word “duty” in this common phrasing; duty analysis concerns **whether** a defendant owes any obligations to the plaintiff in question; breach analysis concerns *what was reasonable to expect the defendant to do or refrain from doing* under the circumstances. The third prong, causation, considers **whether the particular conduct associated with the breach caused the plaintiff’s harm** and the fourth requires the plaintiff to prove that **harm did in fact occur.** Note that if the defendant **does** breach their duty of care and the plaintiff **is harmed** but the breach is not the action that **caused/strong>the harm, then the required “causal nexus”—the link in the chain of causation—is not present and the claim will fail. For example, if a surgeon performs drunk but skillfully and, unrelatedly, the anesthesiologist makes an error that it was not the surgeon’s duty or capacity to prevent or detect, the patient cannot recover against the drunk surgeon. The breach of duty implicated by performing surgery drunk will not matter for the purposes of the plaintiff’s negligence claim since the anesthesiologist’s error “severs the chain of causation.”**

Causation also includes an inquiry into **proximate cause**, which is essentially a policy determination that allows the factfinder to limit liability in certain kinds of cases. Each of these prongs involves further complexity but it is nonetheless helpful at the outset to understand what the combined effect of the inquiries is meant to yield, namely, a legal conclusion about the reasonableness of the defendant’s actions and their materiality to the plaintiff’s injuries or losses.

In the hypotheticals that follow, you will be asked to focus on one aspect of a negligence claim to reinforce the general sense you are gaining of how each one operates. The material in the cases to come will, of course, teach you the proper tests for conducting the analysis pertaining to each element. This introduction is meant to illustrate how each element operates in isolation and to help prepare you for

further study. It also may serve as a way for you to test your intuitions about the law against the existing legal rules to see where they converge or diverge.

Expand On Your Understanding – Drunken Surgeon Hypotheticals

In the hypotheticals that follow, you will be asked to focus on one aspect of a negligence claim to reinforce the general sense you are gaining of how each one operates. The material in the cases to come will, of course, teach you the proper tests for conducting the analysis pertaining to each element. This introduction is meant to illustrate how each element operates in isolation and to help prepare you for further study. It also may serve as a way for you to test your intuitions about the law against the existing legal rules to see where they converge or diverge. Turn each card to reveal the answer.

An interactive H5P element has been excluded from this version of the text. You can view it online here: <https://saidtorts2d.lawbooks.cali.org/?p=52#h5p-46>

Chapter 14. Negligence: Duty

Overview of Duty

Duty, the first of the four elements required in a negligence action, has a special character.

First, it is the only element of negligence **decided by the court as a question of law**, and thus operates as a gate-keeping mechanism to help define the contours of tort law and limit the scope of potential liability. To the extent that the system defines what tort law protects and against what, the duty inquiry has developed such that defendants do—or do not—owe a duty of care with respect to particular classes of potential plaintiffs, for particular types of losses, or on particular classes of fact patterns (since accidents occur and do fall, generally, into recognizable types). Judges decide the question of duty partly because they are thought to be better at deciding categorical kinds of questions. Judges can see recurring patterns because over the course of a career on the bench, a judge will decide and read many cases. Most jurors are likely to serve as factfinders only a few times in their lives, if ever. Jury expertise is thought to consist of everyday experience applicable to the particular facts of the single case before them. Yet judges have the capacity to “see the big picture” and categorize similar fact patterns together in light of prior similar scenarios on which the court (or other courts) have ruled. Judges also have legal training that helps them to align the policy goals of tort law with the kinds of cases that ought to be decided at this earliest point in the negligence analysis.

Second, there has been a major evolution in how duty has been conceived, and it’s relevant to your understanding of the cases courts are deciding in the present era. The standard for duty in most cases today is **whether it was foreseeable that the defendant’s actions would harm the plaintiff**. Under this modern view, if the injury was foreseeable, then the defendant owed a plaintiff a duty unless some special exception or limitation exists. However, “foreseeable” is a term just about as unhelpful as “reasonable” in the sense that its meaning is malleable. Nonetheless, that’s the general contemporary approach. Sometimes it is attributed to a late 19th century case, *Heaven v. Pender* (1883) 11 Q.B.D. 503, 509, which stated:

[W]henver one person is by circumstances placed in such a position with regard to another that every one of ordinary sense who did think would at once recognize that if he did not use ordinary care and skill in his own conduct with regard to those circumstances he would cause danger of injury to the person or property of the other, a duty arises to use ordinary care and skill to avoid such danger.

The Restatement now reflects this view: “Ordinarily, a person engaging in conduct that creates risks to others has a duty to exercise reasonable care to avoid causing them physical harm.” Restatement (Third) of Torts § 6, cmt. b (2010)

However, historically at common law, it was **virtually the opposite of this generalized view of duty**. There was rarely an independent duty for a person (P1) to act or to compensate someone (P2) for the losses P2 had suffered, unless P1 stood in a particular relationship with P2. P1 was generally not liable for “nonfeasance,” which is a formal term often meaning that a person chose to do nothing or somehow failed to act. If P1 had contracted to help or provide services for P2 and P1 didn’t perform

on that contract, P2's remedy was in contract law. If in providing services, P1 committed misconduct through unreasonable behavior ("misfeasance") and caused harm to P2, P1 had breached their duty of care and P2 could recover in tort law. Under that last scenario, there wasn't a breach of contract since P1 had technically carried out their promise to P2 under the contract even if in doing so their misconduct created new problems. Accordingly, tort law provided an alternate means of redress for a problem that wasn't breach of contract but rather some other sort of loss or injury. The *duty* in tort law arose because of the contract but the corresponding legal obligation to compensate for the injury caused by the careless fulfillment of the contract sounded in tort law. Consequently, this may have reinforced the early view that without a contract, recovery in tort was nearly impossible without some alternative source of legal obligation flowing between the parties. Indeed, that was one way courts kept the early scope of negligence law narrow.

The concept of "**privity, a contract-like relationship**," arose to define a legal relationship broader than a contract, and courts allowed tort recovery for those who "stood in privity" with one another. For instance, a customer who bought goods or chattels from a merchant stood in privity with them (despite the lack of a formal contract) but their non-purchasing spouse did not. This caused some case outcomes that seemed puzzling and unfair; why shouldn't the non-purchasing spouse be able to recover in tort law when the product caused them injury and they were very much a foreseeable user of the product? Over time, the concept of privity continued to expand in piecemeal and the restrictions on recovery relaxed until the requirement of privity, too, yielded, as you will most likely explore further if your course covers product liability law (Module 5).

In cases where there was no contract or privity, courts increasingly looked for a "**special relationship**" between parties. Under this approach, while strangers did not owe each other a duty to assist each other, those who stood in a special relationship even without a contract or privity—such as family members, close friends or members of a group engaged in an activity together—were commonly found to have a duty arising out of that special relationship. In addition, when a person voluntarily undertook a rescue of some kind (or simply stepped in to help), their actions created a duty to follow through with what they had offered, behaving reasonably under the circumstances. These means of creating a duty—through special relationships or voluntary undertakings—remain important in the legal system today.

The early 20th century witnessed the **expansion of duty to a sphere of foreseeable people** who might suffer harms from one's tortious conduct and who thus deserved compensation regardless of contract, privity or relationship. Courts routinely articulated the scope of the duty to behave reasonably in language that left no room for doubt: "[E]very person owes to all others a duty to exercise ordinary care to guard against injury which naturally flows as a reasonably probable and foreseeable consequence of his act, and ... such duty does not depend upon contract, privity of interest or the proximity of relationship, but extends to remote and unknown persons." *Nelson v. Union Wire Rope Corp.*, 31 Ill.2d 69, 86 (1964) These changes in the law largely originated in the domain of product liability law where the expansion of duty paved the way for the broader default rule that has come to be the majority rule: **everybody owes a duty of care to refrain from conduct that foreseeably harms others**.

In the contemporary era, however, stubborn exceptions to the traditional rule of no duty remain, creating a diversity of rules with regard to duty. In a subset of cases there remains **no duty** while in other areas (such as premises liability and the duty to compensate for purely emotional losses) that old

rule has been eroded over time to a patchwork of rules that create **duties to take certain steps under certain circumstances**. These have sometimes been classified as “general” versus “affirmative” duties, intended to track the categories of “misfeasance” (which there was a general duty to avoid) and “nonfeasance” (which gave rise to no duty except in cases where a so-called affirmative duty arose because of a special relationship or voluntary undertaking as noted above, or under other exceptions).

An Updated Way to Categorize Types of Duty

Although this has been the way law students were traditionally instructed on the law of duty, these terms (misfeasance/nonfeasance; general/affirmative duty) are not that useful. Students and professors alike have long found them very difficult to define and apply. Consider that “misfeasance” could include both negligently fixing your car’s brakes by going to an unlicensed irresponsible mechanic *or* failing to take action with respect to your service light’s warning that your brakes might fail soon. Yet failing to take action sounds more like “nonfeasance” which in theory gives rise to no duty. There are formalistic ways to arrive at the conclusion that in fact there *is* a duty to get your brakes fixed—cars are dangerous vehicles and some states find there is a “non-delegable duty” to make sure your vehicle is safe for driving, for instance. But that general problem of action versus inaction remains a thorny one and this division has puzzled theorists.

Beyond that, the terms are outdated and hearken back to an era when landlords owed their tenants no duty and even landowners’ duties to entrants were more tightly circumscribed. Recently, two preeminent torts scholars have called for a recognition that the “exceptions” formerly understood in terms of “affirmative duties” can be understood either as articulations of the general duty or as subsets of now well-settled law in which the default is no longer “no duty.”

These distinctions are problematic in both descriptive and normative respects. On a descriptive level, many cases of what tort law calls nonfeasance are difficult, if not impossible, to distinguish from misfeasance. Similarly, sometimes even misfeasance does not look like misfeasance; there are instances of what tort law calls misfeasance that are hard to distinguish from nonfeasance. On a normative level, meanwhile, the distinctions’ significance can be difficult to discern. Even in paradigm cases where the descriptive distinction between misfeasance and nonfeasance is clear—such as the case of the driver who hits the pedestrian versus the bystander who fails to rescue—the normative distinction can be elusive. Kenneth S. Abraham and Leslie Kendrick, *There’s No Such Thing As Affirmative Duty*, 104 Iowa L. Rev. 1649 (2019).

The challenge in offering an updated, revisionist approach to duty lies in the fact that the other resources students may consult (hornbooks, commercial outlines, bar preparation materials) and the older cases they read will likely contain some references to these outdated terms. The virtue in revisionism, however, lies in offering the opportunity for greater conceptual clarity and what is now a more accurate view of the case law. To that end, this textbook will refer to the older categories that have been used to define classes of duties and their “exceptions” (such as voluntary undertakings and special relationships; those are still “good law”). However, I dispense with the language of “affirmative duty” and, following Abraham and Kendrick, try to situate the duty cases in the legal contexts in which these contemporary rules have developed. I will not emphasize the “misfeasance” versus

“nonfeasance” distinction any further as I do not believe it is productive and years of conversations with students have persuaded me that they do not find it helpful either.

Duties By Type of Actor and Type of Harm

Special duties historically have applied to **certain classes of actors**, including **common carriers** (as you learned in Module 1 in the discussion preceding *Gulf v. Luther*), **innkeepers** and **landowners**. It was expedient for courts to determine the legal obligations of whole classes of entities in this way since the rules affected so many people. Creating predictable patterns of potential liability allowed businesses to plan for or prevent it and to conduct their operations with some amount of awareness of their likely legal risk.

In my view, there is also a **hybrid nature to the way duty is determined in cases associated with property**. Ordinarily, the question of duty is distinct from the conduct that the duty requires. For instance, to say that a common carrier has a duty (or even a heightened duty in some jurisdictions) does not specify what that requires them to do. So-called “premises liability,” which flows from the duties one has in association with maintaining property for those who enter it is unusual in that the duty may be accompanied by particular actions the duty requires (such as a duty to warn of a hidden danger or a duty to fence off a dangerous feature). That premises liability diverges from the general framework makes determining the duty of landowners unusually complex at times. Students (and courts!) find the distinctions between duty and breach of duty understandably confusing so anticipating the complexity and confusion somewhat can be helpful. With respect to landowners (as well as possessors and occupiers of land), there is a significant jurisdictional divergence you will want to keep straight so you learn and differentiate both the majority and minority approaches.

A final way that courts have modulated the scope of tort law and used duty as a gatekeeping measure is through the kinds of losses for which tort law permits recovery. Courts have consistently held that parties may not recover for purely economic losses and this has been framed in terms of duty: there is **no duty to prevent purely economic losses** to another. For most of the history of U.S. tort law, courts were reluctant to allow parties to recover for purely emotional losses, as well. That bright-line restriction has been eroded over time with the rise of actions for intentional infliction of emotional distress as well as negligent infliction of emotional distress. In practice, both torts are rarely viable alone, without other accompanying actions. In almost all jurisdictions that recognize the negligent version of the tort, the action is limited by requirements that reflect the longstanding judicial reluctance to open the floodgates to emotional distress claims more broadly. This means that there is effectively only a **limited duty to prevent purely emotional losses**; the duty will depend on a number of factors set out in a given jurisdiction.

Expand On Your Understanding – Choking Victim Duty Hypotheticals

Review the following hypotheticals. Turn each card to reveal the answer.

An interactive H5P element has been excluded from this version of the text. You can view it online here: <https://saidtorts2d.lawbooks.cali.org/?p=53#h5p-47>

Questions or Areas of Focus for the Readings

- Do you agree with where courts do and don't find that a duty exists? Descriptively? Normatively?
- Look for references to the purposes of tort law, even if you find them by "reading between the lines"; what role can you see duty playing as a factor in shaping tort policy?
- When are courts choosing to *diverge* from older rules versus pronouncing themselves constrained by prior precedents or rules? What do you notice about fact patterns in which courts do or don't announce a change?
- In what ways do you see duty analysis reflecting sociological issues or context? If you changed the gender of the parties in the cases that follow, or made race or class explicit with respect to one or the other of the parties, for instance, might the analysis change?

Chapter 15. Duty As a Function of Foreseeability (Socratic Script)

The general rule of duty depends on foreseeability. Where harms are foreseeable, both moral and legal notions suggest that it is proper to prevent them unless the costs or risks of doing so outweigh the costs or risks of *not* doing so. Efficiency, fairness, deterrence and compensation are all powerful rationales for pinning duty to foreseeability—in theory. In practice, determining what is foreseeable has commonly been an exercise in judicial policymaking with lines drawn that sometimes seem principled and coherent and other times seem outcome-driven, poorly reasoned or even incoherent.

Foreseeability has often played a role in constricting the scope of liability but it expanded the scope of duty with respect to landlord liability. Were landlords liable to their tenants and their guests, when third parties committed crimes for which the landlords were not directly responsible? The common law answer was no, reflecting the default to “no duty.” However, fifty years ago a landmark case *Kline v. 1500 Massachusetts Ave.*, 439 F.2d 477 (1970), signaled the start of courts’ willingness to find a duty in some cases of landlord responsibilities to prevent third-party crimes. The following case also provides a helpful overview of the changing notions of duty over time.

Note: The case mentions a sexual assault in the background of the fact pattern but does not dwell on or recount it beyond that.

Walls v. Oxford Management Co., Inc., Supreme Court of New Hampshire (1993) (137 N.H. 653)

[The legal question is: Does New Hampshire law impose a duty on landlords to provide security to protect tenants from the criminal attacks of third persons?]

On December 13, 1988, the plaintiff, Deanna Walls, was sexually assaulted in her vehicle, which was parked on the premises of the Bay Ridge Apartment Complex in Nashua. The plaintiff lived with her mother, who leased an apartment at Bay Ridge. Gerard Buckley was arrested and subsequently convicted of sexually assaulting the plaintiff. Bay Ridge is owned by defendant Nashua–Oxford Bay Associates Limited Partnership (Nashua–Oxford), and managed by defendant Oxford Management Company, Inc. (Oxford). It consists of 412 apartments located in fourteen buildings. During the two years prior to the assault, the Bay Ridge complex had been the site of a number of crimes directed against property, including eleven automobile thefts, three attempted automobile thefts, and thirty-one incidents involving criminal mischief/theft. No sexual assaults or similar attacks against persons had been reported.

The plaintiff brought this action in federal court, charging that the defendants “had a duty to hire and contract with a competent management company, had a duty to provide reasonable security measures for the protection of residents of Bay Ridge, a duty to warn residents of its lack of security, as well as

a duty to warn residents of the numerous criminal activities which had taken place on the premises of Bay Ridge and in the vicinity of Bay Ridge.”

The plaintiff alleges that the defendants breached these duties, and that the breach was a proximate cause of the sexual assault. *656

1. Landlord's Duty to Secure Tenants Against Criminal Attack

The issues raised by the first question [before] the court at the confluence of two seemingly contradictory principles of law. On one hand lies the accepted maxim that all persons, including landlords, have a duty to exercise reasonable care not to subject others to an unreasonable risk of harm. *See Sargent v. Ross*, 113 N.H. 388, 391 (1973). On the other hand, a competing rule holds that private persons have no general duty to protect others from the criminal acts of third persons. *See Restatement (Second) Of Torts* § 314 (1965); W. Page Keeton *et al.*, *Prosser and Keeton on the Law of Torts*, § 33, at 201 (5th ed. 1984).

Claims for negligence “rest primarily upon a violation of some duty owed by the offender to the injured party.” [c] Absent a duty, there is no negligence. Whether a duty exists in a particular case is a question of law. [cc] Only after a court has determined that a defendant owed a plaintiff a duty, and identified the standard of care imposed by that duty, may a jury consider the separate question of whether the defendant breached that duty. [c]

While of paramount importance to the analysis of a claim for negligence, duty “is an exceedingly artificial concept.” *Libbey v. Hampton Water Works Co.*, 118 N.H. 500, 502, (1978). In some cases, a party’s actions give rise to a duty. [c] A party who does not otherwise have a duty, but who voluntarily renders services for another, has been held to a duty of reasonable care in acting. [c] *Restatement (Second) Of Torts, supra* §§ 323, 324. In other cases, a duty to act exists based on a special relationship between two parties. [c] In either case, the scope of the duty imposed is limited by what risks, if any, are reasonably foreseeable. [c] As a general rule, “a defendant will not be held liable for negligence if he could not reasonably foresee that his conduct would result in an injury or if his conduct was reasonable in light of what he could anticipate.”

*657 When charged with determining whether a duty exists in a particular case, we necessarily encounter the broader, more fundamental question of “whether the plaintiff’s interests are entitled to legal protection against the defendant’s conduct.” *Libbey*, 118 N.H. at 502 (quotation omitted). The decision to impose liability ultimately rests on “a judicial determination that the social importance of protecting the plaintiff’s interest outweighs the importance of immunizing the defendant from extended liability.” *Libbey*, 118 N.H. at 502. *See generally* Keeton, *supra* § 54, at 358 (duty not sacrosanct in itself, but only expression of sum total of policy considerations).

At one time, landlords enjoyed considerable immunity from “simple rules of reasonable conduct which govern other persons in their daily activities.” *Sargent*, 113 N.H. at 391. A landlord owed no general duty to his tenants, and could be found liable for injuries caused by a defective or dangerous condition on leased property only if the injuries were “attributable to (1) a hidden danger in the premises of which the landlord but not the tenant [was] aware, (2) premises leased for public use, (3) premises retained under the landlord’s control, such as common stairways, or (4) premises negligently repaired by the landlord.” *Id.* at 392. In *Sargent*, however, this court abolished landlord immunity, and held that a landlord has a duty to act as a reasonable person under all the circumstances. *Id.* at 397. We

acknowledged that “[c]onsiderations of human safety within an urban community dictate that the landowner’s relative immunity, which is primarily supported by values of the agrarian past, be modified in favor of negligence principles of landowner liability.” *Id.* at 396 (quotation omitted).

While we can state without reservation that landlords owe a general duty of reasonable care to their tenants, our efforts at resolving the first question presented are complicated by the competing common law rule that private citizens ordinarily have no duty to protect others from criminal attacks. *See generally Restatement (Second) of Torts, supra* § 314; Keeton, *supra* § 33, at 201; *Kline v. 1500 Massachusetts Avenue Apartment Corp.*, 439 F.2d 477, 481 (D.C.Cir.1970). This rule is grounded in the fundamental unfairness of holding private citizens responsible for the unanticipated criminal acts of third parties. “Under all ordinary and normal circumstances, in the absence of any reason to expect the contrary, the actor may reasonably proceed upon the assumption that others will obey the *658 law.... Although [crimes] do occur ... they are still so unlikely that the burden of taking continual precautions against them almost always exceeds the apparent risk.” Keeton, *supra* § 33, at 201. In keeping with this rule, courts have largely refused to hold landlords to a general duty to protect tenants from criminal attack. [c]

We agree that as a general principle, landlords have no duty to protect tenants from criminal attack. Without question, there is much to be gained from efforts at curtailing criminal activity. Yet, we will not place on landlords the burden of insuring their tenants against harm from criminal attacks.

Our inquiry is not concluded, however, as we must further consider whether exceptions to the general rule against holding individuals liable for the criminal attacks of others apply to the landlord-tenant relationship. A review of the law in this area suggests four such exceptions. The first arises when a special relationship, such as that of innkeeper-guest, or common carrier-passenger, exists between the parties. *See Restatement (Second) of Torts, supra* § 314A. Courts have repeatedly held, however, that a landlord-tenant relationship is not a special relationship engendering a duty on the part of the landlord to protect tenants from criminal attack. [cc] *But see Kline v. 1500 Massachusetts Avenue*, 439 F.2d at 485 (finding landlord-tenant relationship analogous to that of innkeeper-guest).

A second exception arises where “an especial temptation and opportunity for criminal misconduct *brought about by the defendant*, will call upon him to take precautions against it.” Keeton, *supra* § 33, at 201 (emphasis added). This exception follows from the rule that a party who realizes or should realize that his conduct has created a condition which involves an unreasonable risk of harm to another has a duty to exercise reasonable care to prevent the risk from taking effect. *Restatement (Second) of Torts, supra* § 321; *see also Restatement (Second) of Torts, supra* § 448 (criminal act of third person is superseding cause of harm to another unless defendant could have foreseen that his negligent conduct increased risk of crime). Accordingly, in the majority of cases in which a landlord has *659 been held liable for a criminal attack upon a tenant, a known physical defect on the premises foreseeably enhanced the risk of that attack. *See, e.g., Braitman v. Overlook Terrace Corp.*, 68 N.J. 368, 377, 381 (1975) (defective deadbolt on apartment door); *Aaron*, 758 S.W.2d at 446 (broken window latch); *Duncavage v. Allen*, 147 Ill.App.3d 88 (1986) (inoperable lighting; ladder left unattended near unlocked window).

A third exception is the existence of overriding foreseeability. Some courts have held landlords to a duty to protect tenants from criminal attacks that were clearly foreseeable, even if not causally related to physical defects on the premises. *See, e.g., Trentacost v. Brussel*, 82 N.J. 214, 218 (1980) (criminal

activity apparent in plaintiff's neighborhood); *Holley v. Mt. Zion Terrace Apartments, Inc.*, 382 So.2d 98, 100 (Fla.App.1980) (apartment complex plagued by high incidence of serious crime); *Kline v. 1500 Massachusetts Avenue*, 439 F.2d at 483 (crimes perpetrated against tenants in common area of apartment complex); *Johnston v. Harris*, 387 Mich. 569, 573–74 (1972); *Faheen By Hebron v. City Parking Corp.*, 734 S.W.2d 270, 273 (Mo.App.1987).

The fourth exception derives from the general tort principle that one who voluntarily assumes a duty thereafter has a duty to act with reasonable care. *See Restatement (Second) of Torts, supra* §§ 323, 324. Thus, landlords who gratuitously or contractually provide security have been found liable for removing the security in the face of a foreseeable criminal threat. [cc]

We hold that while landlords have no general duty to protect tenants from criminal attack, such a duty may arise when a landlord has created, or is responsible for, a known defective condition on a premises that foreseeably enhanced the risk of criminal attack. Moreover, a landlord who undertakes, either gratuitously or by contract, to provide security will thereafter have a duty to act with reasonable care. Where, however, a landlord has made no affirmative attempt to provide security, and is not responsible for a physical defect that enhances the risk of crime, we will not find such a duty. We reject liability based solely on the landlord-tenant relationship or on a doctrine of overriding foreseeability.

A finding that an approved exception applies is not dispositive of the landlord's liability for a tenant's injury. Where a landlord's duty is premised on a defective condition that has foreseeably enhanced the risk of criminal attack, the question whether the defect *660 was a proximate or legal cause of the tenant's injury remains one of fact. Moreover, where a landlord has voluntarily assumed a duty to provide some degree of security, this duty is limited by the extent of the undertaking. [c] *Rowe*, 125 Ill.2d at 218–19, 126 Ill. Dec. at 526. For example, a landlord who provides lighting for the exterior of an apartment building might be held liable for failing to insure that the lighting functioned properly, but not for failing to provide additional security measures such as patrol services or protective fencing.

The answer to the [***] question is no, subject to the pleading or proof, as appropriate, of facts supporting the approved exceptions.

Remanded.

Note 1. Revisiting the purposes of tort law—fairness, compensation, deterrence, efficiency and social justice—which of these are served (and disserved) by attaching tort liability to landlords for third-party criminal attacks suffered by their tenants?

Note 2. Whom does a blanket rule on this issue serve best? If tort liability does not attach to landlords for third-party criminal activity, what other incentives do landlords have to make their property safer for the benefit of their tenants? Do you think they are as effective as those that tort law ordinarily attempts to create? What are the effects, for tenants, of expanding the liability of landlords?

Expand On Your Understanding – Socratic Script: Walls v. Oxford Management

Question 1. What is the holding of the case?

An interactive H5P element has been excluded from this version of the text. You can view it online here: <https://saidtorts2d.lawbooks.cali.org/?p=55#h5p-48>

Question 2. Why is a jury not involved in resolving the case?

An interactive H5P element has been excluded from this version of the text. You can view it online here: <https://saidtorts2d.lawbooks.cali.org/?p=55#h5p-49>

Question 3. What tension in common law rules does the court identify in its reasoning? Another way of putting this question is that the court identifies a set of competing default rules; how does it frame those and how does it tailor its holding in light of them?

An interactive H5P element has been excluded from this version of the text. You can view it online here: <https://saidtorts2d.lawbooks.cali.org/?p=55#h5p-50>

Question 4. What does the court mean when it states that it “will not place on landlords the burden of insuring their tenants against harm from criminal attacks”?

An interactive H5P element has been excluded from this version of the text. You can view it online here: <https://saidtorts2d.lawbooks.cali.org/?p=55#h5p-51>

Question 5. What consequences might follow if courts routinely *did* find that landlords owed their tenants a general duty of care to prevent criminal attacks?

An interactive H5P element has been excluded from this version of the text. You can view it online here: <https://saidtorts2d.lawbooks.cali.org/?p=55#h5p-52>

Tarasoff v. Regents of the University of California is that rare case that many non-lawyers recognize (and may fear). In the fields of medicine, psychology and social work, the case is routinely taught because of its impact on the duties of those who become aware of credible risks to specific third parties. The case surprised many by finding there *was* a duty on the part of a therapist to warn a specific third

party who was not his client, even though that would have meant violating client confidentiality and even though he had no other relationship with that third party. His client, Prosenjit Poddar, had threatened harm to a young woman, Tatiana Tarasoff, and Poddar ultimately killed her. There is a troubling dynamic present in the case, of a mentally unstable young man who, in response to rejection by a female student, acts out his feelings in deadly violence. As you read, keep in mind what sorts of expectations the parties involved in such a scenario may have and try to imagine the impact of any alternative ruling the court could have handed down.

Tarasoff v. Regents of the University of California, Supreme Court of California (1976) (551 P.2d 334)

On October 27, 1969, Prosenjit Poddar killed Tatiana Tarasoff. Plaintiffs, Tatiana's parents, allege that two months earlier Poddar confided his intention to kill Tatiana to Dr. Lawrence Moore, a psychologist employed by the Cowell Memorial Hospital at the University of California at Berkeley. They allege that on Moore's request, the campus police briefly detained Poddar, but released him when he appeared rational. They further claim that Dr. Harvey Powelson, Moore's superior, then directed that no further action be taken to detain Poddar. No one warned plaintiffs of Tatiana's peril.

Concluding that these facts set forth causes of action against neither therapists and policemen involved, nor against the Regents of the University of California as their employer, the superior court sustained defendants' demurrers to plaintiffs' second amended complaints without leave to amend. This appeal ensued.

Plaintiffs' complaints predicate liability on... defendants' failure to warn plaintiffs of the impending danger.... Defendants, in turn, assert that they owed no duty of reasonable care to Tatiana. The most important ...consideration ... in establishing duty is foreseeability. As a general principle, a 'defendant owes a duty of care to all persons who are foreseeably endangered by his conduct, with respect to all risks which make the conduct unreasonably dangerous.' ...

Although ... under the common law, as a general rule, one person owed no duty to control the conduct of another nor to warn those endangered by such conduct, the courts have carved out an exception to this rule in cases in which the defendant stands in some special relationship to either the person whose conduct needs to be controlled or in a relationship to the foreseeable victim of that conduct. Applying this exception to the present case, we note that a relationship of defendant therapists to either Tatiana or Poddar will suffice to establish a duty of care; as explained in section 315 of the Restatement Second of Torts, a duty of care may arise from either '(a) a special relation ... between the actor and the third person which imposes a duty upon the actor to control the third person's conduct, or (b) a special relation ... between the actor and the other which gives to the other a right of protection.'

Although plaintiffs' pleadings assert no special relation between Tatiana and defendant therapists, they establish as between Poddar and defendant therapists the special relation that arises between a patient and his doctor or psychotherapist. Such a relationship may support affirmative duties for the benefit of third persons. Thus, for example, a hospital must exercise reasonable care to control the behavior of a

patient which may endanger other persons. A doctor must also warn a patient if the patient's condition or medication renders certain conduct, such as driving a car, dangerous to others. ...

Defendants contend, however, that imposition of a duty to exercise reasonable care to protect third persons is unworkable because therapists cannot accurately predict whether or not a patient will resort to violence. [***]

We recognize the difficulty that a therapist encounters in attempting to forecast whether a patient presents a serious danger of violence. Obviously we do not require that the therapist, in making that determination, render a perfect performance; the therapist need only exercise 'that reasonable degree of skill, knowledge, and care ordinarily possessed and exercised by members of (that professional specialty) under similar circumstances.' ...In the instant case, however, the pleadings do not raise any question as to failure of defendant therapists to predict that Poddar presented a serious danger of violence. On the contrary, the present complaints allege that defendant therapists did in fact predict that Poddar would kill, but were negligent in failing to warn. ...Weighing the uncertain and conjectural character of the alleged damage done the patient by such a warning against the peril to the victim's life, we conclude that professional inaccuracy in predicting violence cannot negate the therapist's duty to protect the threatened victim.

The risk that unnecessary warnings may be given is a reasonable price to pay for the lives of possible victims that may be saved. We would hesitate to hold that the therapist who is aware that his patient expects to attempt to assassinate the President of the United States would not be obligated to warn the authorities because the therapist cannot predict with accuracy that his patient will commit the crime.

...

The revelation of a communication under the above circumstances is not a breach of trust or a violation of professional ethics; as stated in the Principles of Medical Ethics of the American Medical Association (1957), section 9: "A physician may not reveal the confidence entrusted to him in the course of medical attendance ... [u]nless he is required to do so by law or unless it becomes necessary in order to protect the welfare of the individual or of the community." We conclude that the public policy favoring protection of the confidential character of patient-psychotherapist communications must yield to the extent to which disclosure is essential to avert danger to others. The protective privilege ends where the public peril begins. [***]

The judgment of the superior court in favor of defendants ... is reversed, and the cause remanded for further proceedings consistent with the views expressed herein.

Note 1. *Tarasoff* provides the rule that "[t]he protective privilege ends where the public peril begins." Do you think it is clear to therapists when that public peril begins? What sorts of methods, or evidence, do you imagine being helpful to that determination?

Note 2. What are the risks of placing the determination of "public peril" with a therapist? If a therapist *did* warn the third party and it caused *worse* harm, perhaps because the patient learned about it, or for other reasons, would the *Tarasoff* duty have been satisfied or breached? If a therapist were sufficiently concerned to warn a third party, should the duty also extend to warning the police? What about to family members of the therapist's clients? Are there implications for the no-duty doctrine of receiving *Tarasoff* warnings from therapists?

Note 3. The *Tarasoff* rule has been limited in some cases (to specific or “identifiable” victims) and in some states, it has expressly been rejected (with such states reaffirming on the grounds of the no duty/special relationship rules that therapists have no duty to third-party victims). Before this case, the general rule was clear: there was no duty to warn arising out of the therapeutic relationship. On the contrary, there were professional norms and legal obligations of confidentiality to the patient. As discussed in the introduction to this section, the court uses the term “affirmative” to refer to duties against the backdrop of that “no-duty” common law default: “Such a relationship may support *affirmative duties* for the benefit of third persons.” It does so partly to announce a change in the law. Indeed, despite finding that there was no special relationship here that would ordinarily “ground” (or give rise to) a duty, the court finds one on the basis of foreseeability. “The most important ... consideration ... in establishing duty is foreseeability”; “a ‘defendant owes a duty of care to all persons who are foreseeably endangered by his conduct, with respect to all risks which make the conduct unreasonably dangerous.’”

Tarasoff presents the unusual case in which a court makes a sharp change on the basis of particular facts and policy rationales, and then subsequent courts, legislators, and the professional or other entities affected by the ruling must make decisions to adopt, reject, respond in some other fashion or ignore the case. It is rare that a major ruling and a sudden significant change will be completely ignored, however. What changes would you recommend in a jurisdiction that had not yet adopted *Tarasoff*, and why?

One of the most famous cases you will read in law school, *Palsgraf v. Long Island Railroad*, concerns the scope of duty owed to an injured person whose injury the defendant might not anticipate or be able to foresee. It is often taught as a case about proximate cause—which is how the dissent frames the issue—but in fact the opinion concerns the scope of responsibility to an unforeseeable victim and the holding is framed in terms of duty.

Palsgraf v. Long Island R. Co., Court of Appeals of New York (1928) (248 N.Y. 339) Justice Cardozo

Plaintiff was standing on a platform of defendant’s railroad after buying a ticket to go to Rockaway Beach. A train stopped at the station, bound for another place. Two men ran forward to catch it. One of the men reached the platform of the car without mishap, though the train was already moving. The other man, carrying a package, jumped aboard the car, but seemed unsteady as if about to fall. A guard on the car, who had held the door open, reached forward to help *341 him in, and another guard on the platform pushed him from behind. In this act, the package was dislodged, and fell upon the rails. It was a package of small size, about fifteen inches long, and was covered by a newspaper. In fact it contained fireworks, but there was nothing in its appearance to give notice of its contents. The fireworks when they fell exploded. The shock of the explosion threw down some scales at the other end of the platform many feet away. The scales struck the plaintiff, causing injuries for which she sues.

The conduct of the defendant’s guard, if a wrong in its relation to the holder of the package, was not a wrong in its relation to the plaintiff, standing far away. Relatively to her it was not negligence at all. Nothing in the situation gave notice that the falling package had in it the potency of peril to persons thus removed. Negligence is not actionable unless it involves the invasion of a legally protected

interest, the violation of a right. 'Proof of negligence in the air, so to speak, will not do.' Pollock, Torts (11th Ed.) p. 455; *Martin v. Herzog*, 228 N. Y. 164, 170, Cf. Salmond, Torts (6th Ed.) p. 24. 'Negligence is the absence of care, according to the circumstances.' [c]

The plaintiff, as she stood upon the platform of the station, might claim to be protected against intentional invasion of her bodily security. Such invasion is not charged. She might claim to be protected against unintentional invasion by conduct involving in the thought of reasonable men an unreasonable hazard that such invasion would ensue. These, from the point of view of the law, were the bounds of her immunity, with perhaps some rare exceptions, survivals for the most part of ancient forms of liability, where conduct is held to be at the peril of the actor. *342 If no hazard was apparent to the eye of ordinary vigilance, an act innocent and harmless, at least to outward seeming, with reference to her, did not take to itself the quality of a tort because it happened to be a wrong, though apparently not one involving the risk of bodily insecurity, with reference to some one else. 'In every instance, before negligence can be predicated of a given act, back of the act must be sought and found a duty to the individual complaining, the observance of which would have averted or avoided the injury.' [cc] The plaintiff sues in her own right for a wrong personal to her, and not as the vicarious beneficiary of a breach of duty to another.

A different conclusion will involve us, and swiftly too, in a maze of contradictions. A guard stumbles over a package which has been left upon a platform. It seems to be a bundle of newspapers. It turns out to be a can of dynamite. To the eye of ordinary vigilance, the bundle is abandoned waste, which may be kicked or trod on with impunity. Is a passenger at the other end of the platform protected by the law against the unsuspected hazard concealed beneath the waste? If not, is the result to be any different, so far as the distant passenger is concerned, when the guard stumbles over a valise *343 which a truckman or a porter has left upon the walk? The passenger far away, if the victim of a wrong at all, has a cause of action, not derivative, but original and primary. His claim to be protected against invasion of his bodily security is neither greater nor less because the act resulting in the invasion is a wrong to another far removed.

In this case, the rights that are said to have been violated, are not even of the same order. The man was not injured in his person nor even put in danger. The purpose of the act, as well as its effect, was to make his person safe. It there was a wrong to him at all, which may very well be doubted it was a wrong to a property interest only, the safety of his package.

Out of this wrong to property, which threatened injury to nothing else, there has passed, we are told, to the plaintiff by derivation or succession a right of action for the invasion of an interest of another order, the right to bodily security. The diversity of interests emphasizes the futility of the effort to build the plaintiff's right upon the basis of a wrong to someone else. The gain is one of emphasis, for a like result would follow if the interests were the same. Even then, the orbit of the danger as disclosed to the eye of reasonable vigilance would be the orbit of the duty. One who jostles one's neighbor in a crowd does not invade the rights of others standing at the outer fringe when the unintended contact casts a bomb upon the ground. The wrongdoer as to them is the man who carries the bomb, not the one who explodes it without suspicion of the danger. Life will have to be made over, and human nature transformed, before prevision so extravagant can be accepted as the norm of conduct, the customary standard to which behavior must conform.

The argument for the plaintiff is built upon the shifting meanings of such words as ‘wrong’ and ‘wrongful,’ and shares their instability. What the plaintiff must *344 show is ‘a wrong’ to herself; i.e., a violation of her own right, and not merely a wrong to someone else, nor conduct ‘wrongful’ because unsocial, but not ‘a wrong’ to anyone. We are told that one who drives at reckless speed through a crowded city street is guilty of a negligent act and therefore of a wrongful one, irrespective of the consequences. Negligent the act is, and wrongful in the sense that it is unsocial, but wrongful and unsocial in relation to other travelers, only because the eye of vigilance perceives the risk of damage. If the same act were to be committed on a speedway or a race course, it would lose its wrongful quality. The risk reasonably to be perceived defines the duty to be obeyed, and risk imports relation; it is risk to another or to others within the range of apprehension. [cc]

This does not mean, of course, that one who launches a destructive force is always relieved of liability, if the force, though known to be destructive, pursues an unexpected path. ‘It was not necessary that the defendant should have had notice of the particular method in which an accident would occur, if the possibility of an accident was clear to the ordinarily prudent eye.’ [Citations omitted] Some acts, such as shooting are so imminently dangerous to any one who may come within reach of the missile however unexpectedly, as to impose a duty of prevision not far from that of an insurer. Even to-day, and much oftener in earlier stages of the law, one acts sometimes at one’s peril. [cc] Under this head, it may be, fall certain cases of what is known as transferred intent, an act willfully dangerous to A resulting by misadventure in injury to B. *Talmage v. Smith*, 101 Mich. 370, 374 *345 These cases aside, wrong is defined in terms of the natural or probable, at least when unintentional. *Parrot v. Wells-Fargo Co. (The Nitro-Glycerine Case)* 15 Wall. 524, 21 L. Ed. 206. The range of reasonable apprehension is at times a question for the court, and at times, if varying inferences are possible, a question for the jury.

Here, by concession, there was nothing in the situation to suggest to the most cautious mind that the parcel wrapped in newspaper would spread wreckage through the station. If the guard had thrown it down knowingly and willfully, he would not have threatened the plaintiff’s safety, so far as appearances could warn him. His conduct would not have involved, even then, an unreasonable probability of invasion of her bodily security. Liability can be no greater where the act is inadvertent.

Negligence, like risk, is thus a term of relation. Negligence in the abstract, apart from things related, is surely not a tort, if indeed it is understandable at all. [c] Negligence is not a tort unless it results in the commission of a wrong, and the commission of a wrong imports the violation of a right, in this case, we are told, the right to be protected against interference with one’s bodily security. But bodily security is protected, not against all forms of interference or aggression, but only against some. One who seeks redress at law does not make out a cause of action by showing without more that there has been damage to his person. If the harm was not willful, he must show that the act as to him had possibilities of danger so many and apparent as to entitle him to be protected against the doing of it though the harm was unintended. [***] Confirmation of this view will be found in the history and development of the action on the case.

Negligence as a basis of civil liability was unknown to mediaeval law. 8 Holdsworth, *History of English Law*, p. 449; Street, *Foundations of Legal Liability*, vol. 1, *346 pp. 189, 190. For damage to the person, the sole remedy was trespass, and trespass did not lie in the absence of aggression, and that direct and personal. [***] Liability for other damage, as where a servant without orders from the master does or omits something to the damage of another, is a plant of later growth. [cc] When it emerged out of the legal soil, it was thought of as a variant of trespass, an offshoot of the parent stock. This appears

in the form of action, which was known as trespass on the case. [cc] The victim does not sue derivatively, or by right of subrogation, to vindicate an interest invaded in the person of another. Thus to view his cause of action is to ignore the fundamental difference between tort and crime. Holland, *Jurisprudence* (12th Ed.) p. 328. He sues for breach of a duty owing to himself.

The law of causation, remote or proximate, is thus foreign to the case before us. The question of liability is always anterior to the question of the measure of the consequences that go with liability. If there is no tort to be redressed, there is no occasion to consider what damage might be recovered if there were a finding of a tort. We may assume, without deciding, that negligence, not at large or in the abstract, but in relation to the plaintiff, would entail liability for any and all consequences, however novel or extraordinary [cc] There is room for *347 argument that a distinction is to be drawn according to the diversity of interests invaded by the act, as where conduct negligent in that it threatens an insignificant invasion of an interest in property results in an unforeseeable invasion of an interest of another order, as, e. g., one of bodily security. Perhaps other distinctions may be necessary. We do not go into the question now. The consequences to be followed must first be rooted in a wrong.

The judgment of the Appellate Division and that of the Trial Term should be reversed, and the complaint dismissed, with costs in all courts.

ANDREWS, J. (dissenting).

Assisting a passenger to board a train, the defendant's servant negligently knocked a package from his arms. It fell between the platform and the cars. Of its contents the servant knew and could know nothing. A violent explosion followed. The concussion broke some scales standing a considerable distance away. In falling, they injured the plaintiff, an intending passenger.

Upon these facts, may she recover the damages she has suffered in an action brought against the master? The result we shall reach depends upon our theory as to the nature of negligence. Is it a relative concept—the breach of some duty owing to a particular person or to particular persons? Or, where there is an act which unreasonably threatens the safety of others, is the doer liable for all its proximate consequences, even where they result in injury to one who would generally be thought to be outside the radius of danger? This is not a mere dispute as to words. We might not believe that to the average mind the dropping of the bundle would seem to involve the probability of harm to the plaintiff standing many feet away whatever might be the case as to the owner or to one so near as to be likely to be struck by its fall. If, however, we adopt the second hypothesis, *348 we have to inquire only as to the relation between cause and effect. We deal in terms of proximate cause, not of negligence.

Negligence may be defined roughly as an act or omission which unreasonably does or may affect the rights of others, or which unreasonably fails to protect one's self from the dangers resulting from such acts. Here I confine myself to the first branch of the definition. Nor do I comment on the word 'unreasonable.' For present purposes it sufficiently describes that average of conduct that society requires of its members.

There must be both the act or the omission, and the right. It is the act itself, not the intent of the actor, that is important. [c] In criminal law both the intent and the result are to be considered. Intent again is material in tort actions, where punitive damages are sought, dependent on actual malice—not one merely reckless conduct. But here neither insanity nor infancy lessens responsibility. [c] As has been said, except in cases of contributory negligence, there must be rights which are or may be affected.

Often though injury has occurred, no rights of him who suffers have been touched. A licensee or trespasser upon my land has no claim to affirmative care on my part that the land be made safe. [c] Where a railroad is required to fence its tracks against cattle, no man's rights are injured should he wander upon the road because such fence is absent. [c] An unborn child may not demand immunity from personal harm. [c]

But we are told that 'there is no negligence unless there is in the particular case a legal duty to take care, and this duty must be one which is owed to the plaintiff *349 himself and not merely to others.' Salmond Torts (6th Ed.) 24. This I think too narrow a conception. Where there is the unreasonable act, and some right that may be affected there is negligence whether damage does or does not result. That is immaterial. Should we drive down Broadway at a reckless speed, we are negligent whether we strike an approaching car or miss it by an inch. The act itself is wrongful. It is a wrong not only to those who happen to be within the radius of danger, but to all who might have been there—a wrong to the public at large. Such is the language of the street. Such the language of the courts when speaking of contributory negligence. Such again and again their language in speaking of the duty of some defendant and discussing proximate cause in cases where such a discussion is wholly irrelevant on any other theory. [c] As was said by Mr. Justice Holmes many years ago:

'The measure of the defendant's duty in determining whether a wrong has been committed is one thing, the measure of liability when a wrong has been committed is another,' Spade v. Lynn & B. R. Co., 172 Mass. 488, 491, (43 L. R. A. 832, 70 Am. St. Rep. 298).

Due care is a duty imposed on each one of us to protect society from unnecessary danger, not to protect A, B, or C alone. It may well be that there is no such thing as negligence in the abstract. 'Proof of negligence in the air, so to speak, will not do.' In an empty world negligence would not exist. It does involve a relationship between man and his fellows, but not merely a relationship between man and those whom he might reasonably expect his act would injure; rather, a relationship between him and those whom he does in fact injure. If his act has a tendency to harm someone, it harms him a mile away as surely as it does those on the scene.

We now permit children to recover for the negligent killing of the father. It was never prevented on the theory that no duty was owing to them. A husband may be compensated for *350 the loss of his wife's services. To say that the wrongdoer was negligent as to the husband as well as to the wife is merely an attempt to fit facts to theory. An insurance company paying a fire loss recovers its payment of the negligent incendiary. We speak of subrogation—of suing in the right of the insured. Behind the cloud of words is the fact they hide, that the act, wrongful as to the insured, has also injured the company. Even if it be true that the fault of father, wife, or insured will prevent recovery, it is because we consider the original negligence, not the proximate cause of the injury. Pollock, Torts (12th Ed.) 463.

In the well-known Polemis Case, [1921] 3 K. B. 560, Scrutton, L. J., said that the dropping of a plank was negligent, for it might injure 'workman or cargo or ship.' Because of either possibility, the owner of the vessel was to be made good for his loss. The act being wrongful, the doer was liable for its proximate results. Criticized and explained as this statement may have been, I think it states the law as it should be and as it is. [***]

The proposition is this: Everyone owes to the world at large the duty of refraining from those acts that may unreasonably threaten the safety of others. Such an act occurs. Not only is he wronged to whom

harm, might reasonably be expected to result, but he also who is in fact injured, even if he be outside what would generally be thought the danger zone. There needs be duty due the one complaining, but this is not a duty to a particular individual because as to him harm might be expected. Harm to someone being the natural result of the act, not only that one alone, but all those in fact injured may complain. We have never, I think, held otherwise. Indeed in the Di Caprio Case we said that a breach of a *351 general ordinance defining the degree of care to be exercised in one's calling is evidence of negligence as to everyone. We did not limit this statement to those who might be expected to be exposed to danger. Unreasonable risk being taken, its consequences are not confined to those who might probably be hurt.

If this be so, we do not have a plaintiff suing by 'derivation or succession.' Her action is original and primary. Her claim is for a breach of duty to herself—not that she is subrogated to any right of action of the owner of the parcel or of a passenger standing at the scene of the explosion.

The right to recover damages rests on additional considerations. The plaintiff's rights must be injured, and this injury must be caused by the negligence. We build a dam, but are negligent as to its foundations. Breaking, it injures property downstream. We are not liable if all this happened because of some reason other than the insecure foundation. But, when injuries do result from out unlawful act, we are liable for the consequences. It does not matter that they are unusual, unexpected, unforeseen, and unforeseeable. But there is one limitation. The damages must be so connected with the negligence that the latter may be said to be the proximate cause of the former. These two words have never been given an inclusive definition. What is a cause in a legal sense, still more what is a proximate cause, depend in each case upon many considerations, as does the existence of negligence itself. Any philosophical doctrine of causation does not help us. A boy throws a stone into a pond. The ripples spread. The water level rises. The history of that pond is altered to all eternity. It will be altered by other causes also. Yet it will be forever the resultant of all causes combined. Each one will have an influence. How great only omniscience can say. You may speak of a chain, or, if you please, a net. An analogy is of little aid. *352 Each cause brings about future events. Without each the future would not be the same. Each is proximate in the sense it is essential. But that is not what we mean by the word. Nor on the other hand do we mean sole cause. There is no such thing.

Should analogy be thought helpful, however, I prefer that of a stream. The spring, starting on its journey, is joined by tributary after tributary. The river, reaching the ocean, comes from a hundred sources. No man may say whence any drop of water is derived. Yet for a time distinction may be possible. Into the clear creek, brown swamp water flows from the left. Later, from the right comes water stained by its clay bed. The three may remain for a space, sharply divided. But at last inevitably no trace of separation remains. They are so commingled that all distinction is lost. As we have said, we cannot trace the effect of an act to the end, if end there is. Again, however, we may trace it part of the way. A murder at Sarajevo may be the necessary antecedent to an assassination in London twenty years hence. An overturned lantern may burn all Chicago. We may follow the fire from the shed to the last building. We rightly say the fire started by the lantern caused its destruction.

A cause, but not the proximate cause. What we do mean by the word 'proximate' is that, because of convenience, of public policy, of a rough sense of justice, the law arbitrarily declines to trace a series of events beyond a certain point. This is not logic. It is practical politics. Take our rule as to fires. Sparks from my burning haystack set on fire my house and my neighbor's. I may recover from a negligent railroad He may not. Yet the wrongful act as directly harmed the one as the other. We may

regret that the line was drawn just where it was, but drawn somewhere it had to be. We said the act of the railroad was not the proximate cause of our neighbor's fire. Cause it surely was. The words we used were *353 simply indicative of our notions of public policy. Other courts think differently. But somewhere they reach the point where they cannot say the stream comes from any one source.

Take the illustration given in an unpublished manuscript by a distinguished and helpful writer on the law of torts. A chauffeur negligently collides with another car which is filled with dynamite, although he could not know it. An explosion follows. A, walking on the sidewalk nearby, is killed. B, sitting in a window of a building opposite, is cut by flying glass. C, likewise sitting in a window a block away, is similarly injured. And a further illustration: A nursemaid, ten blocks away, startled by the noise, involuntarily drops a baby from her arms to the walk. We are told that C may not recover while A may. As to B it is a question for court or jury. We will all agree that the baby might not. Because, we are again told, the chauffeur had no reason to believe his conduct involved any risk of injuring either C or the baby. As to them he was not negligent. But the chauffeur, being negligent in risking the collision, his belief that the scope of the harm he might do would be limited is immaterial. His act unreasonably jeopardized the safety of any one who might be affected by it. C's injury and that of the baby were directly traceable to the collision. Without that, the injury would not have happened. C had the right to sit in his office, secure from such dangers. The baby was entitled to use the sidewalk with reasonable safety.

The true theory is, it seems to me, that the injury to C, if in truth he is to be denied recovery, and the injury to the baby, is that their several injuries were not the proximate result of the negligence. And here not what the chauffeur had reason to believe would be the result of his conduct, but what the prudent would foresee, may have a bearing—may have some bearing, for the problem *354 of proximate cause is not to be solved by any one consideration. It is all a question of expediency. There are no fixed rules to govern our judgment. There are simply matters of which we may take account. We have in a somewhat different connection spoken of 'the stream of events.' We have asked whether that stream was deflected—whether it was forced into new and unexpected channels. [***] This is rather rhetoric than law. There is in truth little to guide us other than common sense.

There are some hints that may help us. The proximate cause, involved as it may be with many other causes, must be, at the least, something without which the event would not happen. The court must ask itself whether there was a natural and continuous sequence between cause and effect. Was the one a substantial factor in producing the other? Was there a direct connection between them, without too many intervening causes? Is the effect of cause on result not too attenuated? Is the cause likely, in the usual judgment of mankind, to produce the result? Or, by the exercise of prudent foresight, could the result be foreseen? Is the result too remote from the cause, and here we consider remoteness in time and space. [c] Clearly we must so consider, for the greater the distance either in time or space, the more surely do other causes intervene to affect the result. When a lantern is overturned, the firing of a shed is a fairly direct consequence. Many things contribute to the spread of the conflagration—the force of the wind, the direction and width of streets, the character of intervening structures, other factors. We draw an uncertain and wavering line, but draw it we must as best we can. Once again, it is all a question of fair judgment, always *355 keeping in mind the fact that we endeavor to make a rule in each case that will be practical and in keeping with the general understanding of mankind.

Here another question must be answered. In the case supposed, it is said, and said correctly, that the chauffeur is liable for the direct effect of the explosion, although he had no reason to suppose it would

follow a collision. ‘The fact that the injury occurred in a different manner than that which might have been expected does not prevent the chauffeur’s negligence from being in law the cause of the injury.’ But the natural results of a negligent act—the results which a prudent man would or should foresee—do have a bearing upon the decision as to proximate cause. We have said so repeatedly. What should be foreseen? No human foresight would suggest that a collision itself might injure one a block away. On the contrary, given an explosion, such a possibility might be reasonably expected. I think the direct connection, the foresight of which the courts speak, assumes prevision of the explosion, for the immediate results of which, at least, the chauffeur is responsible.

It may be said this is unjust. Why? In fairness he should make good every injury flowing from his negligence. Not because of tenderness toward him we say he need not answer for all that follows his wrong. We look back to the catastrophe, the fire kindled by the spark, or the explosion. We trace the consequences, not indefinitely, but to a certain point. And to aid us in fixing that point we ask what might ordinarily be expected to follow the fire or the explosion.

This last suggestion is the factor which must determine the case before us. The act upon which defendant’s liability rests is knocking an apparently harmless package onto the platform. The act was negligent. For its proximate consequences the defendant is liable. If its contents were broken, to the owner; if it fell upon and crushed a passenger’s foot, then to him; if it exploded *356 and injured one in the immediate vicinity, to him also as to A in the illustration. Mrs. Palsgraf was standing some distance away. How far cannot be told from the record—apparently 25 or 30 feet, perhaps less. Except for the explosion, she would not have been injured. We are told by the appellant in his brief, ‘It cannot be denied that the explosion was the direct cause of the plaintiff’s injuries.’ So it was a substantial factor in producing the result—there was here a natural and continuous sequence—direct connection. The only intervening cause was that, instead of blowing her to the ground, the concussion smashed the weighing machine which in turn fell upon her. There was no remoteness in time, little in space. And surely, given such an explosion as here, it needed no great foresight to predict that the natural result would be to injure one on the platform at no greater distance from its scene than was the plaintiff. Just how no one might be able to predict. Whether by flying fragments, by broken glass, by wreckage of machines or structures no one could say. But injury in some form was most probable.

Under these circumstances I cannot say as a matter of law that the plaintiff’s injuries were not the proximate result of the negligence. That is all we have before us. The court refused to so charge. No request was made to submit the matter to the jury as a question of fact, even would that have been proper upon the record before us.

The judgment appealed from should be affirmed, with costs.

Note 1. You know it’s a famous case when there’s a Lego dramatization. You might appreciate this 5:24 minute Lego-figure parody and recreation of the facts and trial of *Palsgraf* (but beware that it takes liberties such as including an anachronistic TSA interview and televisual exhibit in the courtroom). It’s available [here](https://www.youtube.com/watch?v=mDEbTudkjhc) (full link: <https://www.youtube.com/watch?v=mDEbTudkjhc>)

Note 2. *Palsgraf* may be famous because of the oddly vivid facts, the socioeconomic context, and the elevated language and reasoning of the majority and dissenting opinions by Justice Cardozo and Justice Andrews, respectively. These two justices remain extremely well-respected for their analytic craft, especially Justice Cardozo, who would go on to become one of the most influential justices of the century (and a renowned expert on tort law). But it was also an important opinion because it featured

a dispute over where in the negligence action the scope of the tort was to be defined—at the duty stage, as a matter of law for the judge, or at the later proximate cause stage, as a question of fact for the jury. The two justices are both trying to answer the same normative question: *Should* the court hold the defendant liable to this plaintiff? Given that, why might it matter whether a case like *Palsgraf* is decided by a judge versus a jury?

Note 3. If “foreseeability” is the driving consideration behind duty (and plays a role in many analyses of proximate cause), it ought to be a principle that can be conceptualized in terms of tort law’s purposes. How well does it serve compensation, deterrence, efficiency, fairness and social justice? What sorts of consequences do you imagine an emphasis on foreseeability could produce in the real world in terms of parties’ behavior and choices?

Check Your Understanding (3-1)

Question 1. Complete the sentence with the most descriptively accurate answer: In *Palsgraf*, Justice Cardozo overturned the jury verdict below, reversed and rejected Mrs. Palsgraf’s appeal because ____:

An interactive H5P element has been excluded from this version of the text. You can view it online here: <https://saidtorts2d.lawbooks.cali.org/?p=55#h5p-53>

Question 2. Doctrinal Synthesis. Learning in law school is cumulative and reviewing earlier doctrines regularly helps you both to recall and refine them. The following questions ask you to synthesize learning from earlier cases you’ve covered. For each one, answer whether the doctrine might be relevant on the facts of *Palsgraf*.

Common carriers face heightened duties towards their passengers

An interactive H5P element has been excluded from this version of the text. You can view it online here: <https://saidtorts2d.lawbooks.cali.org/?p=55#h5p-54>

Causa causans

An interactive H5P element has been excluded from this version of the text. You can view it online here: <https://saidtorts2d.lawbooks.cali.org/?p=55#h5p-55>

Strict liability

An interactive H5P element has been excluded from this version of the text. You can view it online here: <https://saidtorts2d.lawbooks.cali.org/?p=55#h5p-56>

Apparent consent

An interactive H5P element has been excluded from this version of the text. You can view it online here: <https://saidtorts2d.lawbooks.cali.org/?p=55#h5p-57>

Transferred intent

An interactive H5P element has been excluded from this version of the text. You can view it online here: <https://saidtorts2d.lawbooks.cali.org/?p=55#h5p-58>

Vicarious liability

An interactive H5P element has been excluded from this version of the text. You can view it online here: <https://saidtorts2d.lawbooks.cali.org/?p=55#h5p-59>

Duties Determined by Relationship or Undertaking

Harper v. Herman, Supreme Court of Minnesota (1993) (499 N.W.2d 472)

This case arises upon a reversal by the court of appeals of summary judgment in favor of the defendant. The court of appeals held that defendant, the owner and operator of a private boat on Lake Minnetonka, had a duty to warn plaintiff, a guest on the boat, that water surrounding the boat was too shallow for diving. We reverse and reinstate judgment in favor of defendant.

The facts are undisputed for the purpose of this appeal. On Sunday, August 9, 1986, Jeffrey Harper (“Harper”) was one of four guests on Theodor Herman’s (“Herman”) 26-foot boat, sailing on Lake Minnetonka. Harper was invited on the boat outing by Cindy Alberg Palmer, another guest on Herman’s boat. Herman and Harper did not know each other prior to this boat outing. At the time Herman was 64 years old, and Harper was 20 years old. Herman was an experienced boat owner having spent hundreds of hours operating boats on Lake Minnetonka similar to the one involved in this action. As owner of the boat, Herman considered himself to be in charge of the boat and his passengers. Harper had some experience swimming in lakes and rivers, but had no formal training in diving.

After a few hours of boating, the group decided to go swimming and, at Herman’s suggestion, went to Big Island, a popular recreation spot. Herman was familiar with Big Island, and he was aware that the water remains shallow for a good distance away from its shore. Harper had been to Big Island on one previous occasion. Herman positioned the boat somewhere between 100 to 200 yards from the island with the bow facing away from the island in an area shallow enough for his guests to use the boat

ladder to enter the water, but still deep enough so they could swim.⁷¹ The bottom of the lake was not visible from the *474 boat. After positioning the boat Herman proceeded to set the anchor and lower the boat's ladder which was at its stern.

While Herman was lowering the ladder, Harper asked him if he was "going in." When Herman responded yes, Harper, without warning, stepped onto the side of the middle of the boat and dove into approximately two or three feet of water. As a result of the dive, Harper struck the bottom of the lake, severed his spinal cord, and was rendered a C6 quadriplegic.

Harper then brought suit, alleging that Herman owed him a duty of care to warn him that the water was too shallow for diving. On October 23, 1991, the trial court granted Herman's motion for summary judgment, ruling that the law does not impose such a duty. In reversing the trial court, the court of appeals concluded that Herman voluntarily assumed a duty to exercise reasonable care when he allowed Harper onto his boat, and that the duty of care included warning Harper not to dive because he knew that the water was "dangerously shallow." *Harper v. Herman*, 487 N.W.2d 908, 910 (Minn.App.1992). [***]

Harper alleges that Herman owed him a duty to warn of the shallowness of the water because he was an inexperienced swimmer and diver, whereas Herman was a veteran boater. Under those circumstances, Harper argues, Herman should have realized that Harper needed his protection.

We have previously stated that an affirmative duty to act only arises when a special relationship exists between the parties. "The fact that an actor realizes or should realize that action on his part is necessary for another's aid or protection does not of itself impose upon him a duty to take such action * * * unless a special relationship exists * * * between the actor and the other which gives the other the right to protection." [c] Accepting, *arguendo*, that Herman should have realized that Harper needed protection, Harper must still prove that a special relationship existed between them that placed an affirmative duty to act on the part of Herman.

Harper argues that a special relationship requiring Herman to act for his protection was created when Herman, as a social host, allowed an inexperienced diver on his boat. Generally, a special relationship giving rise to a duty to warn is only found on the part of common carriers, innkeepers, possessors of land who hold it open to the public, and persons who have custody of another person under circumstances in which that other person is deprived of normal opportunities of self-protection. Restatement (Second) of Torts § 314A (1965). Under this rule, a special relationship could be found to exist between the parties only if Herman had custody of Harper under circumstances in which Harper was deprived of normal opportunities to protect himself.⁷² These elements are not present here.

⁷¹ Herman disputes that the boat was this far from shore, but for purposes of this appeal stipulates to Harper's allegation.

⁷² Prosser describes a circumstance in which one party would be liable in negligence because another party was deprived of normal opportunities for self-protection as occurring when the plaintiff is typically in some respect particularly vulnerable and dependent upon the defendant who, correspondingly, holds considerable power over the plaintiff's welfare. In addition, such relations have often involved some existing or potential economic advantage to the defendant. Fairness in such cases thus may require the defendant to use his power to help the plaintiff, based upon the plaintiff's expectation of protection, which itself may be based upon the defendant's expectation of financial gain. W. Page Keeton et al., *Prosser and Keeton on the Laws of Torts* § 56, at 374 (5th ed. 1984).

The record before this court does not establish that Harper was either particularly vulnerable or that he lacked the ability to protect himself. Further, the record does not establish that Herman held considerable power over Harper's welfare, or that Herman was receiving a financial gain by hosting Harper on his boat. Finally, there is nothing in the record which would suggest that Harper expected any protection *475 from Herman; indeed, no such allegation has been made.

The court of appeals found that Herman owed Harper a duty to warn him of the shallowness of the water because Herman knew that it was "dangerously shallow." We have previously stated that "[a]ctual knowledge of a dangerous condition tends to impose a special duty to do something about that condition." [***] However, superior knowledge of a dangerous condition by itself, in the absence of a duty to provide protection, is insufficient to establish liability in negligence. Thus, Herman's knowledge that the water was "dangerously shallow" without more does not create liability. [***] Harper was not deprived of opportunities to protect himself, and Herman was not expected to provide protection.

"There are many dangers, such as those of fire and water, * * * which under ordinary conditions may reasonably be expected to be fully understood and appreciated by any child * * *." Restatement (Second) of Torts § 339 cmt. j (1965). If a child is expected to understand the inherent dangers of water, so should a 20-year-old adult. Harper had no reasonable expectation to look to Herman for protection, and we hold that Herman had no duty to warn Harper that the water was shallow.

Reversed and judgment in favor of defendant reinstated.

Note 1. Does the court's ruling rest primarily on the plaintiff's expectations and capacity or the defendant's obligations? To what extent can those be uncoupled? Should it matter whether the boat's owner invited the guest directly (as he did not, in this case)?

Note 2. What facts would you add if you were seeking to convert this fact pattern into one in which Herman *did* owe Harper a duty on the basis of a special relationship?

Sidwell v. McVay, Supreme Court of Oklahoma (1955) (282 P.2d 756)

Tony Wayne Sidwell, a sixteen year old boy, as plaintiff brought this action by and through his mother and next friend, Ava Jane Sidwell, against W. F. Peterson III and Mickey McVay, two other boys about the same age, and against Ralph H. McVay and Myra E. McVay, the parents of the latter, all as defendants to recover damages for personal injuries resulting from a fireworks explosion. The parties will be referred to as they appeared in the trial court.

The question here presented is whether or not the trial court was correct in sustaining demurrers to plaintiff's evidence and dismissing the action. On the morning of July 4, 1952 at about 9:00 o'clock, the *758 defendant Mickey McVay drove by the home of plaintiff in the McVay family automobile. The two boys then drove to the McVay home where they got with the Peterson boy. For several years the three had been close school chums. They then drove to a fireworks retail sales stand where they pooled their money and bought a gross of firecrackers known as 'cherry bombs.' They returned to the McVay home where, in the breakfast room thereof and with kitchen knives, they opened about sixty

or seventy of the firecrackers and removed the gunpowder totaling about one half teacupful. From the garage or shed, they got a short piece of metal pipe with a cap screwed on one end. They used a hammer and punch to make a small hole in the middle of the pipe, in which to insert the fuse. They poured the powder into the pipe and stuffed pieces of paper in the open end. Unable to locate another cap for the pipe, the plaintiff laid the pipe on the concrete floor or driveway of the garage and began trying to beat the open end of the pipe together with a hammer. The other two boys were frightened and moved back to a safe distance. After plaintiff had hammered on the pipe for several minutes, the contraption exploded blowing off his left hand.

During the time the boys were removing the powder from the ‘cherry bombs,’ both Mr. and Mrs. McVay came through the kitchen several times, the latter admonishing them about making a mess in the breakfast room. While the plaintiff was hammering on the pipe, Mr. McVay came out of the house and got into his car. He noticed what the boys were doing and told them to get back away from the shed or they would burn it up. About a year previously the boys had made two similar bombs from aluminum pipe and Mr. McVay had driven them to a lake near the city limits to shoot them. At about that same previous time, the plaintiff and his younger brother and possibly the McVay boy had constructed a similar bomb and had exploded it outside the city limits.

[***] [On appeal, plaintiff’s] position is:

‘It was the duty of the defendants as the owners and operators of the premises to either take the dangerous ingredients away from the plaintiff, or to require him to get off of the premises before going ahead with the assembly of their various materials into the dangerous product, or, to warn plaintiff of the danger connected with what he was doing.’

With this contention, we do not agree. [***] Here the plaintiff was not attracted to the McVay home nor was he injured by any condition thereon. He was injured as a result of his own acts upon the dangerous instrumentality, the gunpowder, which the plaintiff himself had assisted in bringing onto the premises. The plaintiff was a sixteen year old boy with an alert mind and a past experience with the dangerous substance. The attractive nuisance doctrine had no application. The following statement in the case of *Keck v. Woodring*, 201 Okl. 665 is particularly applicable here:

‘Whether the child was of an age and capacity to understand and avoid danger is usually a question for the jury, but it may be stated as a settled rule in this state that after the age of fourteen all minors are prima facie presumed to be capable of the exercise of judgment and discretion. Plaintiff being over the age of fourteen, and there being no evidence of lack of capacity, but, on the contrary, there being evidence that plaintiff was of advanced intelligence, the trial court should have held as a matter of law that the rule of attractive nuisance could not be invoked.’

Citation of authority is unnecessary to support the rule that in order for *759 plaintiff to recover in an action founded upon negligence, proof must be made of the essential elements; that defendant had duty to protect injured person from injury; that defendant failed to perform that duty, and that such failure was proximate cause of injury. The lack of proof of any one of these elements is fatal to the action. In the case before us there is a complete absence of proof of any duty to plaintiff owed by any of the defendants. Even though the means had been at hand to stop plaintiff from hammering the pipe, none of the defendants was obligated to do so.

‘As a general rule, the law imposes no duty on one person actively to assist in the preservation of the person or property of another from injury, even though the means by which harm can be averted are in his possession. The law does not undertake to make men render active service to their neighbors at all times when a good or brave man would do so.

‘Those duties which are dictated merely by good morals, or by humane considerations, are not within the domain of the law.’ 38 Am.Jur. 658, Negligence sec. 16.

The last quoted rule is also applicable to the minor defendants, McVay and Peterson. None of the evidence tended to establish a duty due from them to plaintiff nor any breach of duty. There was testimony that these latter defendants, as they were seeking a place of safety, tried to get plaintiff to stop hammering on the bomb. Since, however, the plaintiff denied it and the matter was presented on demurrer, there was no proof that they sanctioned or encouraged the dangerous acts.

Plaintiff’s evidence wholly failed to establish any of the essentials above enumerated entitling him to recover. [***] Therefore, the trial court committed no error in sustaining the several demurrers to the evidence of plaintiff.

The judgment is affirmed.

Note 1. How important do you think the boys’ age and gender were to this case? Do you think contemporary parenting models might prompt different analysis from a court today?

Note 2. No Duty to Rescue. *Sidwell* reinforces the general proposition that there is no duty to rescue in American tort law. That is, there is no duty to take affirmative steps to help or “rescue” another who faces a risk or harms you did not create through your negligence or contribute to increasing. “Rescue” does not mean only traditional rescues such as helping someone out of a difficult spot in the moment when it is happening, but more broadly, the undertaking of steps to assist or warn the injured or vulnerable. Tort law does not require taking action to help someone unless you have a special relationship or contract or fall into one of the exceptions or categories in which specific duties are articulated. Even then, expect to see rulings of “no duty” in many cases where *some* duty might be owed to some people, at some times. Consider that in *Harper* the victim was a guest on the defendant’s boat but that social relationship alone and the boat’s ownership did not give rise to a duty to warn; in *Sidwell*, although the boys were friends and all involved in experimenting with the explosives to some extent, their joint efforts were not enough to give rise to a duty to interfere with or impede the plaintiff from his own decisions to hammer the pipe bomb.

Note 3. Policy Considerations Underpinning the No Duty to Rescue Rule. Some scholars have called out the uniquely American nature of the no duty rule.

With a few exceptions, the general rule in American tort law is that bystanders will not be liable to a victim for their failure to affirmatively aid. There is, in other words, no general duty to reasonably rescue in American law. This feature of American tort law differs markedly from the legal treatment of the same issue in other parts of the world where legal obligations to affirmatively aid another in peril are common. It stands also in striking contrast to most conventional views of common decency and morality. [But] a full understanding of the no-duty-to-rescue doctrine begins with an appreciation that

it is less an affirmative assertion of preferred behavior and outcomes than a tenet of tort law not to extend the usual regulatory pressures of negligence into this particular nook of human judgment.

Marin Roger Scordato, *Understanding the Absence of A Duty to Reasonably Rescue in American Tort Law*, 82 Tul. L. Rev. 1447, 1452 (2008)

Emphasizing its difference from other jurisdictions denaturalizes the no duty rule and illuminates the fact that philosophical and economic values underpin our system's continued adherence to it. Scordato has argued that it would impose considerable costs on society to impose a general duty to rescue, and contrasted such a general duty to rescue with a more limited duty that could be imposed on those with expertise in related areas. Other scholars have explored the philosophical implications of retaining the no-duty rule or abandoning it, and there have been spirited defenses of it as a mechanism that reflects tort law's concern with efficiency. See William M. Landes & Richard A. Posner, *Salvors, Finders, Good Samaritans, and Other Rescuers: An Economic Study of Law and Altruism*, 7 J. Legal Stud. 83, 119-27 (1978) (arguing in part that would-be rescuers will avoid morally worthy attempts to rescue if liability for doing or not doing so exists). Still others have argued the opposite, advocating in favor of a liability rule. See Richard L. Hasen, *The Efficient Duty to Rescue*, 15 Int'l Rev. L. & Econ. 141, 147 (1995).

Is this an area of law in which making a choice based on efficiency seems advisable to you? Why or why not? What philosophical perspective do you think the law *should* adopt?

Farwell v. Keaton, Supreme Court of Michigan (1976) (396 Mich. 281)

There is ample evidence to support the jury determination that David Siegrist failed to exercise reasonable care after voluntarily coming to the aid of Richard Farwell and that his negligence was the proximate cause of Farwell's death. We are also of the opinion that Siegrist, who was with Farwell the evening he was fatally injured and, as the jury found, knew or should have known of his peril, had an affirmative duty to come to Farwell's aid.⁷³

On the evening of August 26, 1966, Siegrist and Farwell drove to a trailer rental lot to return an automobile which Siegrist had borrowed from a friend who worked there. While waiting for the friend to finish work, Siegrist and Farwell consumed some beer. Two girls walked by the entrance to the lot. Siegrist and Farwell attempted to engage them in conversation; they left Farwell's car and followed the girls to a drive-in restaurant down the street. The girls complained to their friends in the restaurant that they were being followed. Six boys chased Siegrist and Farwell back to the lot. Siegrist escaped unharmed, but Farwell was severely beaten. Siegrist found Farwell underneath his automobile in the lot. Ice was applied to Farwell's head. Siegrist then drove Farwell around for approximately two hours, stopping at a number of drive-in restaurants. Farwell went to sleep in the back seat of his car. Around

⁷³ The trial judge instructed the jury to determine whether Siegrist had voluntarily undertaken to render aid and, if he had, whether he acted reasonably in discharging that duty. Whether Siegrist be charged with the duty of a voluntary rescuer or the duty of a companion, the standard of care—whether he acted reasonably under all the circumstances—is the same and the instruction given was adequate.

midnight Siegrist drove the car to the home of Farwell's grandparents, parked it in the driveway, unsuccessfully attempted to rouse Farwell, and left. Farwell's grandparents discovered him in the car the next morning and took him to the hospital. He died three days later of an epidural hematoma.

At trial, plaintiff contended that had Siegrist taken Farwell to the hospital, or had he notified someone of Farwell's condition and whereabouts, Farwell would not have died. A neurosurgeon testified that if a person in Farwell's condition is taken to a doctor before, or within half an hour after, consciousness is lost, there is an 85 to 88 per cent chance of survival. Plaintiff testified that Siegrist told him that he knew Farwell was badly injured and that he should have done something.

The jury returned a verdict for plaintiff and awarded \$15,000 in damages. The Court of Appeals reversed, finding that Siegrist had not assumed the duty of obtaining aid for Farwell and that he neither knew nor should have known of the need for medical treatment.

Two separate, but interrelated questions are presented:

- A. Whether the existence of a duty in a particular case is always a matter of law to be determined solely by the Court?
- B. Whether, on the facts of this case, the trial judge should have ruled, as a matter of law, that Siegrist owed no duty to Farwell?

'A duty, in negligence cases, may be defined as an obligation, to which the law will give recognition and effect, to conform to a particular standard of conduct toward another.' Prosser, *Torts* (4th ed.), s 53, p. 324. The existence of a duty is ordinarily a question of law. However, there are factual circumstances which give rise to a duty. The existence of those facts must be determined by a jury.⁷⁴ In *Bonin v. Gralewicz*, 378 Mich. 521, 526—527 (1966), this Court reversed a directed verdict of no cause of action where the trial court had determined as a matter of law that the proofs were insufficient to establish a duty of care:

'Usually, in negligence cases, whether a duty is owed by the defendant to the plaintiff does not require resolution of fact issues. However, in some cases, as in this one, fact issues arise. When they do, they must be submitted to the jury, our traditional finders of fact, for ultimate resolution, and they must be accompanied by an appropriate conditional instruction regarding defendant's duty, conditioned upon the jury's resolution of the fact dispute.'

This same rule was stated more recently in *Davis v. Thornton*, 384 Mich. 138, 142, (1970). 'The trial judge in this case determined the defendant owed the plaintiff no duty. We believe this conclusion could properly be made only by a jury.'

Without regard to whether there is a general duty to aid a person in distress, there is a clearly recognized legal duty of every person to avoid any affirmative acts which may make a situation worse. '(I)f the defendant does attempt to aid him, and takes charge and control of the situation, he is regarded as entering voluntarily into a relation which is attended with responsibility. Such a defendant will then be

⁷⁴ Of course, merely labeling a question as one of 'law' or 'fact' does not solve the dilemma. 'No two terms of legal science have rendered better service than 'law' and 'fact' * * *. They readily accommodate themselves to any meaning we desire to give them * * *. What judge has not found refuge in them? The man who could succeed in defining them would be a public enemy.' Leon Green, *Judge and Jury*, p. 270.

liable for a failure to use reasonable care for the protection of the plaintiff's interests.' [***] In a case such as the one at bar, the jury must determine, after considering all the evidence, whether the defendant attempted to aid the victim. If he did, a duty arose which required defendant to act as a reasonable person.

'Before any duty, or any standard of conduct may be set, there must first be proof of facts which give rise to it,' Prosser, *Supra*, s 37, p. 205. Whether those facts have been proved is a question for the jury. [***] There was ample evidence to show that Siegrist breached a legal duty owed Farwell. Siegrist knew that Farwell had been in a fight, and he attempted to relieve Farwell's pain by applying an ice pack to his head. While Farwell and Siegrist were riding around, Farwell crawled into the back seat and laid down. The testimony showed that Siegrist attempted to rouse Farwell after driving him home but was unable to do so.

In addition, Farwell's father testified to admissions made to him by Siegrist:

'Q. Witness, just before the jury was excused, I asked whether you had any conversation with Mr. Siegrist after this event occurred. You answered, 'Yes, the day *289 after in the living room of Mrs. Grenier's (the deceased's mother) home.' Then, the jury was excused, and we made a special record, and now I would like to ask you some questions that I asked and that you answered out of the presence of the jury.

'A. Yes.

'Q. What did Mr. Siegrist say, how did the conversation go?

'A. I asked him why he left Ricky (the deceased) in the driveway of his grandfather's home.

'Q. What did he say?

'A. He said '*Ricky was hurt bad, I was scared.*' I said, '*Why didn't you tell somebody, tell his grandparents*'?' He said, '*I know I should have, I don't know.*' (Emphasis added).

The question at trial came down to whether Siegrist acted reasonably under all the circumstances. [***] The jury in this case found that Siegrist did not act reasonably, and that his negligence was the proximate cause of Farwell's death.

[***] Siegrist contends that he is not liable for failure to obtain medical assistance for Farwell because he had no duty to do so. Courts have been slow to recognize a duty to render aid to a person in peril.⁷⁵ Where such a duty has been found, it has been predicated upon the existence of a special

⁷⁵ '*** The law has persistently refused to recognize the moral obligation of common decency and common humanity, to come to the aid of another human being who is in danger ***. The remedy in such cases is left to the 'higher law' and the 'voice of conscience,' which, in a wicked world, would seem to be singularly ineffective either to prevent the harm or to compensate the victim.' Prosser, *Torts* (4th ed.), s 56, pp. 340—341. 'At the other end of the spectrum are cases where the peril to the plaintiff has come from a source in no way connected with defendant's conduct or enterprises or undertakings, past or present, but where the defendant has it in his power by taking some reasonable precaution to remove the peril. Here the law has traditionally found no duty, however reprehensible and unreasonable the defendant's failure to take the precaution may be. * * * There is no legal obligation to be a Good Samaritan.' Harper & James, *The Law of Torts*, s 18.6, p. 1046.

relationship between the parties;⁷⁶ in such a case, if defendant knew or should have known of the other person's peril, [fn] he *291 is required to render reasonable care under all the circumstances. [fn]

[***] The Sixth Circuit Court of Appeals, in *Hutchinson v. Dickie*, 162 F.2d 103, 106 (C.A. 6, 1947), said that a host had an affirmative duty to attempt to rescue a guest who had fallen off his yacht. The host controlled the only instrumentality of rescue. The Court declared that to ask of the host anything less than that he attempt to rescue his guest would be 'so shocking to humanitarian considerations and the commonly accepted code of social conduct that the courts in similar situations have had no difficulty in pronouncing it to be a legal obligation.'

Farwell and Siegrist were companions on a social venture. Implicit in such a common undertaking is the understanding that one will render assistance to the other when he is in peril if he can do so without endangering himself. Siegrist knew or should have known when he left Farwell, who was badly beaten and unconscious, in the back seat of his car that no one would find him before morning. Under these circumstances, to say that Siegrist had no duty to obtain medical assistance or at least to notify someone of Farwell's condition and whereabouts would be 'shocking to humanitarian considerations' and fly in the face *292 of 'the commonly accepted code of social conduct.' [fn] (C)ourts will find a duty where, in general, reasonable men would recognize it and agree that it exists. [fn]

Farwell and Siegrist were companions engaged in a common undertaking; there was a special relationship between the parties. Because Siegrist knew or should have known of the peril Farwell was in and could render assistance without endangering himself he had an affirmative duty to come to Farwell's aid.

The Court of Appeals is reversed and the verdict of the jury reinstated.

FITZGERALD, Justice (dissenting).

The unfortunate death of Richard Farwell prompted this wrongful death action brought by his father against defendant, David Siegrist, a friend who had accompanied Farwell during the evening in which the decedent received injuries which ultimately cause his death three days later. The question before us is whether the defendant, considering his relationship with the decedent and the activity they jointly experienced on the evening of August 26—27, 1966, by his conduct voluntarily or otherwise assumed, or should have assumed, the duty of rendering medical or other assistance to the deceased. We find that defendant had no obligation to assume, nor did he assume, such a duty.

The facts of the case are accurately set forth in the Court of Appeals opinion.

'Factually, it appears that, on August 26, 1966, Richard Murray Farwell, deceased eighteen-year-old son of the plaintiff, visited the home of his friend, David Siegrist, a sixteen-year-old; that evening they drove to a trailer rental lot, where Siegrist was returning an automobile he had borrowed from a friend who was employed by the rental agency.

'Siegrist and Farwell planned to wait in the car until the friend had finished work and then 'drive around, 'stopping at various restaurants and drive-ins. While they were waiting, Seigrist estimated that they consumed 'four or five' beers each. Shortly before nine o'clock p.m., two teenage girls walked

⁷⁶ Carriers have a duty to aid passengers who are known to be in peril [cc] Maritime law has imposed a duty upon masters to rescue crewmen who fall overboard. [cc]

past the car. After an unsuccessful attempt to engage them in conversation, Farwell left the car and followed the girls; Siegrist got out of the car and followed Farwell.

‘When the girls reached a restaurant a short distance down the street, they apparently complained to those present that they were being followed. Defendants Inland, Brock, Donald Keaton, Daniel Keaton, and at least two others in the restaurant began to chase Farwell and Siegrist, both of whom ran back to the trailer lot. Siegrist escaped by ducking into the trailer rental office, where he requested those inside to assist Farwell. They stepped out of the office and were confronted by the group which had been chasing Siegrist and Farwell. The two groups faced each other, but no violence ensued, and the two groups scattered.

‘It was then discovered for the first time that Farwell had been caught and beaten by those who had been pursuing him and Siegrist; Farwell was found underneath his automobile in the lot.

‘Farwell was taken to the trailer rental office, where Siegrist gave him a plastic bag full of ice for his injuries. Shortly thereafter, Farwell and Siegrist left the rental office and, between ten o’clock p.m. and midnight, they visited four different drive-in restaurants. While en route from the third to the fourth restaurant, Farwell stated that he wanted to lie down, climbed into the back seat, and went to sleep. Around midnight, Siegrist drove the car to the home of Farwell’s grandparents, parked it in the driveway, and attempted to rouse Farwell. When the latter merely made a sound as ‘if in a deep sleep’, Siegrist left with a friend who had followed him to the grandparents’ house. The next morning, Farwell was found by his grandparents, apparently taken to a hospital, and died of an epidural hematoma.

‘At the close of plaintiff’s proofs, defendant Siegrist moved for a directed verdict on the grounds that he had no duty to obtain medical assistance for Farwell as a matter of law. In the alternative, the motion was based upon the proposition that plaintiff failed to establish that any conduct on the part of Siegrist proximately caused Farwell’s death. The motion was denied.’[c]

Following the jury verdict of \$15,000 in favor of the plaintiff, defendant, arguing that the verdict was inconsistent with the weight of the evidence, moved for and was denied a judgment notwithstanding the verdict. The decision of the trial court was reversed by the Court of Appeals which found that the defendant never assumed, voluntarily or otherwise, the duty of obtaining medical assistance for the deceased. The Court stated that the facts in no way indicated that defendant knew, or should have known, that immediate medical attention was required. Consequently, as a matter of law the Court determined that defendant was under no duty to obtain medical treatment for the decedent.

Plaintiff argues that once having voluntarily undertaken the duty of caring for decedent, defendant could not discontinue such assistance if, in so doing, he left the decedent in a worse position than when such duty was assumed. Defendant’s knowledge of the seriousness of decedent’s injury and the failure to advise decedent’s grandparents, the close personal relationship that existed between defendant and the decedent, and the supposition that the decedent relied upon defendant for assistance leads plaintiff to conclude that defendant did not act ‘with the reasonable prudence and care of a reasonable man in the same or like circumstances’. Defendant’s position is that there was no volunteered assumption of duty to care for the safety of the decedent. He argues that the facts within his knowledge on the evening of August 26, 1966, and the evidence introduced at trial failed to establish that defendant should have seen that Richard Farwell had suffered a potentially fatal injury requiring immediate attention.

Defendant did not voluntarily assume the duty of caring for the decedent's safety. Nor did the circumstances which existed on the evening of August 26, 1966, impose such a duty. Testimony revealed that only a qualified physician would have reason to suspect that Farwell had suffered an injury which required immediate medical attention. The decedent never complained of pain and, in fact, had expressed a desire to retaliate against his attackers. Defendant's inability to arouse the decedent upon arriving at his grandparents' home does not permit us to infer, as does plaintiff, that defendant knew or should have known that the deceased was seriously injured.⁷⁷ While it might have been more prudent for the defendant to insure that the decedent was safely in the house prior to leaving, we cannot say that defendant acted unreasonably in permitting Farwell to spend the night asleep⁷⁸ in the back seat of his car.

The close relationship between defendant and the decedent is said to establish a legal duty upon defendant to obtain assistance for the decedent. No authority is cited for this proposition other than the public policy observation that the interest of society would be benefited if its members were required to assist one another. This is not the appropriate case to establish a standard of conduct requiring one to legally assume the duty of insuring [*sic*] the safety of another. Recognizing that legal commentaries have expressed moral outrage at those decisions⁷⁹ which permit one to refuse aid to another whose life may be in peril, we cannot say that, considering the relationship between these two parties and the existing circumstances, defendant acted in an unreasonable manner.⁸⁰

Plaintiff believes that a legal duty to aid others should exist where such assistance greatly benefits society and only a reasonable burden is imposed upon those in a position to help. He contends further that the determination of the existence of a duty must rest with the jury where questions of foreseeability and the relationship of the parties are primary considerations.

It is clear that defendant's nonfeasance, or the 'passive inaction or a failure to take steps to protect (the decedent) from harm'⁸¹ is urged as being the proximate cause of Farwell's death. We must reject plaintiff's proposition which elevates a moral obligation to the level of a legal duty where, as here, the facts within defendant's knowledge in no way indicated that immediate medical attention was necessary and the relationship between the parties imposes no affirmative duty to render assistance.

⁷⁷ It is at this point—plaintiff's unsuccessful attempt to arouse the decedent in the driveway—that counsel, during oral argument, believes that defendant volunteered to aid the decedent. Yet no affirmative act by defendant indicated that he assumed the responsibility of rendering assistance to the decedent. Consequently, there could be no Discontinuance of aid or protection which left decedent in a worse position than when the alleged 'volunteering' occurred. This would make operative the concession of plaintiff that where no duty is owed, the refusal to act cannot form the basis for an action in negligence.

⁷⁸ Defendant had no way of knowing that it was the severity of the head injury suffered by the decedent which caused him to crawl in the back seat and apparently fall asleep. The altercation combined with the consumption of several beers could easily permit defendant to conclude that decedent was simply weary and desired to rest.

⁷⁹ The most notable of which include: *Osterlind v. Hill*, 263 Mass. 73, 160 N.E. 301, 56 A.L.R. 1123 (1928) [cc].

⁸⁰ Were a special relationship to be the basis of imposing a legal duty upon one to insure the safety of another, it would most probably take the form of 'co-adventurers' who embark upon a hazardous undertaking with the understanding that each is mutually dependent upon the other for his own safety. There is no evidence to support plaintiff's position that decedent relied upon defendant to provide any assistance whatsoever. A situation where two persons are involved in an altercation provoked by the party ultimately injured, the extent of which was unknown to the other, whose subsequent conduct included drinking beer and a desire to retaliate against his attackers would not fall within this category.

⁸¹ Prosser, *Torts* (4th ed.), s 56, pp. 338—339.

See *Steckman v. Silver Moon, Inc.*, 77 S.D. 206, 90 N.W.2d 170, 64 A.L.R.2d 1171 (1958). The posture of this case does not permit us to create a legal duty upon one to render assistance to another injured or imperiled party where the initial injury was not caused by the person upon whom the duty is sought to be imposed.

The relationship of the parties and the question of foreseeability does not require that the jury, rather than the court, determine whether a legal duty exists. We are in agreement with the general principle advanced by plaintiff that the question of negligence is one of law for the court only when the facts are such that all reasonable men must draw the same conclusion.⁸² However, this principle becomes operative only after the court establishes *298 that a legal duty is owed by one party to another. Prosser's analysis of the role of the court and jury on questions of legal duty, recently quoted in *Moning v. Alfonso, Mich.* (1975), bears repeating:

'The existence of a duty [***] is entirely a question of law, to be determined by reference to the body of statutes, rules, principles and precedents which make up the law; and it must be determined only by the court. * * * A decision by the court that, upon any version of the facts, there is no duty, must necessarily result in judgment for the defendant,' Prosser, *Torts* (4th ed.), s 37, p. 206.

Michigan recognizes that the question of duty is to be resolved by the court rather than the jury. [c] The Court of Appeals properly decided as a matter of law that defendant owed no duty to the deceased.

We would affirm.

Note 1. Why do you think the dissent goes to the trouble of revisiting and re-narrating the facts?

Note 2. Wingman Liability. This case has come to be cited for the creation of something called "wingman liability"—one owes a duty to one's co-adventurer or "wingman" for the evening, even when one generally does not owe a duty of care to one's fellow travelers in the world. It goes beyond simply owing a duty of care for one's friends, very generally; instead, it seems to impose liability for harms that befall one's companion for that evening, if one were in a position to curb or prevent those harms. What does that rule do to life on many residential college campuses? Put another way, what would the rule do to life on such campuses if legal rules were things that meaningfully shaped the conduct of actors in that age group (whether rules do or don't is an open question, but assume for the moment that students knew about this rule and its consequences) ... would anything change, in your view?

Note 3. Duty as Relational versus Duty as Act-Centered. Duty is often considered categorically, in terms of classes of actors or entities who owe duties to other classes of actors or entities. But in some cases, courts find particularized duties to given individuals. Should a therapist aware of a specific deadly threat by their client to a third party outside their care be found to owe a duty to that threatened individual? (*See supra, Tarasoff v. Regents of the Univ. of Cal.*, 551 P.2d 334, 340 (Cal. 1976) (yes). Should an adulterer aware of a sexually transmitted disease be found liable to the spouse of his lover to refrain from transmitting it to him? (*Mussivand v. David*, 544 N.E.2d 265, 270 (Ohio 1989) (yes).

⁸² *McCullough v. Ward Trucking Co.*, 368 Mich. 108, 117 N.W.2d 167 (1962); *Barnbee v. Spence Brothers*, 367 Mich. 46, 116 N.W.2d 49 (1962).

If foreseeability is the rationale behind both of these instances, should it matter how the court crafts its decision and how broad a duty it defines? In *Tarasoff*, the court created a broad duty on any psychologists or relevant social workers to all foreseeable nonpatients at risk of credible attack by a patient. In *Mussivand* by contrast, the court found a specific duty ran between the parties but did not articulate a broader class. How far should foreseeability go in establishing duty and how granular should courts get? Decision by a judge can enable a broadly defined scope of foreseeability whereas determination by a jury at the proximate cause stage requires case-sensitive decisionmaking that will necessarily be narrower. While the study of proximate cause is still ahead of you, it is important to begin to see the significance of defining the scope of tort law and allocating decisional authority to the judge (to decide the case as a function of duty) or the jury (to decide it as a function of proximate cause).

One critique of the notion of duty as relational (associated with Cardozo's opinion in *Palsgraf*) argues that the relational theory does not align with how people act, which is better captured in an act-centered view (associated with Andrews' dissent). Prominent torts scholars elaborate on this difference as follows:

In most circumstances, one does not act toward others at all. If one considers doing an act—driving a motorcycle, going for a jog, shooting a gun, or even having sex—one typically considers only whether the act might create a risk generally. If so, then one feels an obligation to take care in doing the act. Of course, once one is motivated by a sense of obligation, one might then consider the number, proximity, and vulnerability of others in determining what constraints on an activity might be required. This second step in one's thinking, however, is an analysis of reasonableness—a matter for breach, not duty. Obligation-based duty reasoning seeks the internal—albeit objective—perspective of a person in the defendant's position at the time of acting. ...[W]e think that obligations to act reasonably are most accurately described as act centered and nonrelational. ... Returning to the facts of *Mussivand*, it would seem callous and strange to say that one owes an obligation to avoid infecting one's sexual partner [under a relational view of duty narrowed as under *Mussivand*], but no obligation to avoid spurring the infection of an entire community [under an act-centered nonrelational approach to duty].

W. Jonathan Cardi & Michael D. Green, *Duty Wars*, 81 S. Cal. L. Rev. 671, 720 (2008) (citations omitted and emphasis added).

Which seems to you the better approach, at this point? Does your answer depend on who makes the determination, judge or jury? To what extent does duty inevitably begin to entail discussions of breach of that duty and inquiries into the defendant's conduct? How does this inquiry change—and how *should* it change—over time?

Exceptions to the No Duty to Rescue Rule

The Restatement sets out clear exceptions under which a duty to rescue arises. The Restatement (Second) of Torts § 314 makes clear that “The fact that the actor realizes or should realize that action

on his part is necessary for another's aid or protection does not of itself impose upon him a duty to take such action.”

Section 314A of the Restatement (Second) of Torts provides the following exceptions to the general rule that one person need not assist another:

§ 314A. Special Relations Giving Rise to Duty to Aid or Protect

- (1) A common carrier is under a duty to its passengers to take reasonable action:
 - (a) to protect them against unreasonable risk of physical harm, and
 - (b) to give them first aid after it knows or has reason to know that they are ill or injured, and to care for them until they can be cared for by others.
- (2) An innkeeper is under a similar duty to his guests.
- (3) A possessor of land who holds it open to the public is under a similar duty to members of the public who enter in response to his invitation.
- (4) One who is required by law to take or who voluntarily takes the custody of another under circumstances such as to deprive the other of his normal opportunities for protection is under a similar duty to the other.

The duty that arises under Section 314A exists because of the special relationship between the parties. Restatement § 314A, cmt. b. The relationships listed in the rule are not intended to be exclusive, *id.* Nevertheless, some courts have restricted the application of § 314A to business invitees.

The Restatement illustrates contexts in which arise both common law and statutory exceptions to that general “no duty to rescue” rule. For instance, an entity may have a duty to give first aid or assist someone with whom it stands in a special relationship. Other examples provided by the Restatement include a common carrier exception (recall the doctrine imposing a higher duty on common carriers first seen in *Gulf v. Luther*); an innkeeper (on similar grounds as common carriers); a possessor of land; and someone who undertakes custody of another. In addition, courts tend to find such duties when a special relationship exists (think parent/child, employer/employee, caregiver/dependent, close friends, perhaps even teacher/student). Special duties can also arise by contract (employment contracts, or contracts to provide services) as well as through certain other relationships governed by legal principles, such as those shaping property ownership and imposing premises liability in certain instances.

Duties of Common Carriers and Innkeepers

The next case revisits the common carrier doctrine (which you saw in *Gulf v. Luther*). Historically, common carriers and innkeepers were subject to a heightened duty of care as reflected in the Restatement's § 314(A). *Bullock v. Tamiami* explores that duty and the standard of reasonable care implied by such a duty in the context of the segregated South. The Civil Rights Movement would ultimately force an end to legally permitted segregation. However, in *Bullock*, you will find outright

racism (and outdated language) as well as facts involving violent assault for which the law provides a remedy on the basis of a heightened duty.

**Bullock v. Tamiami Tours Inc., United States Court of Appeals Fifth Circuit
(1959)
(266 F.2d 326)**

The appellants are Negroes, British subjects, natives of Jamaica, married to each other, and in their early fifties. For more than twenty years the husband has been a minister of the Church of England. The wife is a musician and teacher. Racial segregation is not practiced in the island of Jamaica.

Prior to 1956, the appellants had left that island on only one trip and that was to European countries and South American countries which did not segregate the races. They were not familiar with the racial segregation practiced in the Southern part of the United States.

In August 1956, they decided to make an extended visit to the United States, landing in Miami and going by bus first to Kansas City and then to New York. They made arrangements for the trip through the Mountain Travel Service before leaving Jamaica and bought tickets over the appellee's bus line. When the bus arrived in Perry, Florida, they were sitting together in the forward part of the bus usually occupied by white passengers. The husband was dark or black, while the wife, though a Negress, appeared to be a white woman.

At Perry, Florida, one Milton Poppell entered the bus and violently assaulted and beat the husband and slapped the wife. The circumstances are well described in the testimony of Poppell, quoted in the margin.⁸³ Other evidentiary *329 facts are stated in some detail in the opinion of the district court reported in 162 F. Supp. at page 203 et seq.

⁸³ Q. Mr. Poppell did you go on a bus in Perry and assault this man right here? A. Yes, I did.

Q. Did you know he was on that bus before you went on there? A. Well, yes, I did.

Q. Is that the reason you went on the bus? A. Well, not exactly.

Q. Where were you going on that trip? A. I have got a farm out this side of Perry.

Q. About how far is it? A. Approximately ten miles, maybe twelve.

Q. Mr. Poppell, how did you know that the Reverend Bullock was on that bus? A. Well, the police and I were sitting down there drinking coffee and I overheard the conversation of the bus driver telling the police that they were on there. He didn't say they were on there, he said, talking to them, 'fellows look what I have got to contend with and nothing I can do about it.' And the police says, 'our hands are tied too.'

Q. He told that to the police officers? A. The best I remember that was the words said.

Q. You heard— how far away were you? A. Well, I was sitting down there at the table.

Q. At the table with the police officers? A. Yes, I was.

Q. Then what did you say? A. I didn't say anything right then. In a few minutes I got up and asked if I could buy a ticket on the bus.

Q. You asked the bus driver that? A. Yes.

Q. Then what did he say? A. He said he had them for sale.

Q. Mr. Poppell have you got anything against colored people, generally? A. Not as long as they stay in their place.

Q. Well, why did you assault him? A. Because he was out of his place.

Q. How did you know he was out of his place? The bus wasn't full then, was it? A. Not at that time, it wasn't, but when everybody got on it was full. Whenever I got on it wasn't full.

Q. How do you know it wasn't full? A. Well, there was plenty of loading space in the rear of the bus, but there wasn't any in the front.

Q. Did anything the bus driver say lead you to believe he wasn't in his place? A. Well, I don't know whether you would figure it was what the bus driver said or what I felt that he was out of his place too.

Q. Isn't it true that you wouldn't have known, Mr. Poppell, about the Bullocks being on the bus if it had not been for the bus driver? A. Well, I probably wouldn't have noticed it.

Q. Then if you hadn't noticed it, you would not have gotten on the bus, isn't that right? A. Well, I couldn't say whether I would or wouldn't, because I just really don't know whether I would have gotten on there or not. My intention was not getting on there but then I decided to go.

Q. At the time you heard the bus driver speaking you had no intention of getting on that bus, and you had your car didn't you? A. Yes, I did. I reckon I did. Yes, I did.

Q. And when you heard the bus driver say something then you decided to get on the bus, isn't that right? A. Yes, that helped.

Q. Mr. Poppell in your testimony in this court yesterday, you stated that you had nothing against colored people? A. that's right.

Q. You added that if they kept their place? A. That's right.

Q. Did you attack the Reverend Bullock simply from the fact he was seated on the bus? A. Well, yes. And I wanted to see and as a matter of fact he was with a white woman.

Q. What do you mean, with a white woman? A. Well, his wife is supposed to be white, I understand.

Q. How did you know who his wife was? Had you ever known the Bullocks before this? A. No.

Q. How did you know who his wife was? A. Well, she was pointed out as she came in the bus station.

Q. Was it the bus driver that pointed her out? A. I believe he made a remark to the policeman that that was his wife coming in.

Q. How did you happen to hear this? A. Well, I was sitting with the policemen.

Q. With the policemen? A. Yes, sir.

Q. How far were you from the bus driver? A. Well, it is just like the table in the restaurant, I was sitting down at one end of it and one of the policemen was sitting on the opposite side and one on this side. And the bus driver walked up to the table.

After reaching New York, the appellants brought suit against the appellee in a New York State Court, claiming that the appellee had breached the duties owed to them as passengers by omitting to warn them of a foreseeable danger, by failing to protect them from that danger, and by willfully, or at least negligently, aggravating the danger. The appellee, incorporated under the laws of Florida, being sued by citizens and subjects of *330 Great Britain, had the case removed to the United States District Court for the Eastern District of New York [Under 1332]. That Court transferred the action to the United States District Court for the Northern District of Florida [Under 28 U.S.C.A. § 1404].

There the case was tried to the court without a jury. After fairly finding the evidentiary facts in a manner to which the appellants take only minor exceptions, the district court entered judgment for the defendant, feeling that the law of the State of Florida required it to do so, and said in part:

Q. And he spoke to the policemen? A. Yes.

Q. And what did he say, Mr. Powell (sic), again? A. I believe he says, and that is his wife there.’

Q. And he pointed out Mrs. Bullock? A. Yes.

Q. And she appeared to you to be white at that time? A. Yes, she did.

Q. Did he say anything about the man on the bus being married to a white woman? A. I don’t remember.

Q. Maybe this will refresh your recollection—did he say the man on the bus was married to a white woman? A. I believe he did.

Q. Did you hear it? A. Yes.

Q. How far away were you from him? A. Well, he was standing at the head of the table and I was sitting down.

Q. Now, of the two things, which do you think is the worse, in your opinion—A. Well, that’s about fifty-fifty proposition.

Q. You mean you don’t like either one? A. Either one. Otherwise he was out of his place in my opinion in the front of the bus and he was certainly out of his place being married to a white woman.

Q. Mr. Poppell when you went in there and asked him to move you didn’t give him a chance to move? A. Well, I expected a fight back so I didn’t give him too much a chance.

Q. Why did you expect a fight back? A. I didn’t figure he was going to give up his seat.

Q. Why did you figure that he wouldn’t give up the seat? A. Well, just a matter of may [sic] opinion.

Q. Is it a practice that all colored people in Perry have to move back? A. Yes.

Q. Why did you expect this to be any different? A. Well, I guess by him riding so far without any trouble.

Q. Actually didn’t you know that he had been asked to move? A. Yes, I did.

Q. How did you find that out? A. I believe that the bus driver made the statement.

Q. Now, is it your testimony that everything you knew about this man came from the bus driver or was there anyone else who told you anything about it? A. No, it wasn’t discussed. The bus driver didn’t tell me anything at all and it wasn’t discussed with anybody else. All I knew was what I overheard.

‘In *Hall v. Seaboard Air Line Ry. Co.*, 84 Fla. 9, the Florida Supreme Court held that a carrier was not liable to a passenger for an unprovoked and illegal assault in cases such as this case. Without regard to the views of this Court as to what the law should be in such a case as this the decision of this Court is completely controlled by the decision of the Supreme Court of Florida in the case cited above. ‘*Erie Railroad Company v. Tompkins*, 304 U.S. 64, 58 S.Ct. 817,’ *Bullock v. Tamiami Trail Tours*, D.C.N.D. Fla.1958.

We are not in agreement with the district court either as to the Florida law or as to the ultimate facts, inferences or conclusions of duty and breach of duty on the part of the appellant carrier. In so far as those ultimate facts are simply the result reached by processes of legal reasoning from, or the interpretation of the legal significance of, the evidentiary facts, they are subject to review by this Court free from the restraining influence of the ‘clearly erroneous’ rule, Rule 52(a), Federal Rules of Civil Procedure, 28 U.S.C.A.; [c]. To the extent that the inference of negligence is controlled by Rule 52(a), supra, this Court, on the entire evidence, ‘is left with the definite and firm conviction that a mistake has been committed.’ [c].

In *Hall v. Seaboard Air Line Ry. Co.*, 84 Fla. 9, 93 So. 151, the case relied upon by the district court as dispositive of the case at bar, a female passenger was assaulted by a male passenger in a Pullman berth, they being the only two occupants of the car. Holding that the plaintiff’s proof failed to support her allegations that a porter and conductor heard her calls and bells in time to have prevented the assault, the court stated:

‘The liability of the carrier in such case rests, not upon the tort of the passenger, but upon the negligent omission of the carrier through its servants to prevent the tort being committed. A failure to do anything which could have been done by the servant to prevent the injury renders the carrier liable. But to do something to prevent an injury resulting from an assault by a fellow passenger implies knowledge on the part of the servant that the act is contemplated by the stranger, or by due diligence the servant could have obtained such knowledge, or had the opportunity to acquire it sufficiently long in advance of its infliction to have prevented it with the force at his command. [c]

‘In guarding a passenger from a danger which is not usual or not incident to ordinary travel the carrier is held to the use of ordinary and reasonable care and diligence. It is the failure of the carrier through its agents to afford the required protection, after they had reasonable grounds for believing that violence or the insult was imminent, upon which the liability of the carrier rests. It is not the fact of injury to the passenger that fixes the carrier’s liability. The injury must have been of such character and inflicted under such circumstances as that it might *331 have been reasonably anticipated or naturally expected to occur.’ [c]

In *Kenan v. Houstoun*, 1952, 150 Fla. 357, where, after alighting from the Florida East Coast train, plaintiff was struck on the legs by an ejection of steam from a nearby L&N train causing her to move about rapidly and fall over baggage, the court, in quashing a judgment against the Florida East Coast Railway, stated:

‘* * * When it appears that the agency which caused the injury was other than defendant or its agents the plaintiff must prove that defendant knew or by the exercise of ordinary care could have known of it in time to remove the cause of the injury. [c]

‘It is settled law that under the facts stated the Florida East Coast was bound to furnish Mrs. Houston reasonably safe facilities for leaving the train and to remain in the station but unless said company or its agents were in some way responsible or could have foreseen and prevented the accident, it cannot be held responsible for injury caused by the negligent act of a third person. In this case, the L. and N. Railway was the third person and we think was responsible for the accident. It was in no way attributable to the negligence of petitioner nor do we know of any criterion by which it could have been put on notice of it. It had not happened before and the character of it was of such a nature that it could not have been reasonably foreseen.’ [c]

Therefore, in *Hall v. Seaboard Air Line Ry. Co.* and *Kenan v. Houston*, supra, the rule may be generally stated that a carrier is liable for injury to its passenger caused by a fellow passenger or a third party if such injury by its nature could have been ‘reasonably anticipated’ or ‘naturally expected to occur’ or ‘reasonably foreseen’ in time to have prevented the injury. (84 Fla. 9, 93 So. 157.) If the injury could have been reasonably anticipated in time to have prevented its occurrence, the carrier is subjected to the highest degree of care to its passenger either to protect him from or to warn him of the danger.⁸⁴

It was impossible for the driver to have protected the Bullocks from Poppell’s assault after his intent became evident, but we think that the district court was clearly erroneous in holding that Tamiami could not have reasonably anticipated or foreseen the danger to the Bullocks in time to have at least warned them of its imminence. We can visualize no stronger case than this to show a situation where two bus drivers and the bus company officials should have reasonably anticipated that mischief was hovering about and that the Bullocks were in some danger.

The first driver testified that many people in West Florida would not approve of the Bullocks’ being seated together toward the front of the bus. Driver Cunningham stated that there would have been less chance of trouble if the Bullocks had been sitting in the back. The first driver, after explaining to a complaining passenger that he could not move the Bullocks, heard another passenger say something like ‘they probably will move on down the line.’ Both drivers had actual notice of the two Company bulletins dated January 31, 1953, and January 23, 1956, the latter plainly warning the drivers of possible racial disturbances.⁸⁵ Certainly, the first driver *332 and, no doubt, Cunningham knew the Bullocks were Jamaicans and British Nationals, and it is logical to infer that the drivers knew the Bullocks were not experienced with ‘southern tradition.’ All of the appellee’s witnesses testified that this was the first instance they knew of in that part of the country where a Negro man and a seemingly white woman were seated together on a public carrier.

Furthermore, this Court will take judicial notice (as the district court should have done) of the commonly and generally known fact that the folkways prevalent in Taylor County, Florida, the county

⁸⁴ See, 10 Am. Jur., Carriers, §§ 1453-1470; [cc] A.L.I., Restatement of Torts, § 348. The duty to warn is identical to the duty to protect. See *Rose v. City of Chicago*, 317 Ill. App. 1, 45 N.E.2d 717.

⁸⁵ ‘Under No Circumstances Shall Police Authorities Be Summoned If A Passenger Refuses A Seating Or Reseating Request. Should Any Disturbance Arise, Police Authorities May Be Summoned To Quell Such Disturbance.’

seat being Perry, would cause a reasonable man, familiar with local customs, to anticipate that violence might result if a Negro man and a seemingly white woman should ride into the county seated together toward the front of an interurban bus.⁸⁶

The next question is whether or not Tamiami, so charged with a duty of foreseeing danger to its passengers, took proper precautions to avoid such danger by the ‘utmost care and diligence of very cautious persons.’ We think that Tamiami failed to exercise this care in several ways. It should have instructed its agency in Jamaica to advise Negroes applying for passage through the southern part of the United States of the South’s tradition of segregation. It should⁸⁷ have instructed its driver to advise Negroes who were obviously foreigners, here known to be such, of segregation customs. The driver should have explained to the Bullocks his reasons for wanting them to move. Above all, the driver should not, either willfully or negligently, have informed the assailant of the Bullocks’ position on the bus and of their apparent color and lack of color.

The district court found, at least impliedly, that Tamiami was not guilty of any willful or aggravated misconduct justifying the imposition of punitive damages, and to that extent its finding is not clearly erroneous. Upon the present record, however, we conclude that the danger should reasonably have been foreseen by Tamiami in time to act with the utmost care to avoid injury to its passengers, particularly by warning them and by not doing foolish things to increase their danger, and that Tamiami breached the duty owed to its passengers, the appellants. The judgment is therefore reversed and the cause remanded with directions⁸⁸ to enter judgment for each of the plaintiffs, appellants, and upon the evidence contained in this record, to award each of them reasonable compensatory damages, including damages for physical injury and mental suffering and humiliation.⁸⁹

Reversed and remanded with directions.

Note 1. Reading the assailant’s testimony included in the court’s footnote makes his culpability unmistakable. He boarded the bus—despite having his car with him—only after learning from the bus driver that a supposedly interracial couple was on the bus and not following the rules regarding where on the bus they were allowed to sit. He didn’t give the Bullocks notice or a chance to move. He bought a ticket expressly in order to pick a fight that had been as much as invited by the bus driver. The court treats the assailant’s actions as intentionally tortious and the bus driver’s conduct as negligent (“not guilty of any willful or aggravated misconduct justifying the imposition of punitive damages”). Do you agree? Based on your study of the intentional torts and requisite intent levels, at what point should the bus driver, too, be deemed to have participated or spurred on Poppell? What facts, if any, convert the driver’s conduct from unreasonable to intentional?

Note 2. Judicial Method, Rhetoric and Tone. On certain fact patterns in which an obvious wrong has been committed, it can be easy to feel intuitively frustrated by the law’s slow analytic process of

⁸⁶ In *United States ex rel. Goldsby v. Harpole*, 5 Cir., 1959, 263 F.2d 71, 82, this Court said: ‘* * * The Supreme Court of Mississippi has said that, ‘We have the right to make use of knowledge of the popular and general customs of the people of this State, and public conditions therein.’ *Moore v. Grillis*, 1949, 205 Miss. 865. A like authority and duty is vested in this Court.’ Citing, *City of Hughes Springs, Tex. v. Lips*, 5 Cir., 1941, 118 F.2d 238; *Rogers v. Douglas Tobacco Board of Trade*, 5 Cir., 1957, 244 F.2d 471, 478; *Mays v. Burgess*, 1945, 79 U.S.App.D.C. 343; 20 Am. Jur., Evidence, Sec. 108.

⁸⁷ *Pelot v. Atlantic Coast Line R. Co.*, 1911, 60 Fla. 159.

⁸⁸ See 28 U.S.C.A. § 2106.

⁸⁹ See *Atlantic Greyhound Lines v. Lovett*, 1938, 134 Fla. 505, 184 So. 133, 140.

following particular steps in formal analysis. To what extent is “formalist” analysis appropriate when actions are so plainly discriminatory? Should the law be permitted to focus on function over form in cases in which significant dignitary rights are at stake? If so, what contexts seem to you to be appropriate? What responsibilities does a court have to identify when conduct goes well beyond the acceptable? If we assumed the substance of the outcome were the same in 2021 as it was back in 1959, how would the rhetoric of this court sound, do you think? Often, contemporary courts use a tone that seems to aspire to “colorblindness” rather than expressly calling out dynamics of race. Why might this be the case? Should this change? Why or why not, and how so?

Note 3. One of the leading scholars on questions of race and gender in tort law has written that the doctrinal reasoning in *Bullock* reflects the race politics of its era:

The duty of the carrier, then, was specific to that time and place, and was specifically based on anticipating racist attacks. All of the bus company’s witnesses stated that this was the first time they knew of a black man and a white woman sitting together on a bus or train in that region. The attacks should have been anticipated, not simply because a black person was sitting in the front of the bus, but because the combination of “a Negro man and a seemingly white woman” sitting together in the front was obviously incendiary. The Fifth Circuit recognized this as a risk-creating combination of people, space, and circumstances. By contrast, the trial court ignored the volatile gender-race confluence and saw this assault as a fluke, as unforeseeable, and therefore something for which the bus company should not be liable. ... To the trial court, the harm was unforeseeable, and thus the company had no duty to prevent it. [***] Both views about duty and foreseeability of risk are dependent on opposing empirical conclusions drawn by courts. Jennifer B. Wriggins, *Toward A Feminist Revision of Torts*, 13 Am. U. J. Gender Soc. Pol’y & L. 139, 150-151 (2005) (internal citations omitted).

It is somewhat difficult to reconcile these different perceptions of foreseeability without reference to the historical context and the particular social context of each court. Relatedly, what do you make of the lower court’s statement that it is bound, descriptively, by the law it must follow: “Without regard to the views of this Court as to what the law should be in such a case as this the decision of this Court is completely controlled by the decision of the Supreme Court of Florida in the case cited above.”

How does it square with the appellate court’s response: “We are not in agreement with the district court either as to the Florida law or as to the ultimate facts, inferences or conclusions of duty and breach of duty on the part of the appellant carrier”?

Throughout this book, we have distinguished *descriptive* and *normative* accounts of law. Are there instances in which we ought to *expect* these two categories may blur? Does this blurring suggest that entrenched structural racism is a symptom of our legal system or a byproduct, or are there other possibilities for how the courts interpret the law here?

Note 4. The context of the case may seem to make its facts exceptional. However, plaintiffs continue to bring lawsuits charging common carriers with breach of duty to provide safe passage. In an era in which racial tensions have been heightened nationally for several years and many people rely on public transportation to get to their schools and jobs, what scope of duty do you think is appropriate for common carriers? Not all jurisdictions retain a heightened duty; for instance, New Jersey does so though New York imposes only a reasonable a duty of care. How far should common carriers be

expected to go when unruly or dangerous passengers begin to make trouble for other passengers? Recall the foreseeability analysis of *Walls v. Oxford Management*.

Could the reasoning from *Walls* be applied in this context? A recent case suggests judicial willingness to hold such defendants to account even for conduct by third parties. The attacks on the passenger are violent and ugly in nature, and the court considered the policy issues explicitly and with laudable nuance. Consider as you read this excerpt of the case whether gender, race, class and age are likely to have played any role in the facts or in judicial analysis of the facts.

**Maison v. New Jersey Transit Corporation, Supreme Court of New Jersey
(2021)
(245 N.J. 270)**

[***] Every day, throughout this state, thousands of people take buses and trains to commute to work, visit family and friends, and travel to vacation spots. Those modes of transportation are known as common carriers. Passengers pay fares to common carriers to safely transport them to their destinations. Under the common law, privately owned carriers owe their passengers a heightened duty of care to act with the utmost caution to protect them, even from the wrongful acts of co-passengers – a duty to act as would a very careful and prudent person in light of the circumstances. [***] In this case, plaintiff Anasia Maison on her commute home from work took an NJ Transit bus. During the ride, a group of four to five teenagers verbally and physically harassed her as the bus driver silently watched and drove on. Despite the escalating threats and unruly behavior toward Maison, the bus driver did nothing – did not call out the teenagers, stop the bus, or contact *275 NJ Transit or the police. As one of the teenagers disembarked, he threw a bottle striking Maison in the forehead, causing a permanent and serious injury.

On July 21, 2013, Anasia Maison, a twenty-year-old college student, was working at a New York City pharmacy until her shift ended at 12:00 a.m. on July 22. On her way back home to Newark, she first took an NJ Transit train to Penn Station in Newark, arriving there at around 1:00 a.m. At Broad and Market Streets, she boarded an NJ Transit bus operated by defendant [bus driver] Coats. She paid her fare and took a seat towards the rear of the bus. Two rows behind her were four to five male teenagers. *277 Maison testified that as soon as the bus pulled away, she was struck on the side of her face by an unknown object “thrown very hard” by one of the teenagers. She turned to them and asked, “why are [you] bothering me?” One of the young men said to his friends that Maison “should ‘f’ one of them up.” A few seconds later, another object was thrown at her, but it hit only the chair. She turned again and asked the young men to stop harassing her. They told her “to shut the f**k up” and loudly hurled insults at her. In response, Maison admittedly used foul language, but the stream of profanities from the young men continued. Maison could see the bus driver, Coats, watching the commotion in his rearview mirror, but Coats kept driving.

When one of the teenagers brandished a knife, Maison said “out loud,” [sic] “I need help.”

Although she could not tell whether Coats heard her, she saw that he was peering at her through his rearview mirror. Frightened, Maison got up and moved toward the front of the bus, but when a passenger told her, “[you] better not come up here,” she returned to her seat where the insults continued

to rain down on her. She tried to make a call from her cell phone, but the signal failed – and the attempted call caught the attention of the youths. A minute or two later, one of the teenagers rang the bell for the bus to stop. As they were leaving through the rear side door of the bus, Maison heard a passenger tell one of them, “don’t do it” – and then, all of a sudden, a bottle struck her in the face. As she bled from the forehead, the youths continued to taunt and threaten her through the open door of the bus.

Maison called out for help, yelling: “I need ambulance. I need police.” Coats remained in his seat. A passenger gave her a cell phone, which she used to call the police and an ambulance. After the ambulance arrived, Maison was transported to Beth Israel Hospital, where she received twenty-two stitches to treat the wound to her forehead – the site now of a permanent scar that has left her self-conscious about her appearance. In the aftermath ***278** of the attack, she suffered from very bad headaches and delayed her college graduation.

In his testimony, Coats recalled that Maison boarded the bus at about 1:14 a.m. and, immediately afterwards, four to five young men entered and took seats behind her. As he drove, he observed through his rearview mirror the young men and Maison “cursing back and forth” – “a lot of b’s and f’s.” [fn] A passenger interceded and said to the young men, words to the effect of, “don’t disrespect her, don’t call her the b word.” According to Coats, Maison “was handling herself very well.” He monitored the situation and knew that there was a threat to Maison. He acknowledged that his job was to get his passengers “from point A to B safely” but also stated in his deposition testimony read to the jury that “it’s not my job to get involved. First of all, my safety comes first.”

Seven to eight minutes into the drive from Broad and Market Streets, where the verbal conflict began, someone pressed the bell for the Hayes Circle stop. Arriving there, Coats opened the front and rear doors, and then he heard “a smack,” “glass breaking,” and “Maison screaming.” He looked back and saw that Maison had been hit and was bleeding profusely and that a passenger was consoling her. Coats got up, observed the shattered pieces of a liquor bottle on the ground and seats, and asked if she wanted an ambulance or the police. She “screamed,” “yes.”

Coats, however, did not call directly for an ambulance or the police. He followed NJ Transit’s procedure and pushed a button to call NJ Transit’s control center. Coats waited for about fifteen minutes before the control center returned his call. The control center then contacted the police and emergency medical services. Coats did not believe that NJ Transit policy permitted him to use his cell phone to contact first responders.

***279** Coats stated that he never observed the young men throw objects at Maison or flash a knife, never heard Maison call out to him, and never saw her get out of her seat. He admitted that he monitored the situation in the rear of the bus during the seven- to eight-minute ride to Hayes Circle and that he did not stop the bus, tell the young men to “knock it off,” call the police, or contact NJ Transit’s control center until after Maison was hit with the bottle.

The police never apprehended the young men who tormented and assaulted Maison. [***]

[The bus driver attempted at trial to state that he had merely been enforcing the law. A footnote calls that into question] “The court asked defendants’ counsel what law the bus driver was “executing or enforcing.” He responded, “[c]andidly I’m at a loss to articulate one.””

[***] The jury was charged on the law applicable to common carriers, as set forth in Model Jury Charges (Civil), 5.73(A)(2), “Carriers for Hire” (approved June 1988). The court instructed the jury that

[a] common carrier must exercise a high degree of care to protect its passengers from dangers that are known or reasonably foreseeable. Carriers must use the u[t]most caution to protect their passengers. The kind of caution that is characteristic of a very careful and prudent person. A carrier must act with the highest possible care consistent with the nature of the undertaking involved. This includes the duty to protect passengers from wrongful acts of co-passengers if the u[t]most care could have prevented those acts from injuring a passenger.

If a danger was known or reasonably could have been anticipated[,] the carrier has a duty to protect its passenger from any injury that could be caused by that danger.

280** The jury returned a verdict finding both NJ Transit and Coats liable. The jury also found that Maison sustained a permanent disfigurement from her injury and awarded her \$1,800,000 in damages. [] The Appellate Division affirmed in part and reversed in part, remanding for a new trial only on the allocation of fault between the bottle thrower and defendants. [fn] [cc] The Appellate Division concluded that the trial court correctly held NJ Transit to “the common carrier standard of negligence” and observed that “our case law has viewed bus lines generally, and public transit systems specifically, as common carriers for many years.” [***]

Last, the Appellate Division determined that the trial court erred in not placing the bottle thrower on the verdict sheet to allow for the allocation of fault among the tortfeasors. [c] [W]e affirm the Appellate Division, including its determination that the damages award should stand and that the new jury should not be informed about the amount of the award.

Note 1. The court reasons that “If a danger was known or reasonably could have been anticipated[,] the carrier has a duty to protect its passenger from any injury that could be caused by that danger.” Is this merely following the scope and logic of *Tarasoff* or does it expand upon that earlier case?

Note 2. What does it mean to “plac[e] the bottle thrower on the verdict sheet,” both practically and legally?

Note 3. The court ruled that the damages award stands and the jury should not be informed of the amount. Why? What does the court presume may happen? What concerns are animating this decision to let the award stand but also to allow its potential reallocation?

Duties Related to Premises Liability

Special rules that vary by jurisdiction and circumstance define the duties of possessors of land to those who enter it, as illustrated above in the Restatement’s Section 314A. Most jurisdictions follow the traditional rule at common law and **determine the duties of possessors of land based on the status of the entrant**: a trespasser, a licensee, or an invitee. The distinctions among duties of care owed to these three categories of entrants arose due to the social hierarchy of the feudal system: medieval landowners held land and were thought to deserve the right to enjoy it without concern for protecting

against injury to those who entered their land without permission. William Prosser, *Law of Torts* 359 (4th ed. 1971).

Roughly 22 jurisdictions have either abolished or modified the status-based system, by judicial decision or statute or both. Most of these follow a landmark ruling in California that paved the way for the modern approach, which mandates that **a duty of reasonable care is owed to all entrants regardless of status** but applies a series of factors that particularize the duty further.

Note that for our purposes, “owners,” “possessors” and “occupiers” of land are used interchangeably and courts and legislatures take varying approaches on whether they use one or more of the terms. The primary point for you to take from that is that a person need not *own* property to be liable for harm that occurs on it, if they are otherwise the possessor or occupier of that property. (Usually a possessor means the person presently permitted to be there, such as a renter or long-term guest; an occupier is the person who is presently inhabiting the premises whether or not they have a legal right to do so).

Traditional Status-Based Approach. Idaho, whose slip-and-fall case, *McDonald v. Safeway*, is assigned in Module 3 (under Circumstantial Evidence), sets out the following rules:

(1) **Invitees** are owed the **highest duty of care** in premises liability, and there are two avenues for a plaintiff to establish that he is an invitee. ... A plaintiff can establish that he was on the premises “for a purpose connected with the business conducted on the land,” or show that “it can reasonably be said that the visit may confer a business, commercial, monetary or other tangible benefit to the landowner.” [c] *Dupuis v. E. Idaho Health Servs., Inc.*, No. 47917, 2021 WL 1416551, at *5 (Idaho Apr. 15, 2021)

(2) **A licensee** is a visitor who goes upon the premises of another **with the consent of the landowner** in pursuit of the visitor’s purpose.” [c] *Id.*

This means that in Idaho, a landowner owes an invitee the duty **to keep the premises in a reasonably safe condition and or to warn the invitee of any concealed or hidden dangers**. Often, litigation centers on whether the landowner knew or should have known of a particular risk. A second issue that arises with some frequency is whether the invitee exceeded the scope of their permitted access. For instance, if a customer in a grocery store sneaks into the back room to use the employee restroom and trips over a carelessly placed mop, the customer may be treated not as an invitee but as a licensee or possibly a trespasser (both the facts and the specific jurisdiction’s case law matter to the analytical outcome).

Correspondingly, in Idaho, a property owner owes a licensee the duty to **share knowledge of dangerous conditions or activities on the land**, usually through warning signs or some other means of putting entrants on notice. This duty specifies a lower standard of care to a licensee than to an invitee; the land owner need not *fix* a dangerous condition with respect to a licensee’s presence on their premises but must merely warn of it once it is discovered (under a subjective standard called “actual knowledge”) or ought to have been discovered by the owner (under an objective standard sometimes called “constructive knowledge”). The distinction between the first two categories, then, is that **invitees are people whom a business invites onto their premises** as part of its provision of services or goods; invitees are analogous to customers. **Licensees** are those who are **merely permitted to be on the premises**, more like guests or visitors. The rationale for the higher standard of care

towards invitees is that the owner is seeking to profit off the invitee's presence on their premises and thus the invitee ought to be able to expect reasonable efforts to make the premises safe.

(3) If entrants on land are neither invitees nor licensees, they are typically classified as **trespassers**:

Any one who goes upon the private property of another without lawful authority or without permission or invitation, express or implied, is a **trespasser to whom the landowner owes no legal duty until his presence is discovered**. He is only required to **refrain from wanton or wilfull [sic] acts which occasion injury**. *Bicandi v. Boise Payette Lumber Co.*, 55 Idaho 543, 44 P.2d 1103, 1106 (1935)

Owners of land owe trespassers the lowest duty, given the basic principle that such entrants are neither invited nor permitted to enter. Indeed, it is possible owners neither know nor have reason to know that such entrants are present. However, "once the presence of the trespasser becomes known or reasonably could have been anticipated, the land owner has a duty not to injure the trespasser by any intentional or reckless act. [***] This standard of conduct prohibits the owner from engaging in 'intentional or reckless actions, taken under circumstances where the actor knew or should have known that the actions not only created an unreasonable risk of harm to another, but involved a high degree of probability that such harm would actually result.'" *Mowers v. Union Pac. R.R. Co.*, No. 4:16-CV-00177-CWD, 2016 WL 6246301, at *3 (D. Idaho Oct. 25, 2016)(citations omitted)

Idaho's rules are representative of the common law rules and the majority of jurisdictions retain the "tripartite" system of classifying duties according to the status of the entrant.

Modern Approach. In *Rowland v. Christian*, plaintiff James Rowland was a guest in defendant Nancy Christian's apartment. When he used the bathroom faucet, the porcelain handle broke, causing serious injury to his hand which included severing tendons and nerves and which led to Rowland's incurring \$100,000 in general damages. It did not appear that the crack in the handle was obvious to ordinary inspection or concealed although Rowland had used the sink before. Christian knew for two weeks that it was broken and had asked the landlord to repair it but failed to warn Rowland. Students often wonder why a guest would sue their host and whether other defendants were not available. First, duties of "possessors" of land reach more broadly than owners; as a renter, Christian had certain duties that were distinct from those of the landowner. Second, the Supreme Court's opinion does not clarify that the two did not know each other well, a fact that was included in the appellate court's opinion. They were introduced through a mutual friend and Christian had agreed to drive Rowland to the airport so he could board a plane. For reasons the record does not divulge, either she invited him to her apartment beforehand and he was injured using the bathroom while waiting for the defendant to get ready for the drive to the airport, or he appeared at her apartment to ask for a ride. (The facts appear contested on this point.) The time he injured his hand was not the first time using the faucet but the record does not contain many more clues beyond that. The trial court granted summary judgment and the appellate court somewhat reluctantly affirmed, noting that on the record it did not believe it could change the law but implying its desire to do so. ("We are mindful of the criticisms directed at the California rule. [c] In the present case, however, the scope of our review is defined by the rules applicable to summary judgments. Acting within a context thus limited, we have concluded that substantive law cannot be changed on the narrow evidentiary base presented by this record." *Rowland v. Christian*, 63 Cal. Rptr. 98, 104 (Ct. App. 1967)).

The appellate court's analysis focused on whether a known condition such as a broken faucet handle was analogous to a trap since the "trap exception" could give rise to a duty to warn entrants on land and in some cases a duty to remedy or "protect" them. Its analysis reflects a formalistic emphasis on remaining within the contours of existing law. The Supreme Court took a different tack, treating the case as a paradigmatic example of the fundamental principle that everyone has a duty to refrain from causing harm to others. A civil statute in California had long codified that rule, lending further support for the court's reasoning.

It's worth noting that one of the leading proponents of the modern view of generalized duty, William Lloyd Prosser, was the Dean of UC Berkeley's law school from 1948-1961 and then a professor at UC Hastings Law School. He was a venerated jurist nationally as well as in California in particular. Through his treatise, textbook and massive contributions to the Restatements on Torts, he directly or indirectly shaped the views of many students, practitioners, professors and judges. It is hard to overstate his influence on tort law (then and now). Recall that at early common law, the general rule was *no* duty absent contract, privity or some other justification for creating an affirmative duty. From Prosser's reformulated approach to duty—that everyone had a general duty unless some exception existed—the *Rowland* court could argue that the tripartite system of status-biased duties effectively created a set of immunities that reduced the general duty. Under the old view of duty, the tripartite system could be cast as *adding* or *creating* duties rather than *limiting* them. This new reading inverted that description of duties and immunities. This inversion is key to understanding the revolution *Rowland* brought about.

Rowland identified factors to consider in permitting a departure from the general duty rule and then pointed out how the status of the entrant was not dispositive in analyzing those factors. It cast the traditional system of defining limited duties as linked to historic rationales that had grown outdated:

The ordinary justification for the general rule severely restricting the occupier's liability to social guests is based on the theory that the guest should not expect special precautions to be made on his account and that if the host does not inspect and maintain his property the guest should not expect this to be done on his account. [c] An increasing regard for human safety has led to a retreat from this position, and an exception to the general rule limiting liability has been made as to active operations where an obligation to exercise reasonable care for the protection of the licensee has been imposed on the occupier of land. *Id.* at 114, 565.

Clearing away "the ancient concepts as to the liability of the occupier of land" and applying standard negligence analysis, it reversed the grant of summary judgment. The court held that because Christian appeared to be aware that the faucet handle was dangerous and had failed to warn or remedy, her behavior constituted negligence. The court reasoned as follows: "Whether or not a guest has a right to expect that his host will remedy dangerous conditions on his account, he should reasonably be entitled to rely upon a warning of the dangerous condition so that he, like the host, will be in a position to take special precautions when he comes in contact with it." *Id.* at 120.

Even in the jurisdictions that have abandoned or modified status-based duties, subsequent courts often refer to the "*Rowland* factors" in analyzing the duties of possessors of land. Consequently, courts end up continuing to make some distinctions among entrants along factually nuanced, if not categorical lines. *See Perez v. S. Pac. Transportation Co.*, 218 Cal. App. 3d 462 (Ct. App. 1990) ("The status of a claimant at the time of his injury no longer affects the general duty of the possessor of property to

exercise ordinary care with respect to reasonable foreseeable risks of personal injury to persons coming on the property. The possessor's duty of ordinary care extends to invitees and trespassers alike, although the foreseeability of injury, and hence the degree of care required of a possessor, continues to be influenced by the likelihood that persons will be present on the property at a particular time and place, a likelihood normally considerably greater for invitees than for trespassers.")

Given tort law's propensities for fact-sensitive adjudication, can you see why? Cutting against that, since duty is ordinarily a question of law, not fact, is the modern view introducing unnecessary complexity in the form of these factual, rather than categorical inquiries?

A departure from this fundamental principle involves the balancing of a number of considerations; the major ones are (1) the foreseeability of harm to the plaintiff, (2) the degree of certainty that the plaintiff suffered injury, (3) the closeness of the connection between the defendant's conduct and the injury suffered, (4) the moral blame attached to the defendant's conduct, (5) the policy of preventing future harm, (6) the extent of the burden to the defendant and (7) consequences to the community of imposing a duty to exercise care with resulting liability for breach, and (8) the availability, cost, and prevalence of insurance for the risk involved. *Rowland v. Christian, supra*, 69 *Cal.Rptr.* 98, 112–113. [enumeration added]

Which approach seems more sound, in your view, the status-based system of duties or a general duty informed by the *Rowland* factors? What do these factors add that is not already involved in duty analysis?

Expand On Your Understanding – Taco Bell Hypothetical

Duties Owed to Business Invitees in Traditional-Rule Jurisdictions

In these jurisdictions, business owners who profit from “invitees” coming onto their property owe those invitees a higher duty of care. But how high? A man entered a Taco Bell store to buy a soft drink. As he was paying, he suddenly fell backward, was knocked unconscious and began having a seizure. At trial, it was disputed whether or not the customer, Baker, received any help from Taco Bell after he came to. The employee claims she offered assistance and Baker stated that he did not need an ambulance. Baker then stood up and fell again, once again became unconscious, knocked out his four front teeth and cracked the seventh vertebra of his neck. When he regained consciousness, he was choking on the blood and teeth in his mouth. He stumbled out of the store and was able to get help elsewhere.

Question 1. Is a customer who has a seizure on a business’s premises owed a duty of reasonable care with respect to foreseeable harms? Descriptively? Review the language of Restatement § 314A, above.

An interactive H5P element has been excluded from this version of the text. You can view it online here: <https://saidtorts2d.lawbooks.cali.org/?p=55#h5p-60>

Question 2. How about normatively? What arguments would you offer in support of your views?

An interactive H5P element has been excluded from this version of the text. You can view it online here: <https://saidtorts2d.lawbooks.cali.org/?p=55#h5p-61>

Check Your Understanding (3-2)

Question 1. *Rowland* states that “the exceptions to those immunities, often do not reflect the major factors which should determine whether immunity **should** be conferred upon the possessor of land.” *Rowland v. Christian*, 69 Cal. 2d 108, 116 (1968).

True or false: The word “should” here is normative, not descriptive.

An interactive H5P element has been excluded from this version of the text. You can view it online here: <https://saidtorts2d.lawbooks.cali.org/?p=55#h5p-62>

Reflect On Your Understanding – *Rowland v. Christian*

Compare the two rationales offered below, drawn from *Rowland*'s majority and dissenting opinions. Which do you find more persuasive? Who is most likely to be better served by the arguments in each opinion? How does each serve or disserve the purposes of tort law?

(1) *Rowland v. Christian*, 69 Cal. 2d 108, 118 (1968) **Majority opinion:** “A man’s life or limb does not become less worthy of protection by the law nor a loss less worthy of compensation under the law because he has come upon the land of another without permission or with permission but without a business purpose. Reasonable people do not ordinarily vary their conduct depending upon such matters, and to focus upon the status of the injured party as a trespasser, licensee, or invitee in order to determine the question whether the landowner has a duty of care, is contrary to our modern social mores and humanitarian values. The common law rules obscure rather than illuminate the proper considerations which should govern determination of the question of duty.”

(2) *Rowland v. Christian*, 69 Cal. 2d 108, 120 (1968) **Dissent:** In determining the liability of the occupier or owner of land for injuries, the distinctions between trespassers, licensees and invitees have been developed and applied by the courts over a period of many years. They supply a reasonable and workable approach to the problems involved, and one which provides the degree of stability and predictability so highly prized in the law. The

unfortunate alternative, it appears to me, is the route taken by the majority in their opinion in this case; that such issues are to be decided on a case by case basis under the application of the basic law of negligence, bereft of the guiding principles and precedent which the law has heretofore attached by virtue of the relationship of the parties to one another.

Liability for negligence turns upon whether a duty of care is owed, and if so, the extent thereof. Who can doubt that the corner grocery, the large department store, or the financial institution owes a greater duty of care to one whom it has invited to enter its premises as a prospective customer of its wares or services than it owes to a trespasser seeking to enter after the close of business hours and for a nonbusiness or even an antagonistic purpose? I do not think it unreasonable or unfair that a social guest (classified by the law as a licensee, as was plaintiff here) should be obliged to take the premises in the same condition as his host finds them or permits them to be. Surely a homeowner should not be obliged to hover over his guests with warnings of possible dangers to be found in the condition of the home (*e.g.*, waxed floors, slipping rugs, toys in unexpected places, etc., etc.). Yet today's decision appears to open the door to potentially unlimited liability despite the purpose and circumstances motivating the plaintiff in entering the premises of another [***].

In my view, it is not a proper function of this court to overturn the learning, wisdom and experience of the past in this field. Sweeping modifications of tort liability law fall more suitably within the domain of the Legislature, before which all affected interests can be heard and which can enact statutes providing uniform standards and guidelines for the future.

Duties to Children. Landowners may owe children special duties, even when they trespass. The (best-ever-named) doctrine of **Attractive Nuisance** sets out specific duties to safeguard one's land against known attractions and risks.

Restatement 2d Section 339 – Artificial Conditions Highly Dangerous to Trespassing Children – A possessor of land is subject to liability for physical harm to children trespassing thereon caused by an artificial condition upon the land if:

- (a) the place where the condition exists is one upon which the possessor **knows or has reason to know that children are likely to trespass, and**
- (b) the condition is one of which the possessor knows or has reason to know and which he **realizes or should realize** will involve an **unreasonable risk of death or serious bodily harm** to such children, **and**
- (c) the children *because of their youth* **do not discover the condition or realize the risk** involved in intermeddling with it or in coming within the area made dangerous by it, **and**

- (d) (d) **the utility** to the possessor of maintaining the condition and **the burden of eliminating** the danger are slight as compared with the **risk to children involved**, and
- (e) (e) the possessor fails to exercise reasonable care to eliminate the danger or otherwise to protect the children.

Under the attractive nuisance doctrine, trespassing children have the burden of proving that they did not anticipate the danger when entering the property; it is the expectation that their immaturity will make it difficult for them to understand the risk that justifies the doctrine. Otherwise, it will be assumed that they are ordinary trespassing thrillseekers who understood the risk and proceeded anyway. The plaintiff must also prove that it was feasible for the landowner to eliminate the dangerous condition. This may not mean removing something dangerous but it may require boarding it up or taking other steps to repair or limit access. The cases originally arose to protect children playing on railroads but the fact patterns have involved swimming in unbarricaded water or pools, diving from various structures, and other activities involving unsecured machinery.

Summary of Duties of Owners and Possessors of Land—Majority and Minority Approaches		
Traditional “Tripartite” Approach (majority approach)	Status of Entrant	
	Business Invitee	Duty to keep the premises in a reasonably safe condition and or to warn the invitee of any concealed or hidden dangers
	Licensee	Duty to warn of dangerous conditions or activities on the land
	Trespasser	Duty not to intentionally injure (e.g. through traps or spring guns). No duty until trespasser’s presence is discovered or reasonably ought to have been discovered; then a duty to refrain from wanton and wilful conduct that could injure trespasser; in some jurisdictions, also a duty to warn of latent or hidden defects.
	Children	Duty to exercise reasonable care to eliminate dangerous conditions creating extraordinary risks of harm to children (“attractive nuisance doctrine”)
Modern Approach (CA)	All Entrants	Duty of reasonable care
	Children	Duty of reasonable care

Duties That Specify Particular Conduct

Implicit in discussions of duties owed to children and to specific classes of entrants under the traditional approach is that, in some instances, determining whether a duty exists and the standard of care it requires become interdependent questions. Put another way, in the area of limited duties, **duty is sometimes articulated as a duty to do a specific thing**—that is, as **an act-centered kind of duty** rather than a purely relational one.

Discussions of limited duty will often entail some specification of the standard of care or specific acts. Given this, you might consider whether such duty determinations should be shifted to the jury as a question of fact or retained for determination by the judge as duty questions usually are. One justification for retaining them as a question of law is that whole classes of actors may be similarly situated. Do Taco Bell and restaurants like it owe a duty *to take particular steps* to its business invitees? Do Carnival and other cruise ship operators owe a duty *to take particular steps* to keep customers on its cruises safe? In the next case, Carnival may have had a duty *to do X* with respect to Ms. Carroll but *not a duty to do Y*. Either way, it is beyond doubt that Carnival did have a duty to Ms. Carroll; the question is what that duty required of Carnival.

Carroll v. Carnival Corporation, U.S. Court of Appeals, Eleventh Circuit (2020) (955 F.3d 1260)

Elaine Carroll tripped over the leg of a lounge chair while she was walking through a narrow pathway on a Carnival cruise ship. She sued Carnival, alleging that it negligently failed to maintain a safe walkway and failed to warn her of that dangerous condition. The district court granted summary judgment in favor of Carnival on both claims, concluding that the condition was open and obvious and that Carnival lacked actual or constructive notice of the hazard. After review of the record and the parties' briefs, and with the benefit of oral argument, we reverse. ***

In March of 2015, Mrs. Carroll and her husband Michael were passengers on board the *Carnival Pride*. On the first full day of the cruise, Mrs. and Mr. Carroll *1263 were walking to one of the restaurants, David's Steakhouse, on Deck 11 of the ship. The outer glass wall of David's Steakhouse is curved in the shape of a semi-circle. Lounge chairs are set up in a semi-circular shape along the curved glass wall of the restaurant.

To get to the restaurant, the Carrolls had to walk on a curved walkway between the foot-end of the row of lounge chairs (on their right side) and the ship's railing (on their left side). When they initially approached the walkway, there were approximately two to three feet between the chairs and the railing, so they were able to walk side-by-side. At some point after passing the first chair, however, the distance between the chairs and the railway narrowed, so Mrs. Carroll's husband walked in front of her and she followed behind him. While Mrs. Carroll was walking behind her husband, her right foot clipped the leg of one of the lounge chairs, causing her to fall and suffer injuries.

Mrs. Carroll sued Carnival for negligence. She asserted, among other things, that Carnival negligently maintained a dangerous condition—“lounge chairs that narrowed and protruded onto a pedestrian walkway”—and negligently failed to warn passengers of the danger associated with that condition. Carnival moved for summary judgment, arguing that the lounge chairs did not constitute a dangerous condition, and even if they did, it had no duty to warn of the condition for two reasons. First, the condition was open and obvious. Second, Carnival lacked notice of the hazard. Mrs. Carroll opposed the motion, responding that although the lounge chair that she tripped on was not hazardous in and of itself, the location of the lounge chairs and the manner in which they were arranged constituted a dangerous condition. She also argued that the condition was not open and obvious because, due to the layout of the lounge chairs and the narrowness of the path, she was forced walk behind her husband, obstructing her view. And she asserted that she did not need to prove that Carnival had notice of the hazard because it created the unsafe condition.

Both parties presented evidence in support of their positions, including the deposition testimony of Mrs. and Mr. Carroll and several Carnival employees. Mrs. Carroll also presented the affidavit of an expert, Randall Jaques, who opined that the walkway was unsafe and fell below industry standards.

[The district court granted Carnival’s motion for summary judgment, concluding that Carnival lacked notice of the danger but need not reach that issue because it found that Carnival had no duty warn Mrs. Carroll of the allegedly dangerous condition because it was open and obvious]. [***]

***Mrs. Carroll had to prove that (1) Carnival had a duty to protect her from a particular injury; (2) Carnival breached that duty; (3) the breach actually and proximately caused her injury; and (4) she suffered actual harm. [c] With respect to the duty element, a cruise line like Carnival owes its passengers “a ‘duty of reasonable care’ under the circumstances.” *** We begin by analyzing Mrs. Carroll’s claim that Carnival negligently failed to warn her of a dangerous condition, and then evaluate her claim that Carnival negligently failed to maintain a safe walkway. *** The question, therefore, is whether a reasonable person would have observed the chair leg and appreciated the risk of walking through the narrow passageway under the circumstances. [fn]

The district court concluded that Carnival had no duty to warn Mrs. Carroll of the dangers associated with the walkway because the “placement of deck chairs on an open deck, on a clear and sunny day, was an open and obvious condition.” In reaching this decision, the *1265 district court relied on Mrs. Carroll’s deposition testimony that she could have seen the chair leg had she looked down. The district court also relied on Mrs. Carroll’s testimony “that she did not walk behind her husband because the area narrowed, as her husband explained, but rather, because ‘you do that.’” But there was also evidence in the record—which the district court did not acknowledge—that Mrs. Carroll was *forced* to walk behind her husband after passing the first lounge chair because the walkway narrowed. Mrs. Carroll testified that, as a result, her view was blocked by her husband, who has a large profile, so she could not see the foot of the lounge chair that she tripped on nor around the curve of the walkway.

In our view, the district court erred by crediting some statements by Mrs. Carroll—which favored Carnival’s open and obvious argument—over her other statements that she was forced to follow behind her husband due the layout of the chairs and the narrowness of the walkway. Viewing the facts in the light most favorable to Mrs. Carroll, as we must, the record supports an inference that a reasonable person in Mrs. Carroll’s circumstances would not have observed the chair leg obstructing her path. There is a genuine dispute of material fact as to whether the danger associated with the walkway was

open and obvious. After concluding that Carnival had no duty to warn Mrs. Carroll because the allegedly dangerous condition was open and obvious, the district court stated that it need not decide whether Carnival had actual or constructive notice of the condition. It nevertheless determined that Carnival lacked such notice. In reaching this conclusion, the district court again failed to view the evidence in the light most favorable to Mrs. Carroll and overlooked evidence in the record from which a reasonable jury could find that Carnival had notice. [fn]

Evidence that a ship owner has taken corrective action can establish notice of a dangerous or defective condition. *See Guevara*, 920 F.3d at 720–22 (holding that a warning sign alerting passengers to “watch [their] step” was sufficient to create an issue of material fact on whether the cruise ship had notice of the dangerous nature of the step down); *Sorrels*, 796 F.3d at 1288 (holding that a ship employee’s testimony that the ship would sometimes post a warning sign on the pool deck after it rained was enough to create an issue of material fact on whether there was notice that the deck could be slippery when wet). Here, there is evidence reflecting that Carnival took corrective measures to prevent people from tripping over the lounge chairs in the walkway on Deck 11.

***1266** For example, Mrs. Carroll presented evidence, including the testimony of one of Carnival’s employees, that if the lounge chairs were arranged in the “lay-flat position,” rather than upright, they would protrude further into the walkway—making the walkway even narrower. As a result, Carnival required them to be set up in the upright position, and employees regularly patrolled the area to fix the chairs. Specifically, one of Carnival’s pool deck supervisors, Viktor Symotiuk, testified that the lounge chairs on Deck 11 were supposed to be arranged in the upright position, and he was instructed (and trained other employees that he supervised) to make sure that the chairs were not protruding into or blocking the walkway. Although he testified that a lounge chair may be used in the lay-flat position if it is occupied, he also stated that “[y]ou never leave the chair unattended and flat in that area.” He further acknowledged that “[i]f the lounge chair is set on the passenger walkway, it would be an obstruction[], it’s a reason why a person can get injured.”

The district court relied on the deposition of another pool deck supervisor, Denys Stavtys’ky, who testified that that the chairs could be set up in either the upright or lay-flat position. But the conflict in the testimony of Mr. Symotiuk and Mr. Stavtys’ky demonstrates that there is a dispute of material fact, making summary judgment inappropriate.⁹⁰ [***]

As in *Guevara* and *Sorrels*, a reasonable jury could view this testimony as evidence that Carnival has taken corrective measures—i.e., adopting a policy of keeping the chairs in-line and/or in the upright position and instructing employees to ensure that they are not blocking the walkway—due to a known danger. This is enough to withstand summary judgment on the issue of Carnival’s notice.

In sum, there were disputes of fact on both the obviousness of the condition and Carnival’s notice of the danger. The district court therefore erred in granting summary judgment on Mrs. Carroll’s failure to warn claim.⁹¹

⁹⁰ We note that Mr. Stavtys’ky also testified that hotel stewards were required to inspect that the chairs were arranged properly every 15-20 minutes. *See* D.E. 44-3 at 45–46.

⁹¹ Mrs. Carroll also asserts that Carnival had notice of the dangerous condition because there were 12 separate instances where passengers tripped and fell over lounge chairs aboard ships in the same class as the *Carnival Pride*. The parties dispute whether these prior incidents were sufficiently similar to Mrs. Carroll’s accident to put Carnival on notice of the risks associated with the walkway on Deck 11 of the *Carnival Pride*. We do not reach this issue

The district court appears to have concluded that Carnival was entitled to summary judgment on both Mrs. Carroll's failure to warn and negligent maintenance *1267 theories because of the open and obvious nature of the condition. The district court reasoned that it need not reach notice after determining that the condition was open and obvious, suggesting that its decision on the latter was dispositive of the entire case. That initial conclusion, however, should not have ended the analysis for Mrs. Carroll's negligent maintenance claim.

As Mrs. Carroll correctly argues, Carnival may still be liable for maintaining a dangerous condition even if the danger was obvious. The open and obvious nature of a dangerous condition negates liability for failure to warn. *** We have not squarely addressed, however, whether the open and obvious nature of a dangerous condition also bars liability for a maritime negligent maintenance claim. *** Thomas J. Schoenbaum, *Admiralty & Maritime Law* § 5:11 (6th ed. 2018) (“[T]here is a duty to warn passengers only of dangers that are not apparent and obvious. [The court concludes that the open and obvious nature of a dangerous condition does not bar a claim against a shipowner for negligent failure to maintain safe premises.]

Mrs. Carroll presented evidence creating a genuine dispute of material fact as to whether Carnival negligently maintained an unsafe walkway. This included an affidavit from her expert, Mr. Jaques, who opined that the width of the walkway would have been below industry standards if the chairs were in the lay flat position. This testimony is relevant in determining whether Carnival's conduct fell below the standard of care. *See, e.g., Sorrels*, 796 F.3d at 1282 (“[E]vidence of custom within a particular industry, group, or organization is admissible as bearing on the standard of care in determining negligence ... Compliance or noncompliance with such custom, though not conclusive on the issue of negligence, is one of the factors the trier of fact may consider in applying the standard of care.”) (citation and internal quotation marks omitted).

According to Mr. Jaques, the maximum amount of room possible in the walkway was 35–36 inches if the lounge chairs were in the upright position and pushed up against the glass wall of David's Steakhouse. If the lounge chairs were in the lay-flat position, however, the width of the walkway would be 28 ½ inches if the chairs were only two inches from the glass, and between 23 and 25 inches if the chairs were approximately six inches from the glass. If some of the chairs were in the lay flat position or pulled out a few inches, Mr. Jaques opined that the walkway would violate industry standards, including but not limited to the ADA standards, which require “a clear width of not less than 36 inches[.]” D.E. 49 at 37.

The record further reflects that there are disputes of material fact regarding whether the chairs were in the upright or lay-flat position at the time of the accident, and whether the chairs were in line or out *1270 of position. For example, both Mrs. and Mr. Carroll testified in their depositions that at least some of the deck chairs were in the lay flat position. Mrs. Carroll also testified, however, that at the time of the accident the chairs “weren't messed up.” In contrast, Mr. Carroll testified that the chairs were not “orderly,” explaining that three or four of the chairs were “out of position” and “were pulled back from the glass several feet[.]” He explained that the chairs “were in the walkway,” which he

because, as discussed above, there is other evidence in the record establishing that there is a genuine dispute of material fact as to whether Carnival had notice of the dangerous condition.

described as being “more like an obstacle course,” and estimated that the width of the walkway was about 20 inches.

A reasonable jury could find that at least some chairs were in the lay-flat position and out of order, and thus conclude—in conjunction with Mr. Jaques’ testimony—that Carnival negligently maintained an unsafe walkway that fell below industry standards. The district court therefore erred in granting summary judgment on Mrs. Carroll’s negligent maintenance claim.

We reverse the district court’s grant of summary judgment in favor of Carnival and remand for further proceedings consistent with this opinion.

Note 1. While maritime law is applicable here, it adopts the general principles of tort law with which you are gaining familiarity.

Note 2. Given that this is a case concerning Carnival’s **duty** to Carroll, why does the court discuss the *conduct* of both parties, thus impliedly addressing **breach of duty**?

Note 3. The “open and obvious” defense pertains to premises liability as well as any claim arising from a failure to warn. How obvious does a risk factor or danger have to be for it to be deemed “open and obvious”? Do you think age, cognitive ability, education or language should matter to whether someone understands risks to be “obvious”?

In a footnote omitted from the opinion, the court clarifies its open-and-obvious standard:

We have repeatedly acknowledged and applied this reasonable person standard in unpublished maritime decisions. *See, e.g.,* [c] *Horne v. Carnival Corp.*, 741 F. App’x 607, 609 (11th Cir. 2018) (“A cruise line does not need to warn passengers or make special arrangements for open-and-obvious risks.... In determining whether a risk is open and obvious, we focus on ‘what an objectively reasonable person would observe and do[] not take into account the plaintiff’s subjective perceptions.’”) (internal quotation marks and citations omitted) [c].

However, duty is determined as a question of law and the “open and obvious” defense is often used to defeat a claim of duty. Are determinations of “open and obviousness” better suited to fact-based adjudication of the reasonable person’s understanding of the risk? Or should truly “open and obvious” hazards be dealt with as a matter of law, in keeping with the categorical, higher-level determinations of duty?

Note 4. How does the court deal with the plaintiff’s testimony relative to the reasons why she walked behind her husband? What significance might that have socioculturally and legally?

Duties Determined by Type of Harm

Pure Economic Losses (no duty) versus Pure Emotional Losses (duty in certain cases)

Purely Economic Losses. Despite the modern view that people have a **general duty to refrain from conduct that will foreseeably cause physical harm** to others, there is **no duty to refrain** from conduct that would cause **purely economic losses**. This is one way in which tort law has policed its

scope. By refusing recovery for losses that are purely economic, tort law forces parties to find alternatives in private ordering such as contracts and home, auto, or business interruption insurance. These alternatives are deemed better suited than tort law to protect against certain kinds of harms and risks. Consider whether these private ordering alternatives serve equally well all entities potentially harmed by tortious conduct.

Purely Emotional Losses. At common law, recovery in tort law was generally unavailable or extremely limited for losses that were purely emotional. This rule has been eroded over time, as is reflected by the introduction of torts that make severe emotional distress a cognizable injury under certain circumstances, namely, IIED, NIED (Negligent Infliction of Emotional Distress) or both. You have already learned about the challenges of prevailing with IIED claims, in Module 2. While in most jurisdictions, plaintiffs *can* recover for purely emotional losses under negligence, the challenges for plaintiffs are usually even greater than those posed by IIED claims.

Most courts are reluctant to allow recovery for NIED, for several reasons. First, emotional distress without any accompanying physical harm is usually ephemeral and may be difficult to measure or prove. Second, the scope of liability seems potentially limitless; if an accident causes a gruesome injury, the tortfeasor could potentially be liable to a large number of people who witnessed it if all bystanders were eligible to sue for the distress they suffered. Third, there is a concern that NIED claims may reflect attempts to use private insurance policies strategically. Most insurance policies have exclusions for intentional torts but include negligence claims. Thus, by characterizing conduct causing an emotional injury as negligent rather than intentional, a plaintiff could tap into significant resources that might not otherwise be available.

The rules that shape NIED vary greatly by state, yet they consistently create hurdles or outright bars for plaintiffs. Among the many different approaches employed by the states, four common categories can be identified: (1) states that follow some version of the “physical impact rule”; (2) states that require that plaintiffs have been in the “zone of danger”; (3) states that apply the “relative bystander” rule; (4) states that apply foreseeability analysis and limit recovery to when a defendant ought to have anticipated causing emotional distress to people like the plaintiff.

The **physical impact rule** bars recovery for claims of NIED based on witnessing negligent injury to another unless the plaintiff has suffered a physical impact or injury in the same incident. The impact itself could be minor but it suggests that the plaintiff was close and directly affected by the tortfeasor’s injury of the other person.

The **zone of danger rule** permits recovery only when the plaintiff was in the zone of physical danger created by the defendant’s tortious conduct, and this may be defined in terms of either proximity in space or time, closeness of familial connection, or both. Proximity may be used as a term of art, therefore, that means not just physically nearby, but also close in terms of relationships the law is especially intended to protect.

The **relative bystander rule** requires that the bystander whose claim depends on having witnessed the injury to another be related in some way, whether through marriage or other familial relation. It may also require proximity in space and or immediacy in time such that the claim depends on having been near to and aware of a loved one or family member’s suffering *while* that person experiences the physical injury caused by the defendant.

These limits—physical impact, proximity within the zone of danger, and foreseeability—significantly narrow the scope of the tort. They do so by using the element of duty as a gatekeeping mechanism.

Contreras v. Carbon County School District # 1 et al, Supreme Court of Wyoming (1992) (843 P.2d 589)

This case involves a claim for damages resulting from personal injury caused by a playground accident at Pershing Elementary School. Appellants James Contreras, Brenda Contreras and Odorico Contreras appeal the order granting judgment on a jury verdict for defendants-appellees, and denying their motion for a new trial. At issue is whether the trial court properly granted partial summary judgment on appellants' negligent infliction of emotional distress claim.[***]

We affirm. [***]

January 25, 1989, was a cold, blustery day in Rawlins, Wyoming. The weather that morning did not keep about 150 to 200 children from gathering, as they often did, outside Pershing Elementary School to play in the school playground before school began. The children were supervised by two school employees, appellees Belinda Wells and Kathleen Shamion. The playground at Pershing Elementary was divided into two segments. The west end, with swings and other playground equipment, was where the little children played together. The east, or "high activity" end, was where the older children played. This segregation of the playground was established mostly by convention and the tendency of children to play with those their own age. There was no physical barrier of any sort between the high-activity area and the area to the west of it where the younger children played, although the playground supervisors did try to keep the younger children out of the high-activity area.

In the high-activity area there was a football field marked out in white lines. On the morning in question, several fifth-grade boys were playing their daily game of football on the field. They had been instructed to keep within the white lines. One of the boys, Chuck Juare, was running backwards to catch a pass when he collided with appellant James Contreras. James was then seven years old and in the first grade. James was knocked off his feet, and Chuck fell on top of him. Another fifth-grade boy, Nick Armijo, was shadowing Chuck in the game. After Chuck fell, Nick tripped over Chuck and James and fell on top of them.

Mrs. Wells, Mrs. Shamion, and the school principal, Robert Johnson, soon arrived at the spot where James Contreras lie crying and in pain. James repeatedly told Johnson that his leg hurt. After ascertaining that the child had no back, neck or head injuries, Johnson decided to take him indoors because of the cold. He carried James about 200 feet, first into the school building and then into the school office. Johnson placed James on a nurse's cot in the office. Mr. Johnson's secretary called James' mother, appellant Brenda Contreras, to inform her that her son had been hurt. Mrs. Contreras drove quickly to the school. When she got out of her car in front of the school building, she could hear her son crying. She followed the sound of crying to the office, where she discovered her son lying on the cot in intense pain. His crying disturbed her so much that soon she too was crying. Mr. Johnson asked Mrs. Contreras whether she wanted an ambulance called. She said that she did.

When the paramedics arrived, they cut the leg off James' jeans to observe his injuries. They discovered that James had an inverted right femur, which is a very painful fracture of the longest bone in the human body. The femur in James' leg was *592 visibly twisted toward the other leg. Mrs. Contreras was told that her son's leg was broken. James was taken to the hospital in an ambulance, where he was fitted with a body cast which he wore subsequently for two and one-half months.

James, his mother and his father all filed suit against Carbon County School District No. 1, Mrs. Wells, Mrs. Shamion, Robert Johnson, Chuck Juare and Nick Armijo. In addition to claims for medical expenses, home health care provided, and compensation for James' pain and suffering, Brenda Contreras requested in the complaint damages for the emotional distress she incurred at seeing her son in severe pain and worrying that he might be permanently deformed by the injury. The trial court entered judgment against Mrs. Contreras on her emotional distress claim. Nick Armijo was never served with process, and the claim against Chuck Juare was dismissed after he reached a settlement with the plaintiffs. The remainder of the claims were allowed to go to the jury. After trial, the jury returned a verdict in favor of the defendants on all claims.

[***][A]ppellants challenge the trial court's finding that an emotional distress claim is precluded by our decision in *Gates v. Richardson*, 719 P.2d 193 (Wyo.1986).

[***] In *Gates v. Richardson*, 719 P.2d 193 (Wyo.1986), we recognized the tort of negligent infliction of emotional distress. In order to avoid burdening our court system with an overbroad theory of liability, we placed limits on possible recovery under that cause of action. We held that only those plaintiffs could recover: (1) whose kinship to the accident victim would permit them to bring a wrongful death action; (2) who observed the infliction of serious bodily harm or death, or observed the serious bodily harm or death shortly after its occurrence but without material change in the condition or location of the victim; and (3) whose loved one did, in fact, sustain death or "serious bodily injury" as defined in the Wyoming Criminal Code. *Gates*, 719 P.2d at 198–99. The trial court granted summary judgment here on appellants' failure to meet the second element of the *Gates* test, the immediacy of the observation.

Wyoming is one among a small number of states which allows recovery for the emotional distress a plaintiff experiences when she observes a loved one seriously injured or dead *after* the injury has actually occurred. [c] Our immediacy test allows some time to elapse between the time of injury and the time of observation. Once the victim's condition or location has materially changed, however, the moment of crisis for which recovery is allowed is deemed to have passed, regardless of the brevity of time which has elapsed since the accident. Shock or emotional distress may occur after this point, but it is no longer compensable.

If this rule seems harsh, we must point out that Wyoming follows a more liberal course than do many jurisdictions, including California, whose landmark case of *Dillon v. Legg*, 68 Cal.2d 728, (1968) so heavily influenced our adoption of the modern version of the tort. *Gates*, 719 P.2d at 195. While the California Supreme Court's position in *Dillon* was at the forefront of the law, that court, refining *Dillon*, recently rejected an emotional distress claim by a woman who arrived at an accident scene and found her bloody, unconscious son lying in the roadway, because she did not *actually witness* the accident. *Thing v. La Chusa*, 48 Cal.3d 644 (1989). This is a much harsher result than our rule requires. In fact, the dissent in *Thing* cited language from *Gates* as an example of the more liberal rule that California should have adopted. *Thing*, 257 Cal.Rptr. at 892–93 [***].

Our broader immediacy rule, which allows the plaintiff to recover if she observes the injury shortly after it occurs without material change in the attendant circumstances, was adopted from the Massachusetts case of *Dziokonski v. Babineau*, 375 Mass. 555 (1978). *Gates*, 719 P.2d at 199. Massachusetts expanded the *Dziokonski* rule early on to include emotional distress claims predicated on viewing the injured person at the hospital rather than at the scene. *Ferriter v. Daniel O'Connell's Sons, Inc.*, 381 Mass. 507 (1980). On this point, we must decline to follow the Massachusetts rule. The shock received on seeing an injured loved one in a hospital setting, or lying on a cot in a principal's office, is of a different quality than coming upon him or her at the scene of the accident. In our view, *Ferriter* over-emphasized the factor of whether chronological time had elapsed since the accident and under-emphasized the circumstantial factors under which the observation was made.⁹²

Turning to the circumstances of this case, Mrs. Contreras did not observe the infliction of her son's injuries. She did see him in pain shortly after the accident. However, he had been removed to the principal's office and was lying on a cot at the time. There had, therefore, been a "material change" in his location sufficient to mitigate the shock of the accident. While it is true that seeing her son's injuries must have been extremely distressing to Mrs. Contreras, a victim's loved ones are not entitled to recover for the emotions created by every shocking or upsetting injury to the victim, only to those which fall within the limitations of the cause of action as we have recognized it. *See Thing*, 257 Cal.Rptr. at 879–80. We therefore hold that Mrs. Contreras did not, as a matter of law, state a claim for negligent infliction of emotional distress because she did not observe the accident or observe the victim in substantially the same location and condition as when the accident occurred. [***]

Note 1. Descriptively, what facts would have needed to change in order for Mrs. Contreras to recover for the shock and upset of her son's injuries?

Note 2. Normatively, do you think the court draws the right line in denying recovery on these facts? Would it matter to your analysis if her son had died versus being injured?

Note 3. What consequences can you imagine to a rule in which the parents of children severely injured at their (public) schools can sue over their emotional distress pertaining to those injuries even when not present? Might some so-called "helicopter" parents begin attending recess? Would legislatures be forced to fund tort liability at schools (and might that lead to some legislatures' defunding schools to a certain extent)? Might schools be optimally incentivized to maintain safe playgrounds and supervise play times? Are schools likely to achieve a balance that makes children, parents, and legislators happy? Should this balance matter for tort law's purposes?

Note 4. Physical Impact Rule, A Deeper Dive. At common law, the general rule was that claims for emotional distress could not succeed unless they were accompanied by physical harms. Thus the first hurdle to the creation of a claim for NIED was the abrogation or modification of the "physical impact rule." In *Falzone v. Busch*, 45 N.J. 559, 561 (1965), Mabel Falzone, was in the car next to her husband, parked lawfully, when her husband was struck by the defendant's car veering negligently across the highway. She perceived it and it came "so close to plaintiff as to put her in fear for her safety." Although it had not struck her and thus her claim did not satisfy the physical impact rule, the court permitted

⁹² Moreover, we note that in recent years the Massachusetts courts have shown marked reluctance to further broaden the horizons of emotional distress claims. [Collecting cases]

recovery on the grounds that such impact had been possible. It was thus reasonable of Mrs. Falzone to fear the impact, which made her ensuing emotional distress credible. In *Portee v. Jaffee*, a mother never feared for her own physical harm or impact but suffered emotional distress when her child died tragically and slowly before her eyes. The trial court, following *Falzone*, ruled against the plaintiff since she had faced neither physical harm nor probable or imminent contact. The Supreme Court reversed:

Plaintiff's seven-year-old son, Guy Portee, resided with his mother in a Newark apartment building. Defendants Edith Jaffee and Nathan Jaffee owned and operated the building. On the afternoon of May 22, 1976, the youngster became trapped in the building's elevator between its outer door and the wall of the elevator shaft. The elevator was activated and the boy was dragged up to the third floor. [fn] Another child who was racing up a nearby stairway to beat the elevator opened it, saw the victim wedged within it, and ran to seek help. Soon afterwards, plaintiff and officers of the Newark Police Department arrived. The officers worked for four and one-half hours to free the child. While their efforts continued, the plaintiff watched as her son moaned, cried out and flailed his arms. Much of the time she was restrained from touching him, apparently to prevent interference with the attempted rescue. The child suffered multiple bone fractures and massive internal hemorrhaging. He died while still trapped, his mother a helpless observer. *Portee v. Jaffee*, 84 N.J. 88, 91 (1980)

As the court notes in *Contreras*, California and Massachusetts followed slightly different trajectories, but all courts facing such claims have sought to find a balance between permitting some without opening the floodgates to "trivial" claims. Are the factors you see in the analysis thus far persuasive?

Note 5. Critiques of NIED's Various Tests. Many have criticized elements of the various tests for NIED. For instance, they maintain that the relative bystander rule provides no relief for bystanders who witness the suffering of non-familial loved ones even though it is often far more distressing to lose (or witness injury to) a beloved friend than it might be to experience the same with respect to an estranged family member or long-lost distant cousin. Nonetheless, courts that apply the test have tended to do so in a rigid, formalistic way.

Should courts adopt a rule that reflects the growing awareness of the social importance of friendships in society? See e.g. <https://www.theatlantic.com/family/archive/2020/10/people-who-prioritize-friendship-over-romance/616779/>

Other critics lament the rather technical (and sometimes trivializing) nature of the "proximity" and "immediacy" requirements applied as part of the zone of danger test (and sometimes also under the relative bystander test, which may require "contemporaneous presence"). For instance, if a person were present but sleeping through an injury, or looking away from the scene at the precise moment of injury, some courts would deny recovery (depending on the precise nature of the claim).

How much should legal technicalities matter in delineating the scope of liability for the negligent infliction of losses that are purely emotional? Do the tests' traditional limits reflect outdated notions of what it means "to be present"? How should they be applied in our increasingly "virtual" era? Would it satisfy the proximity requirement, for instance, to be on the phone with a family member who was dying in an accident negligently caused by the defendant? (Courts have come out differently on this question.) Would being on FaceTime or Zoom satisfy the proximity or contemporaneous presence

requirements? How about if the plaintiff witnessed harm to their loved one via livestream from a “nanny cam” (a device of some sort that audiovisually records activity in a child’s room or elsewhere in a home, designed to surveil childcare providers) in the plaintiff’s home? Recently, an appellate case in California answered in the affirmative.

Initially, the trial court ruled that the Ko family could *not* state a cause of action for NIED after witnessing their in-home caregiver, Thelma Manalastas, abusing their disabled son while the parents were out of the home. They observed the abuse from their smartphone, which captured video and audio on their nanny cam. The Kos brought suit against Manalastas for battery, assault, and negligence for their son (who died during the pendency of the litigation) and on their own behalf for NIED, suing Manalastas’ employer, Maxim Healthcare. Since the parents weren’t home during their child’s abuse, the trial court held that they failed to satisfy California’s requirement that a bystander be both present at the scene of the injury-producing event and aware that it is causing injury.

On appeal, the Kos argued that their “virtual presence” during their son’s abuse should satisfy the contemporaneous presence element required in California and the court agreed, reversing the trial court’s decision. *Ko v. Maxim Healthcare Servs., Inc.*, 58 Cal. App. 5th 1144, 1146–47, (2020), as modified (Jan. 14, 2021), *review denied* (Apr. 21, 2021). The Supreme Court’s reasoning was grounded in an awareness of technological change: “In the three decades since the Supreme Court [of California] decided *Thing* [*v. La Chusa* (1989) 48 Cal.3d 644, 668, the controlling precedent], technology for virtual presence has developed dramatically, such that it is now common for families to experience events as they unfold through the livestreaming of video and audio.” *Id.* at 1147. The court rejected the defendant’s attempts to downplay the significance of these social and technological changes in a thoughtful opinion that is worth quoting at length:

Maxim argues that “remote surveillance is nothing new, nor is watching events happening live with video and audio,” and contends that “[i]ncreased convenience does not mean we are any more able to be present in places where our bodies are not than we were in 1989.” Maxim and Manalastas contend that technology allowed live broadcasts decades ago, pointing to the live broadcast of the fatal shooting of Lee Harvey Oswald in 1963, the 1986 televised explosion of the space shuttle Challenger, and the use of closed-circuit television in courtrooms prior to *Thing*. But the Supreme Court in 1989 could not have reasonably anticipated the technological advances that now allow parents (and other family members) to have a contemporaneous sensory awareness of an event causing an injury to their child while not in physical proximity to the child.

Certainly, live television and remote video surveillance existed in 1989, but numerous technological, regulatory, and commercial developments in image capture (such as an Internet-enabled nanny cam), transmission (including the streaming of audiovisual data over the Internet and mobile data networks), and reception (such as on pocket-sized smartphones with high resolution screens) were necessary to create a world where parents could contemporaneously observe their at-home child while attending a basketball game. Indeed, the ubiquity of home surveillance systems and videoconferencing applications since the advent of Internet-enabled smartphones has manifestly changed the manner in which families spend time together and monitor their children. (*See e.g., Riley v. California* (2014) 573 U.S. 373, 385 [“These cases require

us to decide how the search incident to arrest doctrine applies to modern cell phones, which are now such a pervasive and insistent part of daily life that the proverbial visitor from Mars might conclude they were an important feature of human anatomy. A smart phone of the sort taken from [the defendant] was unheard of ten years ago; a significant majority of American adults now own such phones. [c] [Such] phones are based on technology nearly inconceivable just a few decades ago”.)

In various areas of the law affecting traditional conceptions of physical presence, the courts have been called upon to interpret longstanding precedent in light of new technologies. [***] Where plaintiffs allege they were virtually present at the scene of an injury-producing event sufficient for them to have a contemporaneous sensory awareness of the event causing injury to their loved one, they satisfy the second *Thing* requirement to state a cause of action for NIED. Just as the Supreme Court has ruled a “plaintiff may recover based on an event perceived by other senses so long as the event is contemporaneously understood as causing injury to a close relative” [c] so too can the Kos pursue an NIED claim where, as alleged, they contemporaneously saw and heard Landon’s abuse, but with their senses technologically extended beyond the walls of their home.

Here, as alleged, the Kos were virtually present through modern technology that streamed the audio and video on which they watched Manalastas assaulting Landon in real time, and thus “personally and contemporaneously perceive[d] the injury-producing event and its traumatic consequences.” (*Thing, supra*, 48 Cal.3d at p. 666.) Based on these allegations, the Kos have stated facts sufficient to constitute a cause of action for NIED. (*Thing, supra*, 48 Cal.3d at pp. 666, 668.)

The judgment is reversed. The matter is remanded with directions to the trial court [***]. The Kos are to recover their costs on appeal. *Id.* at 1157–60.

Based on what you have learned about NIED so far, what do you think of this reasoning, descriptively and normatively?

Note 6. Culpability. Negligent infliction of emotional distress differs from IIED in having a much lower conduct standard: it requires only carelessness, not intentional or reckless conduct. Notwithstanding case law to the contrary, extreme and outrageous conduct is not an essential element of a cause of action to recover damages for negligent infliction of emotional distress. *Taggart v. Costabile*, 131 A.D.3d 243, 255 (Sup. Ct. App. Div. 2d Dept., NY, 2015).

Summary of Types of Duty:

- **General Duty:** the modern rule, applicable in *most* cases: *everyone has a duty* to refrain from conduct that will cause foreseeable harm
- **Duty as a Function of Foreseeability:** a duty arises when there is harm to a foreseeable person or a foreseeable harm that can be created or increased through one’s actions (*Walls v. Oxford Management* and *Tarasoff, Palsgraf* though there the court found *no* duty)

- **No Duty:** *there is no* duty to “rescue” or take action to help others relative to harms one didn’t create or risks one didn’t increase (*Harper v. Herman; Sidwell v. McVay*)
- **Duty Based on Relationship or Undertaking:** *a duty arises* when there is a *special relationship between parties* (the special relationship may be contractual, familial or social (recall wingman liability as in *Farwell v. Keaton*); or the special nature of the therapist’s work as in *Tarasoff*); or *when a party volunteers* (a “gratuitous undertaking”) and *thus creates* a duty
- **Duties of Common Carriers or Innkeepers:** special duties attach to the activities of common carrier and innkeepers because of the control and power they exercise over the passengers or customers temporarily in their custody (*Bullock, Maison*)
- **Duty Related to Premises Liability:** owners and possessors of land usually owe a duty of care towards entrants on their land but what that requires of them depends on the jurisdiction (*Carroll v. Carnival*); the majority of jurisdictions refer to the status of the entrant to specify the level of care required whereas the minority approach applies “reasonableness” (*Rowland v. Christian*)
- **Duty Determined by Type of Harm:** in limited cases *involving purely emotional harms*, courts will determine whether a duty exists based on a restrictive set of factors varying by jurisdiction (*Contreras v. Carbon County*); there is no duty to compensate *for purely economic losses* caused by one’s conduct

Check Your Understanding (3-3)

Question 1. True or false: While there is no duty to rescue people from harm initially caused by others, all people have a general duty to refrain from conduct that increases the risks of harm flowing from negligent conduct by others.

An interactive H5P element has been excluded from this version of the text. You can view it online here: <https://saidtorts2d.lawbooks.cali.org/?p=55#h5p-63>

Question 2. True or false: Based on what you have learned in Torts so far, *Harper v. Herman* would come out the same way if decided in 2021. Assume no changes of facts (so, no contractual waiver of liability involved) and no relevant ordinances at issue (such as regulations pertaining to boating).

An interactive H5P element has been excluded from this version of the text. You can view it online here: <https://saidtorts2d.lawbooks.cali.org/?p=55#h5p-64>

Question 3. Which of the following scenarios, below, is *least* likely to fall within one of the exceptions to the no duty rule that the Restatement Section 314A identifies? Put another way, which of these scenarios is likeliest to find a duty exists? You may wish to review the language of 314A.

An interactive H5P element has been excluded from this version of the text. You can view it online here: <https://saidtorts2d.lawbooks.cali.org/?p=55#h5p-65>

This was a challenging question since it asks you to read three mini fact patterns as well as the Restatement factors and then apply those factors to the fact patterns. The structure of the inquiry is also challenging: if the factors applied, then duty *would* exist, meaning the “no duty default rule” would be negated. There’s some challenge just in conceptualizing an exception to a default rule, all on its own. There is an additional challenge in the fact that premises liability cases often formulate liability in terms of whether a duty exists when in fact the true legal question is whether the defendant had *a duty to do a particular thing on these facts* which sounds a great deal like breach analysis. Recall that the limited duty cases often do present hybrid analysis of just this kind and may ultimately present a jury question, just as *Farwell v. Keaton*, above, demonstrated.

Question 4. Patel runs a tourism business that, among other things, gives tours of Lake Union and Lake Washington to introduce visitors to the area. It shows them landmarks such as Gasworks Park, the University of Washington, various bridges and significant buildings, as well as houseboats, which are always a source of curiosity and interest for out of towners. The way to see houseboats, in particular is to get up close, on a small vessel (or even kayaks and paddleboards). A large shipping company, the Ballard Asset Development Company (“Bad Co”), is responsible for dumping a huge volume of chemicals into the water, and as a result, both bodies of water are deemed hazard sites and off limits. Patel grows extremely sad upon hearing the news. First, he is an environmentalist, and cares deeply about the air, water, and land. Second, he is aware that this will have a significant impact on his business. Some businesses are allowed to continue to navigate the water in limited ways if they have previously applied for a special business license that is required for those who run businesses making use of the waterways. Patel intended to file for one, but never got around to it. He knew it was technically a statutory violation but he thought of it as a “victimless crime” and intended to rectify the problem at some point. Even those businesses that can access the bodies of water, however, are restricted to twice daily passage, which limits his ability to conduct his business. He loses significant revenues as a result and as the process of cleaning up the sites drags on for weeks, and then months, he is forced to take increasing measures to protect himself financially. Finally, he applies for bankruptcy. He would also like to sue Bad Co for their conduct.

Which principle(s), of those stated below, will cause Patel’s claim to fail under tort law?

- (i) Bad Actor will not be liable to Patel for his emotional losses under IIED because Patel cannot make out the required elements
- (ii) Bad Actor owes no duty to Patel for his economic losses
- (iii) Bad Actor owes no duty to Patel under *Tarasoff* because he was not a specific third party

An interactive H5P element has been excluded from this version of the text. You can view it online here: <https://saidtorts2d.lawbooks.cali.org/?p=55#h5p-66>

Chapter 16. Negligence: Breach

The Standard of Care

The standard for whether an actor was negligent is reasonableness: was the conduct in question reasonable under the circumstances? The law asks what a reasonable person would do under the circumstances, as a question of fact that varies based on the facts of a given case. The reasonable person standard is set out as an objective standard, asking what the hypothetical “reasonable person” would have done or should have known under the circumstances. This objective standard stands in contrast with a subjective standard which would ask what *this defendant* actually thought, knew or intended on these circumstances.

Generally, look for a precaution that could have been taken and that wasn't. If it wasn't, perhaps that was reasonable because the precaution was too costly or prohibitive; perhaps it would have required eliminating socially valuable conduct in order to eliminate the risks. Introducing that high a level of precaution to prevent risks deemed merely *possible*, not likely or probable, is suboptimal and not the standard tort law seeks to achieve.

A representative formulation of negligence provides an instructive point of departure for understanding what constitutes breach of the duty of care.

Wisconsin Jury Instruction 1005 Negligence: Defined, states “A person is negligent when he fails to exercise ordinary care. Ordinary care is the care which a reasonable person would use in similar circumstances. A person is not using ordinary care and is negligent if the person, without intending to do harm, does something or fails to do something that a reasonable person would recognize as creating an unreasonable risk of injury or damage to a person or property.”

In particular, using a jury instruction allows students to see how courts and juries are intended to arrive at a determination of negligence. However, this general formulation raises many questions.

Questions or Areas of Focus for the Readings

- What sorts of circumstances is the reasonable person expected to protect against?
- Who is the reasonable person by which we measure all of this potential tort liability?
- What does the reasonable person standard look like at different points in time, in different places, and for people of differing age, experience and ability?
- What kinds of conditions foreseeably lead to preventable injuries or, conversely, excuse lapses in conduct, making them unreasonable, versus reasonable?
- What kinds of evidence will be necessary to prove up the answers to these various questions?
- What happens when evidence is unavailable or missing?

The next few cases deal with how to define the standard of care and identify its breach; how to apply the reasonable person standard; and how to approach challenges in proving breach.

Blyth v. Birmingham Waterworks Co., Court of Exchequer (1856) (11 Exch. 781, 156 Eng. Rep. 1047)

Defendants had installed water mains in the street, with fire plugs at various points. The plug opposite the plaintiff's house sprung a leak during a severe frost, because the connection between the plug and the water main was forced out by the expansion of freezing water. As a result, a large quantity of water escaped through the earth and into plaintiff's house, causing damage. The apparatus had been laid down 25 years ago, and had worked well during that time. The trial court left the question of defendant's negligence to the jury, which returned a verdict for plaintiff. Judgment was entered on the verdict, and defendant appealed.

ALDERSON, B. I am of opinion that there was no evidence to be left to the jury. The case turns upon the question, whether the facts proved show that the defendants were guilty of negligence. Negligence is the omission to do something which a reasonable man, guided upon those considerations which ordinarily regulate the conduct of human affairs, would do or doing something which a prudent and reasonable man would not do. The defendants might have been liable for negligence, if unintentionally, they omitted to do that which a reasonable person would have done, or did that which a person taking reasonable precautions would not have done. A reasonable man would act with reference to the average circumstances of the temperature in ordinary years. The defendants had provided against such frosts as experience would have led men, acting prudently, to provide against; and they are not guilty of negligence, because their precautions proved insufficient against the effects of the extreme severity of the frost of 1855, which penetrated to a greater depth than any which ordinarily occurs south of the polar regions. Such a state of circumstances constitutes a contingency against which no reasonable man can provide. The result was an accident for which the defendants cannot be held liable. Verdict to be entered for the defendants.

Note 1. How do you formulate the rule in this case? If you're struggling to zero in on it, cast your mind back your to introduction to negligence. Can you use the *rationale behind the* negligence calculus—tort law does not require that risks be completely eliminated, only optimized in light of necessary precautions and likely risk—to shape a rule here?

Note 2. How far should this rule extend? If someone moves to the Pacific Northwest and fails to take precautions against rainy weather conditions, their very first days might excuse a lack of awareness of their environs. However, at some point it ceases to be reasonable *not* to learn how to navigate one's daily terrain and climate. Similarly, if someone moves to a mountain town and fails to learn how to drive in the ice and snow, it's clearly unreasonable after some period of time. Does it matter what time of year they move? Should it be the same amount of time if they arrive in July versus January? What sort of rule would capture that reasoning? How far should it extend? Should the same rules apply to tourists visiting from other cultures and climates? Is it unfair *not* to tailor the reasonable person standard under certain circumstances? In whose view would it be unfair? Is it inefficient if we *do* tailor the reasonable person standard, that is, make it subjective to the particular defendant?

Note 3. *Blyth* was reportedly the first case in which the “reasonable person” framing appeared. What do you suspect accounts for the shift in the later cases to the term “reasonable man” instead of reasonable person?

Expand On Your Understanding – Storm Hypothetical

Blyth's reasoning proceeds as though it were always evident what sorts of precautions might be reasonable or necessary and thus implicitly also assumes that it may be clear whether a weather event is an extreme contingency. But is an extreme weather event, like a typhoon, always identifiable as such before or during the event? At what point does extreme weather become an "act of God" or "force majeure" that may change the legal status of rights and duties owed to parties affected by it? How should the law distinguish between very bad weather, the kind against which parties can be expected to take reasonable precautions, and freakish or extreme and unusual circumstances against which precautions would cease to be reasonable? How much does context play a role?

In *Nissan Motor Corp. in Guam v. Sea Star Grp. Inc.*, 2002 Guam 5, (Guam Apr. 9, 2002), [car manufacturer] Nissan sought recovery for fourteen vehicles that were damaged during Typhoon Paka [in Guam]. The vehicles were among several hundred new vehicles stored by Nissan on a lot adjacent to property owned by Sea Star. Sea Star maintained a twenty-seven-foot aluminum storage container on its property that was used as a satellite office. In preparing for the arrival of the typhoon, Sea Star attempted to secure the container by moving it up against a cyclone fence and pinning it to the ground by bending four rebar stakes around the container's edges. During Typhoon Paka's passage, the container was picked up and carried approximately 130 feet. It eventually landed on the fence separating Nissan and Sea Star's lots, coming to rest against the rear of five Nissan vehicles. Nissan also alleges that nine other vehicles suffered damage from the container's flying debris. Nissan filed suit against Sea Star arguing that Sea Star negligently failed to secure its property and that this negligence resulted in the damage to Nissan's property. *Id.* at 12

Under *Blyth*, what result? Recall its core reasoning: "A reasonable man would act with reference to the average circumstances of the temperature in ordinary years" and its reference to a "state of circumstances [that] constitutes a contingency against which no reasonable man can provide."

An interactive H5P element has been excluded from this version of the text. You can view it online here: <https://saidtorts2d.lawbooks.cali.org/?p=57#h5p-67>

Note 4. The Negligence Calculus. While there is no magic equation or formula that can yield a conclusion of negligence, there is a predictable policy balancing that must take place. The **negligence calculus** (sometimes referred to as the “**Hand formula**”), asks whether the burdens of precaution in a given situation outweigh the likelihood of risks occurring that will cause serious harm. In *U.S. v. Carroll Towing*, 159 F.2d 169 (2d Cir. 1947), Judge Learned Hand considered extensive losses that had occurred when a negligently secured barge and an absent bargee’s conduct caused damage to several other barges and their cargo, including causing a barge to sink. The harbor was busy and crowded with World War II barge traffic, and Judge Hand’s analysis sought to contextualize the fact that the bargee had left his barge unattended in light of the risks attendant on that action during that particular time and place.

[T]here is no general rule to determine when the absence of a bargee or other attendant will make the owner of the barge liable for injuries to other vessels if she breaks away from her moorings. [***] It becomes apparent why there can be no such general rule, when we consider the grounds for such a liability. Since there are occasions when every vessel will break from her moorings, and since, if she does, she becomes a menace to those about her; the owner’s duty, as in other similar situations, to provide against resulting injuries is a function of three variables:

- (1) The probability that she will break away;
- (2) the gravity of the resulting injury, if she does;
- (3) the burden of adequate precautions.

Possibly it serves to bring this notion into relief to state it in algebraic terms: if the probability be called P; the injury, L; and the burden, B; liability depends upon whether B is less than L multiplied by P: i.e., whether $B < PL$.

Applied to the situation at bar, the likelihood that a barge will break from her fasts and the damage she will do, vary with the place and time; for example, if a storm threatens, the danger is greater; so it is, if she is in a crowded harbor where moored barges are constantly being shifted about. On the other hand, the barge must not be the bargee’s prison, even though he lives aboard; he must go ashore at times. We need not say whether, even in such crowded waters as New York Harbor a bargee must be aboard at night at all; it may be that the custom is otherwise, [***] and that, if so, the situation is one where custom should control. We leave that question open; but we hold that it is not in all cases a sufficient answer to a bargee’s absence without excuse, during working hours, that he has properly made fast his barge to a pier, when he leaves her. In the case at bar the bargee left at five o’clock in the afternoon of January 3rd, and the flotilla broke away at about two o’clock in the afternoon of the following day, twenty-one hours afterwards. The bargee had been away all the time, and we hold that his fabricated story was affirmative evidence that he had no excuse for his absence. At the locus in quo—especially during the short January days and in the full tide of war activity—barges were being constantly ‘drilled’ in and out. Certainly it was not beyond reasonable expectation that, with the inevitable haste and bustle, the work might not be done with adequate care. In such circumstances we hold—and it is all that we do hold—that it was a fair requirement that the Connors Company should have a bargee aboard

(unless he had some excuse for his absence), during the working hours of daylight. *United States v. Carroll Towing Co.*, 159 F.2d 169, 173–74 (2d Cir. 1947).

Judge Hand’s opinion exemplifies the fact-sensitive balancing of negligence determinations. He highlights the importance of a bargee’s remaining present, especially if a barge is “in a crowded harbor” and “a storm threatens.” However, the costs of a bargee’s presence should not be so great as to make “the barge... the bargee’s prison.” He acknowledges there may be excuses for a bargee’s absence and dismisses that possibility here given the 21-hour absence of this bargee on facts that were uncertain, possibly a “fabricated story” that may have been covering up for the bargee’s going on an unauthorized bender ashore. In his attentiveness to the factual specificity of the context, Judge Hand demonstrates particularization that is characteristic of the common law of torts. Again, Judge Hand’s formula, “**B < PL**” is not an equation that will always produce a finding of negligence merely because the **Burdens** of precaution are lower than the **Probability** of harm multiplied by the severity of the **Loss**. However, it provides insight into how many courts approach the questions of negligence or instruct juries to do so. It may be difficult to overcome the intuitions that arise upon a showing that the burdens of precaution were low but not taken, even when risks threatened and those risks portended significant possible harm. Inversely, if the precautions were very costly—such as asking epileptic drivers to cease driving altogether as in Module 1’s *Hammontree v. Jenner*—even when the risks were low—such as when the epileptic drivers faced very low risks of seizure, it would be harder to argue persuasively in favor of finding negligence if harm does result. In some sense, the negligence calculus reflects little more than common sense balancing of risks with predictions of their possible impact.

Brake repair hypothetical 1. Imagine that you learn that a vehicle you own requires brake repairs. These repairs are not costly, and your mechanic informs you that they should be undertaken immediately because the risk that the brakes will not function is high. Since you own a vehicle, it is safe to assume you are aware of the importance of braking and the significant safety risks attendant on being unable to brake properly. Under the negligence calculus, the burdens are not very high (your mechanic’s quote is “not costly”) but the probability of harm is high. While we can’t know precisely how severe the loss will be (will you drive the car at high speeds? On dangerous, hilly, or slick terrain?), the calculus would generally tend towards a conclusion of negligence if the driver, once warned, failed to get the brakes repaired. This assessment likely mirrors your intuitions as you consider the options before you.

Brake repair hypothetical 2. Now imagine that the brake repairs are very costly. Given the significance of the harm associated with failures to brake, this might not change much in the negligence calculus. If the risk of harm is high, it might be unreasonable to drive a car simply because you can’t afford the repairs to it right away. The law reasonably expects you to refrain from engaging in conduct with a high level of risking harm to others.

Brake repair hypothetical 3. Consider the same facts as in #2, except that you use the car to transport someone a short distance to the hospital during a situation in which they face a sudden and unexpected health emergency whose complications cannot await even the time needed to call an ambulance. Is your assessment shifting as the risk of harm by possible brake failure changes with additional, possibly countervailing harms and pressures entering the picture? Or do alternatives (a friend’s car? A ride share or taxi?) seem plausible and preferable to taking the risks associated with driving a potentially unsafe car?

Brake repair hypothetical 4. Imagine that the mechanic has stated that the repairs are moderately costly, neither cheap nor exorbitant. However, the likelihood that they will malfunction is small. It is possible but not probable, that the brakes will fail before your next oil change in a few months. Now you may have different intuitions depending on how the costs of the repairs match your socioeconomic capacity, the regularity with which you need your car and your uses for it, your tolerance for risk, and the counsel of your mechanic overall.

Negligence law is filled with small factual details that involve awareness and assessment of risk as well as balancing a constellation of considerations. You don't need a car to follow the hypotheticals above; most of us engage in this kind of risk prediction and management all the time in our daily lives, if on a smaller scale. Indeed, this is probably the main reason why the jury's everyday experience is thought to be the proper sort of expertise for determining negligence. Many doctrines have arisen that purport to guide these intuitions and label them so that courts can imbue them with authority for subsequent courts to recognize and follow or distinguish. How useful is it to categorize and label this kind of thinking? To what extent might human intuitions be shared or divergent as applied to various factual scenarios or as manifested in the case law of particular jurisdictions? Consider the example in the next case, centering on the "sudden emergency doctrine."

Lifson v. City of Syracuse, Court of Appeals of New York (2011) (17 N.Y.3d 492)

*495 Defendant Klink was the driver of an automobile that struck plaintiff's decedent, Irene Lifson, while she was crossing the street, causing her death. Pursuant to Klink's claim that the accident occurred while he was temporarily blinded by sun glare, the trial court instructed the jury on the emergency doctrine in his favor. We find that, under these circumstances, it was error to give the jury the emergency instruction.

Both Lifson and Klink worked in the MONY Plaza, a large office complex in Syracuse containing two 20-story high-rise office towers. MONY Plaza is located across the street from the Harrison Street Garage, where many of the employees park their cars during the work day. There is, as a result, a substantial amount of pedestrian traffic crossing Harrison Street between the towers and the garage, particularly during rush hours. Pedestrians would commonly cross Harrison Street where the MONY Towers' exit lines up with the entrance to the garage, despite the absence of a marked crosswalk at that location.

On February 29, 2000, the day of the accident, Klink retrieved his car after work. At approximately 4:05 p.m., he was attempting to make a left-hand turn onto Harrison Street from Harrison Place. Harrison Street is a three-lane, one-way road, with traffic running from east to west. Klink had been proceeding north on Harrison Place, which forms a "T" intersection with Harrison Street and was waiting to turn to the west. Although Klink worked at the MONY Towers, he testified that he was not familiar with driving this particular route because he parked in different locations throughout the city, rather than in the same place every day.

Klink testified that he stopped at the stop sign to make the left turn onto Harrison Street, but that his view of oncoming traffic was partially obstructed by parked cars in the left-hand lane of Harrison Street

and he had to “creep up” in order to see the approaching vehicles. He had noticed that there were pedestrians crossing Harrison Street to his left, but he also *496 asserted that he had looked in that direction and “cleared the road” before making the turn. He further testified that he had been looking to his right, toward the oncoming traffic when he started turning. He maintained that, when he looked back to his left, mid-turn, he was blinded by the sun, “all of a sudden.” His reaction was to look down and to his right and, when he looked up, the first object he saw was Ms. Lifson. Although he applied the brakes, he was unable to avoid hitting her, having seen her only a fraction of a second prior to impact. At the time of the accident, Ms. Lifson had been wearing a red coat. There was no evidence that Ms. Lifson darted out in front of Klink’s car, or that Klink was traveling at an excessive rate of speed.

Plaintiff commenced this action against Klink and the City of Syracuse [fn] alleging causes of action in negligence and failure to study/ plan for pedestrian traffic. [fn] The ensuing trial was limited to the issue of liability. As noted, pursuant to Klink’s request and over plaintiff’s objection, the trial court gave the jury an emergency doctrine instruction in Klink’s favor. The instruction generally conveyed to the jury that it had to determine whether Klink was in fact confronted with an emergency situation not of his own making and, if so, whether his conduct in response to that situation was that of a reasonably prudent person. The jury was free to reject both of those propositions, but if it determined that he had faced an emergency situation and acted reasonably, it was to find for Klink.

The jury returned a verdict attributing negligence to the City of Syracuse and Ms. Lifson [***]. Klink was found not negligent and the action was dismissed as against him. The Appellate Division affirmed, finding that the emergency instruction was properly given, as there was a reasonable view of the evidence showing that the sun glare was a sudden and unforeseen occurrence (72 A.D.3d 1523[2010]). One Justice dissented and would have found that Klink was not entitled to an emergency instruction because the sun glare should have been anticipated and was not unexpected in light of the circumstances surrounding the accident, including the sunny weather and the time of day. We granted plaintiff leave to appeal and now reverse.

***497** The common-law emergency doctrine

“recognizes that when an actor is faced with a sudden and unexpected circumstance which leaves little or no time for thought, deliberation or consideration, or causes the actor to be reasonably so disturbed that the actor must make a speedy decision without weighing alternative courses of conduct, the actor may not be negligent if the actions taken are reasonable and prudent in the emergency context, provided the actor has not created the emergency” (*Caristo v. Sanzone*, 96 N.Y.2d 172, [2001] [internal quotation marks and citation omitted]).

The doctrine recognizes that a person confronted with such an emergency situation “cannot reasonably be held to the same accuracy of judgment or conduct as one who has had full opportunity to reflect, even though it later appears that the actor made the wrong decision” [c]. [***]

In *Caristo*, the trial court gave an emergency instruction in favor of the defendant, who had been driving in icy conditions when his car slid down a hill, past a stop sign and hit the plaintiff’s vehicle. We reversed and ordered a new trial, finding no view of the evidence to support the conclusion that defendant faced a qualifying emergency. Specifically, since defendant had been aware of the poor and

deteriorating weather conditions that had existed for at least two hours, the resulting icy *498 conditions on the road could not be considered “sudden and unexpected.” [c]

By contrast, in *Ferrer v. Harris*, 55 N.Y.2d 285 (1982) we found that the defendant driver, whose vehicle struck a child who ran out into the street, was entitled to an emergency doctrine charge. The defendant had testified that he was driving well below the posted speed limit and that he stopped abruptly when he saw the child step off the sidewalk and run into the street between the parked cars. We determined that “it [was] more than conceivable that a jury could conclude that this defendant was faced with an emergency” [c].

The situation presented in this case bears closer resemblance to that in *Caristo*. While Klink did not drive this particular route often, he was familiar with the general area since he worked in the MONY Towers. Klink was about to turn to the west at a time of day that the sun would be setting. It is well known, and therefore cannot be considered a sudden and unexpected circumstance, that the sun can interfere with one’s vision as it nears the horizon at sunset, particularly when one is heading west. This is not to say that sun glare can never generate an emergency situation but, under the circumstances presented, there is no reasonable view of the evidence under which sun glare constitutes a qualifying emergency. Moreover, the error in giving the emergency instruction was not harmless. The improper charge permitted the jury to consider Klink’s action under an extremely favorable standard. Because the application of that instruction to the facts presented could have affected the outcome of the trial, it was not harmless error [c].

Plaintiff’s remaining contentions are without merit. Accordingly, the order of the Appellate Division, insofar as appealed from, should be reversed, with costs, the amended complaint reinstated as against defendant Derek Klink, and the case remitted to Supreme Court for further proceedings consistent with this opinion.

SMITH, J. (dissenting).

Plaintiff’s argument here rests on the seemingly obvious proposition that no one should be surprised to find the sun setting in the west. I admit that sunset is a foreseeable event. Yet surely everyone who has driven a car knows that good drivers are sometimes surprised to find the sun in their eyes. Drivers cannot be expected to have always at the *499 forefront of their minds the time of day, the season of the year, the direction they are traveling, the weather conditions and the presence or absence of obstruction in a particular spot. Therefore, sun glare, as the majority appears to acknowledge, can sometimes present an emergency situation.

In deciding whether an emergency instruction was properly given, the issue is not whether the emergency was foreseeable; it is whether it was sudden and unexpected. Our cases illustrate the distinction. In *Ferrer v. Harris*, the defendant driver was passing a park where he knew that children played, and it was obviously foreseeable that a child would step in front of his car; but the event was sudden and unexpected when it happened, and the driver was therefore entitled to an emergency instruction. In *Amaro v. City of New York*, 40 N.Y.2d 30 (1976), plaintiff was a firefighter who was injured in a fire-house while responding to a fire alarm; we held that the alarm, foreseeable as it was for that plaintiff in that location, was sudden and unexpected and that the plaintiff was properly accorded the benefit of an emergency charge. In *Kuci v. Manhattan & Bronx Surface Tr. Operating Auth.*, 88 N.Y.2d 923 (1996), the defendant’s employee, a bus driver, was familiar with the intersection where the accident occurred and knew “that cars frequently turned right from the left lane in front of

buses in this area.” We nevertheless held that it was error to deny an emergency charge, because the driver’s general awareness that such turns often happen “would not preclude a jury from deciding that, as to the events in issue in this case, the driver did not anticipate being suddenly cut off by this particular car” (*id.*).

Caristo v. Sanzone appears to be the only case in which we have held an emergency instruction was improperly given. There, the defendant was driving in bad weather—a mixture of snow, frozen rain and hail. The claimed emergency was that he encountered a sheet of ice. We held, five to two, that in view of the driver’s knowledge of the weather conditions “the presence of ice on the hill cannot be deemed a sudden and unexpected emergency” (*id.* at 175). *Caristo* thus holds that no one driving through such conditions, while exercising reasonable care, could be surprised to find that the road was icy.

A similar holding is not justified here. The record, read most favorably to Klink, shows that he was driving on a city street, where buildings sometimes do and sometimes do not block the *500 sun, and that he was unfamiliar with the route. A jury could surely find that he did not calculate the direction of his travel, the time of day and the time of year so precisely that he expected to find the sun in his eyes when he turned. The emergency instruction was properly given.

Note 1. Do you think the emergency instruction *should* have been given (as do dissent and the majority opinion in the court below) or do you agree with the majority about its impropriety on these facts? Why?

Note 2. Descriptively, cases like *Lifson* are decided on facts as a determination of the breach of duty. This is why the opinions spend so much time analogizing and distinguishing precedents and framing the facts of various accidents. Normatively, do you think it would be better or worse for certain recurring situations (like sun glare or ice storms) to be determined as a function of duty, that is as a question of law for the judge? What would be gained or lost in such a situation?

Note 3. How much should context matter in the determination of reasonableness? Both opinions in *Lifson* discuss weather, natural topographical features and buildings as well as the humans populating the landscape at the time of the accident. Are there no universal rules about conduct without contextual clues?

Note 4. *Lifson* concerns **the sudden emergency doctrine** but other doctrines apply analogous reasoning to ongoing situations. For instance, **the ongoing storm doctrine** may relieve a commercial property owner of the ordinary obligations to clear snow and ice while the storm is still ongoing. It has been rejected in a number of jurisdictions which have held that commercial landowners have a duty to take reasonable steps to make a walkway safe from foreseeable dangers, even during ongoing precipitation.

The doctrine was upheld in New Jersey where at common law, property owners had no duty to clear the public sidewalk adjoining their premises; both commercial and residential property owners were not liable for the condition of the sidewalk. The Supreme Court created an exception to that common-law rule and imposed a duty on commercial property owners to take reasonable measures to maintain the sidewalks adjoining their property and to keep those in reasonably good condition. *Stewart v. 104 Wallace St., Inc.*, 87 N.J. 146, 149, (1981).

In *Pareja v. Princeton*, the plaintiff, Angel Alberto Pareja, was walking to work in the early morning hours. It had been raining “a wintry mix of light rain, freezing rain, and sleet” and the precipitation continued as he walked. He slipped on ice on an unavoidable portion of sidewalk that connects the defendant’s driveway to the road and fell, breaking his hip. The weather reports confirmed freezing rain and temperatures of thirty-two to thirty-three degrees. Princeton’s property maintenance supervisor could not specifically recall whether the corporation had pre-treated the sidewalks that day although that was how they ordinarily prepared for storms since the company maintained two apartment buildings and two offices and thus had responsibility for a significant area of sidewalk and common walkways. The court’s refusal to permit recovery rested on its view of the unreasonableness of a duty to keep the road clear *during* the continued precipitation of a storm:

[C]ommercial landowners do not have the absolute duty, and the impossible burden, to keep sidewalks on their property free from snow or ice during an ongoing storm.” Reversing the lower court, which had imposed a duty of reasonable care, the Supreme Court of New Jersey reasoned that doing so “would create liability for those commercial landowners who “after actual or constructive notice, [fail] to act in a reasonably prudent manner to remove or reduce the foreseeable hazard. [c] But such a duty does not consider the size, resources, and ability of individual commercial landowners or recognize that what may be reasonable for larger commercial landowners may not be reasonable – or even possible – for smaller ones. While we trust juries to uphold their duties to evaluate reasonableness, we do not wish to submit every commercial landowner to litigation when it is not feasible to provide uniform, clear guidance as to what would be reasonable.” *Pareja v. Princeton Int’l Properties*, No. 084394, 2021 WL 2371260, at *6–7 (N.J. June 10, 2021)

In a footnote, the court adds: “The dissent suggests that all a landlord need do to avoid liability is to take such a simple measure as spreading salt. This ignores the diversity of storms a landlord may confront and that measures like spreading salt in a heavy snowstorm or ice storm can be ineffective or even enhance the danger, thus imposing an untenable duty of care on landlords.” It concludes: “We decline to impose a duty that cannot be adhered to by all commercial landowners.” The court distinguishes between the different capacities of smaller and larger businesses, which seems somewhat in tension with the objective nature of the standard of reasonable care. How does it justify its reasoning?

Do the rulings in *Blyth*, *Lifson*, and *Pareja* seem consistent or in tension? How would you seek to reconcile or distinguish them?

Note 5. In some instances, a corporate entity’s *own* protocols specify conduct that the company fails to meet. In such cases, it can be extremely helpful to the plaintiff to locate the relevant protocols during discovery and use them as evidence that even the defendant didn’t believe it was appropriate to do or to fail to do some act. Might this create perverse incentives to refrain from specifying particular protocols? What do you think are the advantages of formulating specific policies versus maintaining only general internal guidelines, or having none at all?

Check Your Understanding (3-4)

Question 1. *Lifson's* majority opinion most accurately stands for the proposition that:

An interactive H5P element has been excluded from this version of the text. You can view it online here: <https://saidtorts2d.lawbooks.cali.org/?p=57#h5p-68>

Question 2. Which of the following scenarios (loosely adapted from the cases in this unit), is likeliest to give rise to a finding of breach of duty by Manny?

An interactive H5P element has been excluded from this version of the text. You can view it online here: <https://saidtorts2d.lawbooks.cali.org/?p=57#h5p-69>

Lubitz v. Wells, Superior Court of Connecticut (1955) (19 Conn. Supp. 322)

The complaint alleges that James Wells was the owner of a golf club and that he left it for some time lying on the ground in the backyard of his home. That thereafter his son, the defendant James Wells, Jr., aged eleven years, while playing in the yard with the plaintiff, Judith Lubitz, aged nine years, picked up the golf club and proceeded to swing at a stone lying on the ground. In swinging the golf club, James Wells, Jr., caused the club to strike the plaintiff about the jaw and chin.

Negligence alleged against the young Wells boy is that he failed to warn his little playmate of his intention to swing the club and that he did swing the club when he knew she was in a position of danger. In an attempt to hold the boy's father, James Wells, liable for his son's action, it is alleged that James Wells was negligent because although he knew the golf club was on the ground in his backyard and that his children would play with it, and that although he knew or 'should have known' that *323 the negligent use of the golf club by children would cause injury to a child, he neglected to remove the golf club from the backyard or to caution James Wells, Jr., against the use of the same.

The demurrer challenges the sufficiency of the allegations of the complaint to state a cause of action or to support a judgment against the father, James Wells.

It would hardly be good sense to hold that this golf club is so obviously and intrinsically dangerous that it is negligence to leave it lying on the ground in the yard. The father cannot be held liable on the allegations of this complaint. [c]

The demurrer is sustained.

Note 1. What conduct would need to be evaluated for a negligence action against the father versus a claim against the son?

Note 2. What was the untaken precaution in this case, if any? What facts would you change to create a clear negligence action against the father?

Applying the Reasonable Person Standard

Roberts v. State of Louisiana, Court of Appeal of Louisiana (1981) (396 So.2d 566)

In this tort suit, William C. Roberts sued to recover damages for injuries he sustained in an accident in the lobby of the U. S. Post Office Building in Alexandria, Louisiana. Roberts fell after being bumped into by Mike Burson, the blind operator of the concession stand located in the building. Plaintiff sued the State of Louisiana, through the Louisiana Health and Human Resources Administration, advancing two theories of liability: respondeat superior and negligent failure by the State to properly supervise and oversee the safe operation of the concession stand.⁹³ The stand's *567 blind operator, Mike Burson, is not a party to this suit although he is charged with negligence.

The trial court order plaintiff's suit dismissed holding that there is no respondeat superior liability without an employer-employee relationship and that there is no negligence liability without a cause in fact showing. We affirm the trial court's decision for the reasons which follow.

On September 1, 1977, at about 12:45 in the afternoon, operator Mike Burson left his concession stand to go to the men's bathroom located in the building. As he was walking down the hall, he bumped into plaintiff who fell to the floor and injured his hip. Plaintiff was 75 years old, stood 5'6 and weighed approximately 100 pounds. Burson, on the other hand, was 25 to 26 years old, stood approximately 6' and weighed 165 pounds. At the time of the incident, Burson was not using a cane nor was he utilizing the technique of walking with his arm or hand in front of him. Even though Burson was not joined as a defendant, his negligence or lack thereof is crucial to a determination of the State's liability. Because of its importance, we begin with it. Plaintiff contends that operator Mike Burson traversed the area from his concession stand to the men's bathroom in a negligent manner. To be more specific, he focuses on the operator's failure to use his cane even though he had it with him in his concession stand.

In determining an actor's negligence, various courts have imposed differing standards of care to which handicapped persons are expected to perform. Professor William L. Prosser expresses one generally recognized modern standard of care as follows:

“As to his physical characteristics, the reasonable man may be said to be identical with the actor. The man who is blind ... is entitled to live in the world and to have allowance made by others for his disability, and he cannot be required to do the impossible by conforming to physical standards which he cannot meet ... At the same time, the conduct of the handicapped individual must be reasonable in the light of his knowledge

⁹³ The United States of America was also originally made defendant but was dismissed without prejudice early in this suit on motion of plaintiff's counsel.

of his infirmity, which is treated merely as one of the circumstances under which he acts ... It is sometimes said that a blind man must use a greater degree of care than one who can see; but it is now generally agreed that as a fixed rule this is inaccurate, and that the correct statement is merely that he must take the precautions, be they more or less, which the ordinary reasonable man would take if he were blind.” W. Prosser, *The Law of Torts*, Section 32, at Page 151-52 (4th ed. 1971).

A careful review of the record in this instance reveals that Burson was acting as a reasonably prudent blind person would under these particular circumstances.

Mike Burson is totally blind. Since 1974, he has operated the concession stand located in the lobby of the post office building. It is one of twenty-three vending stands operated by blind persons under a program funded by the federal government and implemented by the State through the Blind Services Division of the Department of Health and Human Resources. Burson hired no employees, choosing instead to operate his stand on his own.

Prior to running the vending stand in Alexandria, Burson attended Arkansas Enterprises for the blind where he received mobility training. In 1972, he took a refresher course in mobility followed by a course on vending stand training. In that same year, he operated a concession stand in Shreveport, his first under the vending stand program. He later operated a stand at Centenary before going to Alexandria in 1974 to take up operations there. On the date of the incident in question, Mike Burson testified that he left his concession stand and was on his way to the men’s bathroom when he bumped into plaintiff. He, without hesitancy, admitted that at the time he was not using his cane, explaining that he relies on his facial sense which he feels is an adequate technique for *568 short trips inside the familiar building. Burson testified that he does use a cane to get to and from work.

Plaintiff makes much of Burson’s failure to use a cane when traversing the halls of the post office building. Yet, our review of the testimony received at trial indicates that it is not uncommon for blind people to rely on other techniques when moving around in a familiar setting. For example George Marzloff, the director of the Division of Blind Services, testified that he can recommend to the blind operators that they should use a cane but he knows that when they are in a setting in which they are comfortable, he would say that nine out of ten will not use a cane and in his personal opinion, if the operator is in a relatively busy area, the cane can be more of a hazard than an asset. Mr. Marzloff further testified that he felt a reasonably functioning blind person would learn his way around his work setting as he does around his home so that he could get around without a cane. Mr. Marzloff added that he has several blind people working in his office, none of whom use a cane inside that facility.

Mr. Marzloff’s testimony is similar to testimony received from Guy DiCharry, a blind business enterprise counselor with the Blind Services Division. As part of his responsibilities Mr. DiCharry supervised the Alexandria vending stand providing him with an opportunity to observe Mike Burson in a work setting. He testified that Burson knew his way around the building pretty well and that like most of his other blind operators, he did not use a cane on short trips within the building. He added that he discussed the use of a cane on such short trips as these with some of his other blind operators but they took offense to his suggestions, explaining that it was their choice. The only testimony in the record that suggests that Burson traversed the halls in a negligent manner was that elicited from plaintiff’s expert witness, William Henry Jacobson. Jacobson is an instructor in peripathology, which he explained as the science of movement within the surroundings by visually impaired individuals.

Jacobson, admitting that he conducted no study or examination of Mike Burson's mobility skills and that he was unfamiliar with the State's vending program, nonetheless testified that he would require a blind person to use a cane in traversing the areas outside the concession stand. He added that a totally blind individual probably should use a cane under any situation where there is an unfamiliar environment or where a familiar environment involves a change, whether it be people moving through that environment or strangers moving through that environment or just a heavy traffic within that environment.

When cross examined however, Jacobson testified:

"Q. Now, do you, in instructing blind people on their mobility skills, do you tell them to use their own judgment in which type of mobility assistance technique they're to employ?

A. Yes I do.

Q. Do you think that three (3) years is a long enough period for a person to become acquainted with an environment that he might be working with?

A. Yes I do.

Q. So you think that after a period of three (3) years an individual would probably, if he is normal ... has normal mobility skills for a blind person, would have enough adjustment time to be ... to call that environment familiar?

A. Yes.

Q. That's not including the fact that there may be people in and out of the building?

A. Right.

Q. Now is it possible that if he's familiar with the sounds of the people inside a building that he may even at some point in time become so familiar with the people in an area, regular customers or what not that you could *569 say that the environment was familiar, including the fact that there are people there, is that possible?

A. Uh ... I would hesitate to say that, in a public facility where we could not ... uh ... control strangers coming in.

Q. Well, let's say that a business has a particular group of clients that are always there, perhaps on a daily or weekly basis. Now you've stated that a blind person sharpens his auditory skills in order to help him articulate in an area?

A. With instruction, yes.

Q. Right. Isn't it possible that if he can rely on a fixed travel of a fixed type and number of persons that it's possible that that is a familiar environment even though there are people there?

A. Only if they were the same people all the time and they know him, yes."

Upon our review of the record, we feel that plaintiff has failed to show that Burson was negligent. Burson testified that he was very familiar with his surroundings, having worked there for three and a half years. He had special mobility training and his reports introduced into evidence indicate good mobility skills. He explained his decision to rely on his facial sense instead of his cane for these short trips in a manner which convinces us that it was a reasoned decision. Not only was Burson's explanation adequate, there was additional testimony from other persons indicating that such a decision is not an unreasonable one. Also important is the total lack of any evidence in the record showing that

at the time of the incident, Burson engaged in any acts which may be characterized as negligence on his part. For example, there is nothing showing that Burson was walking too fast, not paying attention, et cetera. Under all of these circumstances, we conclude that Mike Burson was not negligent.

Our determination that Mike Burson was not negligent disposes of our need to discuss liability on the part of the State.

For the above and foregoing reasons, the judgment of the trial court dismissing plaintiff's claims against defendant is affirmed and all costs of this appeal are assessed against the plaintiff-appellant.

Note 1. Do you understand the legal principles embedded in the court's statement that "there is no respondeat superior liability without an employer-employee relationship and that there is no negligence liability without a cause in fact showing?"

Note 2. The court makes an effort to respect the autonomy of Mr. Burson as a blind man with considerable experience on the job and a great deal of comfort in his navigation of his workplace. Generally, is there a tension in applying the reasonable person standard (objectively) –albeit with modifications based on ability or disability– and respecting the rights of individuals to make choices they believe are reasonable (subjectively)? Why or why not? Is the standard inescapably ableist, or is it capable of (perhaps already succeeding in) reflecting a progressive view on differing abilities, by simply allowing category-wide modifications? Is this a system-wide issue in tort law that comes along with using objective versus subjective standards for conduct?

Robinson v. Lindsay, Supreme Court of Washington (1979) (92 Wash.2d 410)

UTTER, CHIEF JUSTICE.

[Billy Anderson, age 13 years, was driving a snowmobile belonging to defendant Lindsay, pulling plaintiff Kelly Robinson on an innertube attached to the snowmobile. Plaintiff's thumb was severed when it was caught in the tow rope. The thumb was reattached, but still not fully functional at the time of trial. Plaintiff filed suit against Billy Anderson and Lindsay, the owner of the snowmobile.]

An action seeking damages for personal injuries was brought on behalf of Kelly Robinson who lost full use of a thumb in a snowmobile accident when she was 11 years of age. The petitioner, Billy Anderson, 13 years of age at the time of the accident, was the driver of the snowmobile. After a jury verdict in favor of Anderson, the trial court ordered a new trial. The single issue on appeal is whether a minor operating a snowmobile is to be held to an adult standard of care. The trial court failed to instruct the jury as to that standard and ordered a new trial because it believed the jury should have been so instructed. We agree and affirm the order granting a new trial.

The trial court instructed the jury under WPI 10.05 that:

“In considering the claimed negligence of a child, you are instructed that it is the duty of a child to exercise the same care that a reasonably careful child of the same age,

intelligence, maturity, training and experience would exercise under the same or similar circumstances.”

Respondent properly excepted to the giving of this instruction and to the court’s failure to give an adult standard of care. The question of what standard of care should apply to acts of children has a long historical background. Traditionally, a flexible standard of care has been used to determine if children’s actions were negligent. Under some circumstances, however, courts have developed a rationale for applying an adult standard. In the courts’ search for a uniform standard of behavior to use in determining whether or not a person’s conduct has fallen below minimal acceptable standards, the law has developed a fictitious person, the “reasonable man of ordinary prudence.”

That term was first used in *Vaughan v. Menlove*, 132 Eng.Rep. 490 (1837). Exceptions to the reasonable person standard developed when the individual whose conduct was alleged to have been negligent suffered from some physical impairment, such as blindness, deafness, or lameness. Courts also found it necessary, as a practical matter, to depart considerably from the objective standard when dealing with children’s behavior. Children are traditionally encouraged to pursue childhood activities without the same burdens and responsibilities with which adults must contend. [C] As a result, courts evolved a special standard of care to measure a child’s negligence in a particular situation.

In *Roth v. Union Depot Co.*, 13 Wash. 525, (1896), Washington joined “the overwhelming weight of authority” in distinguishing between the capacity of a child and that of an adult. As the court then stated, at page 544:

“[I]t would be a monstrous doctrine to hold that a child of inexperience—and experience can come only with years—should be held to the same degree of care in avoiding danger as a person of mature years and accumulated experience.”

The court went on to hold, at page 545, 43 P. at page 647:

“The care or caution required is according to the capacity of the child, and this is to be determined, ordinarily, by the age of the child. ... [A] child is held ... only to the exercise of such degree of care and discretion as is reasonably to be expected from children of his age.” [***] In the past we have always compared a child’s conduct to that expected of a reasonably careful child of the same age, intelligence, maturity, training and experience. This case is the first to consider the question of a child’s liability for injuries sustained as a result of his or her operation of a motorized vehicle or participation in an inherently dangerous activity.

Courts in other jurisdictions have created an exception to the special child standard because of the apparent injustice that would occur if a child who caused injury while engaged in certain dangerous activities were permitted to defend himself by saying that other children similarly situated would not have exercised a degree of care higher than his, and he is, therefore, not liable for his tort. Some courts have couched the exception in terms of children engaging in an activity which is normally one for adults only. See, e.g., *Dellwo v. Pearson*, 259 Minn. 452 (1961) (operation of a motorboat).

We believe a better rationale is that when the activity a child engages in is inherently dangerous, as is the operation of powerful mechanized vehicles, the child should be held to an adult standard of care. Such a rule protects the need of children to be children but at the same time discourages immature

individuals from engaging in inherently dangerous activities. Children will still be free to enjoy traditional childhood activities without being held to an adult standard of care. Although accidents sometimes occur as the result of such activities, they are not activities generally considered capable of resulting in “grave danger to others and to the minor himself if the care used in the course of the activity drops below that care which the reasonable and prudent adult would use...” *Daniels v. Evans*, 107 N.H. 407, 408 (1966).

Other courts adopting the adult standard of care for children engaged in adult activities have emphasized the hazards to the public if the rule is otherwise. We agree with the Minnesota Supreme Court’s language in its decision in *Dellwo v. Pearson*, *supra*, 259 Minn. at 457–58: “Certainly in the circumstances of modern life, where vehicles moved by powerful motors are readily available and frequently operated by immature individuals, we should be skeptical of a rule that would allow motor vehicles to be operated to the hazard of the public with less than the normal minimum degree of care and competence.” *Dellwo* applied the adult standard to a twelve-year-old defendant operating a motor boat. Other jurisdictions have applied the adult standard to minors engaged in analogous activities. *Goodfellow v. Coggburn*, 98 Idaho 202, 203–04 (1977) (minor operating tractor); *Williams v. Esaw*, 214 Kan. 658, 668, (1974) (minor operating motorcycle); *Perricone v. DiBartolo*, 14 Ill.App.3d 514, 520 (1973) (minor operating gasoline-powered minibike); *Krahn v. LaMeres*, 483 P.2d 522, 525–26 (Wyo.1971) (minor operating automobile). The holding of minors to an adult standard of care when they operate motorized vehicles is gaining approval from an increasing number of courts and commentators. [cc] The operation of a snowmobile likewise requires adult care and competence. Currently 2.2 million snowmobiles are in operation in the United States. 9 *Envir. Rptr.* (BNA) 876 [1978 Current Developments].

Studies show that collisions and other snowmobile accidents claim hundreds of casualties each year and that the incidence of accidents is particularly high among inexperienced operators. [c] At the time of the accident, the 13-year-old petitioner had operated snowmobiles for about 2 years. When the injury occurred, petitioner was operating a 30-horsepower snowmobile at speeds of 10–20 miles per hour. The record indicates that the machine itself was capable of 65 miles per hour. Because petitioner was operating a powerful motorized vehicle, he should be held to the standard of care and conduct expected of an adult.

The order granting a new trial is affirmed.

Note 1. The standard is typically reformulated along the lines of “what it is reasonable to expect of children of like age, intelligence and experience.” *See* Restatement (Second) of Torts § 283A and Restatement (Third) of Torts: Liability for Physical and Emotional Harm § 10 (2010). What do you think of the inclusion of “intelligence” in this formulation?

Note 2. Do you think that local customs and mores should play a role in determining what counts as an adult activity? In the mountain states, the driving age is lower, partly as a consequence of the need to drive tractors and farm vehicles, and the operation of vessels on the water in areas surrounded by water may be much more common at a younger age in places like Washington State, Hawaii, Michigan or states in which life takes place around and on lakes, perhaps using fishing for sustenance. In one jurisdiction, deer hunting is considered an activity fit for children, thus subjecting the activity to the lower standard of care applicable to a child. What do you think of such a determination, and what do you think it might reflect? What sorts of evidence would you seek of what is ordinarily done, or known,

in a given community? The next case takes up the question of custom evidence as a means of proving the breach element of the defendant's conduct.

Note 3. Critiques of the “Objective” Standard. Professor Richard Delgado, one of the pioneers of critical race theory and “LatCrit” studies, has critiqued the allegedly objective nature of the objective standard in law.

[I]n many areas the law prefers “objective” over “subjective” standards for judging conduct. ...Where does this preference come from, and what does it say about ourselves and our legal culture? Does the objective-subjective distinction hold up under analysis? When we rehearse the familiar arguments in favor of one approach or the other,[fn] what are we doing, and what is at stake? ... [I]n many cases it is the stronger party... that wants to apply an objective standard to a key event. ... Powerful actors ... want objective standards applied to them simply because these standards always, and already, reflect them and their culture. These actors have been in power; their subjectivity long ago was deemed “objective” and imposed on the world. ...It is no surprise, then, that judgment under an “objective” (or reasonable person) standard generally will favor the stronger party.

Richard Delgado, *Shadowboxing: An Essay on Power*, 77 Cornell L. Rev. 813, 818 (1992)

What do you think of Professor Delgado's arguments about the nature of power and the role it may play in shaping our understanding of what is “reasonable”? In some instances, courts have attempted to tailor the standard or make incremental changes to the case law. For instance, in the context of sexual harassment, one court shifted from a reasonableness standard about a hostile workplace explicitly to focus on the victim's perspective, reasoning that “[a] complete understanding of the victim's view requires, among other things, an analysis of the different perspectives of men and women. Conduct that many men consider unobjectionable may offend many women... We adopt the perspective of a reasonable woman primarily because we believe that a sex-blind reasonable person standard tends to be male-biased and tends to systematically ignore the experiences of women. The reasonable woman standard does not establish a higher level of protection for women than men... By acknowledging and not trivializing the effects of sexual harassment on reasonable women, courts can work towards ensuring that neither men nor women will have to “run a gauntlet of sexual abuse in return for the privilege of being allowed to work and make a living.” *Ellison v. Brady*, 924 F.2d 872, 878, 880-881 (9th Cir. 1991).

In the 21st century, using gender categories so blithely may no longer be considered as helpful as it once was; indeed some may find *Ellison* inappropriate or even harmful in its construction of gender in starkly binary terms. Yet this only underscores how dynamic tort law can and must be in recognizing changes in behavior and understanding fluid social constructs such as gender.

Note 4. Objective Reasonableness and Informed Consent. Delgado's article [*Shadowboxing: An Essay on Power*, 77 Cornell L. Rev. 813 (1992)] offers three contexts in which to explore the question, including informed consent by medical providers. You may recall *Cobbs v. Grant* from Module 1, one of the earliest informed consent cases, which Delgado discusses in his article. He writes:

Before performing medical operations or other invasive procedures, doctors must communicate to the patient what a *reasonable person* would want to know about the

material risks and benefits of the procedure... It is immaterial whether the patient has an undisclosed or highly personalized fear or preference that, if known, would have called for further information or a different course of action. The law requires only the doctor's initial disclosure of "objective" information. [I]t is the rare doctor who asks the patient about her specific feelings and attitudes toward pain, incapacity, dependency, death, risk aversiveness, reproductive faculties, and religion—a few of the matters that could bear significantly on a medical decision. Answers to these questions might suggest to the doctor the necessity of further discussions with the patient, further disclosures, or a different course of treatment. The case law of informed consent makes clear, however, that the physician's duty to disclose is simpler and more easily satisfied. The leading case in this area, *Cobbs v. Grant*, requires that the doctor disclose to the patient the reasonable risks and complications of the contemplated procedure and, beyond this, what a competent member of the medical community would disclose. Although more exacting standards have been proposed, they are not yet the law. *Id.* At 818 (emphasis added; internal citations omitted).

What do you think of Delgado's arguments about the objective standard in the context of medical treatment? Do your views of the nature of "reasonableness" differ based on the contexts in which the standards may be used?

Note 5. Angela Onwuachi-Willig, has argued that a more finegrained and intersectional approach is necessary for greater equality and inclusion:

[C]ourts should employ a standard based on a reasonable person *in the complainant's intersectional and multidimensional shoes*, rather than the ostensibly objective reasonable person standard—which some courts have declared to be male biased—when evaluating sexual harassment claims. Although many authors have argued for adopting a reasonable woman standard in harassment law, none have taken the further step of contending that the standard must also be rooted in an intersectional and multidimensional lens in order to capture the different ways that women across intersectional categories may experience any particular event or events. ...Currently, antidiscrimination law employs what courts deem an objective victim standard to analyze sexual harassment claims. In so doing, the law ignores the complexities of how gender and racial subordination, stereotype, and bias can shape a victim's vulnerability to harassment, her credibility in the eyes of factfinders, and others' perceptions about whether she is harmed by the undesired conduct. It also disregards how a complainant's own understanding of others' perceptions about her group or groups, whether based on race, sex, or other identity factors like religion and age, can shape her own response to the harassment she is enduring. By adopting a standard based on a reasonable person with the complainant's intersectional and multidimensional identity, courts can acknowledge how the current standard, though allegedly objective, is actually rooted in the experiences of white men, particularly because the case law has largely been developed by white male judges.

What About #UsToo?: The Invisibility of Race in the #MeToo Movement, 128 Yale L.J. F. 105, 108 (2018) (internal citations omitted). If we take Onwuachi-Willig's suggestion seriously, what might this require in the profession? Can judges and clerks working on cases, and lawyers advocating for clients

adopt intersectional perspectives even as the legal profession works, slowly, to try to achieve greater institutional diversity? Is the jury a help or a hindrance in this regard? Should demographic evidence be used to shape the objective standard, regardless of the identities of the decisionmakers? When tailoring an objective standard to reflect some of the identity markers of the party to whom it applies, at what point does it transform from objective into subjective?

Note 6. Combined Uses of Objective and Subjective Standards. In one context, the Supreme Court has aimed for a balance by using both standards: “Title VII is violated when the workplace is permeated with discriminatory behavior that is sufficiently severe or pervasive to create a discriminatorily hostile or abusive working environment ... This standard requires an **objectively** hostile or abusive environment—one that a reasonable person would find hostile or abusive—as well as the victim’s **subjective** perception that the environment is abusive.” *Harris v. Forklift Sys., Inc.*, 510 U.S. 17, 114 S. Ct. 367, 368, 126 L. Ed. 2d 295 (1993)

As you learned in *Ali v. Margate*, however, employment discrimination claims are notoriously difficult to win. As you continue to learn about the way tort claims and defenses are structured and litigated, keep in mind the use of objective and subjective standards as well as the ways they work and for whom.

Check Your Understanding (3-5)

Question 1. Which of the following is an accurate statement of the rule in *Robinson v. Lindsay*:

An interactive H5P element has been excluded from this version of the text. You can view it online here: <https://saidtorts2d.lawbooks.cali.org/?p=57#h5p-70>

Reflect On Your Understanding – Essay

What would it look like for tort law to use a different standard in place of objective reasonableness? What costs and benefits would flow to the system? What values would you prioritize in redesigning a system?

Chapter 17. Negligence: Policy Considerations Regarding Duty and Breach (Socratic Script)

Alvarado is a viscerally-disturbing case, or so some may find. In its reliance on *Palsgraf*, it provides a review of duty and breach as well as an opportunity to think about the implications of following different legal rules (such as the majority and dissenting opinions in *Palsgraf*).

Questions or Areas of Focus for the Readings

- What are the untaken precautions here?
- What are the social justice implications of finding or denying liability on these facts?
- Are there parties you would have liked to be able to reach (either intuitively, or normatively) to extend liability or to allocate it better?
- Do you see the difficulties involved with separating *duty* from *breach* in some instances?

Alvarado v. Sersch, Supreme Court of Wisconsin (2003) **(262 Wis.2d 74)**

The petitioners, Dora Alvarado and her four minor children, seek review of a published court of appeals decision affirming a circuit court grant of summary judgment in favor of the respondents, Oakbrook Corporation, Meriter Retirement Services, Inc., and Meriter's insurer. [fn] Alvarado asserts that the court of appeals erred in using public policy factors to limit liability before all the facts were considered. Because we conclude that there are genuine issues of material fact, we determine that the court of appeals erred when it affirmed the grant of summary judgment limiting liability based on public policy factors. Accordingly, we reverse the court of appeals and remand the action to the circuit court for further proceedings.

*79 Meriter Retirement Services, Inc. (Meriter) owns student apartments in Madison that are managed by Oakbrook Corporation (Oakbrook). On August 12, 1998, during the busy student turnover period, Oakbrook's property manager walked through a vacated apartment to inspect the premises. In his deposition he testified that "cabinets" were on his checklist, but he did not remember checking them. On August 13, 1998, a painting crew entered the apartment. One of the painters discovered what he believed to be a "candle" in the kitchen cabinet. Another painter recognized it as a firework device. They moved the item out of the way and continued working. No one in the crew informed Oakbrook or Meriter about the firework.

On August 14, 1998, Dora Alvarado and Ron Boehm, the owner of the janitorial service retained by Oakbrook, entered the apartment to clean it. Alvarado had already completed a ten-to eleven-hour shift that day, but had been called back to work. Boehm noticed what he thought to be a candle on the windowsill. He commented to Alvarado that it was a "strange looking candle." It was described as a wax candle with red, white, and blue colors, about six inches tall, and an inch in diameter. After Boehm

left the apartment, Alvarado began cleaning the interior of the gas stove. She opened the stovetop to expose the burner trays for vacuuming. Alvarado knew it was necessary to preserve the flame of the pilot light, which occasionally extinguished during the cleaning process. Because she had forgotten to bring matches, she decided to use the “candle” to preserve the flame, and lit the device with the pilot *80 flame. The firework exploded as she was setting it down, blowing off most of her right hand.

Alvarado and her children filed a complaint in Dane County circuit court against Meriter, Oakbrook, the painting contractor, and each of their insurers. The plaintiffs sought damages as a result of Alvarado’s personal injuries. The circuit court granted Oakbrook and Meriter’s motion for summary judgment. It concluded that Oakbrook and Meriter did not have a duty of care to protect Alvarado from a potential harm they neither knew nor reasonably could have foreseen.

The court of appeals affirmed the circuit court’s grant of summary judgment for Oakbrook and Meriter, but employed a different rationale. Rather than focusing on negligence, the court of appeals considered public policy factors that limit a defendant’s liability. It concluded that the injury was too remote from the negligence, and in retrospect it appeared too highly extraordinary that the negligence should have resulted in the harm. Under this analysis, the court of appeals determined that public policy barred any imposition of liability, and therefore it affirmed the circuit court’s grant of summary judgment.

Alvarado seeks a reversal of the court of appeals’ decision, and a remand for a jury trial. She argues that it was improper for the court of appeals to use public policy considerations to limit liability before all the facts had been presented to a jury for a determination of negligence. She asserts that the grant of summary judgment was error because there remain genuine issues of material fact. [***]

Wisconsin has long followed the minority view of duty set forth in the dissent of *Palsgraf v. Long Island Railroad*. [c] In that dissent, Judge Andrews explained that “[e]veryone owes to the world at large the duty of refraining from those acts that may unreasonably threaten the safety of others.” *Palsgraf v. Long Island R.R. Co.*, 248 N.Y. 339 (1928) (Andrews, J., dissenting). *82 Every person has a duty to use ordinary care in all of his or her activities, and a person is negligent when that person fails to exercise ordinary care. *Gritzner*, 235 Wis.2d 781, ¶¶ 20 & 22. In Wisconsin a duty to use ordinary care is established whenever it is foreseeable that a person’s act or failure to act might cause harm to some other person. *Id.* ¶ 20. Under the general framework governing the duty of care, a “ ‘person is not using ordinary care and is negligent, if the person, without intending to do harm does something (or fails to do something) that a reasonable person would recognize as creating an unreasonable risk of injury or damage to a person or property.’” [c]

The question of duty is nothing more than an “ingredient in the determination of negligence.” [c] Once it has been determined that a negligent act caused the harm, “the question of duty is irrelevant and a finding of nonliability can be made only in terms of public policy.” [c] The “duty” ingredient of negligence should not be confused with public policy limitations on liability. [fn] “[T]he doctrine of public policy, not the doctrine of *83 duty, limits the scope of the defendant’s liability.” [c] “In Wisconsin, one always owes a duty of care to the world at large, which is why ‘[t]he consistent analyses of this court reveal that the question of duty is not an element of the court’s policy determination.’” [cc]

Thus, negligence and liability are distinct concepts. [c] After negligence has been found, a court may nevertheless limit liability for public policy reasons. [cc] The public policy considerations that may preclude liability are:

- (1) the injury is too remote from the negligence;
- (2) the injury is too wholly out of proportion to the tortfeasor's culpability;
- (3) in retrospect it appears too highly extraordinary that the negligence should have resulted in the harm;
- (4) allowing recovery would place too unreasonable a burden on the tortfeasor;
- (5) allowing recovery would be too likely to open the way for fraudulent claims; [or]
- (6) allowing recovery would enter a field that has no sensible or just stopping point.

Gritzner, 235 Wis.2d 781, ¶ 27.

In most cases, the better practice is to submit the case to the jury before determining whether the public policy considerations preclude liability. Only in those cases where the facts are simple to ascertain and the public policy questions have been fully presented may a court review public policy and preclude liability before trial. [Citations omitted]

A jury's determination of negligence includes an examination of whether the defendant's exercise of care foreseeably created an unreasonable risk of harm to others. [c] Public policy factors can also implicate the concept of foreseeability. In a sense, evidence regarding foreseeability can play a dual role. Besides having the aid of the jury's opinion when assessing liability, a judge will also be *85 aided by the facts that were brought to light during the jury trial. Having examined the law, we next apply those principles to the facts in this case.

The court of appeals erred in affirming the summary judgment on public policy grounds. This case requires a full factual resolution before application of a public policy analysis. It is not one of those simple cases where public policy can be used to limit liability before finding negligence. Here, there remain genuine issues of material fact, and public policy factors limiting liability should be considered only after a full resolution of the facts at trial.

It is desirable to have a full trial to precede the court's determination because the issues in this case are complex and the factual connections attenuated. [c] A jury will hear testimony about the standard of care that a reasonable property manager would exercise in inspecting a vacated apartment. Oakbrook and Meriter claim that there was no negligence on their part. Alvarado, however, claims that if Oakbrook had performed a thorough inspection of the apartment, as it should have, then the firework would have been found. In his deposition, Alvarado's expert opines that industry practice is to conduct an adequate inspection before allowing employees and contractors onto the premises. He asserts that ordinary care requires a property manager to have a safety program which anticipates and addresses potential hazards:

“Well, they have a big responsibility in their capacity of managing residential housing.... There's all kinds of things to be considered by a company that—that's in *86 charge of managing property.... I could talk about that for hours, but the main idea is that you have to anticipate potential hazards and deal with them in some way. And having a hazardous material or hazardous item in an apartment is something that they're required to anticipate and have a plan and a program to deal with.”⁹⁴

⁹⁴ Deposition testimony of Frank Burg, P.E., September 29, 2000, p. 34.

This case is similar to *Coffey*, in which this court concluded that a full trial should precede a determination that policy considerations preclude liability based on a negligent inspection. *Coffey*, 74 Wis.2d at 543. In that case, a tenant suffered losses as the result of a fire at its leased premises. The tenant sued a building inspector and the City of Milwaukee claiming that they were negligent because the standpipes necessary to furnish the water to fight fire at the leased premises were defective and had not been properly inspected.

In examining whether public policy considerations should preclude liability, the *Coffey* court determined that a full factual resolution was necessary for a fair and complete evaluation of the policy considerations. The court explained that the case involved the complex issue of municipal tort liability arising out of the alleged negligence of a building inspector in carrying out fire inspections. The court concluded that findings as to actual negligence, damage, and the causal relationship between them would be material and helpful in evaluating the public policy considerations. Accordingly, it refused to preclude liability on public policy grounds prior to a full factual resolution.

***87** Analogous to *Coffey*, this case involves facts that are not simple to ascertain. It addresses the tort liability of property managers arising out of the alleged negligence of an inspector in carrying out apartment inspections. Like *Coffey*, a sufficient factual basis is not presented here for considering, evaluating, and resolving the public policy issues involved. Findings as to actual negligence, damages and the causal relationship between them would be material and helpful in evaluating the public policy considerations.

¶ The parties dispute the purpose of Oakbrook’s inspection. Alvarado claims part of the inspection’s purpose was safety, while Oakbrook contends the inspection was only to note needed repairs, cleaning, and security-deposit withholdings. A jury would hear testimony about what constitutes a proper inspection, and whether Oakbrook’s inspection satisfied that obligation. Ultimately, a jury would have determined whether Oakbrook had instituted adequate safety measures, and whether Oakbrook was negligent for failing to instruct contractors about what procedure to follow when a dangerous object is found.

When the circuit court granted summary judgment in favor of Oakbrook and Meriter, it concluded that Oakbrook and Meriter did not owe Alvarado a duty to exercise ordinary care. However, everyone owes a duty of ordinary care to all persons. The effect of the circuit court’s summary judgment was to limit the imposition of liability. [c]; *Klassa v. Milwaukee Gas Light Co.*, 273 Wis. 176, 183 (1956) (“whenever a court holds that a certain act does not constitute negligence because there was *no duty* owed by the actor to the injured party, although the act complained of caused the injury, such court is making a policy determination”).

***88** Likewise, albeit with a different rationale, the court of appeals limited liability by applying public policy factors. Neither the court of appeals nor the circuit court had the benefit of a full presentation of facts or a jury’s verdict on negligence before limiting liability. Because there remain genuine issues of material fact, summary judgment was erroneously granted.

Summary judgment is uncommon in negligence actions, “because the court ‘must be able to say that no properly instructed, reasonable jury could find, based on the facts presented, that [the defendants] failed to exercise ordinary care.’” [c] The concept of negligence is peculiarly elusive, and requires the trier of fact to pass upon the reasonableness of the conduct in light of all the circumstances, “ ‘even where historical facts are concededly undisputed.’” *Id.* Ordinarily, this is not a decision for the court.

In sum, we determine that there remain genuine issues of material fact. Here, public policy factors limiting liability should be considered only after a full resolution of the facts at trial. The court of appeals erred when it affirmed the grant of summary judgment limiting liability based on public policy factors. Accordingly, we reverse the court of appeals and remand the action to the circuit court for further proceedings.

¶ 32 DIANE S. SYKES, J. (dissenting).

I respectfully *89 dissent. The majority concludes that “the court of appeals erred when it affirmed the grant of summary judgment limiting liability based on public policy factors.” I disagree. The court of appeals properly evaluated the public policy limitations on liability in this case, and properly did so in advance of trial, affirming the circuit court’s order of summary judgment.

As the majority notes, negligence law in Wisconsin is based on the dissent in *Palsgraf v. Long Island R.R. Co.*, 248 N.Y. 339 (1928)(Andrews, J., dissenting), in which Judge Andrews of the New York Court of Appeals described negligence as a breach of the duty shared by all members of society to “refrain[] from those acts that may unreasonably threaten the safety of others.” [c] This is the duty of ordinary care, and it is measured by reference to a “reasonable person” standard, which is applied to evaluate the nature and foreseeability of the risk of harm associated with the conduct in question in order to determine whether a defendant was negligent. [c] [***] *90 The determination of negligence is followed by a determination of causation and damages. [fn] Although these are generally factual questions for the jury, there are some circumstances, not implicated here, under which the determination of negligence involves a mixed question of fact and law. [c]

However, it is not always true that negligence causation damages = liability. Considerations of public policy may preclude the imposition of liability even where the facts establish that a negligent act or omission on the part of the defendant was a cause of the plaintiff’s damages. This is purely a question of law for the court. [c] (“The application of public policy considerations is a function of the court.”); [c] (“A finding of nonliability made in terms of public policy is a question of law which the court alone decides.”).

Accordingly, we observed last term that “in Wisconsin, common law limitations on liability are determined not by reference to the absence of a duty, *91 but as a matter of public policy.” [c] This is because “[a]ll members of society are ‘held, at the very least, to a standard of ordinary care in all activities.’” [c]. This distinction between the determination of negligence and the imposition of liability is consistent with the *Palsgraf* dissent: “As was said by Mr. Justice Holmes many years ago, ‘[t]he measure of the defendant’s duty in determining whether a wrong has been committed is one thing, the measure of liability when a wrong has been committed is another.’” *Palsgraf*, 162 N.E. at 102.

The majority recites the public policy limitations on liability but refuses to apply them, concluding that “[t]his case requires a full factual resolution *92 before application of a public policy analysis.” [***] I disagree.

I recognize that we have said it is usually “better practice” or “generally better procedure” to await resolution of the factual issues in a negligence case before submitting it to public policy analysis. [c] However, we have also said that “[t]he assessment of public policy does not necessarily require a full factual resolution of the cause of action by trial.” [cc] As a further example, in our seminal case on the tort of negligent infliction of emotional distress, we held:

The application of public policy considerations is a function solely of the court. While it is generally better *93 procedure to submit negligence and cause-in-fact issues to the jury before addressing legal cause, that is, public policy issues, ... the circuit court or this court may grant summary judgment on public policy grounds before a trial or a court may bar liability on public policy considerations after trial. When the pleadings present a question of public policy, the court may make its determination on public policy grounds before trial. In contrast, when the issues are complex or the factual connections attenuated, it may be desirable for a full trial to precede the court's determination. [c]

In this case this court is determining public policy considerations before trial because the facts presented are simple, and because the question of public policy is fully presented by the complaint and the motion to dismiss. [c] Thus, it is not uncommon for courts to decide on summary judgment that negligence liability should be limited based upon considerations of public policy. Some cases are factually uncomplicated and fully conducive to a pre-trial legal determination on the applicability of public policy limitations on liability. This is such a case.

The majority's rejection of pre-trial public policy analysis in this case is unwarranted. To the extent that it discourages the lower courts from evaluating public policy liability limitations on motions for summary judgment, it will produce two divergent effects: 1) there will be an increase in unnecessary trials and appeals (where the circuit or appellate courts would otherwise have precluded liability pre-trial but now consider themselves constrained to do it only post-trial *94 because of the majority's decision here); and 2) there will be an expansion of liability (where the circuit or appellate courts consider themselves constrained against precluding liability on public policy grounds because of the presence of a jury verdict on negligence).

While I have no quarrel with the "better practice" general rule noted above, I do not agree that the facts of this case are so complex that the evaluation of public policy limitations on liability must await a jury verdict on negligence, cause-in-fact and damages. Judicial gate-keeping on this potentially dispositive legal issue is extremely important given the breadth and potential reach of the definition of negligence in this state. This was an important part of the *Palsgraf* dissent. What we in Wisconsin refer to as public policy limitations on liability, Judge Andrews catalogued as factors that govern the court's determination of legal or "proximate cause."

Judge Andrews said that the duty of ordinary care is owed to all who might be injured as a consequence of an unreasonably risky (i.e., negligent) act or omission, but he also said "there is one limitation. The damages must be so connected with the negligence that the latter may be said to be the proximate cause of the former." *Palsgraf*, 162 N.E. at 103. The negligence, he said, might be "[a] cause, but not the proximate cause. What we [] mean by the word 'proximate', that because of convenience, of public policy, of a rough sense of justice, the law arbitrarily declines to trace a series of events beyond a certain point. This is not logic. It is practical politics." *Id.* This judicial line-drawing relies upon "common sense" and "fair judgment," and "endeavor[s] to make a rule in each case that will be practical and in keeping with the general understanding of mankind." *Id.* at 104.

Public policy limitations on liability are decided by the court as a matter of law, but the majority nevertheless considers the "jury's opinion" to be an "aid" to the court in making that decision. In this regard, the majority seems to be suggesting that the jury should influence the court's assessment of

whether public policy requires non-liability as a matter of law. Courts decide questions of law independently, without deference to the jury. As a practical matter, however, most judges find it difficult to throw out a jury verdict.

This case is amenable to a pre-trial application of the six-factor public policy analysis. The case is not complex, and the historical facts are undisputed. We do not need a jury verdict on negligence, causation, and damages in order to determine whether public policy requires nonliability as a matter of law. I agree with the court of appeals that the first public policy factor (remoteness) and the third (extraordinary result) preclude liability here, even if a jury were to find causal negligence on the part of the apartment owner and manager. I would also conclude that the second factor (disproportionality of culpability to injury) is implicated in this case.

Dora Alvarado's injury was unquestionably tragic and devastating. But the accident that caused it occurred because she mistook a firework for a candle, and lit that firework in the pilot light of an oven that she was cleaning, in an attempt to preserve the pilot light flame in case it went out while she was vacuuming the oven's interior. As a matter of law, such an injury is too remote from the alleged negligent inspection by the apartment owner and manager, as well as too extraordinary and too disproportionate to that alleged negligence. I would affirm the court of appeals.

***96** I am authorized to state that Justice DAVID T. PROSSER, JR. joins this dissent.

Note 1. Do you think it was reasonable for Alvarado to confuse a firework for a candle? Would your answer be relevant to your assessment of the case? The lower court's ruling included a bit more factual detail that you might find helpful in considering that issue.

Many of the apartments managed by Oakbrook are occupied by University of Wisconsin students. Leases on these apartments generally run from August 15 of one year to August 14 of the next. Each year a high number of the apartments "turn over" during August. As apartments are vacated, an Oakbrook employee *756 walks through the apartments to inspect them for damage and to determine whether any cleaning or repairs are necessary.

In August of 1998, Oakbrook employee Larry Keleher was responsible for overseeing 240 rental units. Between 150 and 175 of these units turned over between August 12 and August 15 of 1998. Oakbrook's "Operating Handbook" instructs employees to inspect apartments "thoroughly" and inspect all areas on a checklist. The checklist includes cabinets. Oakbrook does not have a hazardous materials policy and conducts no safety training for either its employees or its painting or cleaning contractors. Oakbrook's manual does, however, generally advise employees to be safety conscious. Its manual states: "Staff should put safety first at all times. Staff should use common sense to not engage in work which endangers the safety and health of themselves and others." Under the job description for various positions, including "property manager," the manual states: "Continually inspect property and improvements for curb appeal, protection of property value, and potential safety hazards." On August 12, 1998, Keleher conducted a move-out inspection of apartment 303 at Meriter's West Main Street property. There is no evidence of complaints relating to the vacating tenant. During his inspection, Keleher did not see a firework device located in a wall-mounted

cabinet in the kitchen. Keleher does not remember whether he opened any of the cabinets during his inspection.

The next day, August 13, three painters from D.P. Painters entered apartment 303 to paint at Oakbrook's request. While in the kitchen, one of the painters found in the kitchen cabinet what turned out to be an M-250 firework, an explosive device equivalent *757 to one-quarter of a stick of dynamite. The firework was about four inches tall and about an inch in diameter with a wick in the top. Statements regarding its color varied, but there was general agreement that it was white with either red and blue, or red or blue, stripes. At least one of the painters believed that the firework was a candle. Another painter, who had previously seen an M-80 firework, recognized the object to be a firework explosive device. The painters removed the firework from the cabinet, but left it in the apartment and did not notify Oakbrook.

The day after the painters left, August 14, Alvarado and her supervisor, Ron Boehm, employees of a janitorial service employed by Oakbrook, entered and began cleaning apartment 303. Boehm noticed the firework device on the windowsill and said to Alvarado something to the effect: "That's a strange looking candle." Boehm described the device as a wax candle with a red, white, and blue exterior.

Alvarado similarly believed the firework was a candle and decided she could use it to relight the pilot light on a gas stove in the apartment. Alvarado knew that when she cleaned the top of the stove with a vacuum, the vacuum would extinguish the pilot light. She had no matches and decided to light the "candle" from the pilot light, vacuum the oven, and then relight the pilot light with the candle. Alvarado lit the device and it exploded, blowing off most of her right hand. Prior to the accident, Alvarado had no experience with any firework-type device.

During his eleven prior years of employment with Oakbrook, Keleher had not discovered or heard of anyone discovering fireworks in a property managed by Oakbrook, but he did know that hazardous and flammable materials had been found in an occupied apartment *758 in 1996. There is no evidence that any abandoned firework had ever been discovered in a Meriter-owned or Oakbrook-managed apartment. Neither party presented evidence of the frequency with which hazardous materials are left behind by vacating tenants.

Having read these additional facts, do any new questions or factors arise that seem relevant for the court's analysis?

Note 2. In its 2002 ruling, the lower court stresses that its holding is case-specific, and it intends its impact to be narrow.

This case involves a highly unusual *770 cause of an injury to a cleaning person employed by a contractor. We do not hold that landlords have no obligation to assure that apartments are hazard-free prior to the time new tenants take occupancy. Neither do we suggest that landlords never have an obligation to search for hazardous materials. To take one of many possible examples, it might be that a landlord could be found negligent and held liable for failing to inspect for hazards if the landlord knew a

vacating tenant was involved in the reckless use of firearms. Given this knowledge, the landlord might properly be held liable for permitting new tenants with children to take occupancy without a thorough inspection.

Do you think it would have had a narrow impact as applied in practice, had it not been reversed on appeal? From what you understand so far about duty and breach, *should* a ruling pertaining to duty be highly fact-specific? *Alvarado v. Sersch*, 257 Wis. 2d 769-770 (2002), rev'd, 262 Wis. 2d 74.

Note 3. *Should* Alvarado be able to rely on the apartment managers' inspection for hazardous materials before allowing cleaners on the premises? Should the managers be required to provide hazardous materials training to every plumber or electrician or cleaner it hires, just in case they encounter hazardous materials onsite? (The court below formed and answered both of these questions succinctly: "Certainly not.") What do you think it is reasonable for contractors and cleaners to expect under such circumstances? Might your answer depend on whether alternative sources of compensation for injury were available?

Check Your Understanding (3-6)

Question 1. Which of the following is an accurate statement about the court's ruling in *Alvarado v. Sersch* (Supreme Court of Wisconsin 2003)?

An interactive H5P element has been excluded from this version of the text. You can view it online here: <https://saidtorts2d.lawbooks.cali.org/?p=59#h5p-71>

Expand On Your Understanding – Socratic Script: Alvarado v. Sersch (Part 1)

Question 1. Which justice’s view of duty from *Palsgraf* do you see represented in the case? How does *Alvarado* (2003) both build on and extend that reasoning from *Palsgraf*? Find textual evidence for your view in the language of the case.

An interactive H5P element has been excluded from this version of the text. You can view it online here: <https://saidtorts2d.lawbooks.cali.org/?p=59#h5p-72>

Question 2. In Wisconsin, how are duty and public policy formulated in relation to negligence?

An interactive H5P element has been excluded from this version of the text. You can view it online here: <https://saidtorts2d.lawbooks.cali.org/?p=59#h5p-73>

Question 3. The appellate court does not make entirely clear why Ms. Alvarado’s children are parties to the suit. Based on what you have been learning about tort law thus far, can you guess why they are joined?

An interactive H5P element has been excluded from this version of the text. You can view it online here: <https://saidtorts2d.lawbooks.cali.org/?p=59#h5p-74>

Check Your Understanding (3-7)

Question 1. True or false: The dissent in *Alvarado* is worried that narrowing the scope of judicial gatekeeping by rejecting pre-trial public policy analysis could result in a diminution in liability.

An interactive H5P element has been excluded from this version of the text. You can view it online here: <https://saidtorts2d.lawbooks.cali.org/?p=59#h5p-75>

Expand On Your Understanding – Socratic Script: Alvarado v. Sersch (Part 2)

Question 4. What rationales does the dissenting opinion offer for its critique of the majority opinion in *Alvarado*?

An interactive H5P element has been excluded from this version of the text. You can view it online here: <https://saidtorts2d.lawbooks.cali.org/?p=59#h5p-76>

Question 5. Do the dissent's concerns seem plausible to you? What concerns would arise from following the dissent's approach? Normatively, which set of concerns is preferable, assuming no perfect solution is available?

An interactive H5P element has been excluded from this version of the text. You can view it online here: <https://saidtorts2d.lawbooks.cali.org/?p=59#h5p-77>

Question 6. Notice how the dissent describes the facts of the case. How does Justice Sykes' description frame the situation and how is that relevant to her legal analysis?

An interactive H5P element has been excluded from this version of the text. You can view it online here: <https://saidtorts2d.lawbooks.cali.org/?p=59#h5p-78>

Reflect On Your Understanding – Essay

What are the normative implications of a ruling like this one? Consider the industries and sub-industries involved and the different socioeconomic statuses of the various parties. Descriptively, Alvarado is bringing this suit against the owner of the apartment complex. Normatively, do you think it would be preferable if she were able to recover for her injuries directly through her employer (through workers' compensation), or in the alternative, through the retailer of the fireworks/rocket on a theory of absolute or strict liability for explosives? What considerations would shape your thinking on this question? Does Alvarado deserve recovery here regardless of the tort doctrine or mechanism required to produce it? Or do countervailing concerns about the scope of tort liability justify withholding compensation on these facts, as Cardozo would likely have done based on his ruling in *Palsgraf*?

Negligence: Breach (Issues of Proof)

Determining whether conduct was reasonable can involve complicated questions of evidence and proof. In some torts cases, evidence has literally been destroyed in a fire or explosion, thus making the case harder to prove in litigation. In many other cases, there are missing facts or mysteries regarding how an accident came to happen. In a significant number of cases, plaintiffs must resort to using circumstantial evidence to build a case regarding the unreasonableness of the conduct. Over time, certain legal devices have arisen to provide shortcuts or to allow the parties to shift the burden of proof back and forth on certain points. One of these is the admissibility of industry standards or “custom evidence” that tends to establish what others similarly situated believed to be reasonable versus unreasonable.

Trimarco v. Klein, Court of Appeals, New York (1982) (436 N.E.2d 502)

After trial by jury in a negligence suit for personal injuries, the plaintiff, Vincent N. Trimarco, recovered a judgment of \$240,000. A sharply divided Appellate Division, 82 A.D.2d 20, 441 N.Y.S.2d 62, having reversed on the law and dismissed the complaint, our primary concern on this appeal is with the role of the proof plaintiff produced on custom and usage. The ultimate issue is whether he made out a case. The controversy has its genesis in the shattering of a bathtub’s glass enclosure door in a multiple dwelling in July, 1976. Taking the testimony most favorably to the plaintiff, as we must in passing on the presence of a prima facie case, we note that, according to the trial testimony, at the time of the incident plaintiff, the tenant of the apartment in which it happened, was in the process of sliding the door open so that he could exit the tub. It is undisputed that the occurrence was sudden and unexpected and the injuries he received from the lacerating glass most severe.

The door, which turned out to have been made of ordinary glass variously estimated as one sixteenth to one quarter of an inch in thickness, concededly would have presented no different appearance to the plaintiff and his wife than did tempered safety glass, which their uncontradicted testimony shows they assumed it to be. Nor was there any suggestion that defendants ever brought its true nature to their attention.

Undeveloped in the trial record is the source of a hospital record entry which ascribed the plaintiff’s injuries to a “fall through his bathroom glass door”. Obviously, this may have been taken into account by the jury, since its verdict called for a reduction of its \$400,000 gross assessment of damages by 40% to account for contributory negligence.⁹⁵

As part of his case, plaintiff, with the aid of expert testimony, developed that, since at least the early 1950’s, a practice of using shatterproof glazing materials for bathroom enclosures had come into common use, so that by 1976 the glass door here no longer conformed to accepted safety standards. *504 This proof was reinforced by a showing that over this period bulletins of nationally recognized safety and consumer organizations along with official Federal publications had joined in warning of the dangers that lurked when plain glass was utilized in “hazardous locations”, including

⁹⁵ The chart had been put in evidence in unredacted form as part of the plaintiff’s medical proof.

“bathtub enclosures”.⁹⁶ [***] And, on examination of the defendants’ managing agent, who long had enjoyed extensive familiarity with the management of multiple dwelling units in the New York City area, plaintiff’s counsel elicited agreement that, since at least 1965, it was customary for landlords who had occasion to install glass for shower enclosures, whether to replace broken glass or to comply with the request of a tenant or otherwise, to do so with “some material such as plastic or safety glass”.

In face of this record, in essence, the rationale of the majority at the Appellate Division was that, “assuming that there existed a custom and usage at the time to substitute shatterproof glass” and that this was a “better way or a safer method of enclosing showers” (82 A.D.2d, p. 23, 441 N.Y.S.2d 62), unless prior notice of the danger came to the defendants either from the plaintiff or by reason of a similar accident in the building, no duty devolved on the defendants to replace the glass either under the common law or under section 78 of the Multiple Dwelling Law.⁹⁷ [***]

Which brings us to the well-recognized and pragmatic proposition that when “certain dangers have been removed by a customary way of doing things safely, this custom may be proved to show that [the one charged with the dereliction] has fallen below the required standard.” [c] Such proof, of course, is not admitted in the abstract. It must bear on what is reasonable conduct under all the circumstances, the quintessential test of negligence.

It follows that, when proof of an accepted practice is accompanied by evidence that the defendant conformed to it, this may establish due care (*Bennett v. Long Is. R. R. Co.*, 163 N.Y. 1, 4 [custom not to lock switch on temporary railroad siding during construction]), and, contrariwise, when proof of a customary practice is coupled with a showing that it was ignored and that this departure was a proximate cause of the accident, it may serve to establish liability (*Levine v. Blaine Co.*, 273 N.Y. 386, 389 [custom to equip dumbwaiter with rope which does not splinter]). Put more conceptually, proof of a common practice aids in “formulat[ing] the general expectation of society as to how individuals will act in the course of their undertakings, and thus to guide the common sense or expert intuition of a jury or commission when called on to judge of particular conduct under particular circumstances” (Pound, *Administrative Application of Legal Standards*, 44 ABA Rep. 445, 456–457).

The source of the probative power of proof of custom and usage is described differently by various authorities, but all agree on its potency. Chief among the rationales offered is, of course, the fact that it reflects the judgment and experience and conduct of many (2 Wigmore, *Evidence* [3d ed.], § 461; Prosser, *Torts* [4th ed.], § 33). Support for its relevancy and reliability comes too from the direct bearing it has on feasibility, for its focusing is on the practicality of a precaution in actual operation and the readiness with which it can be employed (Morris, *Custom and Negligence*, *506 42 Col. L. Rev. 1147, 1148). Following in the train of both of these boons is the custom’s exemplification of the opportunities it provides to others to learn of the safe way, if that the customary one be. (See Restatement, *Torts* 2d, § 295A, Comments *a, b.*)

⁹⁶ The organizations included the National Safety Council, the American National Standards Institute and the Consumer Safety Commission. One of the governmental publications, issued by the United States Health Department, was entitled *Glass Door Injuries and Their Control* and another, emanating from the United States Product Safety Commission, was entitled *Hazard Analysis—Injuries Involving Architectural Glass*.

⁹⁷ Subdivision 1 of section 78 of the Multiple Dwelling Law provides: “Every multiple dwelling * * * and every part thereof * * * shall be kept in good repair. The owner shall be responsible for compliance with the provisions of this section”.

From all this it is not to be assumed customary practice and usage need be universal. It suffices that it be fairly well defined and in the same calling or business so that “the actor may be charged with knowledge of it or negligent ignorance” (Prosser, Torts [4th ed.], § 33, p. 168; Restatement, Torts 2d, § 295A, p. 62, Comment *a*).

However, once its existence is credited, a common practice or usage is still not necessarily a conclusive or even a compelling test of negligence (1 Shearman & Redfield, Negligence [rev ed], § 10). Before it can be, the jury must be satisfied with its reasonableness, just as the jury must be satisfied with the reasonableness of the behavior which adhered to the custom or the unreasonableness of that which did not (see *Shannahan v. Empire Eng. Corp.*, 204 N.Y. 543, 550). After all, customs and usages run the gamut of merit like everything else. That is why the question in each instance is whether it meets the test of reasonableness. As Holmes’ now classic statement on this subject expresses it, “[w]hat usually is done may be evidence of what ought to be done, but what ought to be done is fixed by a standard of reasonable prudence, whether it usually is complied with or not” (*Texas & Pacific Ry. Co. v. Behymer*, 189 U.S. 468, 470).

So measured, the case the plaintiff presented, even without the [Editor’s insertion: improperly admitted evidence concerning a statute that applied to *new* installations of glass and not existing glass] *** was enough to send it to the jury and to sustain the verdict reached. The expert testimony, the admissions of the defendant’s manager, the data on which the professional and governmental bulletins were based, the evidence of how replacements were handled by at least the local building industry for the better part of two decades, these in the aggregate easily filled that bill. Moreover, it was also for the jury to decide whether, at the point in time when the accident occurred, the modest cost and ready availability of safety glass and the dynamics of the growing custom to use it for shower enclosures had transformed what once may have been considered a reasonably safe part of the apartment into one which, in the light of later developments, no longer could be so regarded.

Furthermore, the charge on this subject was correct. The Trial Judge placed the evidence of custom and usage “by others engaged in the same business” in proper perspective, when, among other things, he told the jury that the issue on which it was received was “the reasonableness of the defendant’s conduct under all the circumstances”. He also emphasized that the testimony on this score was not conclusive, not only by saying so but by explaining that “the mere fact that another person or landlord may have used a better or safer practice does not establish a standard” and that it was for the jurors “to determine whether or not the evidence in this case does establish a general custom or practice”.

Nevertheless, we reverse and order a new trial because the General Business Law sections [on future installations] should have been excluded. True, if a statutory scheme intended for the protection of a particular class, as is the one here, does not expressly provide for civil liability, there is responsible authority for the proposition that a court may, in furtherance of the statutory purpose, read in such an intent (see *Martin v. Herzog*, 228 N.Y. 164, 168; Restatement, Torts 2d, § 286; see, generally, James, Statutory Standards and Negligence in Accident Cases, 11 La. L. Rev. 95). Be that as it may, the fact is that the statutes here protected only those tenants for whom shower glazing was installed after the statutory effective date. Plaintiff was not in that class.

Thus, while new installations made during the three-year interval between July 1, 1973, the effective date of the new General Business Law provisions, and July, 1976, when plaintiff was injured, could have counted *507 numerically in the totality of any statistics to support the existence of a developing

custom to use safety glass, defendants' objection to the statutes themselves should have been sustained. Without belaboring the point, it cannot be said that the statutes, once injected into the adversarial conflict, did not prejudice the defendants. Nor is it any answer to suggest that balancing the risk of prejudice against the asserted relevancy of the statutes here was a supportable discretionary judicial act. Unlike hearsay, which at times may be rendered admissible by necessity, the other proof of custom here eliminates the possibility of this justification.

For all these reasons, the order should be reversed and a new trial granted. In so ruling, we see no reason for a retrial of the damages issue. Instead, the new trial will be confined initially to the issue of liability and, if plaintiff once again should succeed in proving that defendants were negligent, to the issue of apportionment of fault between the parties (cf. *Ferrer v. Harris*, 55 N.Y.2d 285).

Accordingly, the case should be remitted to Supreme Court, Bronx County, for further proceedings in accordance with this opinion.

Order reversed, with costs, and case remitted to Supreme Court, Bronx County, for a new trial in accordance with the opinion herein.

Note 1. How does the court treat the evidence of industry custom, as well as the prescriptions by the legislature for the use of improved safety measures regarding glass in dwellings? What is the relevance of this extrinsic evidence to the plaintiff's case?

Note 2. Why is the plaintiff's conduct with respect to use of the shower raised?

Note 3. The court lists several rationales for the admission of custom evidence. What are they?

Note 4. Custom evidence as a "sword." *Trimarco* clarifies that use of custom evidence is not conclusive ("common practice or usage is still not necessarily a conclusive or even a compelling test of negligence... Before it can be, the jury must be satisfied with its reasonableness.") What effect does custom evidence have, in that case? Why is its use potentially powerful for the plaintiff?

Consider that case law continues, as *Trimarco* did, to cite this long-approved dicta: "What usually is done may be evidence of what ought to be done." *Texas & P.R. Co. v. Behymer*, 189 U.S. 468, 470 (1903). *Beving v. Union Pac. R.R. Co.*, 2020 WL 6051598, at *4 (S.D. Iowa Sept. 8, 2020).

Note 5. Custom evidence as a "shield." In *Trimarco* the court seems to suggest that compliance with custom could provide a defense: "when proof of an accepted practice is accompanied by evidence that the defendant conformed to it, this may establish due care (*Bennett v. Long Is. R. R. Co.*, 163 N.Y. 1, 4, 57 N.E. 79 [custom not to lock switch on temporary railroad siding during construction]). Despite *Trimarco's* dicta regarding compliance with custom, such compliance is rarely successfully used as a shield against liability. Merely showing that you didn't adopt a precaution, but *neither did anybody else in your industry* does not make that conduct reasonable. That was the scenario in the next case (excerpted).

Note 6. The T.J. Hooper, Second Circuit Court of Appeals (1932)

If evidence of customary practices can be used to establish breach, what happens if an industry is rapidly emerging (and norms aren't yet settled, or behavior is unusually risky)? What about if the industry is one that evolves frequently and norms are hard to catalog? What if social changes to conduct or business practices end up meaning that an entire industry has failed to take the proper precautions?

Judge Learned Hand, an extremely important jurist on the Second Circuit, faced a dispute over losses of coal that plaintiff's barges sustained when the defendant's tug boats, towing the barges, were lost in a storm off the Jersey Coast. Had the tugboats been equipped with radios, the crew could have received a widely publicized warning from the Weather Bureau and made for a safe haven in the Delaware Breakwater. Defendant pointed to industry custom to argue that barge lines didn't provide radio receiving sets to crews. Learned Hand upheld the lower court's verdict against the defendants, writing: "[I]n most cases reasonable prudence is in fact common prudence; but strictly it is never its measure; a whole calling may have unduly lagged in the adoption of new and available devices. It never may set its own tests, however persuasive be its usages. Courts must in the end say what is required; there are precautions so imperative that even their universal disregard will not excuse their omission."

The T.J. Hooper, 60 F.2d 737 (2d Cir. 1932).

Can you think of areas of evolving technology, or changing practices around privacy and data collection, that would illustrate the need for a rule like this one? Professor Jennifer E. Rothman considers the issue in *The Questionable Use of Custom in Intellectual Property*, 93 Va. L. Rev. 1899 (2013): "Defenses to uses of others' IP are generally rejected when deemed, either explicitly or implicitly, "unreasonable," and courts frequently defer to customary practices to determine whether a use is reasonable. [fn] It is not easy to define what constitutes a reasonable use of another's IP. A reasonable use is not the same as a just or moral use; instead, like the reasonable person standard in tort law, it asks more generally what is appropriate in a given circumstance, not what is optimal or ethical. Because it is difficult to determine when a use of another's IP is reasonable and there is little available guidance, courts often use custom as a shortcut or proxy for such determinations." Rothman worries that courts may entrench suboptimal behaviors simply because the behaviors are customary (no matter whether they are reasonable) and consequently fail to consider "reasonable" newer practices simply because those are not yet customary. How should rapidly evolving areas of law proceed with respect to custom evidence?

Circumstantial Evidence

A Primer on Burdens of Proof: Eventually, law students learn about the burden of proof in classes such as civil procedure and criminal law. However, in most law schools, students encounter issues pertaining to the burden of proof in tort law before they have gotten much past questions of jurisdiction in civil procedure. These issues are important to tort law yet are often assumed rather than explained in the cases assigned. This brief explanation is thus meant as a stopgap to assist your understanding in torts. The burden of proof is the party's obligation to prove their case, but it applies to each claim or defense relevant to winning the case overall.

First, the **burden of proof differs in criminal and civil cases**. You've certainly heard the burden of proof in criminal cases since it's so often evoked in legal dramas as well as in news accounts of significant criminal trials: the state must prove defendants' guilt **beyond a reasonable doubt**. Lawyers tend to think of this as requiring something like a 90-95% likelihood of certainty. Note that in criminal cases, the prosecutor is proving guilt. In civil cases, it is appropriate to use "liability" instead. Although older cases still sometimes state that a party is "guilty of negligence," be attentive to the confusion it could create to use the terms guilt and liability interchangeably and stick with liable instead. In most

cases, civil claims must be proven by a **preponderance of the evidence**, which is more like 51%. The standard requires that the account be *more likely than not* to have happened in the way the moving party claims. There is a third standard somewhere in between, known as the **clear and convincing standard**. Legislators and courts can use this in instances in which they wish to ratchet up the difficulty of proving something, to signal some sort of protection or a policy emphasis in the law.

Second, the burden of proof includes different aspects: the burdens of **production** and **persuasion**.

Both parties carry the burden of persuasion and it never “shifts” between them; if the party cannot persuade the judge or factfinder to accept their account as the likelier one, they will lose. The burden of production consists of the party’s obligation to present sufficient evidence on a claim that they can win on that issue. Quite often the plaintiff will win on this issue if the opposing party does nothing to rebut or defeat that evidence. It is sometimes called the “burden of going forward.” This begins with the pleadings: the plaintiff introduces all her evidence and the judge must decide whether the plaintiff has offered enough evidence that the jury *could* conclude that the defendant was negligent. If the plaintiff can do this, she has made out a **prima facie** case, that is a case in which the jury does not *have to* side with the plaintiff, but could do so. Then the defendant responds with an answer attempting to produce enough evidence that the jury *could* not conclude in the plaintiff’s favor.

The burden of production may shift between the parties. Think of it like a tennis game in which a ball (the burden) may travel back and forth between the parties or be caught in the net, thus ending the play on a given issue (and possibly the entire case). For example, if a party, X, bears the burden of proving that another party, Y was negligent in their conduct and caused X’s injuries, X will lose the entire case if X cannot bear the burden of production on the existence of a duty running from Y to X. Perhaps X can plead a duty and Y cannot rebut it. As the moving party, X must next prove breach, causation and damages. On the questions of breach and causation, in particular, there may be many smaller factual questions in which gaps in the factual record require filling. The plaintiff’s case might fail if these gaps mean she cannot establish what the defendant did to cause her harm. In the materials that follow, you will learn several **burden-shifting** devices that assist in shifting the burden from one party to another so that the case will not fail too early. Sometimes the burden shifts, for instance, from the plaintiff, who must ordinarily prove breach by the defendant. If so, this burden-shifting will cause the defendant to have to *disprove* breach. Burden-shifting devices are one of the ways in which parties can prove or defend against negligence claims given the complexity and factual gaps that arise with frequency in the fact patterns in torts cases.

Using circumstantial evidence is not formally a burden-shifting device, but it is one of the mechanisms by which the law may slightly relax the burden of production in cases where direct or real evidence is unavailable. A party may satisfy their burden of production on an issue only to have the opposing party successfully rebut it, of course, but the theory holds that it is fairer to force this exchange than it would be to prematurely end a claim merely because the plaintiff lacked particular kinds of evidence at the outset.

In a subset of torts cases—particularly cases of injury caused by falling on a slippery or poorly maintained floor—plaintiffs may be unable to prove the source of their injury or to identify how the defendant breached their duty of due care. In traditional cases, a plaintiff may prove their case using “real evidence” such as physical objects, forensic data and documentary evidence including video recordings or employee logs. Or they may offer proof in the form of “direct evidence” such as

eyewitness testimony or deposition of the defendant and related parties. Sometimes, however, these forms of evidence are unavailable or only partially so and the plaintiff must in some other way produce sufficient circumstantial evidence that the jury can draw inferences of the defendant's negligence. The outcomes in these cases hinge on the strength and sufficiency of the evidence. The next cases focus on slippery fruit (and other foods) that may cause injury.

Goddard v. Bos. & M.R. Co., Supreme Judicial Court of Massachusetts (1901) (179 Mass. 52) (Chief Justice Holmes)

The banana skin upon which the plaintiff stepped and which caused him to slip may have been dropped within a minute by one of the persons who was leaving the train. It is unnecessary to go further to decide the case.

Exceptions overruled.

Note 1. The plaintiff was injured in a “slip-and-fall” accident which is sometimes considered the “bread-and-butter” action of tort law, given the frequency with which such claims continue to be brought. Such actions are usually settled but sometimes involve significant injury or small but important points of law. They are also responsible for many safety measures taken by stores and other premises owners who fear liability and can pass the costs of precautions on to their consumers via raising the price of their goods, tickets or services. However, tort law does not seek to reduce risks to zero and premises owners are not the “insurers” of all who enter on their premises. How should courts determine the point at which liability for injury attaches? What sorts of inferences should be permitted when customers appear blameless but cannot explain the reasons for the accident that occurred? Banana peels are just the beginning.

Scaccia v. Bos. Elevated Rail Co., Supreme Judicial Court of Massachusetts (1944) (317 Mass. 245)

[***] When the plaintiff boarded the defendant's motor bus at Cleary Square in the Hyde Park section of Boston at noon on October 2, 1934, it could have been found that there was on the floor in the aisle, near the front of the bus, a banana *252 peel ‘four inches long, all black, all pressed down, dirty, covered with sand and gravel, dry and gritty looking.’ When the plaintiff left the bus nine minutes later, she slipped and fell on the banana peel, which remained in the same position. Only three passengers were in the bus during the trip. It could have been found that Cleary Square was one terminus of the line, and that the bus remained there without passengers in it for ‘a minute or two’ at least. The bus was operated by one man.

The question is whether the foregoing basic facts warrant an inference of negligence on the part of the defendant or its operator. No one would be likely to enter the bus except servants of the defendant and passengers. In the ordinary course of events, no passenger would carry into the bus a banana peel, or a banana, in the condition shown by the agreed facts. Such a condition naturally would result from lying

a considerable time on the floor. We think that it could be found that the peel had remained on the floor of the bus so long that in the exercise of due care the defendant should have discovered and removed it. [cc]

A number of cases in which the unexplained presence on floors or stairs of discarded parts of fruit was held insufficient evidence of negligence may be distinguished. In *Goddard v. Boston & M. R. R.*, 179 Mass. 52, the banana peel did not appear to be other than fresh. In *Mascary v. Boston Elevated R. Co.*, 258 Mass. 524 where a banana peel was much like that described in the Anjou case, it lay on stairs leading from the street, and might have been recently thrown there by a child in play. In *McBreen v. Collins*, 284 Mass. 253, and *Newell v. Wm. Filene's Sons Co.*, 296 Mass. 489, the plaintiff fell on a lemon or orange peel that showed no marks of age comparable to those in the present case. In other cases the cause of the injury was an apple core or other fruit which would become discolored sooner than a banana peel would become in the condition described in the evidence in the present case. [cc]

In accordance with the terms of the report, judgment is to be entered for the plaintiff as upon a finding for \$750.

So ordered.

Note 1. Why is the court discussing the condition of the banana (or lemon or orange) peel?

Note 2. What implicit theory does this observation address, when the court notes “no passenger would carry into the bus a banana peel, or a banana, in the condition shown by the agreed facts”?

Note 3. There is no evidence that a child actually *has* thrown the peel in this case. What purpose does it serve for the court, in dicta about an earlier precedent, *Mascary*, to add that the banana peel “might have been recently thrown there by a child in play”?

McDonald v. Safeway Stores, Inc., Supreme Court of Idaho (1985) (109 Idaho 305)

On April 17, 1981, at approximately 1:00 p.m., Alta McDonald entered a Twin Falls Safeway Store to make a purchase. As she walked down the aisle, her foot went out from under her and she fell, landing on her right hip. Safeway had been conducting an ice cream demonstration since 10:00 a.m. that day. The substance that Mrs. McDonald slipped on was cream colored and appeared to be melted ice cream. As a result of the fall, Mrs. McDonald suffered severe injuries, requiring the replacement of a total hip transplant which she had received shortly before the fall. Thereafter, Alta McDonald brought the action for damages for injuries she had sustained, her husband joining with a claim for loss of consortium, services, care, comfort and companionship. A jury trial resulted in a special verdict finding Safeway's negligence at 100% and awarding Alta McDonald damages of \$196,000 and Donald McDonald damages of \$35,000.

Safeway first assigns error to the trial court's denial of its motion for summary judgment, asserting that reasonable minds could not differ on the issue of whether the actions of the Safeway employees were reasonable under the circumstances. For reasons which follow we conclude that the trial court properly denied the motion.

The complaint alleged, in part:

That on or about Friday, April 17, 1981, at some time prior to plaintiff Alta McDonald's arrival at said store defendant negligently caused and/or permitted a slippery substance consisting of melted ice cream to be deposited and to remain *307 on the floor of said store in a place allowed for the passage of plaintiff and other customers and shoppers.

That defendant knew or reasonably should have known that slippery substances, including ice cream, would foreseeably be dropped by passing shoppers and would accumulate on the floor and would endanger the safety of persons walking on the floor. The melted ice cream had been dispensed negligently by the defendant and had been negligently allowed to remain on the floor for such a period of time immediately preceding the accident that persons of ordinary prudence in the position of defendant knew or reasonably should have known of the same, and in the exercise of ordinary care would have remedied the same, prior to the happening of the accident herein alleged. In spite of defendant's notice of the presence of the melted ice cream on the floor, defendant negligently failed and omitted to remove the slippery substance within a reasonable time and failed to take any precaution to prevent injury to plaintiff and other invitees that foreseeably would be injured. The accident and injury hereinafter alleged were proximately caused by the negligence of defendant in causing the ice cream to be dispensed in a manner in which it was foreseeable that it would cause injury to others, and in causing and permitting the melted ice cream to remain on said floor and in failing to take reasonable precautions to prevent injury to plaintiff or to warn of the dangerous, unfit or unsafe conditions.

In its memorandum opinion denying Safeway's motion for summary judgment, the trial court stated:

In most supermarket slip and fall cases the plaintiff merely slips on an item or slick spot, the presence of which cannot be explained by anyone. Normally, the hazard exists during the normal business operation of the supermarket. Naturally, in those cases, the focus of attention is on the knowledge, actual or constructive, of the market that the hazard involved was on the floor.

Here we have a substantially different situation. Three separate demos were being conducted on the premises of Safeway where food and napkins were being handed out to customers, including infants. This, giving plaintiff the benefit of all inferences, could have created an unreasonable risk of harm to people, even if the store had very efficient clean-up procedures. The mode of operation of the ice cream demo on a very busy Good Friday, combined with the abnormally large crowds and other demos, in and of itself could constitute an act of negligence on the part of defendant. It is also possible that Safeway should have taken super extraordinary supervisory precautions considering the mixture of ice cream and infants.

A jury question is presented regarding Safeway's negligence.

Safeway argues that the McDonalds' claim of negligence was based on two distinct theories, the first being that the Safeway employees had actual or constructive knowledge of the dangerous condition

and failed to remedy it and the second being that by permitting three separate demonstrations on a busy sales day and furnishing ice cream to infants, Safeway created a foreseeable risk of harm to its customers. Safeway contends that it was entitled to an order of summary judgment on the negligence claim regardless of the theory upon which the McDonalds relied.

[***] Clearly, as to the first theory of negligence, the record before the trial court permitted the reasonable inference that Safeway knew or should have known of the dangerous condition, that it had sufficient time to remedy the situation and that in the exercise of *308 reasonable care, its employees should have cleaned the spill.

Safeway contends that Idaho law does not permit a plaintiff to recover under the second negligence theory, that is, negligent creation of a foreseeable risk of harm. That theory does not require that the owner or possessor of land have actual or constructive knowledge of the dangerous condition. Safeway insists that in dispensing with the knowledge requirement, the second theory is inconsistent with Idaho law regarding the liability of an owner or possessor of land for injuries to an invitee. In support of this proposition Safeway cites *Tommerup v. Albertsom's, Inc.*, 101 Idaho 1 (1980) wherein we stated:

The law is well settled in this state that to hold an owner or possessor of land liable for injuries to an invitee caused by a dangerous condition existing on the land, it must be shown that the owner or occupier knew, or by the existence of reasonable care, should have known of the existence of the dangerous condition.

In *Tommerup*, the plaintiff-appellant Mrs. Tommerup, had slipped and fallen on a cupcake wrapper which apparently had been discarded in the parking lot near the doorway of a grocery store. The record was devoid of evidence indicating that the condition which caused Mrs. Tommerup's injury was anything other than an isolated incident. In *Tommerup*, we distinguished the "isolated incident" situation from circumstances where an alleged tortfeasor is charged with having actively created a foreseeable risk of danger in its course of business [***]. Certainly, the trial court could not have concluded *as a matter of law* that the presence of the ice cream on the floor was merely an isolated incident. Hence, it did not err in denying Safeway's motion for summary judgment.

Safeway next complains that the trial court erroneously permitted the McDonalds to introduce certain opinion testimony *309 and expert testimony at trial. Safeway contends that the McDonalds' counsel improperly elicited "expert testimony" from James Anderson, the Safeway's store manager. This "expert testimony" consists of the following exchange:

COUNSEL: Wouldn't you agree with me, Mr. Anderson, that two hours is more than ample time to insure cleaning up a spill like an ice cream spill and preventing an accident like this?

MR. ANDERSON: Yes.

The question and answer were not objected to at trial and the objection cannot be raised for the first time on appeal. [c] [***] The question posed by McDonalds' counsel properly elicited testimony tending to rebut Anderson's general line of testimony that the store had exercised due care.

[***] Safeway next maintains that the trial court erred in allowing McDonalds' counsel to conduct an "experiment" during closing argument. At the opening of closing argument, McDonalds' counsel unveiled a carton of Lucerne ice cream and placed a spoonful on a paper plate next to a thermometer

and left it on counsel table in full view of the jury during his argument. When Safeway's counsel inquired as to what the McDonalds' counsel was doing, the McDonalds' counsel stated, "I'm conducting an experiment. I'm not sure what the results are going to be, but I think it's proper argument." Safeway's counsel objected. The trial court overruled the objection, concluding that the "experiment" was an allowable, demonstrative argument. *310 Safeway submits that the "experiment" was not supported by the evidence, and that the use of the ice cream during closing argument should not have been allowed unless it was supported by evidence already admitted. Moreover, Safeway contends that the trial court should have, at a minimum, cautioned the jury that the "experiment" was not evidence and should not be given any consideration in reaching its decision. Clearly, the "experiment" was not proper evidence; however, that fact may not have been apparent to the jury. It is generally stated in 75 Am.Jur. *Trials* § 197 (1974) that:

It appears to be entirely legitimate for counsel in addressing a jury to use, by way of illustration or elucidation, diagrams and maps or other visual aids not put in evidence, provided that the jury understands that they are employed merely for such purposes and are not evidence in any sense. However, the use of charts or diagrams by counsel has been held not permissible in the absence of adequate foundation in the form of material actually introduced into evidence.

In *Meissner v. Smith*, 94 Idaho 563, 494 P.2d 567 (1972), we approved the use of charts in closing argument so long as the record did not reflect any unfair, misleading or inflammatory tactics by counsel in the use of the chart. Research has revealed no case on point and counsel for both parties were unable to provide authority for their respective positions on this matter. Nonetheless, we conclude that the "experiment" should not have been allowed, in that experiments are admissible as evidence only during the evidentiary phase of the trial, when the opposing party has the opportunity for objection to foundation, cross-examination, and rebuttal. We strongly admonish counsel against such antics and would order a declaration of mis-trial but for the fact that a complete review of the record reflects that the effect and purpose of the experiment was only to establish that even a small chunk of ice cream requires an hour or two to fully melt at room temperature. Since two witnesses had testified to that phenomenon and since Safeway did not dispute it, the error was harmless and cannot be said to have changed the result of the trial. Appellants have the burden to show prejudicial error and this they have failed to do. [c] Because we conclude that the result would have been the same had this "experiment" not taken place, we do not deem the error to be cause for reversal. [c] [***]

In support of its motion for a new trial, Safeway alleged the following specific errors:

- (1) The ice cream experiment was improper;
- (2) The jury verdict was excessive and unreasonable; *311
- (3) The verdict was contrary to the evidence; [***]

[The] asserted grounds in support of the new trial motion have been previously addressed in this opinion. We therefore affirm the judgment. Costs to respondents. No attorney fees.

Note 1. In your own words, how would you define "actual knowledge" versus "constructive knowledge"?

Note 2. What is the practical difference between the two theories of negligence: (1) failing to remedy a dangerous condition of which Safeway had actual or constructive knowledge versus (2) creating a

foreseeable risk of harm by permitting three separate demonstrations on a busy sales day and furnishing ice cream to infants? Why does it matter to distinguish the theories?

Note 3. Without employee testimony, how do you think a court should determine whether there was “sufficient time” to remedy a dangerous situation? Is time the right proxy for constructive notice? What others can you imagine working well?

Note 4. If tort law forced stores to internalize the costs of all possible accidents on its premises, it would effectively convert such entities into “insurers” of the safety of customers and other entrants on its premises. This could **overdeter the store’s managers** and **misalign the incentives for consumers** to take their own proper precautions. A rational response to increasing the scope of storeowner liability is to take increased precautions and pass the costs of those on to the consumer. Consider the following case in which the store was not held liable for a customer’s slip and fall on a slippery floor, the source of whose wetness the plaintiff could not adequately prove. The court describes an employee’s testimony, in which “she estimated that 98 percent of her time was spent walking the floors of the store looking for hazards. She also testified that any employee who sees a hazardous condition on the floor is responsible for either cleaning it up or getting someone else to do so.” Another employee corroborated that and further testified:

“Q [ATTORNEY FOR APPELLANT]: Now, in terms of whether things were on the floor, were you required or were you supposed to patrol around the store and look for anything that could probably [sic] be on the floor?

A: Well, we were always walking around the store, pretty much at all times except when we were on break. So you don’t have an assigned route, but yes, we were always walking around the floor.

Q: And then if you noticed something on the floor, you were supposed to take care of it right away?

A: Yes.”

Maans v. Giant Of Maryland, L.L.C., 161 Md. App. 620, 631 (2005)

Does this strike you as the optimal level of precaution in practice? Might some precautionary practices develop in order to defeat legal claims rather than out of a conviction that they will optimize for safety and employee efficiency?

Note 5. Dangerous Methods of Operation. Are you persuaded by the distinction of “isolated incidents” versus “continuous or recurring” conditions? In nearly two dozen jurisdictions, some version of a “recurring condition” rule has arisen to cover situations in which a business regularly confronts hazards associated with its “mode of operation.” *Kelly v. Stop & Shop, Inc.*, 281 Conn. 768, 783 (2007)(noting that there is a “distinct modern trend favoring the rule, and it appears that most courts that have considered the rule have adopted it”; *Kelly* reversed judgment for the defendant on the grounds that plaintiff should be allowed to adopt the mode of operation theory of negligence after she slipped on a “wet and slimy” piece of lettuce and found herself on the floor next to the cottage cheese and other fruit she’d been serving herself from the salad bar. While she lay there, an employee appeared at her feet to sweep up the cottage cheese and fruit. *Id.* at 253). This doctrine has often been justified by the growing number of self-serve restaurants or food service points in supermarkets.

For example, in *Jasko v. F. W. Woolworth Co.*, 177 Colo. 418 (1972), an early and influential case, the plaintiff slipped and fell on a slice of pizza that had wound up on the terrazzo floor of the defendant's store. The shop sold slices of pizza on waxed paper sheets to 500-1,000 buyers every day and there were no chairs or tables by the pizza counter. Hence most consumers stood in the shop while they ate. The court record showed that so many slices were dropped daily that porters were continually sweeping it up. The appellate court affirmed the trial court's dismissal on the grounds that the defendants lacked actual or constructive knowledge of the dangerous condition. The Supreme Court of Colorado reversed, reasoning that "when the operating methods of a proprietor are such that dangerous conditions are continuous or easily foreseeable, the logical basis for the notice requirement dissolves. Then, actual or constructive notice of the specific condition need not be proved." Although the Colorado state legislature enacted legislation to preempt common law duties of landowners, the case continues to be cited with approval for this doctrine. The dangerous mode of operation doctrine is sometimes criticized for being a form of strict liability; can you see why?

The next hypothetical applies the doctrine outside the context of food service to provide students with practice synthesizing the rules for duty and breach and applying them to new facts.

Expand On Your Understanding – Slip-and-Fall Synthesis Exercise

Irina Shea was injured when she slipped and fell on ice near the exit of the Lett's Downtown Car Wash in Coeur d'Alene, Idaho. She fell when she exited her vehicle to adjust her mirrors, which had been moved during the car wash. Shea alleged that Lett's owner, Kevic Corporation, was negligent in allowing ice to build up near the car wash exit or in failing to warn of the danger of ice buildup. Kevic did not use any warning signs, barriers, sanding or melting devices to warn or protect business patrons from the hazardous conditions.

Shea testified in her deposition:

Q. And when you were walking—when you got out of your car, when you first put your feet on the ground as you got out of the driver's seat, do you recall whether the ground was wet?

A. It was not wet.

Q. Was it dry?

A. It was dry. Everything was just amazingly dry just like right now.

Q. Okay, and when you walked around by the headlight—

A. Yeah. When I was just making around first move, and apparently there was water trickling down from underneath my car—from my car wash.

Q. Was it water or was it ice or what was it?

A. I don't know because when—I fell right away, and apparently it was slippery, so it was maybe water and ice all together

Shea also testified that, as she was “getting out of the car and putting the tip money and as [she] started to walk around,” she did not see any snow or ice on the ground. Shea explained, “There was just nice weather, and everything was so dry. Nothing would suggest that it could be that.” Shea stated that she did not see what she slipped on. She also stated that she did not notice any ice around her car before or after she fell. After her fall, she explained, “It was so dry and nice.”

Lett’s manager is John Lett. In Lett’s deposition, he testified that every car that comes out of the car wash “is dripping a little water” and he agreed that “when it’s cold ... the water that vehicles ... track from the car wash ... freezes.” Lett also testified that “[t]he employees are instructed to spread de-icer on the icy areas as needed.” Lett discussed his actions and observations immediately following Shea’s accident. Lett was working at the car wash the day of the accident, and he explained that an individual notified him that someone had fallen and broken their wrist in the car wash parking lot. Lett went over to the car wash exit and assisted the injured person, Shea, in getting out of the vehicle and obtaining medical treatment. During this discussion of the events following Shea’s accident, Lett was asked, “And at the exit of the car wash that day what were the conditions like?” He responded, “It was cold and icy.”

The temperature on the day of her alleged accident ranged from 28.9 degrees Fahrenheit to 38.9 degrees Fahrenheit.

Shea sought over \$30,000 in damages. Kevic concedes that Shea had the status of an invitee on the car wash premises and Idaho follows the status-based rule for duties of possessors of land.

First: Practice stating the rule for duty under these circumstances.

An interactive H5P element has been excluded from this version of the text. You can view it online here: <https://saidtorts2d.lawbooks.cali.org/?p=59#h5p-79>

Second: Practice breach analysis using circumstantial evidence.

An interactive H5P element has been excluded from this version of the text. You can view it online here: <https://saidtorts2d.lawbooks.cali.org/?p=59#h5p-80>

Third: Skipping causation, which you have not yet learned, what conclusion would you draw regarding Kevic’s liability?

An interactive H5P element has been excluded from this version of the text. You can view it online here: <https://saidtorts2d.lawbooks.cali.org/?p=59#h5p-81>

Chapter 18. Negligence Per Se and Res Ipsa Loquitur

Statutory Violations as Negligence Per Se Restatement (3d) on Torts § 14 (2010)

An actor is negligent if, without excuse, the actor violates a statute that is designed to protect against the type of accident the actor's conduct causes, and if the accident victim is within the class of persons the statute is designed to protect.

Definition. Negligence per se is a doctrine with an evidentiary and a substantive effect that pertains to **one party's use of the other party's alleged violation of a statute to prove the defendant's breach** of their duty of care. The rationale behind the doctrine is that in some cases the legislature may be deemed to have specified the appropriate standard of care and this may be "borrowed" for the factfinders assessing the standard of care in a given case. Negligence per se applies to statutes but it is usually also extended to municipal ordinances and administrative regulations, so the term "the law" in part (2) of the formulation below should be construed broadly.

Because negligence per se could be considered as removing the question of breach from the jury's determination—substituting the legislature's judgment for the jury's, effectively—the doctrine requires careful determinations of whether it will apply at all and, if it does apply, what effect it will have on the jury's decision making.

Before the doctrine can be applied (usually by the jury), the judge determines the applicability of the alleged violation, with a two-pronged inquiry. **First**, the violation must be proven by the plaintiff. This is not necessarily the difficult part of the test. There may be visual evidence available from a speed camera or closed-circuit video; documentary evidence that someone furnished a minor with liquor; or other modes of easily proving the statute's violation, in addition to more expensive means of proof including calling eyewitnesses. Still, the plaintiff cannot take this step for granted. **Second**, the statute's applicability for purposes of determining breach requires a four-part test. Only if all four requirements ((2)a-d, below) are met will negligence per se apply. Concretely, then, this means that negligence per se may be applied:

- (1) **when a civil statute or ordinance is violated, and**
- (2) when the law that has been violated is designed to
 - (a) **protect a class of persons which includes the person** whose interest is invaded,
 - (b) **protect the particular interest** which is invaded,
 - (c) **protect against the kind of harm** which resulted, *and*
 - (d) **protect that interest against the particular hazard** from which the harm results.

Exam tip: When facing a negligence per se scenario, be sure to methodically check off each of these requirements! On a test, it may be just a few points lost for failure to do so. In court, the entire case might live or die based on one of these elements.

**McCarthy v. Weathervane Seafoods, U.S. District Court, D. New Hampshire
(2011)
(2011 WL 2174036)**

*1 Kevin McCarthy brings claims of negligence and negligence per se against Weathervane Seafoods, arising from injuries he sustained when he fell from a ladder while attempting to climb to the roof of a Weathervane restaurant to repair a leak. Weathervane moves for summary judgment, contending that the negligence claim fails because Weathervane owed no duty to McCarthy and the negligence per se claim fails due to a lack of a statutory basis for the claim. McCarthy objects to the motion.

Weathervane Seafoods operates several restaurants in New Hampshire, including a restaurant located at 174 Daniel Webster Highway in Nashua. During the events at issue in this case, McCarthy was self-employed as a heating, ventilation, air conditioning, and refrigeration technician doing business as Maxair.⁹⁸ McCarthy was approved to provide service to the HVAC units at Weathervane restaurants, including the Nashua restaurant, and had provided service on several occasions before the accident that is the basis for this case.

On June 13, 2010, Jennifer Burgess, Assistant Manager at the Nashua Weathervane restaurant, asked McCarthy to inspect and repair a leak in the roof of the restaurant. McCarthy inspected the leak from the kitchen area and then decided he would have to go up on the roof. McCarthy had been told previously that there was a ladder chained to a pipe behind the restaurant, which was used to access the roof. McCarthy found the ladder, unchained it, and extended it up the side of the restaurant. Burgess watched McCarthy set and climb the ladder. As McCarthy got near the top of the ladder, the bottom slipped out, and he fell. McCarthy was badly injured in the fall. [***]

Weathervane moves for summary judgment on the grounds that McCarthy cannot prove his negligence claim because Weathervane did not owe him a duty to protect against an open and obvious danger and because Weathervane did not know nor should it have known of the slippery condition where the ladder was located. Weathervane also contends that McCarthy failed to state a negligence per se claim. McCarthy objects, arguing that Weathervane breached its duty of reasonable care and duty to warn and that his negligence per se claim is based, properly, on Occupational Safety and Health Administration (“OSHA”) regulations and New Hampshire regulations.

A. Negligence

*2 “To recover for negligence, a plaintiff must demonstrate that the defendant had a duty, that he breached that duty, and that the breach proximately caused injury to the plaintiff.” [c] “Whether a duty exists in a particular case is a question of law.” [c] [***] In his negligence count, McCarthy alleges that Weathervane “failed to provide a safe and secure restaurant, ladder, rear exterior of the restaurant or roof of the restaurant.” More specifically, McCarthy alleges that Weathervane “allowed a hazardous condition to exist in the area where the ladder had been placed causing the ladder to slide out from under Mr. McCarthy.” Weathervane challenges the claim to the extent that McCarthy alleges negligence because the ladder with which he was provided was too short. In response, McCarthy

⁹⁸ Heating, ventilation, and air conditioning is commonly abbreviated as “HVAC.”

defends his negligence claim on the ground that Weathervane was negligent because the area where the ladder was placed was slippery due to grease build-up.

1. *Ladder*

McCarthy alleges, in part, that Weathervane failed to provide a safe and secure ladder because the ladder was too short to provide safe access to the roof. Weathervane contends, in support of summary judgment, that even if the ladder it provided was too short, that defect was open and obvious. A landowner does not have a duty to warn or instruct of a dangerous condition on the premises if it is open and obvious. [c]

In objecting to summary judgment, McCarthy does not respond to Weathervane's argument that the alleged defect in the ladder was open and obvious. Instead, McCarthy focuses on the slippery condition of the area where the ladder was located. Because McCarthy does not pursue a claim that Weathervane was negligent for providing a ladder that was too short, Weathervane is entitled to summary judgment on that part of the negligence claim.

2. *Condition of the Back Dock Area*

"A premises owner owes a duty to entrants to use ordinary care to keep the premises in a reasonably safe condition, to warn entrants of dangerous conditions and to take reasonable precautions to protect them against foreseeable dangers arising out of the arrangements or use of the premises." [c] "[A] premises owner is subject to liability for harm caused to entrants on the premises if the harm results either from: (1) the owner's failure to carry out his activities with reasonable care; or (2) the owner's failure to remedy or give warning of a dangerous condition of which he knows or in the exercise of reasonable care should know." [c]

*3 [***] [Employees testified that] during the frying operations at the restaurant, the cooks skim debris out of the frying oil and put it into an empty cardboard box. When necessary, one of the cooks takes the box out to the dumpster behind the restaurant. The grease in the boxes drips onto the pavement behind the restaurant, known as the back dock area, on the way to the dumpster. The restaurant managers discussed the problem of grease buildup in the back dock area, and the grease problem had to be addressed daily. [***] [C]ompany policy required the back dock area to be kept clean from grease and oil and not to be slippery. [***] [G]rease from the fryers was permanently on the pavement in the back dock area. [***] [A]nother employee testified that they had used a power washer with degreaser to clean the back dock area until the power washer broke, two months before McCarthy's accident. Weathervane did not replace the power washer, so the employees used a less powerful hose without degreaser to try to clean the area.

The Weathervane regional manager testified that he checked the back dock area at the Nashua restaurant regularly. He said that he was checking for cleanliness, trash, and to be sure that it was grease-free. He stated that grease in the back dock area was a safety concern. The regional manager testified that when grease built up in the area, the employees were supposed to clean it or, if necessary, hire someone who could clean it. He also testified that he had reviewed comments in forms from the Nashua Weathervane about grease buildup in the back dock area.

After the fall, McCarthy was treated by EMTs from the Rockingham Regional Ambulance service. One EMT who was kneeling next to McCarthy to provide treatment noticed when he stood up that the

knees of his pants and tips of his shoes were coated with a significant amount of grease. He said that the grease smelled like fish and required several washings to remove.

McCarthy's evidence of grease on the pavement in the back dock area where he attempted to use the ladder to access the roof demonstrates at least a disputed issue of fact as to whether Weathervane knew or should have known that the grease that accumulated there was a safety issue. Although Weathervane states that McCarthy inspected the area where he put the ladder, the evidence cited in support of that statement was not provided in the record. In contrast, McCarthy provided his interrogatory answer in which he stated that after falling he noticed the pavement was covered with grease and that he could not have seen the grease before climbing the ladder because it was lightly raining which caused all of the pavement to appear to be wet.

***4** Therefore, Weathervane has not shown that it is entitled to summary judgment on McCarthy's negligence claim based on the slippery condition of the back dock area.

B. *Negligence Per Se*

In Count II of his complaint, McCarthy alleges negligence per se, stating that Weathervane "is responsible for operating the restaurant in compliance with Federal and State labor laws and regulations" and "[i]n particular, Weathervane Seafoods is responsible for complying with OSHA regulations and New Hampshire state laws pertaining to ladder safety." McCarthy further alleges that "the Weathervane Seafoods failed to comply with OSHA and New Hampshire state laws pertaining to ladder safety. *See e.g.* RSA 277:2." McCarthy continues by alleging that Weathervane allowed "an unsafe and non OSHA or New Hampshire compliant ladder to be used to access the roof of the restaurant."

Under the negligence per se doctrine, the standard of conduct is provided by statute. [c] The negligence per se doctrine applies if "the injured person is a member of the class intended by the legislature to be protected, and ... [if] the harm is of the kind which the statute was intended to prevent." *Id.* (internal quotation marks omitted). In addition, "[a]n implicit element of this test is whether the type of duty to which the statute speaks is similar to the type of duty on which the cause of action is based." *Id.* (internal quotation marks omitted).

Weathervane contends that McCarthy's negligence per se claim fails because the New Hampshire statute cited, Revised Statutes Annotated ("RSA") § 277:2, is inapposite to the circumstances in this case, because OSHA regulations cannot provide the basis for a negligence per se claim, and because McCarthy cannot add new grounds for the claim in response to a motion for summary judgment. In response, McCarthy contends that he cited RSA 277:2 only as an example of a statute pertaining to the ladder provided by Weathervane, cites New Hampshire Labor regulations as the basis for his claim, and argues that OSHA regulations can support a negligence per se claim. [***]

1. RSA 277:2.

RSA chapter 277 governs employment by "the state or any of its political subdivisions." RSA 277:1–b, II. RSA 277:2, which requires, among other things, that the state or a political subdivision acting as an employer provide proper protection to employees who are using a ladder to make repairs, does not apply to Weathervane, which is not the state or one of its political subdivisions. Therefore, to the extent

McCarthy's negligence per se claim is based on RSA 277:2, Weathervane is entitled to summary judgment.

2. State Regulations

*5 McCarthy argues in his objection to summary judgment that certain New Hampshire labor regulations pertaining to ladders are the basis for his negligence per se claim. McCarthy also argues that Weathervane was negligent per se because the buildup of grease in the back loading area violated certain sections of the International Building Code and International Property Maintenance Code, incorporated into New Hampshire law by RSA 155-A:2. Weathervane responds that McCarthy cannot identify new grounds for his claim for purposes of avoiding summary judgment.

[***] In this case, McCarthy alleges that Weathervane's failure to adhere to New Hampshire's laws pertaining to ladder safety constituted negligence per se. In his objection, McCarthy identifies New Hampshire Code of Administrative Rules, Labor 1403.30, and contends that the ladder provided by Weathervane was too short, in violation of the regulation. McCarthy also represents that he identified Labor 1403.30 as a basis for his negligence per se claim in discovery provided to Weathervane. Given McCarthy's pleadings and the disclosure of Labor 1403.30, specifically, in discovery, that part of McCarthy's negligence per se claim is not a new claim for purposes of summary judgment.

McCarthy also asserts in his objection that his negligence per se claim is based on the slippery condition of the back area where the ladder was located and contends that the slippery condition violated Section 116 of the International Building Code and Section 302.1 of the International Property Maintenance Code. McCarthy did not allege the slippery condition in his complaint as a basis for his negligence per se claim and did not reference the International Building Code or the International Property Maintenance Code. [***] *6 Because McCarthy did not allege the factual basis for negligence per se based on slippery conditions or either Code that he now cites, those grounds for his negligence per se claim were not part of his complaint. McCarthy cannot raise a new claim in his objection to summary judgment.

3. OSHA Violations

[***] The New Hampshire Supreme Court has not decided whether a violation of an OSHA regulation could support a state law claim for negligence per se. [***] [However T]he First Circuit has held that a state law negligence per se claim cannot be based on a violation of an OSHA regulation. Weathervane is entitled to summary judgment on McCarthy's negligence per se claim to the extent it is based on an OSHA violation.

Weathervane also argues that even if an OSHA violation could support a negligence per se claim, OSHA regulations apply to employers and therefore do not apply in the circumstances of this case where McCarthy was an independent contractor. [c] That issue need not be resolved in light of the First Circuit's holding in *Elliot* that OSHA violations cannot be the basis for state law negligence per se claims.

*7 For the foregoing reasons, the defendant's motion for summary judgment (document no. 10) is granted to the extent that the plaintiff's negligence claim is based on a theory that the ladder provided was too short and to the extent the negligence per se claim is based on RSA 277:2, violation of the

International Building Code or the International Property Maintenance Code due to a slippery condition, and OSHA regulations. The motion is otherwise denied.

The plaintiff's remaining claims are:

- (1) negligence based on the alleged slippery condition of the area where the ladder was located, and
- (2) negligence per se based on an alleged violation of New Hampshire Administrative Code, Labor 1403.30.

SO ORDERED.

Note 1. McCarthy's claim survives based only on the basis of the grease buildup even though the ladder *was* unlawfully short. Does it seem overly technical to insist on using negligence per se in this fashion, or does it seem consistent with the various hurdles and limitations created to guide its proper use?

Note 2. A few months later, a subsequent ruling for the defendant granted summary judgment on the negligence per se claim relating to Weathervane's alleged violation of New Hampshire Administrative Code Labor 1403.30. It ruled that this statute did not apply to independent contractors such as McCarthy providing services to private entities such as Weathervane, thus leaving only the common law premises liability negligence claim against Weathervane for its slippery conditions. *McCarthy v. Weathervane Seafoods*, No. 10-CV-395-JD, 2011 WL 4007406, at *1 (D.N.H. Sept. 8, 2011)

It matters (descriptively) what statute or regulation was violated, as *McCarthy* makes clear. If the work of determining breach of duty is to be taken from the jury and prescribed by statute, there ought to be normative justifications for that divestiture of jury authority, such as careful alignment with legislative purpose and scope. But should it be taken from the jury in the first place? Furthermore, does parsing the statutes in this way make determinations of negligence overly formalist and risk diminishing the substantive justice of the outcome? Put another way, should the statute that sets standards for government buildings not apply in this case involving a privately owned building simply because the statute's applicability is limited to government-owned buildings? And why should OSHA standards be rendered irrelevant just because a case involves an independent contractor rather than an employee — should the level or kind of conduct required in a negligence action vary depending on whether the injured person is an employee or a contractor?

Which of tort law's purposes are served by adhering to the technicalities associated with these rules? What incentives do such rules create?

Effect. Remember when analyzing negligence per se to pay close attention to the applicability and effect of any statutory violation and always remember to check whether the plaintiff can succeed by **reverting to common law negligence in the alternative**. Depending on the jurisdiction (and possibly the activity at issue), the effect of using a statute in this way can vary. In some instances, a plaintiff may use the proven violation of a statute simply as admissible evidence for the jury to consider as it evaluates whether the defendant breached their duty of care. This is known as an "evidence of negligence" regime. In other cases, a proven statutory violation can be treated as conclusive of negligence. If the plaintiff can prove that the defendant violated a statute, that evidence will also suffice to satisfy the plaintiff's burden on the element of breach, and the plaintiff will then need to be able to

prove that that statutory violation caused the harm of which plaintiff complains. Can you see the difference in these two possible effects?

Civic v. Signature Collision Centers, LLC, D.C. Court of Appeals (2019) (221 A.3d 528)

Appellant Melanne Civic sued appellees Signature Collision Centers, LLC and H.P. West End, LLC, alleging that their negligence was responsible for injuries she suffered in a fall. A jury found that Signature and H.P. West End had been negligent, but that Ms. Civic’s contributory negligence barred her from recovering. Ms. Civic argues on appeal primarily that the trial court erroneously declined to instruct the jury on the issue of per se negligence. We affirm.

I.

Except as indicated, the following facts appear to be undisputed. In February 2013, Ms. Civic fell on a “handicap ramp” while walking out of an automobile-repair shop operated by Signature and owned by H.P. West End. Ms. Civic testified that she fell because of an unmarked vertical and horizontal gap between a landing and the ramp. Ms. Civic introduced expert testimony that the vertical component of the gap was two to three inches and that the gap was inconsistent with the requirements of the District of Columbia Building Code. According to Ms. Civic’s expert, the gap was unsafe and contrary to applicable standards of care. The defense elicited testimony that Ms. Civic had previously gone in and out of the repair shop, that she did not recall whether she was using the handrail when she fell, and that she was carrying a boot and a cell phone when she fell.

Ms. Civic asked the trial court to instruct the jury that if the jury found that Signature and H.P. West End violated D.C. Building Code § 1003.6, then the jury was required to find that Signature and H.P. West End were negligent. At the time of the incident at issue, § 1003.6 required among other things that a path of egress consist of a “continuous unobstructed path of vertical and horizontal egress travel.”

The trial court declined to give the requested instruction. The trial court did, however, give an instruction that if the jury found that Signature and H.P. West End violated § 1003.6, the jury could consider that violation as evidence of negligence. Relatedly, the trial court instructed the jury, over Ms. Civic’s objection, that if the jury found that Ms. Civic’s negligence was a proximate cause of her injuries, the jury could not find Signature and H.P. West End liable.

II.

Ms. Civic’s principal challenge is to the jury instructions. Whether the jury *530 instructions were accurate is a question of law that we decide de novo. [c] We find no error.

“In the District of Columbia, a plaintiff in a negligence action generally cannot recover when [the plaintiff] is found contributorily negligent.” [c] That bar on recovery does not apply, however, if the plaintiff can show that the defendant’s conduct violated a statute or regulation intended to give “classes of persons likely to be careless ... greater protection than that which might be afforded at common law.” [c] We have often referred to the latter principle as the doctrine of “negligence per se.” [c] A

plaintiff may rely on that doctrine only if the plaintiff “is a member of the class to be protected by the statute.” [c]

To the extent that § 1003.6 is viewed as merely part of the general Building Code, we do not see any basis upon which to conclude that § 1003.6 was intended to provide a class of unusually vulnerable persons with heightened protections. [***] The trial court thus correctly declined to instruct the jury on per se negligence in the circumstances of this case.

We do wish to clarify two points. First, there is some indication that § 1003.6 may relate to fire-code provisions or might be understood as directed at providing protections for persons with disabilities. The current case does not involve a plaintiff with a disability or who was fleeing from or responding to a fire or other emergency, and we express no view about the applicability of the doctrine of per se negligence in such cases. Second, the broad language in [earlier] cases [c] should not be understood to categorically foreclose the possibility that a provision in a building or housing code could provide a predicate for an instruction as to per se negligence. To the contrary, this court has held that, in at least some circumstances, provisions of the Housing Code would provide a predicate for application of the principle of per se negligence. *See Scoggins v. Jude*, 419 A.2d 999, 1005-06 (D.C. 1980) (policy underlying Housing Code generally precludes landlord from relying on contributory negligence based on theory that tenants or guests should not have remained in premises or should have repaired premises themselves).

Ms. Civic’s arguments do not persuade us that the trial court in this case was required to give an instruction on per se negligence. First, Ms. Civic relies on the following language from our decision in *531 *Ceco Corp. v. Coleman*, 441 A.2d 940, 946 (D.C. 1982) (internal quotation marks omitted):

The general rule in this jurisdiction is that “where a particular statutory or regulatory standard is enacted to protect persons in the plaintiff’s position or to prevent the type of accident that occurred, and the plaintiff can establish [the plaintiff’s] relationship to the statute, unexplained violation of that standard renders the defendant negligent as a matter of law.”

Considered in isolation, that language would seem to make the doctrine of per se negligence applicable to all statutes or regulations that have a public-safety purpose. As we have already explained, however, *supra* at 530, the analysis in and holdings of our prior and subsequent cases make clear that the doctrine is not so sweeping, at least in the context of contributory negligence. Rather, we have found statutes or regulations to be a basis for lifting the contributory-negligence bar when those statutes or regulations were directed at “protect[ing] persons from their own negligence.” [c]

Second, Ms. Civic relies heavily on our decision in *Scoggins*, 419 A.2d 999. Specifically, Ms. Civic reads that decision as standing for the proposition that violations of the Housing Code are generally per se negligent, thus lifting the contributory-negligence bar, unless the plaintiff engaged in “unreasonable conduct which may have added to a dangerous condition.” *Id.* at 1006. [***]

[W]e do not share Ms. Civic’s interpretation of *Scoggins*. *Scoggins* held that, in general, “the Housing Regulations impose only a duty of reasonable care upon owners of rental property.” 419 A.2d at 1005. We thus further held that contributory negligence is generally a defense to a claim of negligence resting on a violation of the Housing Regulations. *Id.* (“[I]f there is sufficient evidence tending to show a tenant (or a tenant’s guest), by act or omission, unreasonably increased the exposure he or she

otherwise would have had to danger created by a landlord’s failure to comply with the Housing Regulations, the jury should be allowed to consider whether there was contributory negligence. No public policy would be frustrated.”) (citation omitted).

We identified an exception to the latter principle, however: landlords generally are not permitted to base a claim of contributory negligence on the conduct of a tenant or guest in simply using the premises or failing to themselves repair the premises, because such defense would “undermine the public policy implicit in the Housing Regulations.” *Id.* at 1004-05. Applying these principles, we held that the trial court properly declined to instruct the jury on the theory that the tenant and guest in the case were contributorily negligent by simply remaining in and moving about the apartment even though there was a crack in the apartment’s ceiling. *Id.* at 1005-06. Finally, we held that the jury ought to have been allowed to consider whether the tenant was contributorily negligent by hanging plants in the ceiling (or failing to remove the plants), which may have caused the apartment’s ceiling to collapse. *Id.* at 1006. On the last point, we explained that

In contrast with the policy permitting a tenant to remain in a substandard living room and to take reasonable steps to protect his or her property—for which there is no reasonable alternative—there is no public policy that would suggest *532 barring the landlord from alleging a tenant’s contributory negligence through unreasonable conduct which may have added to a dangerous condition. *Id.*

In sum, *Scoggins* is entirely consistent with our conclusion in this case that violations of the Building Code generally do not amount to per se negligence barring the defense of contributory negligence. [***]

Finally, Ms. Civic relies on a second provision – American National Standards Institute (ANSI) A117.1 –that apparently sets additional requirements for safe walkways. According to Ms. Civic, that provision was adopted as part of the District’s Building Code, and the trial court erroneously barred Ms. Civic’s expert from testifying to the jury about the provision. To the extent that Ms. Civic’s argument is directed at the idea that the jury was erroneously deprived of information that would have been relevant to whether Signature and H.P. West End were negligent, any error was harmless, because the jury in any event found that Signature and H.P. West End were negligent. *See, e.g., Knight v. Georgetown Univ.*, 725 A.2d 472, 479 n.7 (D.C. 1999) (error harmless where court could say with fair assurance that error did not substantially sway jury’s verdict). It is not clear whether Ms. Civic is also relying on ANSI A117.1 as a basis upon which the trial court ought to have instructed the jury about per se negligence. If so, ANSI A117.1 would not have provided such a basis in the circumstances of this case, for the reasons stated above with respect to § 1003.6 of the Building Code.

For the foregoing reasons, the judgment of the Superior Court is affirmed.

Note 1. What is the difference between what Civic sought in a jury instruction and what the trial court instructed? Why does it matter?

Note 2. Statutes and regulations are increasingly incorporating by reference the standards produced by standard-setting organizations, such as the American National Standards Institute (“ANSI”) mentioned in *Civic*. Some industry standards are considered as custom evidence even if not incorporated by reference (as seen in *Trimarco v. Klein*). These standards raise difficult questions for courts. For instance, should standards *not* incorporated be given the same weight as mere custom or more, given

the rigor of the standard-setting process? Should standards incorporated by reference be treated like statutes, even though the details are not worked through via a legislative or regulatory process? Courts have treated some privately generated standards with skepticism. See Bernard Bell, *Engineering Rules: Chronicling the Development of A Third Way*, Yale Notice & Comment (Oct. 2, 2019), at footnote 12 and accompanying text, reviewing Joanne Yates and Craig N. Murphy, *Engineering Rules: Global Standard Setting Since 1880* (John Hopkins University Press 2019) (quoting *Rossell v. Volkswagen*, 147 Ariz. 160, 166, 709 P.2d 517, 524 (1985), cert. denied, *Volkswagen of America v. Rossell*, 476 U.S. 1108 (1986))

Recent scholarship provides an intriguing account of the rise of standardization and its importance in an increasingly global market, especially given the safety, interoperability and performance issues that have driven its rise.

[T]he standardization movement was largely initiated by engineers who considered performing public service an avenue for enhancing engineering’s status as a profession. Indeed, one of the first major debates among standard-setters involved allowing business entities to formally participate in their standard-setting processes. Pragmatism was central to the decision; without business participation any standards produced were much less likely to attain widespread adoption. At various points over the course of time devotees of standardization saw their efforts as a means of enhancing the competitiveness of their countries’ industry vis-à-vis those of other countries, improving the conditions of laborers, enhancing economic growth, contributing to their nation’s war efforts when conflicts raged and encouraging peace and avoidance of war when such conflicts ended, enhancing the internationalist post-World-War-II vision, and facilitating the development of the Internet as a radical change in the way people interacted. Bell, *Engineering Rules*, *supra* at footnote 6 and accompanying text.

Given growing concerns over labor and supply chains as well as the environmental costs of manufacturing, the legal, regulatory and ethical questions involved in standardization will likely only continue to become more pressing. Despite the concerns that self-regulation can raise—the fox guarding the henhouse, and so on—there is value in private standard-setting organizations. For one thing, they are capable of being “far more nimble in adapting to technological change” and thus “regularly revise their standards in light of technological advances.” *Id.* at footnote 15 and accompanying text.

Note 3. In your study of defenses to negligence claims in Module 4, you will learn about defenses based on the plaintiff’s conduct. A handful of jurisdictions, including D.C., follow “contributory negligence,” which bars plaintiffs from recovery when they are at fault. (Module 1’s *Fox v. Glastenbury* also introduced the concept of contributory negligence.) Various doctrines limit what might otherwise be a fairly harsh rule for plaintiffs, including negligence per se in some instances. Contributory negligence imposes deliberate constraints on plaintiffs while negligence per se attempts to protect and facilitate recovery for plaintiffs under particular circumstances, which is why it can sometimes be used to mitigate the otherwise harsh result of contributory negligence. In attempting to balance these competing policy aims, does the court get it right in *Civic*, in your view?

Note 4. *Civic* distinguishes between statutes like the general building code (which protect the general public) and statutes aimed at providing “a class of unusually vulnerable persons with heightened protections.” When statutes exist to protect the vulnerable, such as small children or workers whose safety depends on others, their violation in many jurisdictions will be treated as dispositive (or “per se negligence”). For instance, in *Koenig v. Patrick Construction Corp.*, the plaintiff was a window cleaner hired by the defendant as an independent contractor. The defendant’s employees had instructed the plaintiff to use a 20-foot wooden ladder to reach the upper windows. The ladder lacked “safety shoes” to prevent slipping when the ladder was in use. It also lacked the necessary notches to which such safety shoes attached. These omissions were both violations of the local labor law. The ladder slipped, causing the plaintiff to fall and sustain serious injuries. A jury found for the defendant after being instructed that they must determine whether the plaintiff had properly used the ladder and evaluate the plaintiff’s fault, if any. On appeal, the Court of Appeal reversed:

[A] plaintiff’s carelessness is no bar to his recovery under a statute which imposes liability ‘regardless of negligence’. [c] Obviously, not every statute which commands or prohibits particular conduct is within this principle. Only when the statute is designed to protect a definite class of persons from a hazard of definable orbit, which they themselves are incapable of avoiding, is it deemed to create a statutory cause of action and to impose a liability unrelated to questions of negligence. This rule is based upon the view that, not being dependent upon proof of specific acts of negligence on defendant’s part, the cause of action may not be defeated by proof of plaintiff’s want of care. Thus, it has been said, ‘If the defendant’s negligence consists in the violation of a statute enacted to protect a class of persons from their inability to exercise self-protective care, a member of such class is not barred by his contributory negligence from recovery for bodily harm caused by the violation of such statute’. Restatement, Torts, s 483.

Since the plaintiff’s cause of action does not rest on negligence, contributory negligence does not constitute a defense. Indeed, the very purpose of the statute was to protect plaintiff’s intestate and others in like position from the consequences of their own negligence. It would be strange, therefore, if the same negligence could defeat the operation of the statute. [c]

The safe-ladder provision of section 240 comes squarely within this doctrine. By its force, certain safeguards have been legislatively commanded for the safety of those engaging in the work described. Instead of simply defining the general standard of care required and then providing that violation of that standard evidences negligence, the legislature imposed upon employers or those directing the particular work to be done, a flat and unvarying duty.

This the language of the section makes crystal clear: the employer or one directing the work ‘shall furnish’ or cause to be furnished equipment or devices ‘which shall be so constructed, placed and operated as to give proper protection’ to the one doing the work. [***] For breach of that duty, thus absolutely imposed, the wrongdoer is rendered liable without regard to his care or lack of it.

And, what the statute declares, its reason confirms. Workmen such as the present plaintiff, who ply their livelihoods on ladders and scaffolds, are scarcely in a position to protect themselves from accident. They usually have no choice but to work with the equipment at hand, though danger looms *319 large. The legislature recognized this and to guard against the known hazards of the occupation required the employer to safeguard the workers from injury caused by faulty or inadequate equipment. If the employer could avoid this duty by pointing to the concurrent negligence of the injured worker in using the equipment, the beneficial purpose of the statute might well be frustrated and nullified. That possibility we long ago perceived and provided for, declaring that ‘this statute is one for the protection of workmen from injury, and undoubtedly is to be construed as liberally as may be for the accomplishment of the purpose for which it was thus framed’. [c] Such an interpretation manifestly rules out contributory negligence as a defense to an action predicated upon violation of the statute to the injury of one in the protected class. [cc]

A different case would be before us if the injured person were a passerby or a workman struck by a falling ladder; as to them persons outside the class for whose special benefit the statute was designed a violation might do no more than evidence negligence. That, however, is not this case. Here, to recapitulate, we have an action based upon a statute whose cardinal purpose was to protect plaintiff and others in his calling, without reference to questions of negligence, from the occurrence of just such an accident as befell him. In spite of this, the trial court left the jury free to bring in a verdict against plaintiff if it found him guilty of contributory negligence. Such instructions were in open conflict with the purpose and aim of the statute, and, since they may have improperly influenced the result, there must be a new trial.

Koenig v. Patrick Const. Corp., 298 N.Y. 313, 315–16, 317, 318-319 (1948)

Washington’s Negligence Per Se Statutory Provisions

Read the statutory language below and see if you can parse the evidentiary differences and categorical distinctions the legislature has created.

RCWA 5.40.050 5.40.050. Breach of duty—Evidence of negligence—per se
(Effective: July 1, 2010)

A breach of a duty imposed by statute, ordinance, or administrative rule shall not be considered negligence per se, but may be considered by the trier of fact as evidence of negligence; however, any breach of duty as provided by statute, ordinance, or administrative rule relating to:

- (1) Electrical fire safety,
- (2) the use of smoke alarms,
- (3) sterilization of needles and instruments used by persons engaged in the practice of body art, body piercing, tattooing, or electrology, or other precaution against the spread of disease, as required under RCW 70.54.350, or

- (4) driving while under the influence of intoxicating liquor or any drug, shall be considered negligence per se.

Note 1. Negligence Per Se: Different Evidentiary Impact. The Washington state legislature has distinguished among the types of negligence per se available based on certain activities or items, all related to safety or public health. What is the general effect of negligence per se in Washington state? What is the effect of negligence per se with respect to the areas specially enumerated above?

Chester v. Deep Roots Alderwood, LLC, Court of Appeals of Washington, Division 1 (2016) (193 Wash. App. 147)

***150** Anna Chester suffered an adverse reaction after being tattooed with ink that appears to have been contaminated with bacteria when the tattoo artist received it from the distributor. Chester brought negligence claims against the tattoo artist and the tattoo parlor, arguing that they had a duty to use sterile ink. The trial court dismissed her claims on summary judgment and Chester appeals. We affirm, because neither the regulations governing the tattoo industry nor the common law imposes a duty to use sterile ink.

Bonnie Gillson, a tattoo artist, applied a tattoo to Anna Chester at Deep Roots Alderwood, LLC, a shop specializing in tattoos and body piercing. For the black portion of the tattoo, Gillson used One brand tattoo ink. One was a popular ink that Gillson had used for about a year and a half without problem. She ordered the ink from Kingpin Tattoo Supply, a distributor from whom she ordered many tattoo supplies.

A few weeks after applying Chester's tattoo, Gillson learned that several of her clients were experiencing adverse reactions to the black ink portions of their tattoos. An investigation by King County Public Health traced the reactions to a particular bottle of One brand black tattoo ink. The investigation indicated that the ink had likely been contaminated during manufacture. Gillson contacted every client she tattooed during the period of time she used the contaminated bottle of ink. Most clients suffered only a minor skin irritation that did not require medical treatment.

Chester, however, suffered a serious reaction to the contaminated ink. She consulted a doctor who diagnosed a bacterial infection at the tattoo site and prescribed a course of antibiotics. The infection did not respond to the prescribed treatment. Chester's kidney function declined rapidly. In the opinion of Chester's doctor, the bacterial infection aggravated an underlying chronic kidney disease. Chester was eventually referred to an infectious disease ***151** specialist, Dr. Warren L. Dinges. Dinges successfully treated the infection. But before the infection was brought under control Chester's kidneys had failed, requiring her to begin dialysis.

Chester brought product liability and negligence claims against Gillson and Deep Roots.⁹⁹ [***] Gillson and Deep Roots moved for summary judgment. Chester conceded dismissal of her product liability claims, but opposed the motion as to her negligence claims. The trial court found as a matter

⁹⁹ Chester also brought product liability claims against Kingpin and one of Kingpin's suppliers. These claims were not dismissed on summary judgment and are not before this court.

of law that Chester's evidence failed to establish the essential elements of negligence and granted summary judgment for Gillson and Deep Roots. Chester appeals.

[***] ***152** Chester first argues that the respondents were negligent per se because they violated a statutory duty of care. Chester relies on RCW 5.40.050(3), under which the breach of tattooing regulations related to the use of sterile needles is negligence per se. She asserts that WAC 246.145.050(1), which requires that tattoo artists use “sterile instruments and aseptic techniques at all times during a procedure,” imposes a duty to use sterile ink. [...]

The legislature authorized the secretary of the Department of Health to regulate the tattoo industry and instructed the secretary to adopt rules “in accordance with nationally recognized professional standards.” RCW 70.54.340. The legislature further directed the secretary to “consider the standard precautions for infection control, as recommended by the United States centers for disease control.” RCW 70.54.340. In compliance with these directives, the secretary of health adopted chapter 246–145 WAC to regulate electrology, body art, body piercing, and tattooing.

WAC 246–145–050 details 24 “universal precautions” applicable to tattoo artists and body piercers. Three subsections include sterilization requirements. Artists must use ***153** “sterile instruments and aseptic techniques at all times during a procedure.” WAC 246–145–050 (1). They must use only presterilized single-use disposable tattoo needles. WAC 246–145–050 (2). ... The regulation includes two provisions concerning tattoo ink. Tattoo artists must use single-use ink containers for each client to prevent contaminating the unused portion of ink. WAC 246–145–050(15). Artists may not use inks that are banned or restricted by the FDA. WAC 246–145–050(18).¹⁰⁰ The next regulation, WAC 246–145–060, details the requirements for “[s]terile procedures in body art, body piercing and tattooing.” The regulation ... requires artists to reuse only instruments intended for multiple use that have been cleaned and sterilized between clients. WAC 246–145–060(1)(c). The regulation gives specific requirements for sterilizing and storing reusable instruments. WAC 246–145–060(1)(c)–(g). The regulation includes no requirements for ink.

There is no regulation that, by its plain language, creates a duty to use sterile ink. The regulatory scheme as a whole indicates that the secretary carefully considered sterilization as it applies to the tattoo industry. The regulations require that some items be obtained presterilized and that others be sterilized on site, according to detailed procedures. The secretary also considered tattoo ink and issued rules concerning what ink may be used and how ink must be dispensed.

***154** Considering the detail of the regulatory scheme, the specific requirements concerning sterilization, and the attention given to tattoo ink, it is not reasonable to conclude that the secretary intended to require the use of sterile ink but couched that duty within the requirement to use sterile instruments and aseptic techniques. We conclude that the plain language of the regulation is not ambiguous and the legislative intent is clear. There is not a regulatory requirement to use sterile ink.

Chester next argues that the definition section of RCW 70.54.330 is an independent basis for finding the respondents negligent per se. RCW 70.54.330(4) defines “tattooing” as an indelible mark “introduced by insertion of nontoxic dyes or pigments into or under the subcutaneous portion of the

¹⁰⁰ The FDA does not require that tattoo inks be sterile. See Centers for Disease Control, Morbidity and Mortality Weekly Report (MMWR), *Tattoo–Associated Nontuberculous Mycobacterial Skin Infections—Multiple States*, 2011–2012 (August 24, 2012) Vol. 61, No. 33, 653–656 at <http://www.cdc.gov/mmwr/pdf/wk/mm6133.pdf>

skin.” Chester contends that this section creates a duty to use only nontoxic ink and that the respondents breached this duty by using contaminated ink. The respondents argue that the section does not apply to the negligence per se statute, RCW 5.40.050(3). We agree with the respondents.

RCW 5.40.050 establishes negligence per se for the breach of a duty created by statute or rule relating to “(3) sterilization of needles and instruments used by persons engaged in the practice of body art, body piercing, tattooing, or electrology, or other precaution against the spread of disease, as required under RCW 70.54.350.” The referenced statute, RCW 70.54.350 states, “Any person who practices electrology or tattooing shall comply with the rules adopted by the department of health under RCW 70.54.340.” The negligence per se statute thus applies to the breach of any tattooing regulation having to do with precautions against the spread of disease. The definition of tattooing in RCW 70.54.330(4) is not such a regulation.

This reading is in harmony with other statutory and regulatory provisions defining tattooing. RCW 18.300.010, which became effective at the same time as the tattoo regulations, explicitly states that its definitions apply to *155 RCW 5.40.050, the negligence per se statute. The statute defines “tattooing” as “to pierce or puncture the human skin with a needle or other instrument for the purpose of implanting an indelible mark.” RCW 18.300.010(8). The regulations also use this definition. WAC 246–145–010(25). Neither the statutory nor the regulatory definition encompassed by the negligence per se statute includes the word “nontoxic.”

[***] We conclude that Chester has not shown the existence of a statutory duty to use sterile ink and we reject her claim of negligence per se.

Chester argues in the alternative that she established the elements of common law negligence. Chester asserts that even if the respondents owed only a duty of reasonable care, they breached that duty by not using sterile ink or confirming that the ink was not contaminated. Chester does not assert that sterile ink is the industry standard. But she argues that even if sterile ink is not routinely used, the risks associated with using contaminated ink far outweigh the burden of using sterile ink. She argues that the respondents thus breached a duty of reasonable care by failing to ensure the ink they used was sterile.

Chester relies on *Helling v. Carey*, 83 Wash.2d 514 (1974), in which the Supreme Court *156 quoted Judge Learned Hand and followed his cost-benefit analysis.¹⁰¹ *Id.* at 519. In *Helling*, a 32-year-old patient became partially blind due to undetected glaucoma. *Id.* at 516. The defendant ophthalmologists presented evidence that glaucoma is uncommon in young patients and the industry standard was to administer routine glaucoma tests after the age of 40. *Id.* But the court held that, given the severity of glaucoma and the availability of a simple and harmless test to detect the disease, the doctors breached a duty by failing to administer the test. *Id.* at 519.

Chester’s argument falls short because she glosses over the burden of using sterile ink. In *Helling*, it was undisputed that the ophthalmologists could easily administer a simple glaucoma test. *Helling*, 83 Wash.2d at 519. Chester asserts that using sterile ink is similarly easy as “Gillson can simply order sterile rather than non-sterile ink...” She further argues that the respondents had not only a duty to purchase ink advertised as sterile, but also a duty to ensure that ink was in fact sterile. However, Chester

¹⁰¹ Editor’s note: This is a reference to Judge Learned Hand’s negligence calculus, $B < PL$, referred to at the start of Module.

has not shown that sterile ink was widely available at the time in question, that claims of sterility were reliable, or that tattoo artists had the means to test ink for contamination and sterilize it on site.

Chester presented evidence that Intenze brand tattoo ink was advertised as sterile about the time that Gillson purchased the One brand ink. She also produced the article *Microbial status and Product Labelling of 58 original tattoo inks* (2011) as evidence of the association between tattoo ink and bacterial infection. The article reports on a study of 58 inks for sale in the European market. Concerning those inks claiming to be sterile, the authors found that none of the claims could be verified and some were demonstrably false. The authors found that Intenze black ink, advertised as sterile, contained a high level of bacterial contamination.

The record includes a further example of an unreliable claim of sterility. At some point prior to March 2012, *157 the One brand website claimed that its ink was sterile. An inspection determined that, although the manufacturer was having the ink treated with gamma radiation, the dosage of radiation was not sufficient to support the claim of sterility.

Chester has not shown that sterile ink was readily available or that claims of sterility were reliable. She offered no evidence that tattoo artists have the means to test ink for contamination or sterilize ink received from distributors. We conclude that *Helling* is distinguishable. Chester has not established that the respondents' duty of reasonable care required them to use sterile ink.

[***] Affirmed.

Note 1. Common-Law Negligence as Fall-Back If Negligence Per Se Fails. A common mistake is to conclude that the plaintiff's case will fail if the doctrine cannot be applied. Recall that this doctrine operates to ease the burden on the plaintiff and to substitute for—or supplement—the jury's factfinding with guidance from the legislature in areas in which existing laws prescribe the conduct that is reasonable and lawful. Merely because a defendant has *not* been proven to violate a statute, or has violated a statute whose violation fails the four-part applicability analysis does not foreclose the plaintiff's ability to attempt to prove common-law negligence by the defendant. In such cases, the plaintiff will attempt to prove up the defendant's breach as they ordinarily would (through relevant witness and expert testimony, custom evidence where relevant and available, and any other evidence that shows that the defendant was careless in ways that caused the plaintiff's injuries).

Note 2. What is the significance of the court's treatment of *Helling*? Why didn't Chester use custom evidence to prove her case? Does this outcome seem normatively correct or not? Why?

Note 3. Negligence Per Se in Tension with the Reasonable Person Standard. In some respects, the use of negligence per se to determine negligence seizes the question from the jury. (Where the doctrine is used merely to provide evidence of negligence, this is less the case; it merely operates to assist the jury, rather than to usurp its decisional authority.) Courts and commentators have sometimes wondered whether the doctrine should yield to common law standards and grant greater deference to the factfinder in light of tort law's preference for fact-sensitive adjudication in most domains. One area in which courts have acted to limit the scope of negligence per se is in its impact on the reasonable person standard with respect to children, as the next case illustrates.

Bauman v. Crawford, Supreme Court of Washington (1985) (104 Wash.2d 241) En Banc

This appeal requires us to decide whether the negligence per se doctrine should be applicable to minors, or whether minors should instead be judged only by the special child's standard of care in a civil negligence action. We hold that a minor's violation of a statute does not constitute proof of negligence per se, but may, in proper cases, be introduced as evidence of a minor's negligence. Accordingly, we reverse the decision of the Court of Appeals. *Bauman v. Crawford*, 38 Wash. App. 301 (1984).

On April 24, 1979, at approximately 9:30 p.m., the bicycle ridden by petitioner Donald Bauman collided with the automobile driven by respondent. Petitioner was 14 years 4 months old at that time. The collision occurred after dark on a public street in Seattle. Petitioner was riding his bicycle down a steep hill; as he reached the base of the hill, respondent turned left in front of petitioner and the collision resulted. Petitioner's bicycle was equipped with reflectors, but had no headlight. Seattle Municipal Code *243 11.44.160 and RCW 46.61.780(1) each require a headlight on a bicycle operated after dark. In the collision, petitioner suffered a broken lower leg (tibia and fibula) which required three surgeries during the 6 weeks immediately following the accident. Overall, petitioner was hospitalized 10 days, had a cast for about 2 months, and required crutches to ambulate for several weeks after cast removal.

Petitioner, through his guardian ad litem, sued respondent for damages. Respondent's answer alleged contributory negligence by petitioner as an affirmative defense.

The trial court instructed the jury that violation of an ordinance is negligence per se. The court also instructed the jury that the standard of ordinary care for a child is the care that a reasonably careful child of the same age, intelligence, maturity, training and experience would exercise under similar circumstances. The jury rendered a verdict of \$8,000 for petitioner, reduced by 95 percent for petitioner's contributory negligence. Thus, the final verdict was \$400 for petitioner.

Petitioner contends it was reversible error for the court to instruct on negligence per se because he is a minor. He further contends that it was reversible error for the court to give the negligence per se instruction in combination with the special child's standard of care instruction because these instructions are contradictory to one another. Petitioner argued to the Court of Appeals, and now urges before this court, that negligence per se is inapplicable to minors under *all* circumstances. He urges that the special child's standard of care is the proper standard to be applied to a minor, notwithstanding violation of a statute or ordinance.

The Court of Appeals, relying on *Everest v. Riecken*, 30 Wash.2d 683 (1948), declined to hold that the negligence per se doctrine is inapplicable to minors. In *Everest*, this court held that a 15-year-old bicyclist was negligent per se for riding his bicycle after dark without a light, in violation of law. There, this court declined to hold *244 that the child's minority excused him from the operation of the negligence per se doctrine, but did so with no discussion of the policies underlying the negligence per se doctrine or the child's standard of care. After careful reconsideration of those policies, we have determined that the policies underlying the doctrine of negligence per se clash with the policies underlying the special child's standard of care. We therefore overturn the *Everest* case to the extent that it is incompatible with our holding today.

In Washington, a child under 6 years old cannot be held to be contributorially [*sic*] negligent. *Graving v. Dorn*, 63 Wash.2d 236 (1963). Conversely, a 17 or 18-year-old of normal capacity may be treated as an adult in all cases. *Dingwall v. McKerricher*, 75 Wash.2d 352 (1969). Accordingly, the decision in this case applies only to minors 6 to 16 years of age. Generally, contributory negligence of minors in this age group is a question for the trier of fact. *Graving v. Dorn, supra*.

Washington has long recognized the special standard of care applicable to children: a child's conduct is measured by the conduct of a reasonably careful child of the same age, intelligence, maturity, training and experience. *Robinson v. Lindsay*, 92 Wash.2d 410, 412 (1979); *Roth v. Union Depot Co.*, 13 Wash. 525 (1896). The rationale for the special child's standard of care is that a child is lacking in the judgment, discretion, and experience of an adult; thus, the child's standard of care allows for the normal incapacities and indiscretions of youth. [cc] Most significantly, the child's standard was created because public policy dictates that it would be unfair to predicate legal fault upon a standard most children are incapable of meeting. Thus, the fact of minority is not what lowers the standard; rather, the child's immaturity of judgment and lack of capacity to appreciate dangers justifies a special child's standard. *245 [***]

A primary rationale for the negligence per se doctrine is that the Legislature has determined the standard of conduct expected of an ordinary, reasonable person; if one violates a statute, he is no longer a reasonably prudent person. [cc] Negligence per se exists when a statute or ordinance is violated, and that law is designed to (a) protect a class of persons which includes the person whose interest is invaded, (b) protect the particular interest which is invaded, (c) protect against the kind of harm which resulted, and (d) protect that interest against the particular hazard from which the harm results. [c]

A majority of courts in states which apply the negligence per se doctrine to adults have recognized a fundamental conflict between that doctrine and the special child's standard of care. *See Finch v. Christensen*, 84 S.D. 420 (1969) (negligence per se inapplicable to 11-year-old bicyclist riding at night without a light [cc]). Scholarly commentary also overwhelmingly supports the view that negligence per se is inapplicable to children. *See* 37 Tex. L. Rev. 255 (1958); 26 S. Cal. L. Rev. 335 (1953); Annot., *Child's Violation of Statute or Ordinance as Affecting Question of His Negligence or Contributory Negligence*, 174 A.L.R. 1170 (1948); Mertz, *The Infant and Negligence Per Se in Pennsylvania*, 51 Dick. L. Rev. 79 (1946); 3 Vand. L. Rev. 145 (1949).

The majority rule is based upon the policy considerations underlying each doctrine. These courts and commentators recognize that application of negligence per se to children abrogates the special standard of care for children; such *246 abrogation violates the public policy inherent in the special child's standard. These courts and commentators also recognize that refusal to consider a child's minority in effect substitutes a standard of strict liability for the criterion of the reasonable child.

Conversely, the minority of courts willing to impose negligence per se on children do so, for the most part, without discussion of the policy considerations underlying the two doctrines at issue here. Often, a mechanistic statutory construction is applied to foreclose any consideration of the child's maturity level, experience, age, or intelligence. These courts reason that if the legislature did not specifically exclude children from the requirements of the statute, then *all* persons, including children, are required to behave in accordance with that statute. *See Sagor v. Joseph Burnett Co.*, 122 Conn. 447 (1937) (no exception to negligence per se doctrine for children; the terms of the statute are clear and

precise); *D'Ambrosio v. Philadelphia*, 354 Pa. 403 (1946) (the law applies equally to adults and children unless it specifically excludes children).

Similarly, the Court of Appeals in the present case was persuaded that the Washington Legislature intended that children be held negligent per se for violation of the statute involved in this case. In 1965 the Legislature repealed RCW 46.47.090 which specifically stated that no child under 16 shall be held to be negligent per se for any violation of the statute. [***] The Court of Appeals interprets this deletion from the statute as proof that the Legislature intends that negligence per se be applied whenever the statute is violated by a child. [***] The legislative history of the repealed provision is *247 unavailable, so it is impossible to ascertain the actual legislative intent. It is significant, however, that the entire motor vehicle code was being revised at the time this provision was repealed. Thus, the Legislature did not single out this statute for special treatment, but merely changed it as part of an overall revamping of the code. Furthermore, negligence per se and the child's standard of care are both court-created doctrines. Accordingly, we presume the Legislature, by its change, intended to return to the courts the decision whether to apply negligence per se to minors under 16 years of age.

A significant number of the courts which decline to apply negligence per se to minors have determined that violation of a statute by a minor may be introduced as evidence of negligence, as long as the jury is clearly instructed that the minor's behavior is ultimately to be judged by the special child's standard of care. [cc]

We agree with these courts that allowing a statutory violation to be introduced simply as one factor to be considered by the trier of fact is an equitable resolution of the dilemma created by a minor's violation of law. We therefore remand for a new trial on the issue of liability under proper instructions. At that trial the jury must be instructed as to the special child's standard of care. The jury may then be instructed that violation of a relevant statute¹⁰² may be considered *248 as evidence of negligence only if the jury finds that a reasonable child of the same age, intelligence, maturity and experience as petitioner would not have acted in violation of the statute under the same circumstances.

[***] [W]e hold that our ruling today, which exempts minors from the operation of the negligence per se doctrine, shall apply prospectively. However, the rule shall also apply to any case already tried where the issue of the doctrine's application to a minor was preserved for appeal.

BRACHTENBACH, Justice (concurring).

I concur in the rationale and result of the majority but I am convinced that in the appropriate case this court should reexamine the entire theory of negligence per se arising from the alleged violation of a statute, an ordinance or an administrative regulation. This court has long been committed to the rule that violation of a positive statute constitutes negligence per se. In *Engelker v. Seattle Elec. Co.*, 50 Wash. 196 (1908), the court noted that some jurisdictions follow the rule that a violation of a statute is mere evidence of negligence but it adopted the doctrine "that a thing which is done in violation of positive law is in itself negligence." *Engelker*, at 199. This rule has been applied to violations of statutes, ordinances and regulations, *Cook v. Seidenverg*, 36 Wash.2d 256 (1950) [***] The

¹⁰² A statute must still be shown to be applicable under the negligence per se test before its violation may be introduced even as mere evidence of negligence. That is, the statute must be designed to protect the proper class of persons, to protect the particular interest involved, and to protect against the harm which results. See *Young v. Caravan Corp.*, 99 Wash.2d 655, 663 P.2d 834 (1983). Thus, only relevant statutory violations will be admitted.

Restatement (Second) of Torts § 286 (1965) adopted the test of the relevancy of the statute to the tortious action. Where the relevancy test is met and where there exists prima facie a discernible causal connection between the violation of the statute and the injury, the jury is properly advised that the violation amounts to negligence per se and proximate cause then *250 becomes the sole issue of fact to be resolved by the trier of fact. [***]

The rule, however, has not been applied with relentless indifference to actual fault. A violation of statute has been held not to constitute negligence per se where the violation is due to some cause beyond the violator's control, and which reasonable prudence could not have guarded against [c]; where the violation is due to an emergency [c]; where the violation is merely technical; where the violation is perpetuated out of necessity [c]; or where the violator is not given notice that his actions were in violation of the law [c].

[***] This 77-year-old doctrine has been the subject of exceptions almost since its adoption. Perhaps it is time we stopped selectively placing the negligence question within "rational judicial control" and place it, in all cases, in the rational control of the trier of fact, where it belongs.

The finding of negligence is normally a task for the trier of fact. Through the application of the negligence per se doctrine we have taken that task away from the jury and the court now decides when a violation of statute constitutes negligence. It is evident from the numerous exceptions to the doctrine that the court is not merely applying a statute to the tortious action, but determining from the total factual circumstances whether or not the statute violator *251 was negligent at all. I, therefore, advocate true rational control of the negligence doctrine through the return of the negligence question to the trier of fact in cases involving evidence of a violation of statute.

Currently, the majority of American jurisdictions follow the negligence per se doctrine and find that a breach of statutory duty is a breach of standard of care for civil negligence cases. Seven states follow the theory that a breach of a statutory duty is evidence of negligence in civil action,¹⁰³ while five states hold that a violation of a statute is prima facie negligence which may be rebutted by competent evidence.¹⁰⁴ In addition, some of the courts which follow the majority rule as to statutes have held that the breach of ordinances, or traffic laws, or the regulations of administrative bodies is only evidence for the jury. Such cases seem to indicate a desire to leave some leeway for cases where a violation may not be necessarily unreasonable. [c]

The English rule is to consider a breach of a statutory duty a tort in itself. The Canadian Supreme Court recently reviewed both the English rule and the American rules and chose to follow the American minority rule which considers the violation to be mere evidence of negligence. *The Queen v. Saskatchewan Wheat Pool*, 143 D.L.R.3d 9 (1983); see also Note, *Negligence and Breach of Statutory Duty*, 4 Oxford J. Legal Stud. 429 (1984). As indicated by the Canadian decision, criticism of the *252 negligence per se doctrine is mounting in the courts. Authors of treatises and journal articles

¹⁰³ *Franco v. Bunyard*, 261 Ark. 144, cert. denied, 434 U.S. 835, (1977); *Eagan v. Marr Scaffolding Co.*, 14 Mass. App. 1036 (1982), review denied, 445 N.E.2d 156 (1983); *Fisher v. O'Connor's, Inc.*, 53 Md. App. 338 (1982); *Florida v. Farlee*, 201 Neb. 39 (1978); *Braitman v. Overlook Terrace Corp.*, 68 N.J. 368 (1975); *Burns v. Bombard*, 128 Vt. 178, 260 A.2d 219 (1969); *Distad v. Cubin*, 633 P.2d 167 (Wyo.1981).

¹⁰⁴ *Stephens v. State*, 440 So.2d 920 (La.Ct.App.1983), cert. denied, 443 So.2d 1119 (1984); *Agnello v. Puzzo*, 110 Ill.App.3d 913 (1982); *Dongo v. Banks*, 448 A.2d 885 (Me.1982); *Hall v. Warren*, 632 P.2d 848 (Utah 1981); *Vandergrift v. Johnson*, 157 W.Va. 958 (1974).

are also increasingly critical of the doctrine and write favorably of the evidence-of-negligence doctrine. Objection is made to the court's inferring a legislative intent to create a standard of care in civil cases where the Legislature is silent. The main criticism is that it is difficult to discover the bases on which the courts either find or refuse to find these fictional intentions. Alexander, *Legislation and the Standard of Care in Negligence*, 42 Can. B. Rev. 243 (1964).

The most widely accepted rationale for the negligence per se rule is that the reasonable man always obeys the criminal law, thus, a breach of the criminal law must be unreasonable and, therefore, negligent. Thayer, *Public Wrong and Private Action*, 27 Harv. L. Rev. 317 (1913–14). The basic flaw in this rationale and in inferring legislative intent is the fact that the criminal proscriptions may be ill conceived, hastily drawn with inadequate investigation or obsolete and, yet, the validity of the statute will not be before the court in the negligence action. The Legislature has not considered the policy problems peculiar to civil liability nor has it composed the legislation in terms of a standard of due care in damage suits or for judging negligence. Morris, *The Role of Criminal Statutes in Negligence Actions*, 49 Colum. L. Rev. 21, 39–43 (1949). Reliance on the Legislature for a standard of reasonableness under these circumstances would not make for the wisest decision.

A second rationale for finding legislative intent to create a standard of care in civil cases is that the Legislature recognizes that the negligence per se rule is needed to promote and fulfill reliance by others on uniform obedience to statutes. However, where the Legislature does not explicitly impose automatic liability in a civil action as a sanction, the court is encroaching on legislative territory when it adds such a sanction for the purposes of law enforcement. Further, “[n]either in fact nor in law do others have the right under all circumstances to rely on the actor’s obedience to statute.” [c]

***253** Further criticism of the negligence per se doctrine arises because of the differences between the criminal and civil systems. Lawmakers may be contented with a broad unqualified requirement in a criminal statute because they knew that enforcement officials would use their discretion to make exceptions in cases where literal compliance made no sense or worked a hardship. In a civil action on the other hand, where large damages are often at stake, the injured party cannot be expected to jeopardize his claim by forgiving noncompliance in exceptional cases, as a public prosecutor would. [c]. Additionally, civil defendants do not have the ability to avail themselves of criminal procedural defenses and protections against an inflexible application of the criminal standard.

Criticism is also made because of the imposition of liability without fault. As noted above, the Washington courts have joined in this criticism and produced multiple exceptions in order to avoid this aspect of the doctrine. This exception-finding approach produces a weakened doctrine and ultimately places the jury’s task of determining negligence with the court under all circumstances. Such an approach also leads to distorted statutory construction which affects the criminal law as well.

The defect in our prior reasoning is that the negligence per se doctrine removes the determination of negligence from the fact-finding function of the jury, or the court sitting as a fact finder. While it is a convenient method to affix liability, it runs counter to the basic notion of determining tort liability. I would prospectively limit the doctrine to an evidence of negligence standard.

Note 1. In some instances, a statutory violation may be used to establish duty; in others, it may be used as evidence of breach (or as conclusive of breach). What is the practical difference?

Note 2. Rationales For Negligence Per Se. *Bauman* observes variations in 12 states and three countries relative to how they consider and apply negligence per se. Identify the rationales for the doctrine. Are you more persuaded by the rationales for negligence per se or by critiques of the doctrine?

Note 3. Authority Issues. The theme of *Palsgraf's* fight over decisional authority on the question of negligence continues. Does it strike you as fair, efficient or otherwise good for tort law to use negligence per se to determine breach? How about merely to offer evidence of breach? Would you distinguish its use based on the kind of statute? The category of harm? The kind of actor alleged to have breached their duty or violated the statute?

Note 4. Excuse. *Bauman* identifies a number of instances in which the violation of a statute may be excused. What are they?

Excused Violations, Restatement (Third) of Torts § 15.

Restatement (3d) of Torts: Liability for Physical Harm (adopted 2005; published 2010)

An actor's violation of a statute is excused and not negligence if:

- (a) the violation is reasonable in light of the actor's childhood, physical disability, or physical incapacitation;
- (b) the actor exercises reasonable care in attempting to comply with the statute;
- (c) the actor neither knows nor should know of the factual circumstances that render the statute applicable;
- (d) the actor's violation of the statute is due to the confusing way in which the requirements of the statute are presented to the public; or
- (e) the actor's compliance with the statute would involve a greater risk of physical harm to the actor or to others than noncompliance.

Is the use of negligence per se, and the corresponding creation of rules of law that recognize excuses for violation, effectively converting breach into a categorical inquiry, like duty? What do you think of this in terms of your understanding of the proper role for the judge and jury? The next case is a classic opinion on these issues, brought to you again by Justice Cardozo.

Martin v. Herzog, Court of Appeals of New York (1920) (228 N.Y. 164)

The action is one to recover damages for injuries resulting in death.

Plaintiff and her husband, while driving toward Tarrytown in a buggy on the night of August 21, 1915, were struck by the defendant's automobile coming in the opposite direction. They were thrown to the ground, and the man was killed. At the point of the collision the highway makes a curve. The car was rounding the curve, when suddenly it came upon the buggy, emerging, the defendant tells us, from the gloom. Negligence is charged against the defendant, the driver of the car, in that he did not keep to the right of the center of the highway. Highway Law, § 286, subd. 3, and section 332 (Consol. Laws, c.

25). Negligence is charged against the plaintiff's intestate, the driver of the wagon, in that he was traveling without lights. Highway Law, § 329a, as amended by Laws 1915, c. 367.

There is no evidence *167 that the defendant was moving at an excessive speed. There is none of any defect in the equipment of his car. The beam of light from his lamps pointed to the right as the wheels of his car turned along the curve toward the left; and, looking in the direction of the plaintiff's approach, he was peering into the shadow. The case against him must stand, therefore, if at all, upon the divergence of his course from the center of the highway. The jury found him delinquent and his victim blameless. The Appellate Division reversed, and ordered a new trial.

We agree with the Appellate Division that the charge to the jury was erroneous and misleading. [***] In the body of the charge the trial judge said that the jury could consider the absence of light 'in determining whether the plaintiff's intestate was guilty of contributory negligence in failing to have a light upon the buggy as provided by law. I do not mean to say that the absence of light necessarily makes him negligent, but it is a fact for your consideration.'

The defendant requested a ruling that the absence of a light on the plaintiff's vehicle was 'prima facie evidence of contributory negligence.' This request was refused, and the jury were again instructed that they might consider the absence of lights as some evidence of negligence, but that it was not conclusive evidence.

The plaintiff then requested a charge that 'the fact that the plaintiff's intestate was driving without a light is not negligence in itself,' and to this the court acceded. The defendant saved his rights by appropriate exceptions.

*168 We think the unexcused omission of the statutory signals is more than some evidence of negligence. It *is* negligence in itself.

Lights are intended for the guidance and protection of other travelers on the highway. Highway Law, § 329a. By the very terms of the hypothesis, to omit, willfully or heedlessly, the safeguards prescribed by law for the benefit of another that he may be preserved in life or limb, is to fall short of the standard of diligence to which those who live in organized society are under a duty to conform. That, we think, is now the established rule in this state. [***]

A rule less rigid has been applied where the one who complains of the omission is not a member of the class for whose protection the safeguard is designed. [***] In the case at hand, we have an instance of the admitted violation of a statute intended for the protection of travelers on the highway, of whom the defendant at the time was one. Yet the jurors were instructed in effect that they were at liberty in their discretion to treat the omission of lights either as innocent or as culpable. They were allowed to 'consider the default as lightly or gravely' as they would (Thomas, J., in the court below). They might as well have been told that they could use a like discretion in holding a master at fault for the omission of a safety appliance prescribed by positive law for the protection of a workman. Jurors have no dispensing power, by which they may relax the duty that one traveler on the highway owes *170 under the statute to another. It is error to tell them that they have. The omission of these lights was a wrong, and, being wholly unexcused, was also a negligent wrong. No license should have been conceded to the triers of the facts to find it anything else.

We must be on our guard, however, against confusing the question of negligence with that of the causal connection between the negligence and the injury. A defendant who travels without lights is not to pay damages for his fault, unless the absence of lights is the cause of the disaster. A plaintiff who travels without them is not to forfeit the right to damages, unless the absence of lights is at least a contributing cause of the disaster. To say that conduct is negligence is not to say that it is always contributory negligence. ‘Proof of negligence in the air, so to speak, will not do.’ Pollock Torts (10th Ed.) p. 472.

We think, however, that evidence of a collision occurring more than an hour after sundown between a car and an unseen buggy, proceeding without lights, is evidence from which a causal connection may be inferred between the collision and the lack of signals. [c] If nothing else is shown to break the connection, we have a case, prima facie sufficient, of negligence contributing to the result.

There may, indeed, be times when the lights on a highway are so many and so bright that lights on a wagon are superfluous. If that is so, it is for the offender to go forward with the evidence, and prove the illumination as a kind of substituted performance. The plaintiff asserts that she did so here. She says that the scene of the accident was illumined by moonlight, by an electric lamp, and by the lights of the approaching car. Her position is that, if the defendant did not see the buggy thus illumined, a jury might reasonably infer that he would not have seen *171 it anyhow. We may doubt whether there is any evidence of illumination sufficient to sustain the jury in drawing such an inference; but the decision of the case does not make it necessary to resolve the doubt, and so we leave it open. It is certain that they were not required to find that lights on the wagon were superfluous. They might reasonably have found the contrary. They ought, therefore, to have been informed what effect they were free to give, in that event, to the violation of the statute. They should have been told, not only that the omission of the light was negligence, but that it was ‘prima facie evidence of contributory negligence’; i. e., that it was sufficient in itself unless its probative force was overcome (Thomas, J., in court below) to sustain a verdict that the decedent was at fault. [c]

Here, on the undisputed facts, lack of vision, whether excusable or not, was the cause of the disaster. The defendant may have been negligent in swerving from the center of the road; but he did not run into the buggy purposely, nor was he driving while intoxicated, nor was he going at such a reckless speed that warning would of necessity have been futile. Nothing of the kind is shown. The collision was due to his failure to see at a time when sight should have been aroused and guided by the statutory warnings. Some explanation of the effect to be given to the absence of those warnings, if the plaintiff failed to prove that other lights on the car or the highway took their place as equivalents, should have been put before the jury. The explanation was asked for and refused.

We are persuaded that the tendency of the charge, and of all the rulings, following it, was to minimize unduly, in the minds of the triers of the facts, the gravity of the decedent’s fault. Errors may not be ignored as unsubstantial, when they tend to such an outcome. A statute designed for the protection of human life is not to be brushed aside as a form of words, its commands reduced *172 to the level of cautions, and the duty to obey attenuated into an option to conform.

The order of the Appellate Division should be affirmed, and judgment absolute directed on the stipulation in favor of the defendant, with costs in all courts.

HOGAN, J. (dissenting).

Upon the trial of this action, a jury rendered a verdict in favor of the plaintiff. Defendant appealed from the judgment entered thereon, and an order made denying an application to set aside the verdict and for a new trial, to the Appellate Division. The latter court reversed the judgment on the law, and granted a new trial on questions of law only; the court having examined the facts and found no error therein. The decision thus made was equivalent to a determination by the court that it had passed upon the question of the sufficiency of the evidence, and as to whether the verdict rendered by the jury was against the weight of evidence. The effect of that decision was that the order denying the motion to set aside the verdict and grant a new trial was upon the facts properly denied. *Judson v. Central Vt. R. Co.*, 158 N. Y. 597, 602. A jury and the Appellate Division having determined that, upon the facts developed on the trial of the action, the plaintiff was entitled to recover, in view of certain statements in the prevailing opinion, and for the purpose of explanation of my dissent, I shall refer to the facts which were of necessity found in favor of plaintiff, and approved by the Appellate Division. The following facts are undisputed:

Leading from Broadway, in the village of Tarrytown, Westchester county, is a certain public highway, known as Neperham road, \ which runs in an easterly direction to East View, town of Greenburg. The worked portion of the highway varies in width from 21 1/2 feet at the narrowest point, a short distance easterly of the place of the collision hereinafter mentioned, to a width of *173 27 1/2 feet at the point where the collision occurred.

On the evening of August 21, 1915, the plaintiff, together with her husband, now deceased, were seated in an open wagon drawn by a horse. They were traveling on the highway westerly towards Tarrytown. The defendant was traveling alone on the highway in the opposite direction, viz. from Tarrytown easterly towards East View, in an automobile which weighed about 3,000 pounds, having a capacity of 70 horse power, capable of developing a speed of 75 miles an hour. Defendant was driving the car.

A collision occurred between the two vehicles on the highway, at or near a hydrant located on the northerly side of the road. Plaintiff and her husband were thrown from the wagon in which they were seated. Plaintiff was bruised and her shoulder dislocated. Her husband was seriously injured and died as a result of the accident. The plaintiff, as administratrix, brought this action to recover damages arising by reason of the death of her husband, caused, as she alleged, solely by the negligence of defendant in operating, driving, and running the automobile at a high, unlawful, excessive, and unsafe rate of speed, in failing to blow a horn or give any warning or signal of the approach of said automobile, and in operating, driving, and riding said automobile at said time and place upon his left-hand or wrongful side of said road or highway, thereby causing the death of her husband.

Defendant by his answer admitted that he was operating the automobile, put in issue the remaining allegations of the complaint, and affirmatively alleged that any injury to plaintiff's intestate was caused by his contributory negligence. As indicated in the prevailing opinion, the manner in which the accident happened and the point in the highway where the collision occurred are important facts in this case, for as therein stated:

‘The case against him [defendant] *174 must stand, therefore, if at all, upon the divergence of his course from the center of the highway.’

The evidence on behalf of plaintiff tended to establish that on the evening in question her husband was driving the horse at a jogging gait along on the right side of the highway near the grass, which was

outside of the worked part of the road on the northerly side thereof; that plaintiff observed about 120 feet down the road the automobile operated by defendant approaching at a high rate of speed, two searchlights upon the same, and that the car seemed to be upon her side of the road; that the automobile ran into the wagon in which plaintiff and her husband were seated at a point on their side of the road, while they were riding along near the grass. Evidence was also presented tending to show that the rate of speed of the automobile was 18 to 20 miles an hour and the lights upon the car illuminated the entire road. The defendant was the sole witness on the part of the defense upon the subject under consideration. His version was:

‘Just before I passed the Tarrytown Heights station, I noticed a number of children playing in the road. I slowed my car down a little more than I had been running. I continued to drive along the road; probably I proceeded along the road 300 or 400 feet further, I do not know exactly how far, when suddenly there was a crash, and I stopped my car as soon as I could after I realized that there had been a collision. Whether I saw anything in that imperceptible fraction of space before the wagon and car came together I do not know. I have an impression, about a quarter of a second before the collision took place, I saw something white cross the road and heard somebody call ‘whoa,’ and that is all I knew until I stopped my car. * * * My best judgment is I was traveling about 12 miles an hour. * * * At the time of the collision I was driving on the right of the road.’

***175** The manner in which and the point in the highway where the accident occurred presented a question of fact for a jury. If the testimony of defendant was accredited by the jury, plaintiff and her intestate, having observed the approaching automobile deliberately, thoughtlessly, or with an intention to avoid the same, left their side of the road at a moment when an automobile was rapidly approaching with lights illuminating the road, to cross over to the side of the highway where the automobile should be, and as claimed by defendant was traveling, and thereby collided with the same, or, on the contrary, defendant was driving upon his left side of the road and caused the collision.

The trial justice charged the jury fully as to the claims of the parties, and also charged that the plaintiff in her complaint specifically alleged the acts constituting negligence on the part of defendant (amongst which was that he was driving on the wrong side of the road, thereby causing the death of her husband, the alleged absence of signals having been eliminated from the case), and in order to recover the plaintiff must show that the accident happened in the way and in the manner she has alleged in her complaint.

‘It is for you to determine whether the defendant was driving on the wrong side of the road at the time he collided with the buggy; whether his lights did light up the road, and the whole road, ahead of him to the extent that the buggy was visible, and so, if he negligently approached the buggy in which plaintiff and her husband were driving at the time. If you find, from the evidence here, he was driving on the wrong side of the road, and that for this reason he collided with the buggy, which was proceeding on the proper side, or if you find that as he approached the buggy the road was so well lighted up that he saw or should have seen the buggy, and yet collided with it, then you may say, if you so find, that the defendant was careless and negligent.’

No exception was taken by the defendant to that charge, but at the ***176** close of the charge counsel for defendant made certain requests to charge upon the subject as follows:

‘(1) If the jury find that Mr. Martin was guilty of any negligence, no matter how slight, which contributed to the accident, the verdict must be for defendant.

‘(2) In considering the photographs, and consideration of which side of the vehicle, wagon, was damaged, that the jury have no right to disregard physical facts, and unless they find the accident happened as described by Mrs. Martin and Mrs. Cain, the verdict must be for the defendant.

‘(3) The plaintiff must stand or fall on her claim as made, and, if the jury do not find that the accident happened as substantially claimed by her and her witnesses, that the verdict of the jury must be for defendant.

‘(4) It was the duty of Mr. Martin to keep to the right.’

Each one of the several requests was charged, and in addition the trial justice charged that if the deceased, Mr. Martin, collided with the automobile while the wagon was on the wrong side of the road, the verdict must be for defendant. The principal issue of fact was not only presented to the jury in the original charge made by the trial justice, but emphasized and concurred in by counsel for defendant. The prevailing opinion, in referring to the accident and the highway at the point where the accident occurred, describes the same in the following language:

‘At the point of the collision the highway makes a curve. The car was rounding the curve, when suddenly it came upon the buggy, emerging, the defendant tells us, from the gloom.’

Such in substance was the testimony of the defendant, but his version was rejected by the jurors and the Appellate Division, and the evidence in the record is ample to sustain a contrary conclusion. As to the statement that the car was rounding ‘a curve, ‘*177 two maps made by engineers from actual measurements and surveys for defendant were put in evidence by counsel for plaintiff. Certain photographs, made for the purposes of the trial, were also before the jury. I think we may assume that the jurors gave credence to the maps and actual measurements, rather than to the photographs, and failed to discover therefrom a curve of any importance, or which would interfere with an unobstructed view of the road. As to the ‘buggy emerging, the defendant tells us, from the gloom,’ evidence was adduced by plaintiff tending to show that the searchlights on defendant’s car lighted up the entire roadway to the extent that the vehicle in which plaintiff and her husband were riding was visible; that the evening was not dark, though it appeared as though a rainfall might be expected. Some witnesses testified it was moonlight. The doctor called from Tarrytown, who arrived within 20 minutes after the collision, testified that the electric lights all along the highway were burning as he passed over the road. The width of the worked part of the highway at the point of the accident was 27 1/2 feet. About 25 feet westerly on the southerly side was located an electric light, which was burning. A line drawn across the highway from that light to the point of the accident would be about 42 feet.

One witness called by plaintiff lived in a house directly across the highway from the point of the accident. Seated in a front room, it was sufficiently light for her to see plaintiff’s intestate when he was driving along the road at a point near a telegraph pole, which is shown on the map some 90 or 100 feet easterly of the point of the accident, when she observed him turn his horse into the right towards the fence. Soon thereafter she heard the crash of the collision, and immediately went across the highway and found Mr. Martin in a sitting position on the grass. A witness called by the *178 defendant testified

that she was on the stoop of her house, which is across the highway from the point of the accident and about 40 feet distant from said point, and while seated there she could see the body of Mr. Martin. While she testified the evening was dark, the lights on the highway were sufficient to enable her to see the body of Mr. Martin lying upon the grass 40 feet distant. The defendant upon cross-examination was confronted with his testimony given before the coroner, where he testified that the road was 'fairly light.'

The facts narrated were passed upon by the jury under a proper charge relating to the same, and were sustained by the Appellate Division. The conclusions deducible therefrom are: (a) Defendant was driving his car upon the wrong side of the road. (b) Plaintiff and her intestate were driving a horse attached to the wagon in which they were seated upon the extreme right side of the road. (c) The highway was well lighted. The evening was not dark. (d) Defendant collided with the vehicle in which plaintiff and her husband were riding and caused the accident.

I must here note the fact that concededly there was no light upon the wagon in which plaintiff and her husband were riding, in order that I may express my views upon additional phrases in the prevailing opinion Therein it is stated:

*819 'there may, indeed, be times when the lights on a highway are so many and so bright that lights on a wagon are superfluous.'

I am in accord with that statement, but I dissent from the suggestion we may doubt whether there is any evidence of illumination sufficient to sustain the jury in drawing the inference that, if defendant did not see the buggy thus illumined, it might reasonably infer that he would not have seen it anyway. Further the opinion states:

'Here on the undisputed facts lack of vision, whether excusable or not, was the cause of the disaster. The defendant may have been negligent in swerving from the center of the road, but *179 did not run into the buggy purposely, nor was he driving while intoxicated, nor was he going at such a reckless rate of speed that warning would of necessity be futile. Nothing of this kind is shown.'

As to the rate of speed of the automobile, the evidence adduced by plaintiff's witnesses was from 18 to 20 miles an hour, as 'very fast'; further that after the collision the car proceeded 100 feet before it was stopped. The defendant testified that he was driving about 12 miles an hour, that at such rate of speed he thought the car should be stopped in 5 or 6 feet, and though he put on the foot brake, he ran 20 feet before he stopped. The jury had the right to find that a car traveling at the rate of 12 miles an hour, which could be stopped within 5 or 6 feet, and with the foot brake on, was not halted within 100 feet, must at the time of the collision have been running 'very fast,' or at a reckless rate of speed, and therefore warning would of necessity be futile. No claim was made that defendant was intoxicated, or that he purposely ran into the buggy. Nor was proof of such facts essential to plaintiff's right to recover. This case does not differ from many others, wherein the failure to exercise reasonable care to observe a condition is disclosed by evidence and properly held a question of fact for a jury. In the earlier part of the prevailing opinion, as I have pointed out, the statement was:

'The case against him [defendant] must stand or fall, if at all, upon the divergence of his course from the center of the highway.'

It would appear that 'lack of vision, whether excusable or not, was the cause of the disaster,' had been adopted in lieu of divergence from the center of the highway. I have therefore discussed divergence from the center of the road.

[***] My examination of the record leads me to the conclusion that lack of vision was not, on the undisputed facts, the sole cause of the disaster. Had the defendant been upon his right side of the road, upon the plaintiff's theory he might have been driving recklessly, *180 and, the plaintiff and her intestate being near to the grass on the northerly side of a roadway 27 feet and upwards in width, the accident would not have happened, and the presence of or lack of vision would not be material. If, however, as found by the jury, defendant was wrongfully on plaintiff's side of the road and caused the accident, the question of whether or not, under the facts, in the exercise of reasonable care, he might have discovered his error and the presence of plaintiff, and thereupon avoid the collision, was for the jury. The question was presented whether or not, as defendant approached the wagon, the roadway was so well lighted up that defendant saw, or in the exercise of reasonable care could have seen, the wagon in time to avoid colliding with the same, and upon that proposition the conclusion of the jury was adverse to defendant, thereby establishing that the lights of the car on the highway were equivalent to any light which, if placed upon the wagon of plaintiff, would have aroused the attention of defendant, and that no causal connection existed between the collision and absence of a light on the wagon.

At the close of the charge to the jury the trial justice was requested by counsel for defendant to charge:

'That the failure to have a light on plaintiff's vehicle is prima facie evidence of contributory negligence on the part of plaintiff.'

The justice declined to charge in the language stated, but did charge that the jury might consider it on the question of negligence, but it was not in itself conclusive evidence of negligence. For the refusal to instruct the jury as requested, the judgment of the Trial Term was reversed by the Appellate Division.

The request to charge was a mere abstract proposition. Even assuming that such was the law, it would not bar a recovery by plaintiff, unless such contributory negligence was the proximate and not a remote contributory cause of the injury. [***] The *181 request to charge excluded that important requisite. The trial justice charged the jury that the burden rested upon plaintiff to establish by the greater weight of evidence that plaintiff's intestate's death was caused by the negligence of the defendant and that such negligence was the proximate cause of his death; that by 'proximate cause,' is meant that cause without which the injury would not have happened, otherwise she could not recover in the action. In the course of his charge the justice enlarged on the subject of contributory negligence, and in connection therewith read to the jury the provisions of the highway law, and then charged that the jury should consider the absence of a light upon the wagon in which plaintiff and her intestate were riding and whether the absence of a light on the wagon contributed to the accident.

At the request of counsel for defendant, the justice charged that, if the jury should find any negligence on the part of Mr. Martin, no matter how slight, contributed to the accident, the verdict must be for the defendant. I cannot concur that we may infer that the absence of a light on the front of the wagon was not only the cause, but the proximate cause, of the accident. Upon the evidence adduced upon the trial and the credence attached to the same, the fact has been determined that the accident would have been avoided, had the defendant been upon his side of the road, or attentive to where he was driving along a public highway, or had he been driving slowly, used his sense of sight, and observed plaintiff and her intestate as he approached them; they being visible at the time.

The defendant's request to charge, which was granted, 'that plaintiff must stand or fall on her claim as made, and, if the jury do not find that the accident happened as substantially claimed by her and her witnesses, that the verdict of the jury must be for the defendant,' presented the question quite succinctly. The jury found that the accident happened as claimed by the plaintiff and her witnesses, and we cannot surmise or *182 infer that the accident would not have happened, had a light been located on the wagon. [***]

It would not be profitable to refer to and analyze the numerous decisions of this court upon the effect of a violation of an ordinance or a statute. A large number of cases were cited in the opinions in the Amberg Case. That case was decided upon the principle that, where a duty is imposed by statute and a violation of the duty causes an injury, such violation is evidence of negligence as matter of law. [***] The charge requested and denied in this case was in effect that a failure to have a light upon the intestate's wagon was as matter of law such negligence on his part as to defeat the cause of action, irrespective of whether or not such negligence was the proximate cause of the injury. My conclusion is that we are substituting form and phrases for substance, and diverging from the rule of causal connection.

Order affirmed.

Note 1. What differences stood out to you in the two descriptions of fact represented in the majority and dissenting opinions? Which strikes you as more careful? Which seems more persuasive?

Note 2. What is the legal significance of the plaintiff's allegation that "the scene of the accident was illumined by moonlight, by an electric lamp, and by the lights of the approaching car"?

Note 3. What precisely was the error in the instruction to the jury, according to the majority opinion?

Res Ipsa Loquitur ("RIL"). This phrase is Latin for "the thing speaks for itself." Its use traces to a 19th-century British case, *Byrne v. Boadle*, where it may have been intended to do no more than provide fancy Latin dicta suggestive of the court's rationale. (There are also theories that it intentionally sought to expand liability and codify a series of earlier rulings; it is not entirely clear). Whatever the intended purpose of the phrase, it has since evolved into something besides a mere placeholder or explanation. Some courts treat it as a substantive doctrine and others as a rule of evidence (whose precise effect varies by jurisdiction). In this casebook, we will treat it as a rule of evidence with important substantive implications. In brief, when evidence regarding the defendant's breach of due care is unavailable, mysterious, or inaccessible to plaintiff but not defendant, the RIL may be deemed applicable by a judge (and then sent to be applied by the jury, in most cases). The effect and operation of the doctrine vary, but in all cases, its purpose is to help a party (usually the plaintiff) whose case is otherwise fatally flawed on the question of what happened, or how their injuries came to about as a function of the defendant's negligence. Because RIL is being used to help the plaintiff's case in some way, it is usually applied narrowly; not every mysterious accident applies. The next case is commonly credited with being the source of the doctrine.

Byrne v. Boadle, Court of Exchequer (1863)
(2 H. & C. 722, 159 Eng.Rep. 299)

[Action for negligence. The plaintiff's evidence was that he was walking in a public street past the defendant's shop, and that a barrel of flour fell upon him from a window above the shop, knocked him down, and seriously injured him. There was no other evidence. The Assessor was of the opinion that there was no evidence of negligence for the jury, and nonsuited the plaintiff, reserving leave to him to move the Court of Exchequer to enter the verdict for him for £50 damages. Plaintiff obtained a rule nisi.]

Charles Russell [attorney for defendant] now shewed cause.

First, there was no evidence to connect the defendant or his servants with the occurrence. It is consistent with the evidence that the purchaser of the flour was superintending the lowering of it by his servant, or it may be that a stranger was engaged to do it without the knowledge or authority of the defendant. [Pollock, C.B. The presumption is that the defendant's servants were engaged in removing the defendant's flour; if they were not it was competent to the defendant to prove it.]

Secondly, assuming the facts to be brought home to the defendant or his servants, these facts do not disclose any evidence for the jury of negligence. The plaintiff was bound to give affirmative proof of negligence. But there was not a scintilla of evidence, unless the occurrence is of itself evidence of negligence. There was not even evidence that the barrel was being lowered by a jigger-hoist as alleged in the declaration. [Pollock, C.B. There are certain cases of which it may be said *res ipsa loquitur*, and this seems one of them. In some cases the Courts have held that the mere fact of the accident having occurred is evidence of negligence, as, for instance, in the case of railway collisions.]

POLLOCK, C.B. We are all of opinion that the rule must be absolute to enter the verdict for the plaintiff. The learned counsel was quite right in saying that there are many accidents from which no presumption of negligence can arise, but I think it would be wrong to lay down as a rule that in no case can a presumption of negligence arise from the fact of an accident. Suppose in this case the barrel had rolled out of the warehouse and fallen on the plaintiff, how could he possibly ascertain from what cause it occurred? It is the duty of persons who keep barrels in a warehouse to take care that they do not roll out, and I think that such a case would, beyond all doubt, afford *prima facie* evidence of negligence. A barrel could not roll out of a warehouse without some negligence, and to say that a plaintiff who is injured by it must call witnesses from the warehouse to prove negligence seems to me preposterous. * * * The present case upon the evidence comes to this, a man is passing in front of the premises of a dealer in flour, and there falls down upon him a barrel of flour. I think it apparent that the barrel was in the custody of the defendant who occupied the premises, and who is responsible for the acts of his servants who had the control of it; and in my opinion the fact of its falling is *prima facie* evidence of negligence, and the plaintiff who was injured by it is not bound to show that it could not fall without negligence, but if there are any facts inconsistent with negligence it is for the defendant to prove them.

Note 1. Why did the plaintiff need help in this case? Why not allow the plaintiff's case to fail? What policy considerations drive the doctrine, in your view?

Note 2. One common fact pattern in RIL cases is objects falling from the sky onto plaintiffs' heads. And yes, it's tort law: there are indeed whole classes of fact patterns like this. In fact, a non-trivial

the shoulder. In the opinion of Dr. Clark, plaintiff's condition was due to trauma or injury by pressure or strain, applied between his right shoulder and neck.

Plaintiff was also examined by Dr. Fernando Garduno, who expressed the opinion that plaintiff's injury was a paralysis of traumatic origin, not arising from pathological causes, and not systemic, and that the injury resulted in atrophy, loss of use and restriction of motion of the right arm and shoulder.

Plaintiff's theory is that the foregoing evidence presents a proper case for the application of the doctrine of *res ipsa loquitur*, and that the inference of negligence arising therefrom makes the granting of a nonsuit improper. Defendants' [***] main defense may be briefly stated in two propositions: (1) that where there are several defendants, and there is a division of responsibility in the use of an instrumentality causing the injury, and the injury might have resulted from the separate act of either one of two or more persons, the rule of *res ipsa loquitur* cannot be invoked against any one of them; and (2) that where there are several instrumentalities, and no showing is made as to which caused the injury or as to the particular defendant in control of it, the doctrine cannot apply. We are satisfied, however, that these objections are not well taken in the circumstances of this case.

The doctrine of *res ipsa loquitur* has three conditions: "(1) the accident must be of a kind which ordinarily does not occur in the absence of someone's negligence; (2) it must be caused by an agency or instrumentality within the exclusive control of the defendant; (3) it must not have been due to any voluntary action or contribution on the part of the plaintiff." [c] is applied in a wide variety of situations, including cases of medical or dental treatment and hospital care. [cc]

There is, however, some uncertainty as to the extent to which *res ipsa loquitur* may be invoked in cases of injury from medical treatment. This is in part due to the tendency, in some decisions, to lay undue emphasis on the limitations of the doctrine, and to give too little attention to its basic underlying purpose. The result has been that a simple, understandable rule of circumstantial evidence, with a sound background of common sense and human experience, has occasionally been transformed into a rigid legal formula, which *490 arbitrarily precludes its application in many cases where it is most important that it should be applied. If the doctrine is to continue to serve a useful purpose, we should not forget that "the particular force and justice of the rule, regarded as a presumption throwing upon the party charged the duty of producing evidence, consists in the circumstance that the chief evidence of the true cause, whether culpable or innocent, is practically accessible to him but inaccessible to the injured person." [cc] *Maki v. Murray Hospital*, 91 Mont. 251 [7 P.2d 228, 231].) In the last-named case, where an unconscious patient in a hospital received injuries from a fall, the court declared that without the doctrine the maxim that for every wrong there is a remedy would be rendered nugatory, "by denying one, patently entitled to damages, satisfaction merely because he is ignorant of facts peculiarly within the knowledge of the party who should, in all justice, pay them."

The present case is of a type which comes within the reason and spirit of the doctrine more fully perhaps than any other. The passenger sitting awake in a railroad car at the time of a collision, the pedestrian walking along the street and struck by a falling object or the debris of an explosion, are surely not more entitled to an explanation than the unconscious patient on the operating table.

Viewed from this aspect, it is difficult to see how the doctrine can, with any justification, be so restricted in its statement as to become inapplicable to a patient who submits himself to the care and custody of doctors and nurses, is rendered unconscious, and receives some injury from instrumentalities used in his treatment. Without the aid of the doctrine a patient who received

permanent injuries of a serious character, obviously the result of someone's negligence, would be entirely unable to recover unless the doctors and nurses in attendance voluntarily chose to disclose the identity of the negligent person and the facts establishing liability. [c] If this were the state of the law of negligence, the courts, to avoid gross injustice, would be forced to invoke the principles of absolute liability, irrespective of negligence, in actions by persons suffering injuries *491 during the course of treatment under anesthesia. But we think this juncture has not yet been reached, and that the doctrine of *res ipsa loquitur* is properly applicable to the case before us.

The condition that the injury must not have been due to the plaintiff's voluntary action is of course fully satisfied under the evidence produced herein; and the same is true of the condition that the accident must be one which ordinarily does not occur unless someone was negligent. We have here no problem of negligence in treatment, but of distinct injury to a healthy part of the body not the subject of treatment, nor within the area covered by the operation. The decisions in this state make it clear that such circumstances raise the inference of negligence, and call upon the defendant to explain the unusual result.[c]

The argument of defendants is simply that plaintiff has not shown an injury caused by an instrumentality under a defendant's control, because he has not shown which of the several instrumentalities that he came in contact with while in the hospital caused the injury; and he has not shown that any one defendant or his servants had exclusive control over any particular instrumentality. Defendants assert that some of them were not the employees of other defendants, that some did not stand in any permanent relationship from which liability in tort would follow, and that in view of the nature of the injury, the number of defendants and the different functions performed by each, they could not all be liable for the wrong, if any.

We have no doubt that in a modern hospital a patient is quite likely to come under the care of a number of persons in different types of contractual and other relationships with each other. For example, in the present case it appears that Doctors Smith, Spangard and Tilley were physicians or surgeons commonly placed in the legal category of independent contractors; and Dr. Reser, the anesthetist, and defendant Thompson, the special nurse, were employees of Dr. Swift and not of the other doctors. But we do not believe that either the number or relationship of the defendants alone determines whether the doctrine of *res ipsa loquitur* applies. Every defendant in whose custody the plaintiff was placed for any period was bound to exercise ordinary care to see that no unnecessary harm came to him and each would be liable for *492 failure in this regard. Any defendant who negligently injured him, and any defendant charged with his care who so neglected him as to allow injury to occur, would be liable. The defendant employers would be liable for the neglect of their employees; and the doctor in charge of the operation would be liable for the negligence of those who became his temporary servants for the purpose of assisting in the operation.

In this connection, it should be noted that while the assisting physicians and nurses may be employed by the hospital, or engaged by the patient, they normally become the temporary servants or agents of the surgeon in charge while the operation is in progress, and liability may be imposed upon him for their negligent acts under the doctrine of *respondeat superior*. Thus a surgeon has been held liable for the negligence of an assisting nurse who leaves a sponge or other object inside a patient, and the fact that the duty of seeing that such mistakes do not occur is delegated to others does not absolve the doctor from responsibility for their negligence. [cc]

It may appear at the trial that, consistent with the principles outlined above, one or more defendants will be found liable and others absolved, but this should not preclude the application of the rule of *res ipsa loquitur*. The control, at one time or another, of one or more of the various agencies or instrumentalities which might have harmed the plaintiff was in the hands of every defendant or of his employees or temporary servants. This, we think, places upon them the burden of initial explanation. Plaintiff was rendered unconscious for the purpose of undergoing surgical treatment by the defendants; it is manifestly unreasonable for them to insist that he identify any one of them as the person who did the alleged negligent act.

The other aspect of the case which defendants so strongly emphasize is that plaintiff has not identified the instrumentality any more than he has the particular guilty defendant. Here, again, there is a misconception which, if carried to the extreme for which defendants contend, would unreasonably limit the application of the *res ipsa loquitur* rule. It should be enough that the plaintiff can show an injury resulting *493 from an external force applied while he lay unconscious in the hospital; this is as clear a case of identification of the instrumentality as the plaintiff may ever be able to make.

An examination of the recent cases, particularly in this state, discloses that the test of actual exclusive control of an instrumentality has not been strictly followed, but exceptions have been recognized where the purpose of the doctrine of *res ipsa loquitur* would otherwise be defeated. Thus, the test has become one of right of control rather than actual control. See *Metx v. Southern Pac. Co.*, 51 Cal.App.2d 260, 268). In the bursting bottle cases where the bottler has delivered the instrumentality to a retailer and thus has given up actual control, he will nevertheless be subject to the doctrine where it is shown that no change in the condition of the bottle occurred after it left the bottler's possession, and it can accordingly be said that he was in constructive control. (*Escola v. Coca Cola Bottling Co.*, 24 Cal.2d 453). Moreover, this court departed from the single instrumentality theory in the colliding vehicle cases, where two defendants were involved, each in control of a separate vehicle. [cc] Finally, it has been suggested that the hospital cases may properly be considered exceptional, and that the doctrine of *res ipsa loquitur* "should apply with equal force in cases wherein medical and nursing staffs take the place of machinery and may, through carelessness or lack of skill, inflict, or permit the infliction of, injury upon a patient who is thereafter in no position to say how he received his injuries." (*Maki v. Murray Hospital*, 91 Mont. 251; see, also, *Whetstine v. Moravec*, 228 Iowa 352, where the court refers to the "instrumentalities" as including "the unconscious body of the plaintiff.")

In the face of these examples of liberalization of the tests for *res ipsa loquitur*, there can be no justification for the rejection of the doctrine in the instant case. As pointed out above, if we accept the contention of defendants herein, there will rarely be any compensation for patients injured while unconscious. A hospital today conducts a highly integrated system of activities, with many persons contributing their efforts. There may be, e.g., preparation for surgery by nurses *494 and internes who are employees of the hospital; administering of an anesthetic by a doctor who may be an employee of the hospital, an employee of the operating surgeon, or an independent contractor; performance of an operation by a surgeon and assistants who may be his employees, employees of the hospital, or independent contractors; and post surgical care by the surgeon, a hospital physician, and nurses. The number of those in whose care the patient is placed is not a good reason for denying him all reasonable opportunity to recover for negligent harm. It is rather a good reason for re-examination of the statement of legal theories which supposedly compel such a shocking result.

We do not at this time undertake to state the extent to which the reasoning of this case may be applied to other situations in which the doctrine of *res ipsa loquitur* is invoked. We merely hold that where a plaintiff receives unusual injuries while unconscious and in the course of medical treatment, all those defendants who had any control over his body or the instrumentalities which might have caused the injuries may properly be called upon to meet the inference of negligence by giving an explanation of their conduct.

The judgment is reversed.

Note 1. The court expresses concern that “a patient who received permanent injuries of a serious character, obviously the result of someone’s negligence, would be entirely unable to recover unless the doctors and nurses in attendance voluntarily chose to disclose the identity of the negligent person and the facts establishing liability.” If parties can be compelled to testify under oath at trial, why would the court be worried?

Note 2. How far should the rule of *Ybarra v. Spangard* extend, in your view? Does it seem equally fair to apply it in different kinds of contexts or does it gain greater legitimacy in the context of medical care?

Note 3. How important is the “instrumentality” to the operation of RIL? If it is unknown, can RIL be deployed nonetheless? If it is known, is RIL truly necessary?

Note 4. What is the significance of the court’s reference to the operations of a “modern hospital”?

Chapter 19. Negligence: Causation

Causation in Fact versus Proximate Cause. There are two distinct inquiries to satisfy the causation element for negligence. The first, “**cause in fact**,” poses a factual causation (did this thing *cause* that injury) and the second, “**proximate cause**,” poses a policy question (given that this thing *did cause* that injury, *should* the law limit or find liability in this case?) The first question is descriptive; the second question is normative. Proximate cause functions somewhat like duty in that both can operate as liability-limiting principles except that duty is a question of law determined by the judge and often used as a gatekeeping mechanism; proximate cause is a question of fact decided by the jury and thus usually requires development of a fuller factual record. Both causation and proximate cause are questions of fact determined by the jury. One might reasonably ask why cause in fact would be a jury question given that it can sometimes involve intensely complicated fact patterns. The plaintiff may have to describe complex manufacturing processes or be able to trace harm back to exposure to chemicals, for example, thus requiring the jury to ascertain the existence of some sort of careless mistake and the likelihood that it caused the plaintiff’s injury. One might also reasonably ask why proximate cause would be a jury question given that it requires a clear policy determination and judges seem likelier to be versed in making policy determinations. We will return to this question below when we discuss proximate cause in the next chapter. This introductory discussion deliberately defers the greater complexities associated with causation, such as when there are multiple sufficient causes or when causes may combine to create concurrent consequences. The initial focus here is on the most foundational understanding of causation in fact.

Causation in fact is often described using a counterfactual inquiry that begins with the defendant’s breach of conduct, whatever it constituted. Was that breach the “*sine qua non*” (Latin for the thing “without which, there would be none”)? That is, if we subtracted the defendant’s unreasonable conduct from the facts of the case and the harm would not have happened, then causation in fact is met. If the breach of due care, when removed, makes no difference to the plaintiff’s injuries, causation in fact is typically not met. In some cases a different test may be required because of multiple tortfeasors or causes. But this initial test of “but-for causation” is the primary means of satisfying the first prong of the causation element.

Questions or Areas of Focus for the Readings

- Causation in fact is a factual question for the jury. As you read cases of varying kinds and complexity, do they seem applicable amenable to jury decision making?
- If certain kinds of harm make causation harder, more expensive, or impossible to prove, what mechanisms or outcomes seem appropriate to adopt?
- Causation in fact is distinguished from proximate cause in that the former inquiry is “factual” and the latter is normative, based on policy considerations, as you will learn in a subsequent set of readings. However, the distinction between them suggests that causation in fact possesses fewer policy issues. Consider whether the causation element seems distinguishable from tort law’s more explicitly policy-driven questions.

**Garrison v. Deschutes Cty., Supreme Court of Oregon (2002)
(334 Or. 264) (Facts excerpted from trial and appellate opinions)**

[***] “Gary Garrison was severely injured in a fall at the Fryrear transfer station, which is owned and operated by Deschutes County. The transfer station was designed and built using ‘Z-wall construction’, which consists of a concrete upper slab with a 14.5-foot retaining wall that drops to a concrete lower slab. The design allows persons using the transfer station to back their vehicles onto the upper slab and dump their garbage into semi-truck trailers that have been placed on the lower slab. There is a seven-inch railroad tie at the edge of the upper slab that serves as a barrier to warn drivers not to back their vehicles any further. At the time of Garrison’s fall, there were no other barriers or fences on the upper slab, and there were no signs warning users of the danger of falling from the upper to the lower one.

On the day that Garrison was injured, he and his wife had driven to the transfer station in their pickup with a load of refuse. Both had been to the transfer station before and, as at those earlier times, Garrison backed the pickup up to the railroad tie barrier and lowered the tailgate. When the tailgate was lowered, it protruded out over the edge of the upper slab. Both Garrison and his wife were aware of the distance of the drop from the upper to the lower slab and had discussed the importance of being careful so as not to fall. Garrison stood in the back of the pickup and threw the refuse over the edge and into the trailer below. When he was finished, he grabbed a lumber rail on *268 the back of the pickup and attempted to swing out onto the pavement of the upper slab. In doing so, he fell to the pavement of the lower slab, suffering severe injuries to his face, head, arms and chest.” 162 Or. App. at 162-63.

Plaintiffs’ amended complaint alleged that the county was negligent “[i]n failing to maintain a premises which is reasonably safe from dangers which were known or, in the exercise of reasonable care, should have been known to defendant by placing fences, barriers, or other protective devices next to the wall to prevent individuals from falling,” and “[i]n failing to protect invitees from unreasonably dangerous conditions on the premises which were known to the defendant or, in the exercise of reasonable care, should have been known to the defendant by posting signs or other warning devices warning of the immediate drop off.” [***]

[P]laintiffs contended that the county had a duty to warn of any known dangerous condition on its land and had failed to do so. [***]

The trial court [***] rejected plaintiffs’ failure-to-warn claim, based on what the court termed a “lack of causation.” The court observed that the danger was open and obvious and, in light of plaintiffs’ deposition testimony that they were well aware of the risk, the failure to warn did not expose them to any greater risk of harm than would have been present had they been warned. Accordingly, the court concluded that there was no genuine issue of fact or evidence in the record from which a reasonable juror could have found that there was a causal link of any kind between the failure to warn and the accident that befell Garrison [***] [T]he Court of Appeals agreed that the danger was an obvious one, that plaintiffs were fully aware of the danger, and, consequently, that the absence of a warning did not expose plaintiffs to any greater risk of harm than if they had been warned.

Plaintiffs' first and third specifications of negligence, concerning the county's allegedly negligent design of the transfer station,¹⁰⁵ invoke the general common-law responsibility of all persons to avoid conduct that creates a specific *272 risk of injury to others, as well as the special duties that a possessor of land owes to business invitees. In similar cases involving private landowners and occupiers, this court typically begins by examining the claims to determine whether the property owner's alleged conduct was unreasonable in the circumstances and created a foreseeable, unreasonable risk of harm to the plaintiff. [c] A private landowner or occupier of land in a position similar to the county's would be required to take care to protect patrons on the premises from injuries resulting from known, dangerous conditions on the premises or, at least, to warn them of the danger. *Woolston v. Wells*, 297 Or. 548, 557-58 (1984). [***]

Plaintiffs argue that *Woolston* stands for the proposition that even obvious hazards must be considered within a scheme of comparative fault. The court there stated:

“Each party is held to the same standard of care with respect to common law negligence. Negligence is conduct falling below the standard established for the protection of others, or oneself, against unreasonable risk of harm. The standard of care is measured by what a reasonable person of ordinary prudence would, or would not, do in the same or similar circumstances.” * * *

In general, it is the duty of the possessor of land to make the premises reasonably safe for the invitee's visit. The possessor must exercise the standard of care above stated to discover conditions of the premises that create an unreasonable risk of harm to the invitee. The possessor must exercise that standard of care either to eliminate the condition creating that risk or to warn any foreseeable invitee of the risk so as to enable the invitee to avoid the harm. The invitee is required to exercise that same standard of care in avoiding harm from a condition of the premises of which he knows, or, in the exercise of that standard of care, of which he should know. *279

Instructions to the jury should be framed in terms of that standard of care. The jury will thereby be enabled to determine whether any given party is at fault and if both are at fault to compare that fault as the statute commands. In determining and comparing fault, the jury must necessarily consider the obviousness of danger and the ease or difficulty with which harm to the plaintiff from that danger could be avoided by either party.” 297 Or. at 557-58, (citation omitted).

Plaintiffs contend that the Court of Appeals' holding is inconsistent with the foregoing directive. They assert that the Court of Appeals effectively held, *as a matter of law*, that there is no “causal link” when the invitee confronts a known or obvious danger. [***]

Plaintiffs misunderstand the Court of Appeals' holding. The Court of Appeals concluded that, *on the undisputed evidence in this case*, there was no causal link between the county's failure to warn and the

¹⁰⁵ As noted, plaintiffs' first specification does not allege negligence in the design of the refuse transfer station. Instead, the specification charges negligence in “failing to maintain” a facility with barriers to protect patrons from falling over the edge of the platform. We agree with the county, however, that the gravamen of that allegation is that the county's alleged failure to design the platform in a way that included protective barriers (other than the railroad tie that prevented vehicles from backing up too far) made the platform unreasonably dangerous.

injuries that befell plaintiffs. That conclusion is well supported by the evidence that plaintiffs were fully aware of the danger presented by the drop-off and the lack of a barrier at the edge of the platform.

In the present case, the evidence on summary judgment establishes that the county's failure to warn did not expose plaintiffs to any greater risk of harm than if they had been warned. Plaintiffs testified at length at their depositions that they had used the transfer station before, that they knew of and always had been concerned about the drop-off and the lack of a protective barrier at the edge of the platform, and that they had discussed the importance of being careful not to fall. Given that testimony, no reasonable juror could find that a warning would have made a difference. The Court of Appeals was correct in so holding.

The decision of the Court of Appeals and the judgment of the circuit court are affirmed.

Note 1. This case also featured two additional important issues: first, the question of the government's qualified immunity from suit here (to which Module 4 returns, using this same case), and second, the question of whether the transfer station was negligently designed. Can you see the significance of those questions looming in the background, in addition to this more straightforward doctrinal issue of causation?

Note 2. What was the act or acts that constituted a potential breach of duty here? Why did this not matter? Did the court's reasoning rest on the plaintiff's conduct or the defendant's (or both)?

Note 3. If the plaintiff had been clearly negligent in his conduct, how might the analysis need to shift? When "but-for causation" fails because of multiple sources of negligent conduct, many courts apply the **substantial factor** test in which they ask whether the unreasonable conduct was a substantial factor in the ultimate harm. This test has been critiqued because of its malleability since "substantial," like "reasonable" is a standard that lacks a fixed meaning. However but it can be useful when the causal nexus is complicated.

Challenges for Causation Analysis

It is not uncommon in accidents caused by allegedly tortious conduct to find that multiple factors played a role in causing the harm. In some instances, as you will see in the cases throughout this section, it can be proven that either one or another factor (or party) caused the harm but it may remain difficult for the plaintiff to determine which of the two alternate possible tortfeasors was the actual tortfeasor. Such a scenario invites the application of **alternate liability**, as in *Summers v. Tice*. However, even more commonly, there are more than two parties or factors potentially to blame. If the factors *must have combined* to cause the harm, then under **concurrent liability** it may be that all are blameworthy whether or not they are all reachable through a lawsuit. (Sometimes, one party is immune or judgment proof or unavailable for some other reason.) **Joint and several liability** may also apply in some cases.

Under joint and several liability, any of the tortfeasors may be individually liable for the amount they alone caused or for the amount of harm caused by the whole group, either because the actors were acting **in concert** (on some sort of outing or joint venture perhaps) or because they caused harm that is effectively indivisible. These are problems of liability—who *caused* the harm—but also problems of allocation—who should *pay for the harm* regardless of who actually caused it. In some rare

instances, there are numerous separate entities causing wrongdoing and sometimes it is not clear which tortfeasor caused the specific harm suffered by a particular plaintiff. In concert liability fails because the entities are not connected; joint liability fails for the same reason. Alternate liability would also fail because there are more than two. In response to a case of widespread harm in the form of birth defects caused by a drug ingested by pregnant women, the California Supreme Court applied a new doctrine, **market share liability**, which allows a plaintiff who suffers from some defective product to pursue a manufacturer of the product even if it's unclear whether *that manufacturer* or another one caused their harm. There are particular limits as different courts have adopted the doctrine and it is extremely rare for courts to apply it for reasons explained in a later case. In *Smith v. Cutter Biological* 72 Haw. 416 (1991), the court declined to adopt either alternate liability or joint liability when the hemophiliac recipient of a blood transfusion contracted AIDS from the procedure, but the court found that the plaintiff could recover under market share liability.

Alternate Liability

Summers v. Tice, Supreme Court of California, in Bank [sic] (1948) (33 Cal.2d 80)

Each of the two defendants appeals from a judgment against them in an action for personal injuries. Pursuant to stipulation the appeals have been consolidated. Plaintiff's action was against both defendants for an injury to his right eye and face as the result of being struck by bird shot discharged from a shotgun. The case was tried by the court without a jury and the court found that on November 20, 1945, plaintiff and the two defendants were hunting quail on the open range. Each of the defendants was armed with a 12 gauge shotgun loaded with shells containing 7 1/2 size shot. Prior to going hunting plaintiff discussed the hunting procedure with defendants, indicating that they were to exercise care when shooting and to 'keep in line.' In the course of hunting plaintiff proceeded up a hill, thus placing the hunters at the points of a triangle. The view of defendants with reference to plaintiff was unobstructed and they knew his location. Defendant Tice flushed a quail which rose in flight to a ten foot elevation and flew between plaintiff and defendants. Both defendants shot at the quail, shooting in plaintiff's direction. At that time defendants were 75 yards from plaintiff. One shot struck plaintiff in his eye and another in his upper lip. Finally it was found by the court that as *83 the direct result of the shooting by defendants the shots struck plaintiff as above mentioned and that defendants were negligent in so shooting and plaintiff was not contributorily negligent.

First, on the subject of negligence, defendant Simonson contends that the evidence is insufficient to sustain the finding on that score, but he does not point out wherein it is lacking. There is evidence that both defendants, at about the same time or one immediately after the other, shot at a quail and in so doing shot toward plaintiff who was uphill from them, and that they knew his location. That is sufficient from which the trial court could conclude that they acted with respect to plaintiff other than as persons of ordinary prudence. The issue was one of fact for the trial court. [c]

Defendant Tice states in his opening brief, 'we have decided not to argue the insufficiency of negligence on the part of defendant Tice.' It is true he states in his answer to plaintiff's petition for a

hearing in this court that he did not concede this point but he does not argue it. Nothing more need be said on the subject.

Defendant Simonson urges that plaintiff was guilty of contributory negligence and assumed the risk as a matter of law. He cites no authority for the proposition that by going on a hunting party the various hunters assume the risk of negligence on the part of their companions. Such a tenet is not reasonable. It is true that plaintiff suggested that they all 'stay in line,' presumably abreast, while hunting, and he went uphill at somewhat of a right angle to the hunting line, but he also cautioned that they use care, and defendants knew plaintiff's position. We hold, therefore, that the trial court was justified in finding that he did not assume the risk or act other than as a person of ordinary prudence under the circumstances. [***] None of the cases cited by Simonson are in point.

The problem presented in this case is whether the judgment against both defendants may stand. It is argued by defendants that they are not joint tortfeasors, and thus jointly and severally liable, as they were not acting in concert, and that there is not sufficient evidence to show which defendant was guilty of the negligence which caused the injuries the shooting by Tice or that by Simonson. Tice argues that there is *84 evidence to show that the shot which struck plaintiff came from Simonson's gun because of admissions allegedly made by him to third persons and no evidence that they came from his gun. Further in connection with the latter contention, the court failed to find on plaintiff's allegation in his complaint that he did not know which one was at fault did not find which defendant was guilty of the negligence which caused the injuries to plaintiff.

Considering the last argument first, we believe it is clear that the court sufficiently found on the issue that defendants were jointly liable and that thus the negligence of both was the cause of the injury or to that legal effect. It found that both defendants were negligent and 'That as a direct and proximate result of the shots fired by defendants, and each of them, a birdshot pellet was caused to and did lodge in plaintiff's right eye and that another birdshot pellet was caused to and did lodge in plaintiff's upper lip.' In so doing the court evidently did not give credence to the admissions of Simonson to third persons that he fired the shots, which it was justified in doing. It thus determined that the negligence of both defendants was the legal cause of the injury or that both were responsible. Implicit in such finding is the assumption that the court was unable to ascertain whether the shots were from the gun of one defendant or the other or one shot from each of them. The one shot that entered plaintiff's eye was the major factor in assessing damages and that shot could not have come from the gun of both defendants. It was from one or the other only.

It has been held that where a group of persons are on a hunting party, or otherwise engaged in the use of firearms, and two of them are negligent in firing in the direction of a third person who is injured thereby, both of those so firing are liable for the injury suffered by the third person, although the negligence of only one of them could have caused the injury. ...These cases speak of the action of defendants as being in concert as the ground *85 of decision, yet it would seem they are straining that concept and the more reasonable basis appears in *Oliver v. Miles*, supra. There two persons were hunting together. Both shot at some partridges and in so doing shot across the highway injuring plaintiff who was travelling on it. The court stated they were acting in concert and thus both were liable. The court then stated (110 So. 668): 'We think that * * * each is liable for the resulting injury to the boy, although no one can say definitely who actually shot him. *To hold otherwise would be to exonerate both from liability, although each was negligent, and the injury resulted from such negligence.*' (Emphasis added.) 110 So. p. 668.

It is said in the Restatement: 'For harm resulting to a third person from the tortious conduct of another, a person is liable if he * * * (b) knows that the other's conduct constitutes a breach of duty and gives substantial assistance or encouragement to the other so to conduct himself, or (c) gives substantial assistance to the other in accomplishing a tortious result and his own conduct, separately considered, constitutes a breach of duty to the third person.' (Rest., Torts, sec. 876(b)(c).) Under subsection (b) the example is given: 'A and B are members of a hunting party. Each of them in the presence of the other shoots across a public road at an animal this being negligent as to persons on the road. A hits the animal. B's bullet strikes C, a traveler on the road. A is liable to C.' (Rest., Torts, Sec. 876(b), Com., Illus. 3.) An illustration given under subsection (c) is the same as above except the factor of both defendants shooting is missing and joint liability is not imposed. It is further said that: 'If two forces are actively operating, one because of the actor's negligence, the other not because of any misconduct on his part, and each of itself sufficient to bring about harm to another, the actor's negligence may be held by the jury to be a substantial factor in bringing it about.' (Rest., Torts, sec. 432.)

Dean Wigmore has this to say: 'When two or more persons by their acts are possibly the sole cause of a harm, or when two or more acts of the same person are possibly the sole cause, and the plaintiff has introduced evidence that the one of the two persons, or the one of the same person's two acts, is culpable, then the defendant has the burden of proving that the other person, or his other act, was the sole cause of the harm. (b) * * * The real reason for the rule that each joint tortfeasor is responsible for the whole damage is the practical unfairness of denying the injured person redress simply because he cannot prove how *86 much damage each did, when it is certain that between them they did all; let them be the ones to apportion it among themselves. Since, then, the difficulty of proof is the reason, the rule should apply whenever the harm has plural causes, and not merely when they acted in conscious concert. * * * ' (Wigmore, Select Cases on the Law of Torts, sec. 153.) Similarly Professor Carpenter has said: '(Suppose) the case where A and B independently shoot at C and but one bullet touches C's body. In such case, such proof as is ordinarily required that either A or B shot C, of course fails. It is suggested that there should be a relaxation of the proof required of the plaintiff * * * where the injury occurs as the result of one where more than one independent force is operating, and it is impossible to determine that the force set in operation by defendant did not in fact constitute a cause of the damage, and where it may have caused the damage, but the plaintiff is unable to establish that it was a cause.' (20 Cal.L. Rev. 406.)

When we consider the relative position of the parties and the results that would flow if plaintiff was required to pin the injury on one of the defendants only, a requirement that the burden of proof on that subject be shifted to defendants becomes manifest. They are both wrongdoers both negligent toward plaintiff. They brought about a situation where the negligence of one of them injured the plaintiff, hence it should rest with them each to absolve himself if he can. The injured party has been placed by defendants in the unfair position of pointing to which defendant caused the harm. If one can escape the other may also and plaintiff is remediless. Ordinarily defendants are in a far better position to offer evidence to determine which one caused the injury. This reasoning has recently found favor in this Court. In a quite analogous situation this Court held that a patient injured while unconscious on an operating table in a hospital could hold all or any of the persons who had any connection with the operation even though he could not select the particular acts by the particular person which led to his disability. *Ybarra v. Spangard*, 25 Cal.2d 486. There the Court was considering whether the patient could avail himself of *res ipsa loquitur*, rather than where the burden of proof lay, yet the effect of the decision is that plaintiff has made out a case when he has produced evidence which gives rise to an

inference of negligence which was the proximate cause of the injury. It is up to *87 defendants to explain the cause of the injury. It was there said: ‘If the doctrine is to continue to serve a useful purpose, we should not forget that ‘the particular force and justice of the rule, regarded as a presumption throwing upon the party charged the duty of producing evidence, consists in the circumstance that the chief evidence of the true cause, whether culpable or innocent, is practically accessible to him but inaccessible to the injured person.’ 25 Cal.2d at page 490. Similarly in the instant case plaintiff is not able to establish which of defendants caused his injury. [***]

Cases are cited for the proposition that where two or more tortfeasors acting independently of each other cause an injury to plaintiff, they are not joint tortfeasors and plaintiff must establish the portion of the damage caused by each, even though it is impossible to prove the portion of the injury caused by each. [cc] In view of the foregoing discussion it is apparent that defendants in cases like the present one may be treated as liable on the same basis as joint tortfeasors, and hence the last cited cases are distinguishable inasmuch as they involve independent tortfeasors.

In addition to that, however, it should be pointed out that the same reasons of policy and justice shift the burden to each of defendants to absolve himself if he can relieving the wronged person of the duty of apportioning the injury to a particular defendant, apply here where we are concerned with whether plaintiff is required to supply evidence for the apportionment of damages. If defendants are independent tortfeasors and thus each liable for the damage caused by him alone, and, at least, where the matter of apportionment is incapable of proof, the innocent wronged party should not be deprived of his right to redress. The wrongdoers should be left to work out between themselves any apportionment. [c] Some of the cited cases refer to the difficulty of apportioning the burden of damages between the independent tortfeasors, and say that where factually a correct division cannot be made, the trier of fact may make it the best it can, which would be more or less a guess, stressing the factor that the wrongdoers are not a position to complain of uncertainty. [c]

It is urged that plaintiff now has changed the theory of his case in claiming a concert of action; that he did not plead or prove such concert. From what has been said it is clear that there has been no change in theory. The joint liability, as well as the lack of knowledge as to which defendant was liable, was pleaded and the proof developed the case under either theory. We have seen that for the reasons of policy discussed herein, the case is based upon the legal proposition that, under the circumstances here presented, each defendant is liable for the whole damage whether they are deemed to be acting in concert or independently.

The judgment is affirmed.

Note 1. Why does the court not discuss whether the parties breached their duty of due care?

Note 2. *Summers v. Tice* laid down a rule known now as “alternative liability” to cure the problem created when two defendants are found to have breached their duty, but it is unknown which of them *caused* the plaintiff’s harm. Do you follow the court’s discussion of in concert liability? And joint liability? Alternative liability differs from “in concert” liability. Can you identify how it does so? Does alternative liability rule seem fair to you? Why or why not? Does it seem efficient, whether or not it seems fair?

Note 3. The court mentions the problem of “more than one independent force is operating,” which may make it difficult to establish cause and quotes approvingly an article stating that in such cases “there

should be a relaxation of the proof required of the plaintiff.” What does it mean, precisely, to “relax” the proof required? Did *Ybarra v. Spangard, supra* “relax” the proof for the plaintiff? If so, was it in a similar fashion as in *Summers*? If not, how would you characterize the application of RIL in *Ybarra*?

Note 4. If the facts of *Summers* changed to include multiple hunters, would this change your analysis?

Note 5. Multiple Sufficient Acts / Overdetermined Causation. In rare instances, more than one act or factor could independently cause a plaintiff’s injuries. The paradigmatic example is fire. Imagine two defendants separately and negligently cause fires to start on either side of the plaintiff’s home and the home is destroyed. Such a scenario would, under the but-for causation test, produce an unfair result: “But for Defendant 1’s negligent conduct, would the plaintiff’s harm still have occurred?” The answer must be yes, since Defendant 2’s conduct would also have resulted in destroying the home. In some cases, forensic analysis or a timeline can provide clues as to which party was more at fault, but in cases of indivisible harm that is occasionally impossible. It would be unfair to allow *both* parties to escape liability on the grounds that they each could point to the other as *also* being liable. This is different from *Summers v. Tice* in which *one or the other but not both* were liable. Hence a rule evolved to treat both their actions as *a* cause.

The Restatement (Third) of Torts: Phys. & Emot. Harm § 27 (2010) provides: “If multiple acts occur, each of which under § 26 alone would have been a factual cause of the physical harm at the same time in the absence of the other act(s), each act is regarded as a factual cause of the harm.”

Be sure to distinguish a scenario featuring **successive tortfeasors** from a multiple sufficient causes scenario. Imagine Defendant 1’s tortious conduct causes a collision that kills a plaintiff, if a second negligent ambulance driver comes, correctly confirms the plaintiff is dead and then does some additional minor damage to the plaintiff’s body in transporting it to a morgue. The ambulance driver *might* be liable for the additional minor damage to the corpse under a wrongful death statute. But they are a successive tortfeasor if so, not a cause of the plaintiff’s death; that liability falls to Defendant 1.

Negligence: Causation (Issues of Proof)

Zuchowicz v. United States, Court of Appeals for the Second Circuit (1998) (140 F.3d 381)

[***] This suit under the Federal Tort Claims Act, 28 U.S.C. §§ 1346(b), 2671–2680, was originally filed by Patricia Zuchowicz, who claimed to have developed primary pulmonary hypertension, a fatal lung condition, as a result of the defendant’s negligence in prescribing an overdose of the drug Danocrine. Following Mrs. Zuchowicz’s death in 1991, her husband, Steven, continued the case on behalf of his wife’s estate, claiming that the defendant was responsible for her death. After a bench trial, the district court awarded the plaintiff \$1,034,236.02 in damages.

The case statement recited above goes to the heart of the law of torts. A plaintiff claims to have developed a fatal condition as a result of a defendant’s negligence in prescribing an excessive amount of a drug—a tragic injury allegedly caused by defendant’s wrong. There is no doubt in the case before

us either as to the injury or as to the defendant's wrong; both are conceded. The only issue is causation. Did the action for which the defendant is responsible cause, in a legal sense, the harm which the plaintiff suffered?—a question easily put and often very hard to answer. There is, moreover, no older requirement in this area of law than the need to show such a link between the defendant's actions and the plaintiff's loss. It long precedes the obligation to show that the defendant was at fault.¹⁰⁶ Along with the showing of injury, *384 causation constituted an essential part of what the plaintiff had to demonstrate for the early common law action in trespass to lie.¹⁰⁷

Over the centuries the courts have struggled to give meaning to this requirement—in the simplest of situations, who hit whom, [fn] and in the most complex ones, which polluter's emissions, if any, hurt which plaintiff.¹⁰⁸ It is the question that we must seek to answer today in the context of modern medicine and a very rare disease.

II. Background

The facts, as determined by the district court, are as follows. On February 18, 1989, Mrs. Zuchowicz filled a prescription for the drug Danocrine at the Naval Hospital pharmacy in Groton, Connecticut. The prescription erroneously instructed her to take 1600 milligrams of Danocrine per day, or twice the maximum recommended dosage. The defendant has stipulated that its doctors and/or pharmacists were negligent and violated the prevailing standard of medical care by prescribing this wrong dosage. [***] In October 1989, she was diagnosed with primary pulmonary hypertension ("PPH"), a rare and fatal disease in which increased pressure in an individual's pulmonary artery causes severe strain on the right side of the heart. At the time she was diagnosed with the disease, the median life expectancy for PPH sufferers was 2.5 years. [***] PPH is very rare. A National Institute of Health registry recorded only 197 cases of PPH from the mid-1980s until 1992. It occurs predominantly in young women. Exogenous agents known to be capable of causing PPH include birth control pills, some appetite suppressants, chemotherapy drugs, rapeseed oil, and L-Tryptophan. [***]

Danocrine has been extensively studied and prescribed since the late 1960s for endometriosis. According to the testimony of plaintiff's expert Dr. W. Paul D'Mowski, who personally performed much of the initial research on the drug, Danocrine is safe and effective when administered properly. Based on studies by Dr. D'Mowski and others, Danocrine was approved by the Food and Drug Administration ("FDA") for use in dosages not to exceed 800 mg/day. Mrs. Zuchowicz was accidentally given a prescription instructing her to take twice this amount—1600 mg/day. According to Dr. D'Mowski no formal studies of the effects of Danocrine at such high doses have been performed, and very, very few women have received doses this high in any setting.

The rarity of PPH, combined with the fact that so few human beings have ever received such a high dose of Danocrine, obviously impacted on the manner in which the plaintiff could prove causation.

¹⁰⁶ In England the requirement of fault in cases of direct injury to plaintiffs by defendants is generally dated to Baron Bramwell's opinion in *Holmes v. Mather*, 10 Exch. 261 (1875) [c]. In many of the states of the United States the requirement was imposed earlier. The opinion most frequently cited is that of Chief Justice Lemuel Shaw in *Brown v. Kendall*, 60 Mass. (6 Cush.) 292 (1850) [c].

¹⁰⁷ The requirement of causation was a well-recognized and essential element of the plaintiff's case in chief in 17th century trespass actions such as *Weaver v. Ward*, Hobart 134, 80 Eng. Rep. 28 (K.B.1617) [c] and *Gibbons v. Pepper*, 1 Ray. 38, 91 Eng. Rep. 922 (K.B.1695) [c]. The action in trespass, and especially trespass *vi et armis* (along with the later action of trespass on the case), is generally regarded as the ancestor of the modern personal injury suit.

¹⁰⁸ See *Michie v. Great Lakes Steel Div.*, 495 F.2d 213 (6th Cir.1974).

The number of persons who received this type of overdose was simply too small for the plaintiff to be able to provide epidemiological, or even anecdotal, evidence linking PPH to Danocrine overdoses. The plaintiff (Mrs. Zuchowicz's husband and executor), therefore, based his case primarily on the testimony of two expert witnesses, Dr. Richard Matthay, a physician and expert in pulmonary diseases, and Dr. Randall Tackett, a professor of pharmacology who has published widely in the field of the effects of drugs on vascular tissues. In rendering a judgment for the plaintiff, the district court relied heavily on the evidence submitted by these two experts. The defendant challenges both the admissibility and the sufficiency of their testimony.

Dr. Richard Matthay is a full professor of medicine at Yale and Associate Director and Training Director of Yale's Pulmonary and Critical Care Section. He is a nationally recognized expert in the field of pulmonary medicine, with extensive experience in the area of drug-induced pulmonary diseases. Dr. Matthay examined and treated Mrs. Zuchowicz. His examination included taking a detailed history of the progression of her disease, her medical history, and the timing of her Danocrine overdose and the onset of her symptoms. Dr. Matthay testified that he was confident to a reasonable medical certainty that the Danocrine caused Mrs. Zuchowicz's PPH. When pressed, he added that he believed the *overdose* of Danocrine to have been responsible for the disease. His conclusion was based on the temporal relationship between the overdose and the start of the disease and the differential etiology method of excluding other possible causes. While Dr. Matthay did not rule out *all* other possible causes of pulmonary hypertension, he did exclude all the causes of secondary pulmonary hypertension. On the basis of Mrs. Zuchowicz's history, he also ruled out all previously known drug-related causes of primary pulmonary hypertension.

Dr. Matthay further testified that the progression and timing of Mrs. Zuchowicz's disease in relation to her overdose supported a finding of drug-induced PPH. Dr. Matthay emphasized that, prior to the overdose, Mrs. Zuchowicz was a healthy, active young woman with no history of cardiovascular problems, and that, shortly after the overdose, she began experiencing symptoms of PPH such as weight gain, swelling of hands and feet, fatigue, and shortness of breath. He described the similarities between the course of Mrs. Zuchowicz's illness and that of accepted cases of drug-induced PPH, and he went on to discuss cases involving classes of drugs that are known to cause other pulmonary diseases (mainly anti-cancer drugs). He noted that the onset of these diseases, which are recognized to be caused by the particular drugs, was very similar in timing *386 and course to the development of Mrs. Zuchowicz's illness.

Dr. Randall Tackett is a tenured, full professor of pharmacology and former department chair from the University of Georgia. He has published widely in the field of the effects of drugs on vascular tissues. Dr. Tackett testified that, to a reasonable degree of scientific certainty, he believed that the overdose of Danocrine, more likely than not, caused PPH in the plaintiff by producing: 1) a decrease in estrogen; 2) hyperinsulinemia, in which abnormally high levels of insulin circulate in the body; and 3) increases in free testosterone and progesterone. Dr. Tackett testified that these hormonal factors, taken together, likely caused a dysfunction of the endothelium leading to PPH. Dr. Tackett relied on a variety of published and unpublished studies that indicated that these hormones could cause endothelial dysfunction and an imbalance of vasoconstrictor effects.

II. Discussion

A. Was the Admission of the Plaintiff's Experts' Testimony Manifestly Erroneous?

The defendant's first argument is that the district court erred in admitting the testimony of Dr. Tackett and Dr. Matthay. We review the district court's decision to admit or exclude expert testimony under a highly deferential abuse of discretion standard. [c] The Federal Rules of Evidence permit opinion testimony by experts when the witness is "qualified as an expert by knowledge, skill, experience, training, or education," and "[i]f scientific, technical, or other specialized knowledge will assist the trier of fact to understand the evidence or to determine a fact in issue." Fed.R.Evid. 702. And though in *Daubert v. Merrell Dow Pharmaceuticals, Inc.*, 509 U.S. 579, 588–89, (1993), the Supreme Court altered the traditional test for the admissibility of expert testimony, it did not change the standard of appellate review of these decisions [c].¹⁰⁹

Under *Daubert*, trial judges are charged with ensuring that expert testimony "both rests on a reliable foundation and is relevant to the task at hand." 509 U.S. at 597. Thus, while *Daubert* and the Federal Rules of Evidence "allow district courts to admit a somewhat broader range of scientific testimony than would have been admissible under *Frye*, they leave in place the 'gatekeeper' role of the trial judge in screening such evidence." [c] Indeed *Daubert* strengthens this role, for it requires that judges make a "preliminary assessment of whether the reasoning or methodology underlying the testimony is scientifically valid and of whether that reasoning or methodology properly can be applied to the facts in issue." 509 U.S. at 592–93.

The factors identified by the Supreme Court as relevant to this inquiry are: (1) whether the theory can be (and has been) tested according to the scientific method; (2) whether the theory or technique has been subjected to peer review and publication; (3) in the case of a particular scientific technique, the known or potential rate of error; and (4) whether the theory is generally accepted. *See id.* at 593–94. The Court emphasized, however, that these factors were not an exclusive or dispositive list of what should be considered, and *387 that the trial court's inquiry should be a "flexible one." *Id.* at 594.

The question in this case is whether, in light of these factors, the district court's decision to admit the testimony of Dr. Matthay and Dr. Tackett was an abuse of discretion. [***] In the case before us [***] the district court carefully undertook and fulfilled its role in making the evaluation required by *Daubert*—a "preliminary assessment of whether the reasoning or methodology underlying the testimony is scientifically valid and of whether that reasoning or methodology properly can be applied to the facts in issue." 509 U.S. at 592–93. Where, as in this case, the district court decides to admit the testimony of well-credentialed experts relying on scientific methodology, we should and will be reluctant to upset that decision as an abuse of discretion.

In the district court, the defendant made substantially the same arguments, regarding the validity of the methods used by Dr. Matthay and Dr. Tackett in reaching their conclusions, that it now raises on appeal. The district court rejected these arguments, stating that the plaintiff's experts "based their opinions on methods reasonably relied on by experts in their particular fields." We do not believe that the district court's decision in this regard was erroneous, let alone manifestly so.

B. Were the District Court's Factual Findings with Respect to Causation Clearly Erroneous?

¹⁰⁹ In *Daubert*, the Supreme Court rejected the traditional *Frye* rule (which had required that a scientific theory be generally accepted by the scientific community to be admissible, *see Frye v. United States*, 293 F. 1013, 1014 (D.C.Cir.1923)), concluding that adherence to *Frye*'s "rigid 'general acceptance' requirement would be at odds with the 'liberal thrust' of the Federal Rules [of Evidence]." *Daubert*, 509 U.S. at 588 (citations omitted).

We review the district court's factual findings for clear error. [c] The defendant argues that, even assuming that the testimony of the plaintiff's experts was admissible, the district court's finding that the Danocrine overdose more likely than not caused Mrs. Zuchowicz's illness was clearly erroneous. The defendant contends that, since Danocrine has never been previously linked to PPH, the district court's conclusion that the drug caused Mrs. Zuchowicz's illness was impermissible. For the reasons stated below, we reject the defendant's arguments.

The liability of the federal government under the Federal Tort Claims Act is determined according to the law of the state in which the injury occurred. *See* 28 U.S.C. § 1346(b); [c] Connecticut law, therefore, provides the applicable standards in this case. A plaintiff alleging medical malpractice in Connecticut must first prove that the defendant negligently deviated from the customary standard of care. [c] Since the defendant has stipulated that its agents were negligent in prescribing an overdose of the drug Danocrine, there is no question that this requirement is satisfied. In addition, "the plaintiff must establish a causal relationship between the physician's negligent actions or failure to act and the resulting injury by showing that the action or omission constituted a substantial factor in *388 producing the injury." [cc] This "substantial factor" causation requirement is the crux of the case before us.

To meet the requirement that defendant's behavior was a substantial factor in bringing about the plaintiff's injury, the plaintiff must generally show: (a) that the defendant's negligent act or omission was a *but for* cause of the injury,¹¹⁰ (b) that the negligence was causally linked to the harm, [fn] and (c) that the defendant's negligent act or omission was proximate to the resulting injury. *389 [fn] [***]

In the case before us, as we shall see, neither the requirement of proximity nor that of causal link gives rise to any problems (though the presence of a strong causal link will prove to be highly significant). The case turns only on the difficulty of showing a *but for* cause. On whether, in other words, the plaintiff has sufficiently demonstrated: (a) that defendant's act in giving Mrs. Zuchowicz Danocrine

¹¹⁰ In non-negligence cases, the same requirement applies as to those non-faulty acts or activities (*e.g.*, product defects, extra-hazardous behavior) on whose existence the potential liability is grounded. In the last fifty years the strictness of the requirement that the plaintiff show that without defendant's act or omission the accident would not have occurred has been mitigated in several types of cases. For instance, where two defendants are both clearly at fault, where the plaintiff has little or no information as to which one's negligence was responsible for the injury, and especially where the defendants may have better access to such information, the modern trend is to place the burden on the defendants to disprove causation. *See, e.g.*, *Summers v. Tice*, 33 Cal.2d 80 (1948); *see also*, *Modave v. Long Island Jewish Med. Ctr.*, 501 F.2d 1065 (2d Cir. 1974) (Friendly, J.) (suggesting that, under New York law, a plaintiff may not need to prove which of two culpable defendants actually caused the plaintiff's injury even when the defendants were probably no more able to show what happened than was the plaintiff). Another important example of this easing trend has been the acceptance of statistical or market share evidence as a means of assigning at least part of a loss to various defendants whose conduct justified liability but who could not be identified, more probably than not, as having been *but for* causes of it. *See, e.g.*, *Sindell v. Abbott Labs.*, 26 Cal.3d 588 (1980); *Hymowitz v. Eli Lilly & Co.*, 73 N.Y.2d 487 (1989). Many courts long ago abandoned the requirement of *but for* cause in situations where, since the negligence of any one of several defendants was sufficient to cause the harm, the negligence of none was its necessary cause. *See, e.g.*, *Corey v. Havener*, 182 Mass. 250 (1902). Indeed, some commentators attribute the acceptance of the "substantial factor" terminology, such as that used in Connecticut, to the problems a strict *but for* test would cause in this latter type of case. *See, e.g.*, W. Page Keeton et al., *Prosser and Keeton on the Law of Torts* § 41, at 267-68 (5th ed.1984) [hereinafter *Prosser*]. While none of these easings in the requirement of proof of *but for* cause applies directly to the case before us, it is not unlikely that developments that are relevant to the instant case, *see infra* section II(B)(4), derived from a desire to achieve analogous goals through tort law. *See generally* Guido Calabresi, *Concerning Cause and the Law of Torts: An Essay for Harry Kalven, Jr.*, 43 U. Chi. L. Rev. 69 (1975).

was the source of her illness and death, and (b) that it was not just the Danocrine, but its negligent overdose that led to Mrs. Zuchowicz's demise.

We hold that, on the basis of Dr. Matthay's testimony alone, the finder of fact *390 could have concluded—under Connecticut law—that Mrs. Zuchowicz's PPH was, more likely than not, caused by Danocrine. While it was not possible to eliminate all other possible causes of pulmonary hypertension, the evidence presented showed that the experts had not only excluded all causes of secondary pulmonary hypertension, but had also ruled out all the previously known drug-related causes of PPH. In addition, [***] that the progression and timing of Mrs. Zuchowicz's illness in relationship to the timing of her overdose supported a finding of *drug-induced* PPH to a reasonable medical certainty. In this respect, we note that in the case before us, unlike many toxic torts situations, there was not a long latency period between the onset of symptoms and the patient's exposure to the drug that was alleged to have caused the illness. Rather, [***] the plaintiff began exhibiting symptoms typical of drug-induced PPH shortly after she started taking the Danocrine. Under the circumstances, we cannot say that the fact finder was clearly erroneous in determining that, more probably than not, the Danocrine caused Mrs. Zuchowicz's illness.

To say that Danocrine caused Mrs. Zuchowicz's injuries is only half the story, however. In order for the causation requirement to be met, a trier of fact must be able to determine, by a preponderance of the evidence, that the defendant's *negligence* was responsible for the injury. In this case, defendant's negligence consisted in prescribing an overdose of Danocrine to Mrs. Zuchowicz. For liability to exist, therefore, it is necessary that the fact finder be able to conclude, more probably than not, that the *overdose* was the cause of Mrs. Zuchowicz's illness and ultimate death. The mere fact that the exposure to Danocrine was likely responsible for the disease does not suffice.

The problem of linking defendant's negligence to the harm that occurred is one that many courts have addressed in the past. A car is speeding and an accident occurs. That the car was involved and was a cause of the crash is readily shown. The accident, moreover, is of the sort that rules prohibiting speeding are designed to prevent. But is this enough to support a finding of fact, in the individual case, that *speeding* was, in fact, more probably than not, the cause of the accident? The same question can be asked when a car that was driving in violation of a minimum speed requirement on a super-highway is rear-ended. Again, it is clear that the car and its driver were causes of the accident. And the accident is of the sort that minimum speeding rules are designed to prevent. But can a fact finder conclude, without more, that the driver's negligence in *driving too slowly* led to the crash? To put it more precisely—the defendant's negligence was strongly causally linked to the accident, and the defendant was undoubtedly a *but for* cause of the harm, but does this suffice to allow a fact finder to say that the defendant's *negligence* was a *but for* cause?

At one time, courts were reluctant to say in such circumstances that the wrong could be deemed to be the cause. They emphasized the logical fallacy of *post hoc, ergo propter hoc*, and demanded some direct evidence connecting the defendant's wrongdoing to the harm. *See, e.g., Wolf v. Kaufmann*, 227 A.D. 281, 282 (1929) (denying recovery for death of plaintiff's decedent, who was found unconscious at foot of stairway which, in violation of a statute, was unlighted, because the plaintiff had offered no proof of "any causal connection between the accident and the absence of light").

All that has changed, however. And, as is so frequently the case in tort law, Chief Judge Cardozo in New York and Chief Justice Traynor in California led the way. In various opinions, they stated that: if

(a) a negligent act was deemed wrongful *because* that act increased the chances that a particular type of accident would occur, and (b) a mishap of that very sort did happen, this was enough to support a finding by the trier of fact that the negligent behavior caused the harm. Where such a strong causal link exists, it is up to the negligent party to bring in evidence denying *but for* cause and suggesting *391 that in the actual case the wrongful conduct had not been a substantial factor.

Thus, in a case involving a nighttime collision between vehicles, one of which did not have the required lights, Judge Cardozo stated that lights were mandated precisely to reduce the risk of such accidents occurring and that this fact sufficed to show causation unless the negligent party demonstrated, for example, that in the particular instance the presence of very bright street lights or of a full moon rendered the lack of lights on the vehicle an unlikely cause. *See Martin v. Herzog*, 228 N.Y. 164 (1920); *see also Clark v. Gibbons*, 66 Cal.2d 399 (1967) (Traynor, C.J., concurring in part and dissenting in part on other grounds).

The general acceptance of this view is both signaled and explained by Prosser, which states categorically:

And whether the defendant's negligence consists of the violation of some statutory safety regulation, or the breach of a plain common law duty of care, the court can scarcely overlook the fact that the injury which has in fact occurred is precisely the sort of thing that proper care on the part of the defendant would be intended to prevent, and accordingly allow a certain liberality to the jury in drawing its conclusion.

Prosser, *supra* note 6, § 41, at 270; *see also* Calabresi, *supra* note 6, at 71–73.

It is clear that Connecticut accepts this approach. [***] The case before us is a good example of the above-mentioned principles in their classic form. The reason the FDA does not approve the prescription of new drugs at above the dosages as to which extensive tests have been performed is because all drugs involve risks of untoward side effects in those who take them. Moreover, it is often true that the higher the dosage the greater is the likelihood of such negative effects. At the approved dosages, the benefits of the particular drug have presumably been deemed worth the risks it entails. At greater than approved dosages, not only do the risks of tragic side effects (known and unknown) increase, but there is no basis on the testing that has been performed for supposing that the drug's benefits outweigh these increased risks. *See generally* 21 U.S.C. § 355(d) (indicating that the FDA should refuse to approve a new drug unless the clinical tests show that the drug is safe and effective for use under the conditions "prescribed, recommended, or suggested in the proposed labeling"). It follows that when a negative side effect is demonstrated to be the result of a drug, and the drug was wrongly prescribed in an unapproved and excessive dosage (*i.e.* a strong causal link has been shown), the plaintiff who is injured has generally shown enough to permit the finder of fact to conclude that the excessive dosage was a substantial factor in producing the harm.

In fact, plaintiff's showing in the case before us, while relying on the above stated principles, is stronger. For plaintiff introduced some direct evidence of causation as well. On the basis of his long experience with drug-induced pulmonary diseases, one of plaintiff's experts, Dr. Matthay, testified that the timing of Mrs. Zuchowicz's illness led him to conclude that the overdose (and not merely Danocrine) was responsible for her catastrophic reaction.

Under the circumstances, we hold that defendant's attack on the district court's finding of causation is meritless.

Note 1. Why was it a challenge for the plaintiff to establish causation? The court offers reasoning that suggests the facts of this case made it especially difficult. When do you imagine it is *not* difficult to prove causation in cases involving pharmaceutical drugs and other complex chemicals? What level of certainty should be required in assessing causation in humans if no human trials have been conducted?

Note 2. What role does negligence per se play in this case?

Note 3. *Daubert v. Merrell Dow Pharmaceuticals, Inc.*, 509 U.S. 579 (1993). *Zuchowicz* refers to *Daubert*, a case that reformed the standards by which scientific testimony could be admitted in federal courts. Post-*Daubert*, testimony must be *both* relevant (under the Federal Rules of Evidence) and reliable (using a new list of factors cited in the opinion above) before it may be admissible. You will likely learn about *Daubert* (pronounced DOW (rhymes with cow)-burt) when you study Evidence (in law school or for the bar exam), and it's an important case for tort law's breach, causation and damages inquiries. What you need to know for tort law is that it's the applicable standard for scientific and medical evidence in federal courts. Some state courts have also adopted *Daubert* while others retained *Frye*, the older standard, which required that expert testimony be subject to "generally accepted principles." *Frye v. United States*, 293 F. 1013, 1014 (D.C. Cir. 1923).

Implications for Social Justice

Nieves v. 1845 7th Avenue Realty Associates, Supreme Court, New York County (2000) (184 Misc.2d 639)

Defendant City of New York moves, and co-defendants, 1845 7th Avenue Realty Associates, L.P., 1845 7th Avenue, Inc., Ari Parnes and Sharp Management Corp., cross-move, for an order compelling plaintiffs to provide authorizations for the siblings' complete school records, including colleges or universities attended, courses taken and grades received, teacher reports and evaluations, and the results of standardized tests, SAT and Advanced Placement tests, and psychological testing and evaluations. Alternatively, defendants move and cross-move for an order precluding plaintiffs from offering any evidence at trial regarding the academic performance of the infant plaintiff's siblings. Plaintiffs oppose the motion and cross-motion.

This is an action for damages for personal injuries sustained by the infant plaintiff, Jordan Nieves, born on September 5, 1992, as the result of exposure to lead-based paint while residing at 1851 7th Avenue, Apt. 15, New York, New York. In May 1997, defendant City served a Demand for Discovery and Inspection requesting, *inter alia*, the name, date of birth and current address of any siblings of the infant plaintiff, and for each sibling, the "[n]ames and addresses of any and all schools, pre-schools or day-care centers attended, and duly executed authorizations allowing those institutions to release their records to the defendant(s)." Plaintiffs responded with the names and dates of birth of three siblings (Kevin Michael Cleare, DOB 1/9/81; David Christopher Nieves, DOB 2/16/81; and Ishmael Cleare, DOB 10/3/83), but objected to the demand for academic information as "seek[ing] irrelevant and

private information.” In August 1998, co-defendants served a Demand for Authorizations to obtain the complete educational records of the infant plaintiff’s siblings, to which plaintiffs’ counsel objected.

In May 1999, plaintiffs served their Response for Expert Information, which identified Dr. Leon I. Charash, M.D., a pediatric neurologist, as their expert witness, and annexed his April 6, 1999 report. In that report, Dr. Charash concludes that Jordan Nieves

is behind academically and has been tested as having problems with processing of information and problems with attention deficit disorder. These are all evident on today’s examination. Within reasonable certainty his lead poisoning is causally responsible for these problems and has *641 significantly impacted upon his intelligence and his ability to achieve academically as well as his problems with coordination and speech. Finally, of course, his attention deficit problems are additionally viewed as being related to his plumbism [plumbism is the technical term for lead poisoning]. Of special interest is the fact that he has three older siblings, one of whom entered UCLA having finished high school a year earlier than normal. Another brother has done well at school and is planning to go onto college and to study law if possible. His sixteen year old brother is also doing well. There is some indication that all three of these boys have been variably placed in gifted programs through their school careers.

In support of this motion to compel or preclude, defendants contend that they are entitled to discovery regarding the siblings’ academic performance, because it bears directly on a significant issue raised by plaintiffs. Defendants assert that plaintiffs now intend to use the very evidence they deemed irrelevant and refused to give discovery on two years ago, to support their own claim that Jordan would have gone to college if he had not been exposed to lead paint. According to counsel for defendant City, when the parties appeared for a compliance conference before this Court on June 4, 1999, “plaintiffs’ attorney admitted that plaintiffs would claim at trial that Jordan would have attended college but for his lead poisoning, and intended to offer fact and expert evidence regarding how Jordan’s siblings had done academically.” Defendants argue that if plaintiffs are permitted to offer evidence as to the successful academic performance of Jordan’s brothers, defendants are entitled to the brothers’ school records, so that they will be in a position to refute plaintiffs’ claim and to cross-examine Dr. Charash and any other witnesses testifying as to this issue. Alternatively, defendants argue that if plaintiffs do not wish to provide such discovery, they should be precluded from offering any evidence of the brothers’ academic performance.

In opposition to the motion, plaintiffs assert that the brothers’ school records are not material and relevant to any issue in this action, and that defendants are entitled only to the general factual observations of the infant plaintiff’s mother, who testified at her further deposition as to the specific schools attended by the siblings and the dates of attendance. Plaintiffs assert that Dr. Charash did not examine the siblings’ school records, and the statements in his report are based on the history provided by the infant plaintiff’s father, who made general observations of his children’s academic performance. Alternatively, plaintiffs argue that if the motion to compel is granted, the records should be examined by the Court *in camera*.

*642 [***] Defendants’ motion and cross-motion to compel disclosure or to preclude are denied except to the limited extent indicated below. It is undisputed that two siblings, Kevin Cleare and David Nieves,

have both reached the age of majority, and, as such, only they, nonparties to this action, can provide the authorizations sought by defendants. [***] As neither Kevin Cleare nor David Nieves was served with the order to show cause or the notice of cross-motion, the Court lacks jurisdiction over them for the purposes of the motion and cross-motion. In any event, even if Kevin Cleare and David Nieves had been properly served, the motion and cross-motion to compel disclosure is hereby denied with respect to the academic records of all three siblings, as defendants' discovery demand is over broad, and the relevance and materiality of the requested information to any claim or defense in the action has not been established. [cc] See *Andon v. 302–304 Mott Street Assocs.*, 94 N.Y.2d 740; *Monica W. v. Milevoi*, 252 A.D.2d 260, 263 (1st Dept.1999); *McGuane v. M.C.A. Inc.*, 182 A.D.2d 1081 (4th Dept.1992).

Generally, in the reported decisions on disclosure in lead paint cases, defendants seek intelligence quotient (I.Q.) testing, and medical, academic and employment records of parents and siblings, who are usually non-parties, to dispute the issue of causation, theorizing that the requested information may lead to the discovery of admissible evidence relevant to whether the infant plaintiff's condition is the result of a genetic disorder or some environmental factor other than lead. See e.g. [cc]; *Wepy v. Shen*, 175 A.D.2d 124 (2nd Dept.1991); *643 *Baldwin v. Franklin General Hospital*, 151 A.D.2d 532 (2d Dept.1989); *Van Epps v. County of Albany*, 184 Misc.2d 159 (Sup.Ct., Albany Co.); *Espinal v. 570 W. 156th Assocs.*, N.Y.L.J., December 31, 1998, p. 27, col. 2 (Sup.Ct., N.Y.Co.); *Washington v. Bayley Seton Hospital*, N.Y.L.J., May 12, 1998, p. 25, col. 5 (Sup.Ct., N.Y.Co.); *Anderson v. Seigel*, 175 Misc.2d 609 (Sup.Ct., Kings Co.), *aff'd as modified*, 255 A.D.2d 409 (2nd Dept.1998); Alan C. Eagle & Charlotte Biblow, *Courts in Lead Cases Allow Discovery of Siblings' Academic & IQ Records*, N.Y.L.J., April 12, 1999, p. 1, col. 1; Hope Viner Sanborn, *Blame It On the Bloodline, Discovery of Non-Parties' Medical and Psychiatric Records is Latest Defense Tactic in Disputing Causation*, 85 A.B.A.J. 28 (Sept.1999); Jennifer Wriggins, *Genetics, IQ, Determinism, and Torts: The Example of Discovery in Lead Exposure Litigation*, 77 B.U.L. Rev. 1025 (1997).

In the decisions reported to date, the First Department, Appellate Division and the Second Department, Appellate Division rely on the identical legal principles in analyzing the issues on a case-by-case basis, but have split on the outcomes reached. The First Department so far has denied such disclosure, *Andon v. 302–304 Mott Street Assocs.*, 257 A.D.2d 37 (1st Dept. 1999), *aff'd* 94 N.Y.2d 740; [cc] and the Second Department has consistently granted it [cc].

The one opinion by the Court of Appeals rendered recently in *Andon v. 302–304 Mott Street Assocs.*, *supra*, affirmed the First Department, Appellate Division's denial of defendants' motion to compel the plaintiff-mother to submit to an IQ test. Rejecting defendants' argument that the Appellate Division had created a "blanket prohibition" against discovery of maternal IQ in all lead paint cases, the Court of Appeals found that the Appellate Division had "evaluated defendants' request in the context of this case and in light of the evidence presented to it. The Appellate Division concluded that the burden of subjecting plaintiff-mother to an IQ test outweighed any relevance her IQ would bear on the issue of causation. The Court noted that the mother's mental condition is not in dispute and that IQ results, while not confidential, are private. Under these circumstances, we are satisfied that the Appellate Division did not abuse its discretion as a matter of law." [fn]

*644 Here, neither plaintiffs nor defendants have made a sufficient showing that the siblings' academic records are relevant or material to the question of whether the infant plaintiff's cognitive deficits and emotional behavior problems are causally related to his ingestion of lead paint. The discovery dispute

over the siblings' academic records resurfaced when plaintiffs exchanged the report of their expert neurologist, Dr. Charash. This report includes limited second-hand information about the siblings' successful academic performance, which Dr. Charash attempts to use as further support for his conclusion that the infant plaintiff's impairments were caused by exposure to lead paint. However, any claim by plaintiffs, that there is a correlation between the infant plaintiff's impairments and his siblings' academic performance, is speculative, at best. [cc] [T]he parties have failed to produce an expert affidavit "to demonstrate that the extent to which the adverse effects of lead exposure contributed to the mental and physical condition of the infant plaintiffs cannot be ascertained by reference to objective clinical criteria and expert testimony." *Supra*, at 263, 685 N.Y.S.2d 231.

Defendants likewise fail to show how the siblings' academic information pertains to any disability or developmental impairment experienced by the infant plaintiff, as the record contains no indication that the siblings share any of the infant plaintiff's impairments. [***] To the contrary, Ms. Cleare testified that the siblings Kevin Cleare and Ishmael Cleare were never evaluated for any special education, speech or learning problems, and that they were both in gifted programs at various times.

Thus, under the circumstances presented, neither proof nor case law provides a basis for concluding that the siblings' academic records are material and relevant to the issue of causation. However, if at trial, plaintiffs intend to introduce evidence that the siblings attended certain schools or certain programs, plaintiffs shall provide defendants with documentary proof of *645 the siblings' enrollment at the schools, within 45 days of the date of this order. The court herein makes no determination as to the admissibility of such evidence at trial, which shall be reserved for the trial court.

[Defendant's motion and cross-motion denied.]

Note 1. What did the defendants' strategy appear to be with respect to the siblings' academic records it sought? What alternative strategies might be available in light of this motion's denial?

Note 2. Would it help the plaintiff on this issue to be able to bring the claim under strict liability rather than negligence? Why or why not?

Note 3. Would you distinguish between a parent and a sibling's records, with respect to an infant's exposure to a toxic environment? Is it possible that toxicity in an environment might manifest in ways that affect both parent and infant, and should that be relevant for the question of causation in fact? To what extent is genetic testing a proxy for other factors and what do you think, normatively, about its utility and appropriateness in cases of long-term injury such as this one?

Note 4. Should courts considering the use of siblings' or parents' educational records to assess causation take into account the way socioeconomic privilege and race have historically determined (and limited) educational and professional opportunities? Are structural problems like systemic inequity in education beyond the scope of tort law?

Note 5. The court cites numerous cases and articles on the topic of lead paint litigation. In fact the harms posed by lead paint are substantial and widespread. Many homes built in the first half of the twentieth century contain lead-based paint, whose use was banned starting in 1978. The lead-based paint may chip, flake or be absorbed into groundwater and dirt and thus be ingested by children in one or many forms. "Studies have linked high lead exposure to decreased fertility, spontaneous abortions, miscarriages, and other pathologies. Studies dating back to 1929 have established especially

pernicious consequences of high lead exposure to children including ...brain damage and learning disabilities, hyperactivity, and impaired hearing. Such effects are long-term.” Donald E. Lively, *The Diminishing Relevance of Rights: Racial Disparities in the Distribution of Lead Exposure Risks*, 21 B.C. Env'tl. Aff. L. Rev. 309, 314 (1994) (internal citations omitted).

The Center for Disease Control considers any reading blood-level higher than ten mg/dL, to require intervention. The Secretary of Health and Human Services has described lead poisoning as “the number one environmental threat to the health of children in the United States.” *Id.* at 316. The toxicity and ubiquity of lead-based paint present a significant public health problem. Yet its impact lands disproportionately among people of color. “[S]ignificant disparities in blood-lead levels exist on the basis of ethnicity. Recent studies have confirmed consistent and significant exposure variances correlated to race. When race and income are factored together disparities are even more egregious. An Agency for Toxic Substances and Disease Registry study disclosed that, among families with an annual income under \$6,000, the percentage of black children having blood-lead levels exceeding fifteen mg/dL is sixty-eight percent, contrasted with a level for white children of thirty-six percent. The independent significance of race is further evidenced by results showing that 26.6 percent of all African-American children, as opposed to 7.1 percent of all white children, have blood-lead levels exceeding fifteen mg/dL.” *Id.* at 317.

White flight and other demographic changes in cities have contributed to this concentration of higher-risk in lower-income communities. Whatever the other causes, the racial disparity in toxic injury is clear. What is the proper role for tort law, if any, in systematically remedying the wrongs caused by common use of lead-based paints? What is the proper role for the legislature, if any?

D.M. ex rel. Ray v. Philadelphia Housing Authority (2015) (613 Fed.Appx. 187)

D.M., a minor (“Plaintiff”), by and through her mother, Ravonnica Ray, appeals *188 the dismissal of her substantive due process claim against the Philadelphia Housing Authority (the “PHA”) for D.M.’s exposure to lead paint that occurred while she and Ray lived in Section 8 housing.¹¹¹ We will affirm. [***] Sometime before June 1, 2006, the PHA entered into a Housing Assistance Payment (“HAP”) contract with John Cassidy, the owner and landlord of an apartment building in Philadelphia, Pennsylvania (the “Property”), pursuant to the Federal Housing Choice Voucher Program under Section 8 of the United States Housing Act, 42 U.S.C. § 1437, *et seq.* (the “Section 8 Program”). Cassidy “operated, managed, maintained, [and] controlled” the Property. App. 32A.

On June 1, 2006, Ray entered into a two-year lease agreement for the Property with Cassidy. The PHA approved Ray’s lease for inclusion in the Section 8 Program and, in accordance with the HAP contract, paid Cassidy \$501 per month in subsidies on Ray’s behalf.¹¹²

¹¹¹ Although Ray is listed as an Appellant in the Opening Brief, it appears that she is involved in this case only to the extent that D.M.’s claims are brought by and through Ray. We will therefore refer to the appealing party in the singular.

¹¹² Under the Section 8 Program, tenants pay rent “based on their income and ability to pay. The PHA then makes ‘housing assistance payments’ to private landlords” that equals “the difference between the [tenant’s] contribution and

On June 1, 2008, Ray renewed her lease, which the PHA again approved for inclusion in the Section 8 Program. The lease renewal included a “Lead-Based Paint Disclosure Addendum” that was binding on Cassidy. In March 2009, the PHA inspected the Property and discovered several violations of the Section 8 Program’s Housing Quality Standards (“HQS”), including uncovered electrical outlets, broken windows, and inoperable range burners. The PHA re-inspected the Property three times in April and May 2009, and reported that Cassidy failed to address the HQS violations. None of the PHA’s inspection reports identified lead paint-related hazards in the Property.

On June 25, 2009, D.M. underwent a blood test that revealed “dangerously elevated levels of lead.” Ray sent D.M.’s blood test results to the Philadelphia Department of Health (the “DOH”), which inspected the Property and found lead-based paint on more than eighty surfaces. The DOH ordered Cassidy to eliminate the lead-based paint, but he failed to do so. D.M. and Ray eventually moved out of the Property.

Plaintiff filed a five-count Complaint against Cassidy and the PHA in connection with D.M.’s lead paint exposure. The District Court granted the PHA’s motion to dismiss under Fed.R.Civ.P. 12(b)(6), holding in pertinent part that Plaintiff’s 42 U.S.C. § 1983 state-created danger claim against the PHA failed to allege that the PHA’s approval of the Property for inclusion in its Section 8 Program was a “fairly direct” cause of D.M.’s injuries. Plaintiff appeals [The District Court dismissed all of Plaintiff’s claims against the PHA, but Plaintiff only appeals its dismissal of her state-created danger claim (Count IV)].

Plaintiff alleges that the PHA violated her due process rights by “exercis[ing its] authority in a manner” that made her “more vulnerable to danger” from lead-based paint in the Property. “[T]he Due Process Clauses generally confer no affirmative right to governmental aid, even where such aid may be necessary *190 to secure life, liberty, or property interests of which the government itself may not deprive the individual.” *DeShaney v. Winnebago Cnty. Dep’t of Soc. Servs.*, 489 U.S. 189, 196, 109 S.Ct. 998 (1989). A state actor, however, “may be held liable under the ‘state-created danger’ doctrine for creating a danger to an individual in certain circumstances.” *Henry v. City of Erie*, 728 F.3d 275, 281 (3d Cir.2013) [c].

A state-created danger claim has four elements:

- (1) the harm ultimately caused was foreseeable and fairly direct;
- (2) a state actor acted with a degree of culpability that shocks the conscience;
- (3) a relationship between the state and the plaintiff existed such that the plaintiff was a foreseeable victim of the defendant’s acts, or a member of a discrete class of persons subjected to the potential harm brought about by the state’s actions, as opposed to a member of the public in general; and
- (4) a state actor affirmatively used his or her authority in a way that created a danger to the citizen or that rendered the citizen more vulnerable to danger than had the state not acted at all.

Id. at 282. “To fulfill the ‘fairly direct’ requirement of the state-created danger claim, the plaintiff must plausibly allege that state officials’ actions precipitated or were the catalyst for the harm for which the plaintiff brings suit.” [c] “Precipitate, in turn, means to cause to happen or come to a crisis suddenly,

a ‘contract rent’ agreed upon by the landlord and the PHA.” *Truesdell v. Phila. Hous. Auth.*, 290 F.3d 159, 161 (3d Cir. 2002).

unexpectedly, or too soon.” *Id.* (internal quotation marks omitted). Thus, for purposes of the fairly direct requirement, it “is insufficient to plead that state officials’ actions took place somewhere along the causal chain that ultimately led to the plaintiff’s harm.” *Id.* (dismissing § 1983 state-created danger claim for the plaintiffs’ fire-related injuries incurred while living in Section 8 housing because the “defendants’ approval and subsidization of the apartment did not lead ‘fairly directly’ to the fire that claimed the [plaintiffs’] lives”).

Plaintiff failed to plausibly allege that the PHA precipitated, caused, or was the catalyst for her harm. Plaintiff alleges that the PHA “failed to discover” the lead paint in its March 2009 annual inspection, and “rendered plaintiff[] more vulnerable to danger than had [it] not acted at all” by: (1) including the Property in the Section 8 program despite numerous HQS violations; (2) making repeated HAP payments to Cassidy despite the HQS violations; and (3) “[r]equiring” that Plaintiff “remain” at the Property despite the “life-threatening violations of HQS” and lead paint hazards. However, Plaintiff does not allege that the PHA introduced lead paint to the Property or was responsible for its presence there.¹¹³ *See Henry*, 728 F.3d at 285 (finding no “fairly direct” causation where the plaintiffs “did not allege that [municipal] defendants caused the fire,” “increased the apartment’s susceptibility to fire,” or “failed to install a smoke detector and a fire escape”). Nor does Plaintiff allege that the PHA increased the quantity of lead paint in the Property or “did anything to hinder [Cassidy] from bringing [the Property] into compliance” with HQS. *Id.* at 285. While the PHA subsidized the Property and was allegedly “aware of the dangers that [Plaintiff] faced . . . , it played no part in their creation, nor did it do anything to *191 render [Plaintiff] any more vulnerable to them.” *DeShaney*, 489 U.S. at 201. In short, Plaintiff’s allegations fail to show “that [the PHA] created the danger” Plaintiff faced while living in the Property. *Henry*, 728 F.3d at 286.¹¹⁴

For the foregoing reasons, we will affirm.

Note 1. How significant was the fact that the plaintiff signed a lease with a lead discloser addendum, do you think? Have you signed such documents before? Do you read them thoroughly before signing? Have you ever chosen *not* to go through with signing a document because of discovering a particular term, clause, or disclosure? Regardless of the plaintiff’s awareness of the lead, should it bar her infant daughter’s right of recovery? Why or why not?

Note 2. The **state-created danger doctrine** provides a cause of action against a state official that is analogous in several respects to negligence claims against private individuals. Reviewing the 4-pronged test set out above, do you see parallels to duty, breach, causation and damages? Do you see how the plaintiff’s case could be said to have failed due to lack of causation, or her inability to prove it?

Note 3. Is the causation requirement fatally flawed in the context of chemical or toxic torts? At least one scholar has called for its elimination. Margaret A. Berger, *Eliminating General Causation: Notes*

¹¹³ Plaintiff concedes that the lead paint was present when Ray and D.M. moved into the Property.

¹¹⁴ Plaintiff’s attempts to distinguish *Henry* are unpersuasive. In *Henry*, the plaintiffs alleged that Erie, Pennsylvania’s housing authority caused their injury by allowing them to reside in a location without smoke detectors or fire alarms. 728 F.3d at 285. In this case, Plaintiff alleges that the PHA wrongly permitted Ray and D.M. to reside in a location in which lead paint was present. *Henry* rejected this as a basis for liability because the Erie housing authority’s actions were not the fairly direct cause of the injury. The cause of the *Henry* injury was the fire and the alleged cause of D.M.’s injury was the lead paint placed there by the landlord. Thus, *Henry* is indistinguishable.

Towards A New Theory of Justice and Toxic Torts, 97 Colum. L. Rev. 2117, 2145 (1997) Berger points to asbestos litigation as a paradigmatic example and observes that manufacturers knew about its risks and harms long before they were willing to disclose them to the public. This failure to disseminate information in a responsible manner had several negative consequences. It augmented the number of people who suffered from asbestos exposure, contributed to burdening judicial dockets, and ultimately made causation more challenging to establish as well. *Id.* at 2143. Berger argues that the problem is structural; businesses are incentivized to behave in this way:

Even when a corporation is well-aware of the risk it is creating, it may gamble that the future costs for compensation and litigation and administrative penalties, offset by insurance and discounted by inflation, will be less than the current cost of adding safety measures, providing information, or paying for more research. Moreover, once the corporation acknowledges the foreseeability of a toxic tort problem, particularly if there are many potential plaintiffs, the price of its stock may drop in anticipation of lawsuits with enormous transaction costs and huge settlement potential. Such a result is, of course, extremely unpalatable, both because corporate managers' chief obligation is to their current shareholders, and because the increasing use of stock options as a major component of corporate remuneration means that their own compensation may be tied directly to stock performance. The conflict between short-term and long-term consequences puts management into a bind. The uncertainty about the future proof of causation and the time-lag before anything definitive will emerge tip the balance in favor of resolutions that maximize short-term objectives. *Id.* at 2139-2140.

Berger proposes conditioning liability in negligence on failure to provide substantial information relating to risk. Instead of the *plaintiff's* needing to prove causation, defendants would benefit from a kind of safe harbor. Provided they proved that they had complied with a mandatorily established standard of care, potential defendants would be insulated from liability for injuries caused by exposure to their products. Berger proposes two additional defenses, "as a matter of fairness and as an inducement to conduct future research." The first would allow defendants to prove that certain adverse health reactions could not plausibly arise from exposure to their product; the second would allow a reduction of damages in cases in which defendants prove that "a particular plaintiff's injury is attributable or partly attributable to another cause, such as smoking." *Id.* at 2144-2145.

Does Berger's idea strike the right balance, in your view? Do her additional defenses effectively create a backdoor requirement of causation for certain plaintiffs, in the language referring to injury's being "attributable to another cause"? Referring to tort law's various purposes, what arguments support maintaining causation versus eliminating or modifying it?

Joint and Several Liability

Joint and several liability is a rule followed in many jurisdictions that allows a plaintiff whose **harm was caused by more than one tortfeasor to recover the full amount of their compensation from any single one of the individuals or from them as a group.** The benefit of the rule, from the plaintiff's perspective, is that if one of the tortfeasors is immune to liability, judgment proof,

unidentified or otherwise unavailable, the plaintiff can recover that party's portion from other tortfeasors. Likewise, if there is one party with deep pockets (or a relevant insurance policy), the plaintiff stands a better chance of receiving the compensation tort law would ostensibly award them if the plaintiff can proceed directly against the deep-pocketed party rather than seeking compensation from multiple parties. From the defendants' perspective, joint and several liability can seem quite unfair because it doesn't necessarily track the amount of the tortfeasor's fault. Further, one party may be better or worse able to pay a judgment and yet still find they owe such a payment regardless of their lesser capacity to pay it. Despite its name, "joint and several liability" is a rule of allocation as much as a rule of liability. In some cases, it is used to find liability with respect to a tortfeasor whose involvement cannot be as clearly established as others also involved; in other cases, it is used to reallocate or shift from one defendant to another the obligation to compensate the plaintiff for the injuries caused by a group of defendants' wrongful conduct. Often, the party who satisfies the judgment will seek contributions or indemnification from the other tortfeasors.

"Several liability" means a plaintiff whose harm was caused by more than one tortfeasor can proceed against an individual tortfeasor only for the amount that tortfeasor personally owes under the judgment; the plaintiff may not seek the amount of the full judgment against the group from a single plaintiff in the way joint and several liability permits.

Jurisdictions have arrived at various different rules regarding joint and several liability. It is not uncommon, even in states that retained joint and several liability, to have limited it in certain domains (such as medical malpractice or products liability cases).

Smith v. Cutter Biological, Inc., Supreme Court of Hawai'i (1991) (72 Haw. 416)

[By certified question from *Smith v. Cutter Biological, Inc.*, 911 F.2d 374 (9th Cir. 1990)]

[***] Question 3. Would Hawaii allow recovery in this case when the identity of the actual tortfeasor cannot be proven? If Hawaii would allow recovery, what theory (i.e. burden-shifting, enterprise liability, market share or other) would the Hawaii Supreme Court adopt?

[***] The instant problem is that the plaintiff cannot identify which particular defendant caused his injury. Our consideration of the issues is limited to the facts as stated in this record. Procedurally, this case reached the Ninth Circuit Court on a summary judgment motion. The order granting summary judgment did not rule on duty and breach as to the manufacturers; summary judgment was granted on the basis that plaintiff failed to prove causation. The other elements of negligence, i.e., duty, breach and damages, are not at issue here. We note that at least two courts have determined, in cases similar to the instant action, that there was no breach of duty. *Jones v. Miles Laboratories, Inc.*, 887 F.2d 1576 (11th Cir.1989); *McKee v. Cutter Laboratories, Inc.*, 866 F.2d 219 (6th Cir.1989). However, those cases are distinguishable.¹¹⁵ We do not render an opinion as to whether appellant here will overcome

¹¹⁵ The first distinction is that jurisdictionally, those courts' decisions are not controlling here. Second, in *Jones*, the negligence was based on the failure of the defendant to use "high risk" questioning as to the specifics of whether the donor was a homosexual. *Jones*, 887 F.2d at 1580. The decision was based solely on the fact that the donor, who was clearly identified, would not and did not admit that he was a member of one of the "high risk" groups for AIDS. *Id.* at

the obstacles met by plaintiffs in those cases; the duty and breach issue here has not only not been decided, it is not before this court on the certified questions. Therefore, we do not deal with the viability of those questions.

421** Our conclusions deal only with this case—as it comes to us. Therefore, on our reading of the record as it stands, the relevant statutes, and the relevant case law, [] our answer to question three is “yes,” using the alternative market share theory of recovery, as defined herein.¹¹⁶

Appellant is a hemophiliac who has tested HIV-positive with the AIDS virus.¹¹⁷ He claims that his exposure to the AIDS virus occurred in 1983 or 1984, through injections of the Antihemophilic Factor Concentrate (Factor VIII or AHF). [fn] Factor ***422** VIII, as more fully discussed in Part III, is a blood protein which enables the blood to properly coagulate when a hemophiliac suffers a bleeding episode. The original source of the Factor VIII is through blood donors.

The United States Tripler Army Medical Hospital (U.S.) was appellant’s dispensary for Factor VIII during the period of time in which appellant claims to have been infected. According to appellant, appellee manufacturers [fn] furnished to the U.S., the Factor VIII which was used by appellant. Upon appellant’s first being tested for HIV antibodies in 1986, the results were positive.

Appellant filed suit against the four appellee manufacturers of Factor VIII for negligence and strict liability.¹¹⁸ Defendants moved for summary judgment. Despite acknowledging “that this is a case in which it might be reasonable to apply the principles of market ***423** share theory of liability,” the district court granted summary judgment in favor of appellees, holding that appellant failed to prove specifically which manufacturer’s product caused his infection. Appellant took the case to the Ninth Circuit, which certified the questions to this court. [***] ***425** IV.

The reason this case is before this court is because the legislature has not fully legislated in the field of torts. When the occasion arises for which there is no specific rule to apply, “we are free to fashion an appropriate rule of law.” *Armstrong v. Cione*, 69 Haw. 176, 738 P.2d 79 (1987). We must consider

1581. In *McKee*, the finding of no negligence was based on the fact that at the time of the decedent’s being diagnosed with AIDS, in October 1983, industry custom did not require the processes developed later to inactivate the AIDS virus. *McKee*, 866 F.2d at 224. A final distinction is that in both cases, the specific manufacturer was named. On the other hand, at least one court has approved application of the market share theory of liability on facts similar to those herein. *Ray v. Cutter Laboratories*, 754 F.Supp. 193 (M.D. Fla. 1991). *Ray* was also considered at the summary judgment stage, but the federal court adopted the market share theory as that was the only multi-tortfeasor theory of liability then approved by the state supreme court. *Id.* at 195.

¹¹⁶ Defendants include not only the manufacturers—Armour Pharmaceutical Corporation, Cutter Biological, Inc., Alpha Therapeutics Corporation, and Travenol Laboratories, Inc. (now Baxter Laboratories)—but also the United States of America (U.S.). The allegations against the U.S. are based on negligence and failure to warn. Although designated as an appellee, the U.S. has not filed an answering brief. We note that the claims against the U.S. are not directly pertinent to the certified questions before this court.

¹¹⁷ AIDS is an infectious disease caused by a virus, as are herpes, smallpox, yellow fever, and hepatitis. R. Jarvis, M. Closten, D. Hermann, A. Leonard, *AIDS LAW in a Nutshell* 1 (West Publishing 1990) (hereinafter *AIDS Nutshell*). The disease was uniquely recognized in June and July, 1981. *Id.* at 5. There are several modes of infection: 1. sexual intercourse, 2. sharing infected syringes, 3. receipt of human tissue, blood, etc., and 4. child birth or breast feeding. *Id.* at 7. Once infected, a victim will not test positive for HIV during a “window” period, which lasts between six weeks and six months—although some researchers say the window period may be several years. *Id.* at 14. Although testing positive, a person may continue to be asymptomatic for seven to ten years. *Id.*

¹¹⁸ Appellant, at one point, attempted to convert this suit to a class action, but failed to follow through on the opportunity. Our analysis of the theories of liability might differ, were this a class action.

what justification there is for deviating from the traditional proof in a negligence case, which, as this court has previously said, includes the factor of causation. See *Knodle v. Waikiki Gateway*, 69 Haw. 376, 385 (1987).

Appellees take issue with applying theories which were developed, in a large part, for remedies in the field of diethylstilbestrol (DES) drug litigation and the inherent problems associated with those actions.[fn] Their strongest argument against using these theories *427 is the lack of comparison of DES to Factor VIII as a fungible product. DES was produced by more than 200 different companies, some of which are defunct, but the identical formula was used universally in a highly regulated industry. With Factor VIII, there are only a handful of manufacturers, and although the product is fungible insofar as it can be used interchangeably, it does not have the constant quality of DES. The reason is obvious—the donor source of the plasma is not a constant. Therefore, Factor VIII is only harmful if the donor was infected; DES is inherently harmful. As we see that the lack of screening of donors and failure to warn are the breaches alleged, appellee’s argument for not using DES theories is not convincing. We find consideration of the theories discussed in the DES cases to be helpful, as we strive to find an equitable and fair solution to the case at bar.

Our initial reference is to the reasoning of the Supreme Court of California, in *Sindell v. Abbott Laboratories*, 26 Cal.3d 588, cert. denied, 449 U.S. 912 (1980). We subscribe to the policy reasons propounded in *Sindell*, and discussed *infra*, for by-passing the identification requirement.

In addition, we note that tort law is a continually expanding field. As discussed in the American Law Institute Enterprise Responsibility for Personal Injuries—Reporter’s Study (1991) (ALI Study), the field of torts has now expanded to include personal injury actions described in three tiers of actions. I ALI Study 9. These are loosely defined as first, the traditional level which includes accidents where an individual defendant causes harm to a stranger. The second level includes product defects and medical mishaps which include high stakes cases with erratic jury *428 results. Finally, the third tier includes “mass” torts where toxic exposure to many plaintiffs may, many years later, cause cancer or other illness. *Id.* at 9–10. It is this final tier with which this case deals. It necessitates considering how to fairly deal with the plight of plaintiffs unable to identify, for no fault of their own, the person or entity who should bear the liability for their injury.

No longer can we apply traditional rules of negligence, such as those used in individual and low level negligence to mass tort cases, especially here, where we are dealing with a pharmaceutical industry that dispenses drugs on a wide scale that could cause massive injuries to the public, and where fungibility makes the strict requirements difficult to meet. The problem calls for adopting new rules of causation, for otherwise innocent plaintiffs would be left without a remedy. We concede that there is a difference of opinion regarding the need for this change. For instance, in regard to DES cases, the Illinois Supreme Court refused to adopt the market share theory of liability, in part because “[a]cceptance of market share liability and the concomitant burden placed on the courts and the parties will imprudently bog down the judiciary in an almost futile endeavor.” *Smith v. Eli Lilly & Co.*, 137 Ill.2d 222, 253 (1990). In addition, that court criticized the fairness of results in apportioning damage when reliable information on all manufacturers might not be available. *Id.* Part of that reasoning, of course, is based on the fact that the potential number of defendants in DES cases extends into the hundreds. *Id.* at 254, 148 Ill. Dec. at 36. The numbers here are not nearly so large, and therefore, the harshness of the result, that is, burdening the innocent plaintiff without a remedy, to us seems totally unfair and out of step with current efforts to allow recovery when the proper case is brought.

The policies in *Sindell* and *Hall* convince us that it is appropriate to consider a negligence action where the actual tortfeasor cannot be proven. Therefore, although inherent in the proof of *429 negligence is proof of causation, we believe that this state is amenable to consideration of group theories of liability.

[***] There are several theories which have evolved in the last several years. The genesis of these theories comes from *Sindell v. Abbott Laboratories*, 26 Cal.3d 588 (1980). The theories are generally described as: alternative liability, concert of action, enterprise or industry-wide liability, and market share liability. In the evolution of the DES cases, the market share theory has undergone various modifications, to suit the policies and needs of the particular courts.

A. Alternative Liability

This theory is epitomized in the well-known case of *Summers v. Tice*, 33 Cal.2d 80, 199 P.2d 1 (1948). In that case, two hunters negligently shot in the direction of the plaintiff; one of them injured him. Upon deciding that both were wrongdoers and negligent to the plaintiff, the court felt that it was unfair to leave an impossible burden of proof on the plaintiff, and shifted that burden to the defendants to absolve themselves. The rule of *Summers v. Tice* is included in the *Restatement (Second) of Torts (Restatement)* as follows:

Where the conduct of two or more actors is tortious, and it is proved that harm has been caused to the plaintiff by only one of them, but there is uncertainty as to which one has caused it, the burden is upon each such actor to prove that he has not caused the harm.

*430 *Restatement* § 433B (3) (1965). The comments in the *Restatement* also suggest that this theory may appropriately be subject to modification at a later time. *Id.*, comment h.

Two presumptions follow this theory. First, the plaintiff must prove that “all defendants acted tortiously and that the harm resulted from the conduct of one of them.” *Sindell*, 163 Cal.Rptr. at 139 n. 16, citing *Restatement* § 433B, comment g. This has been interpreted to mean that the tortious actions must occur simultaneously. *Starling v. Seaboard Coast Line R.R.*, 533 F. Supp. 183, 191 (S.D.Ga.1982) (court considering theories in asbestos related injury). However, another court, in applying the theory in a Factor VIII case, disagreed. *Poole v. Alpha Therapeutic*, 696 F. Supp. 351, 356 (N.D. Ill.1988).

Second, all responsible parties must be joined. *Sindell*, 163 Cal.Rptr. at 139. Typically, this theory is useful in multiple car crash cases, cases of pollution by several defendants, and injury during medical operations where the plaintiff is sedated. *Agent Orange Litigation*, 597 F. Supp. 740 (E.D.N.Y.1984). Additionally, however, joint and several liability is inherent in the application of alternative liability.

We choose not to alter the theory to the point that it would be useful on the facts here. Several problems arise which lead us to this decision. First, we look at the various theories of negligence which appellant suggested. One argument is that there was a duty to properly select and screen donors; other arguments follow the same line of reasoning—that the manufacturers should have implemented verified surrogate laboratory tests, or that they should have ceased using plasma from donor centers where the population groups had significant numbers of AIDS incidents. It is obvious that each manufacturer acted at various different times, so the simultaneous requirement of a strict application of the theory *431 fails. Also, although appellant has alleged that manufacturers are “most” of the possible tortfeasors, and the manufacturers have not clearly rebutted that argument, it is still subject to factual proof and findings. Finally, we do not believe that joint and several liability is appropriate under the circumstances of this

case. Therefore, this theory cannot be applied here, unless modified, and we choose not to do so based on these facts, as other theories, discussed *infra*, have already been appropriately modified.

B. Concert of Action

This theory derives from the criminal law concept of aiding and abetting. *Starling*, 533 F. Supp. at 187. See *Restatement* § 876. Concert of action is usually applied with a small number of defendants, a single plaintiff, and a short time period between the tort and its discovery. The defendants' joint plan is the basis of the cause of action, and most often the plaintiff is able to identify which defendant actually caused the injury. *Abel v. Eli Lilly and Co.*, 418 Mich. 311, 338, *cert. denied sub nom, E.R. Squibb & Sons, Inc. v. Abel*, 469 U.S. 833 (1984).¹¹⁹ The court stated that the identification did not preclude use of the theory. *Id.* According to the court, the only burden of plaintiffs to withstand a summary judgment motion, for failure to state a cause of action, was to "allege that the defendants were jointly engaged in tortious activity as a result of which the plaintiff was harmed." *Id.* Inherent in this theory is the application of joint and several liability. As the Michigan court also stated, "[i]f plaintiffs can establish that all defendants acted tortiously pursuant to a common design, they will all be held liable for the entire result." *Id.* *432 Even if we thought this theory appropriate in a Factor VIII case, again, we do not wish to burden defendants with joint and several liability. Therefore, we choose not to allow this theory to be applied to this case.

C. Enterprise or Industry–Wide Liability

The essence of the enterprise theory is that there is joint control of the risk throughout a particular industry. The theory originated in the blasting caps case, *Hall v. E.I. DuPont de Nemours & Co., Inc.*, 345 F. Supp. 353 (E.D.N.Y.1972). The basis of the case was that there was an industry-wide standard concerning safety; the safety planning was delegated to a central group; and there was cooperation in the manufacture and design. Policy dictates that when all of those facts occur, the entire enterprise is liable. Therefore, the industry-wide standard became the cause of the plaintiff's injury.

The main premise against this theory is stated in one of the DES cases:

The underlying rationale in all of the decisions rejecting enterprise liability is that the law of torts does not include a theory of liability which would allow an entire industry to be held strictly liable for an injury caused by a defective product. Enterprise liability as described in *Hall* is predicated upon industry-wide cooperation of a much greater degree than that alleged by the plaintiff.

Martin v. Abbott Laboratories, 102 Wash.2d 581, 600 (1984). That premise is directly disputable by reading *Hall*, as the court states:

There is thus no support for defendants' argument that to establish joint control of risk, plaintiffs must demonstrate that the explosives industry was "rigidly *433 controlled" through the trade association with regard to blasting cap design, ... and that the object of such control was some particularly reprehensible breach of duty. The variety of business and property relationships in which joint control of risk has been found

¹¹⁹ The Michigan court allowed this theory to be applied in a DES case, which had reached the court on summary judgment, where it appeared the plaintiff could identify the tortfeasor. *Abel v. Eli Lilly & Co.*, 418 Mich. 311, 343 N.W.2d 164, *cert denied*, 469 U.S. 833, 105 S. Ct. 123, 83 L. Ed. 2d 65 (1984).

demonstrates the flexibility of the doctrine. Liability is not limited to particular formal modes of cooperation, nor to illegal or grossly negligent activities.

Hall v. E.I. DuPont de Nemours, 345 F. Supp. at 374.

However, another court has aptly stated the plaintiff's burden of proof with a showing:

- (1) that the product was manufactured by one of a small number of defendants in an industry;
- (2) the defendants had a joint capacity to reduce the risks of the product; and
- (3) each of them failed to take steps to reduce the risk at a substantially concurrent time by delegating their responsibility to an association.

Conley v. Boyle Drug Co., 477 So.2d 600, 604 (Fla.App.1985), *rev'd on other grounds*, 570 So.2d 275 (Fla.1990) (specifically approving the analysis of the lower court as to alternative, concert of action, enterprise, and *Sindell* market share theories of liability).

Based on the steps as set forth in *Conley*, the enterprise theory appears to be somewhat persuasive a method of approaching this case. We note that the pleadings do not raise the allegation that the defendants had the joint capacity to reduce the risk. Appellant does not even argue this theory in his opening brief; however, the facts alleged in the brief lend credibility to this type of argument. Were it not that we are again faced with the inherent application of joint liability, and the fact in addition, that we find one aspect of the *Hall* scenario convincingly distinguishable, we might endorse this theory in answer to the certified question.

***434** First, we mention the distinguishable characteristic of *Hall*, which is convincingly pointed out to us by appellees and the court in *Sindell v. Abbott Laboratories*, 26 Cal.3d 588 (1980). The court there noted that "the drug industry is closely regulated by the Food and Drug Administration, ... [t]o a considerable degree, therefore, the standards followed by drug manufacturers are suggested or compelled by the government." *Id.*, 163 Cal.Rptr. at 143. With the government in control of the parties' actions, it is unfair to hold them liable for following the standards. Appellees' arguments convince us that such reasoning is appropriate here, too, to eliminate this theory on these facts.

We further digress to expound on our reluctance to adopt joint liability in the Factor VIII cases. First, as we are writing a new chapter in tort law in the State of Hawaii, we endeavor to set principles which we think would be adopted by our legislature. We note that by statute, joint and several liability in tort will be abolished to some extent as of October 1991. HRS § 663–10.9 (Supp.1990). As to what is still allowed, damages are still limited by the doctrine of modified comparative negligence. HRS § 663–31 (1985). Therefore, we believe the legislature has seen a need to balance the equities in this evolving field.

In addition, as noted by many of the opinions in DES cases, there is an inherent unfairness in holding one or two parties responsible in full for the actions of tortfeasors who may escape liability for some reason. It seems at least a fair trade-off, where the plaintiff cannot identify which party actually caused his injuries, to at least allow the defendants to limit their share of liability to their relative proportion of the market. Therefore, we move on to discuss, and endorse, market share liability, with modifications.

D. Market Share Liability & Its Progeny

This theory has been most susceptible to variations and refinements, especially in DES litigation, but also in line with the *435 law of the state in which it has been applied. It was first defined in *Sindell*, 26 Cal.3d 588 (1980). The policies there stated included: 1. the reasoning of *Summers v. Tice*, 33 Cal.2d 80 (1948), that between innocent plaintiffs and negligent defendants, the negligent party should be held liable; 2. advances in science and the creation of fungible goods whose source cannot be traced; 3. the financial ability of defendants to bear the costs; and 4. the fact that manufacturers are in the better position to prevent defective products from reaching the consumer market. *Sindell*, 163 Cal.Rptr. at 144. We expand on those policies to acknowledge that defendants may bear the loss by passing that cost of doing business on to consumers. In addition, we feel that equity and fairness calls for using the market share approach. Another justification is that where many drugs can be lethal, and it is difficult for the consumer to identify the source of the product, the burden should shift. The concept itself meets the objectives of tort law, both by providing plaintiffs a remedy, but also by deterring defendants from negligent acts.

After stating its policies, the *Sindell* court stated:

[W]e hold it to be reasonable in the present context to measure the likelihood that any of the defendants supplied the product which allegedly injured plaintiff by the percentage which the DES sold by each of them for the purpose of preventing miscarriage bears to the entire production of the drug sold by all for that purpose.

Id. at 145. Included in the definition was a requirement that a substantial percentage of the market must be joined as defendants, and that an exculpatory clause be included. *Id.* We feel that this basic theory, with modifications and distinctions to suit the policies of this state, discussed *infra*, provides an appropriate model for appellant's case. The relevant considerations *436 are: 1. defining the market, 2. identification and joint and several liability, and finally 3. exculpatory allowances.

1. *Defining the Market*

Criticisms of *Sindell* include the need for a definition of "substantial share" of the market, in order not to distort the share of liability. *Martin v. Abbott Laboratories*, 102 Wash.2d 581, 602 (1984). The *Martin* court adopted a narrow definition of the market, that being the plaintiff's particular geographic market. *Id.* at 605. The justification is that the narrow market share purports to make a "particular defendant's potential liability ... proportional to the probability that it caused plaintiff's injury." *Id.* This policy was later reaffirmed by the same court, with acknowledgement that lacking evidence of the specific market, then "other figures, ... such as within the county, state, or even in the country may in certain circumstances be introduced." *George v. Parke-Davis*, 107 Wash.2d 584, 592 (1987). The Florida Supreme Court, in *Conley v. Boyle Drug Co.*, 570 So.2d 275 (Fla.1990), agreed with the Washington court that the relevant market should be "as narrowly defined as the evidence in a given case allows." *Id.* at 284. The court found this manner of definition to be consistent with the *Martin* theory of allowing a defendant to exculpate itself by showing no participation in that market. It does meet the goal of market-share liability to impose liability only on those companies who could have manufactured the injurious product.

Another court has specifically adopted the national market as the best option. *Hymowitz v. Eli Lilly and Co.*, 73 N.Y.2d 487, 511 (1989). Several premises supported this holding: 1. it was difficult to

reliably determine any market smaller than the national one, 2. it avoided the need to establish separate *437 matrices as to market share, and 3. it avoided an unfair burden on litigants. *Id.* at 511. The national market was intended to “apportion liability so as to correspond to the over-all culpability of each defendant, measured by the amount of risk of injury each defendant created to the public-at-large.” *Id.* at 512. This provides equitable relief for plaintiffs, and a rational distribution of responsibility among defendants. It also avoids a windfall escape to the producer who happens to sell only to certain distributors. The culpability, therefore, is for marketing the product.

As we are faced here with a minimal number of manufacturers of the product, we believe that culpability for marketing the product is a better policy. Should the issue arise under different circumstances at some point, we may find it appropriate to narrow the definition. For this case, however, we believe the national market is the more equitable consideration.

2. Identification and Joint and Several Liability

Courts differ on their requirements of an assertive effort on the part of plaintiffs to identify the actual manufacturer of the specific product which caused the harm. We take another approach to this concern. Whereas manufacturers here argue that appellant should have kept a log of which manufacturer’s product he was using, we fail to see how such failure affects the viability of appellant’s suit in view of our adoption of the theory of market share liability.

Plaintiffs should use due diligence to join all manufacturers, but failure to do so is not a defense. Failure to do so may affect the percentage of recovery, discussed *infra*. However, manufacturers are permitted to implead other manufacturers. But, in this case, all manufacturers are joined, so the issue is not before us. However, we note in passing that the conditions of the *Martin* court, which would allow plaintiffs to initiate suit against only one defendant, *438 and of *Sindell*, which would require plaintiffs to join a “substantial” number of defendants, are immaterial as long as plaintiffs realize their recovery will depend on joining as many manufacturers as they can; plaintiffs will endeavor to join all manufacturers.

We have already discussed our feeling that this action should not be subject to joint liability. We simply reiterate what other courts have said on this point, that “[t]he cornerstone of market share alternate liability is that if a defendant can establish its actual market share, it will not be liable under any circumstances for more than that percentage of the plaintiff’s total injuries.” *Conley*, 570 So.2d at 285, quoting *George v. Parke–Davis*, 107 Wash.2d at 595. Therefore, we advocate several liability.

We define the rules of distribution as to market share for this case as was done in *Martin*, that is:

The defendants that are unable to exculpate themselves from potential liability are designated members of the plaintiffs’ ... market[].... These defendants are initially presumed to have equal shares of the market and are liable for only the percentage of plaintiff’s judgment that represents their presumptive share of the market. These defendants are entitled to rebut this presumption and thereby reduce their potential liability by establishing their respective market share of [Factor VIII] in the ... market.

Martin, 102 Wash.2d 581, 605 (1984). As to several liability, we adopt the theory that a particular defendant is only liable for its market share. Defendants failing to establish their proportionate share of the market will be liable for the difference in the judgment to 100 percent of the market. However,

should plaintiff fail to name *all* members of the market, the plaintiff will not recover 100 percent of the judgment if the named defendants prove an aggregate share of less than 100 percent.

3. *Exculpatory Allowances*

As a result of our determination that a national market is appropriate, as long as defendant is actually one of the producers of Factor VIII, there is little to justify exculpation of defendant. However, the exception would occur where defendant could prove that it had no product on the market at the time of the injury. As far as the defendants in this suit are concerned, it appears that none of them would be able to escape liability on that basis.¹²⁰

In conclusion, we will recognize the basic market share theory of multi-tortfeasor liability, as defined herein. Acknowledging that this could open a Pandora's box of questions, we believe that we have defined at least a starting point as to appropriately responding to the certified questions. However, as we are deciding issues in a virtual factual vacuum, we recognize that our opinion is limited to the facts presented to us, and we reserve the right to modify or amend our answers to these questions.

MOON, Justice, concurring and dissenting.

[***][T]he majority's departure from well established tort law in Hawaii is based on a factual record that prevents plaintiff from establishing the existence of a legal duty and breach of *441 that duty, based on a provable standard of care, which is essential to the application of the market share theory of liability. [***]

Initially, it is important to note that until today, negligence liability under Hawaii law required a plaintiff to prove by a preponderance of the evidence four essential elements: 1) the existence of a legal duty; 2) breach of that duty; 3) causation; and 4) injury. *Knodle v. Waikiki Gateway Hotel, Inc.*, 69 Haw. 376 (1987). However, the market share liability theory imposes liability without requiring identification of the wrongdoers who caused plaintiff's harm and shifts the burden to defendants to prove that they did not cause the plaintiff's injury. Eliminating causation as an element of proof and shifting the burden to the defendant is [***] a radical departure from traditional negligence law. [***]

In 1988, the American Medical Association reported that "in the pharmaceutical industry, meaningful product liability insurance has all but disappeared." A.M.A., *Report of the Board of Trustees on Impact*

¹²⁰ The precursor of the DES cases is *Sindell v. Abbott Laboratories*, 26 Cal.3d 588 *cert. denied*, 449 U.S. 912 (1980). *Sindell* arose when demurrers were sustained as to several manufacturers of DES, on the basis that plaintiff could not identify whose product caused the injury. *Id.*, 163 Cal.Rptr. at 134, n. 3. The *Sindell* court considered the four main theories. Michigan approved both the concert of action and alternate liability theories in a DES case up on summary judgment. *Abel v. Eli Lilly and Co.*, 418 Mich. 311 (1984). In the same year, the Washington Supreme Court addressed the issue on appeal from summary judgment, in *Martin v. Abbott Laboratories*, 102 Wash.2d 581 (1984). The *Martin* court reanalyzed the theories enumerated in *Sindell*, and then created the market-share alternate liability. A federal court in Illinois tentatively allowed the alternate liability theory in a DES case, acknowledging that the Illinois Supreme Court had not yet addressed the issue. *Poole v. Alpha Therapeutic Corp.*, 696 F.Supp. 351 (N.D.Ill.1988). Later, the Illinois Supreme Court did address a DES case, but only as to the market share theory of liability—which it refused to adopt. *Smith v. Eli Lilly & Co.*, 137 Ill.2d 222 (1990). In New York, as in Florida, state courts adopted market share theories as viable in DES cases. *Hymowitz v. Eli Lilly and Co.*, 73 N.Y.2d 487 (1989) (on certified questions, and adopting the national market as the base market); *Conley v. Boyle Drug Co.*, 570 So.2d 275 (Fla.1990) (adopting Washington's version of market share liability, and summarily disposing of the other theories).

of *Product Liability on the Development of New Medical Technologies 2* (1988). This lack of insurance is largely due to the development of non-identification theories of liability.¹²¹

446** The application of the market share liability theory may result in liability being placed on defendants bearing no responsibility for the defective product and may create unpredictable costs to innocent parties [] The primary authority cited by the majority in support of its position is the DES case of *Sindell v. Abbott Laboratories*, 26 Cal.3d 588, cert. denied, 449 U.S. 912 (1980), which was the first to judicially promulgate the market share liability theory. In *Sindell*, the “DES daughter” plaintiff sought to recover damages for injuries resulting from cancer caused by DES, a miscarriage preventative. The mother ingested the drug over twenty years prior to the cause of action being filed. The trial court dismissed the action on the ground that plaintiff had conceded that the specific manufacturers of the drug could not be identified.

On appeal, the Supreme Court of California adopted the market share liability theory, which relieved plaintiff of the burden of identifying which of over 200 companies manufactured the DES drug ingested by her mother. The court, in reaching this ***447** conclusion, reasoned: “In our contemporary complex industrialized society, advances in science and technology create fungible goods which may harm consumers and which cannot be traced to any specific producer.” *Sindell*, 26 Cal.3d at 610. The court determined that two essential factual elements, fungibility and the inability to identify specific producers, must be present in order for the market share liability theory to be appropriate. Both elements are glaringly absent in the Factor VIII case before us. [***]

The primary authority cited by the majority in support of its position is the DES case of *Sindell v. Abbott Laboratories*, 26 Cal.3d 588, cert. denied, 449 U.S. 912 (1980), which was the first to judicially promulgate the market share liability theory. In *Sindell*, the “DES daughter” plaintiff sought to recover damages for injuries resulting from cancer caused by DES, a miscarriage preventative. The mother ingested the drug over twenty years prior to the cause of action being filed. The trial court dismissed the action on the ground that plaintiff had conceded that the specific manufacturers of the drug could not be identified.

On appeal, the Supreme Court of California adopted the market share liability theory, which relieved plaintiff of the burden of identifying which of over 200 companies manufactured the DES drug ingested by her mother. The court, in reaching this ***447** conclusion, reasoned: “In our contemporary complex industrialized society, advances in science and technology create fungible goods which may harm consumers and which cannot be traced to any specific producer.” *Sindell*, 26 Cal.3d at 610. The court determined that two essential factual elements, fungibility and the inability to identify specific producers, must be present in order for the market share liability theory to be appropriate. Both elements are glaringly absent in the Factor VIII case before us. [***]

IV. *Judicial Restraint*

The majority’s primary reason for adopting the market share liability theory, in a form that is even more expansive than in *Sindell*, is that “the harshness of the result, that is, burdening the innocent

¹²¹ See United States Department of Justice, Report of the Tort Policy Working Group on the Causes, Extent and Policy Implication of the Current Crisis in Insurance Availability and Affordability 33–35 (Washington, D.C. Government Printing Office, Feb. 1986).

plaintiff without a remedy, to us seems totally unfair and out of step with current efforts to allow recovery when the proper case is brought.”

I, too, sympathize with Smith’s tragic situation. However, this court has been faced with similar situations and has applied judicial restraint by declining to expand established principles of the common law merely to provide a remedial measure. [***]

I submit that this court is again confronted with an issue which it is ill-equipped to rule upon. There are too many unanswered questions of social, economic, and legal import, which only the legislature, with its investigative powers and procedures, can determine. Deference to the legislature is especially appropriate due to the legislature’s enactment of the blood shield statute and the impact that any non-identification theory such as market share may have on the blood products industry.

Furthermore, I disagree with the majority’s statement that Hawaii would be “out of step with current efforts to allow recovery when the proper case is brought.” As defendant Cutter Biological notes in its answering brief, since the initial adoption of market share liability in *Sindell*, the highest courts of only four other states have adopted that theory. *Conley v. Boyle Drug Co.*, 570 So.2d 275 (Fla.1990) (DES case); *Hymowitz v. Eli Lilly & Co.*, 73 N.Y.2d 487, cert. denied, 493 U.S. 944, (1989) (DES case); *Collins v. Eli Lilly & Co.*, 116 Wis.2d 166, cert. denied, 469 U.S. 826 (1984) (DES case); *Martin v. Abbott Laboratories*, 102 Wash.2d 581 (1984) (DES case).

Four state supreme courts have rejected the market share theory of liability doctrine: *Smith v. Eli Lilly & Co.*, 137 Ill.2d 222 (1990) (DES case); *Shackil v. Lederle Laboratories*, 116 N.J. 155 (1989) (DPT vaccine case); *Mulcahy v. Eli Lilly & Co.*, 386 N.W.2d 67 (Iowa 1986) (DES case); and *Zafft v. Eli Lilly & Co.*, 676 S.W.2d 241 (Mo.1984) (DES case).

***456** A number of federal courts have also rejected the doctrine: *Tidler v. Eli Lilly & Co.*, 851 F.2d 418 (D.C.Cir.1988) (DES case); *Morton v. Abbott Laboratories*, 538 F.Supp. 593 (M.D.Fla.1982) (DES case); *Mizell v. Eli Lilly & Co.*, 526 F.Supp. 589 (D.S.C.1981) (DES case); *Ryan v. Eli Lilly Co.*, 514 F.Supp. 1004 (D.S.C.1981) (DES case). An empirical study of this issue concluded that “[i]n the last several years decisions in a number of jurisdictions clearly indicate that courts are in no mood to extend that expansionary doctrine [market share liability] any further.” Henderson & Eisenberg, *The Quiet Revolution in Products Liability: An Empirical Study of Legal Change*, 37 U.C.L.A. L. Rev. 479, 492 (1990) (emphasis added).

The Iowa Supreme Court in *Mulcahy v. Eli Lilly & Co.*, 386 N.W.2d 67 (Iowa 1986), aptly states some of the basic reasons why non-identification theories, which eliminate causation as an element of plaintiff’s proof, should not be adopted by the courts:

We acknowledge that plaintiff in a DES case with an unidentified product manufacturer presents an appealing claim for relief. Endeavoring to provide relief, courts have developed theories which in one way or another provided plaintiffs recovery of loss by a kind of court-constructed insurance plan. The result is that manufacturers are required to pay or contribute to payment for injuries which their product may not have caused.

This may or may not be a desirable result. We believe, however, that awarding damages to an admitted innocent party by means of a court-constructed device that places liability on manufacturers who were not proved to have caused the injury involves

social engineering more appropriately within the legislative domain. In order to reach such a determination, three broad policy questions must be answered. One is whether the burden *457 of damages for these injuries should be transferred in a constitutional manner to the industry irrespective of an individual manufacturer's connection with the particular injury. If so, the second question relates to the principles and procedures by which the burden would be transferred. Finally, how do we ascertain the extent of damages to be assessed against each manufacturer? ... Plaintiffs request that we make a substantial departure from our fundamental negligence requirement of proving causation, without previous warning or guidelines. The imposition of liability upon a manufacturer for harm that it may not have caused is the very legal legerdemain, at least by our long held traditional standards, that we believe the courts should avoid unless prior warnings remain unheeded. It is an act more closely identified as a function assigned to the legislature under its power to enact laws.

Mulcahy v. Eli Lilly Co., 386 N.W.2d 67, 75–77 (Iowa 1986).

Leaving plaintiff without a remedy is a harsh result, however, this is not the proper case upon which this court should innovate and radically change the existing law. The application of market share liability in the context of this case would essentially make each defendant manufacturer an insurer of any infected individual who “might” or “could” have used its Factor VIII concentrate. [***] [S]uch a broad imposition of liability is wholly unjustified, unfair, and likely to discourage the future development and sale of blood therapies. The decision of whether such an expansive theory *458 of liability should apply as against manufacturers of blood products is best left to the legislature, which is equipped to address the “Pandora’s box” of questions that the majority acknowledges results by today’s decision.

I submit that the majority is mistaken if its characterization of the record as a “virtual factual vacuum” means that the facts are insufficient, and thus a trial is necessary to develop additional facts in this case. Additional facts will not change the inevitable—that is, Smith’s inability to establish when and how he was infected by the HIV virus, and the fact that information regarding AIDS and the techniques to detect the HIV virus were just being developed during the pertinent period, make it impossible for Smith to prove a standard of care. The majority’s decision now allows all of the parties to proceed to trial, which undoubtedly will result in substantial costs and attorneys’ fees being incurred. However, the expenditure of time and money will be for naught.

Note 1. What is the significance of the court’s declining to adopt alternate liability, enterprise or industry-wide liability and joint and several liability but allowing market share liability? What is the likely effect of that scope? How does the court delimit the scope of market share liability further?

Note 2. The majority opines that “tort law is a continually expanding field.” Yet in judicial opinions declining to expand the scope of tort law, you have likely seen statements to the contrary, or arguments against tort law’s expansion. What justification does the court offer here for the need for such expansion in the case at bar?

Note 3. What are the dissent’s arguments against the application of market share liability? Which opinion is more persuasive to you and why?

Note 4. In a footnote, the majority opinion distinguishes prior case law that found it was a breach of duty that defendant had *not* “use[d] “‘high risk’ questioning as to the specifics of whether the donor was a homosexual [c]. ...the donor, who was clearly identified, would not and did not admit that he was a member of one of the ‘high risk’ groups for AIDS.” At the height of the AIDS epidemic, fears of contagion and misunderstanding about the disease were rampant.

As the COVID-19 pandemic gripped the world in 2020 and 2021, many of the same fears and controversies about infectiousness and contagion vectors arose. A recent essay shared the perspective of one man who drew parallels between the two eras: “From the number of complaints I’m hearing of pandemic fatigue and the widespread resistance to simple precautionary measures such as wearing a mask at the grocery store, it’s clear to me that many people don’t fully appreciate what the gay community has been dealing with for the past 40 years and don’t understand how we survived the AIDS epidemic.”

<https://www.gaystarnews.com/article/how-to-survive-a-pandemic-by-a-gay-man-whos-lived-through-one-before/> (September 25, 2020)

It was almost certainly more difficult socially to come out as bisexual, gay or transgender in the 1980s and AIDS ramped up the challenges by layering on irrational fears of contagion. What do you think of tort cases considering whether a party breached its duty in some way by not asking about a plaintiff’s sexual orientation? Was it understandable—as a public health matter—to hold a party liable for not inquiring if evidence proved that sexual orientation was correlated with higher risk of AIDS? Or should a sense of privacy, propriety, dignity, or some combination of those have been permitted to shield providers and patients from a legal obligation to ask?

Would your answer change if it turned out that the reason for providers not wanting to broach the topic with patients carried legal consequences for patients, such as loss of a job or cancellation of medical insurance, that providers wished to avoid? How about if providers simply wished to avoid asking because they wanted to provide safe (and often free) medical care in the community without patients’ fearing that their sexual orientation would be outed? What if evidence suggested that patients wouldn’t seek testing if they knew they had to reveal their sexual orientation? What is tort law’s responsibility, if any, to take such factors into account when considering what is reasonable under the circumstances?

Expand On Your Understanding – Causation Hypotheticals

Review the following hypotheticals. Turn each card to reveal the answer.

An interactive H5P element has been excluded from this version of the text. You can view it online here: <https://saidtorts2d.lawbooks.cali.org/?p=63#h5p-82>

Chapter 20. Negligence: Proximate Cause

In theory, proximate can be summed up simply: “The *term* “proximate cause” is shorthand for a concept: Injuries have countless causes, and not all should give rise to legal liability.” *CSX Transp., Inc. v. McBride*, 564 U.S. 685, 692 (2011). In practice, scholars, students and lawyers have found it a challenge: ““Proximate cause remains a tangle and a jungle, a palace of mirrors and a maze ... [It] covers a multitude of sins ... [and] is a complex term of highly uncertain meaning under which other rules, doctrines and reasons lie buried.’ ” William L. Prosser, *Proximate Cause in California*. 38 Cal. L. Rev. 369, 375 (1950).

Without adopting an outlook quite as gloomy as the late Dean Prosser’s, it is fair to say that proximate cause can be a confusing area of tort law. The first complexity is in the **interplay with duty** as you have seen already in *Palsgraf*. The second issue is **the relationship to causation in fact** and the risk of conflating the inquiries as you will see in the first case you read in this section, *Camp v. Jiffy Lube*. The third challenge of proximate cause is that **jurisdictions use diverse formulations or tests** and these can vary to some extent. Nonetheless, understanding the main patterns, their interrelationships and their origins in case law proves clarifying. Finally, the last challenge associated with proximate cause is its **unpredictability and malleability**. Because it is expressly infused with normative decisions and policy assessments, it can seem unruly and difficult to categorize or predict.

Questions or Areas of Focus for the Readings

- What does it mean to formulate a “test” for proximate cause? Who does so, and who applies it?
- What is the significance, in practical terms, of differing tests for proximate cause?
- To the extent that proximate cause exists as a policy determination whose primary effect is to limit liability, when should that determination be a question of fact for the jury? Given that duty exists as a gate-keeping (potentially liability-limiting) doctrine as a matter of law for the judge to determine, when *do* cases resolve issues as a function of proximate cause instead of duty, and when *should* they do so, in your view?
- A common way to understand proximate cause cases relative to “garden-variety” (or more ordinary) negligence cases is that the facts usually involve something highly unusual, extraordinary or freakish. The cases select for such fact patterns because one of the issues being litigated, as a question of fact, is the unforeseeability of the nature of the harm, or the extent of it, perhaps, or the unforeseeability of the plaintiff. What do you observe about the kinds of injuries in the cases that follow? What defenses recur and why do you think that is?

Camp v. Jiffy Lube, Superior Court of New Jersey (1998) (309 N.J. Super. 305)

The principal issue on this appeal is whether the trial court properly charged the jury on proximate cause. We conclude the charge was improper. Accordingly, we reverse and remand for a new trial.

The essential facts giving rise to the appeal began on July 13, 1993, when William Camp (plaintiff) left his 1989 Chevrolet at defendant's facility for a routine oil change. After servicing the car, defendant's employees had trouble closing the hood. After *308 several attempts, the employees were able to close the hood. However, when plaintiff picked up the car, no one told him of the difficulty closing the hood. Plaintiff drove about five blocks when the hood suddenly flew open and broke the car's windshield. Plaintiff, contending he sustained bodily injuries as a result, filed a complaint seeking compensatory damages he alleged were proximately caused by defendant's employees' negligence. Plaintiff's wife also sought damages for loss of consortium.

In a liability-only trial, plaintiff contended defendant was negligent because its employees failed to properly shut the hood or because they should have notified or warned him about the problem experienced with shutting the hood but failed to do so. In light of plaintiff's contentions, the trial court instructed the jury on proximate cause.

The court stated:

The burden of proof is on the plaintiff to establish his claim by a preponderance of the evidence.... In this case, the plaintiff, Mr. Camp, has the burden of establishing by a preponderance of the evidence all the facts necessary to prove that the defendant either didn't properly close the hood, or failed to notify him of problems with the hood so he could have taken the proper steps to deal with it.

....

I have indicated to you previously that the term accident in this case does not necessarily mean a multiple or even a one-car collision. The term accident, as used in these jury instructions, means incident. Thus, you are not required to find that an accident occurred, but that an incident occurred. The incident in question is the hood of the plaintiff's car striking the plaintiff's windshield. In this case, the plaintiff contends that the defendant was negligent in failing to properly shut or close the front hood of the car, and/or failing to advise the plaintiff of the problem in shutting or closing the hood of the vehicle so that he could take whatever actions ... he would deem necessary.

Ladies and gentlemen, you have heard me use the term proximate cause.... In order for the plaintiff whose claims you are considering to recover damages, such damages must be proximately caused by the actions or the inactions of the defendant.

By proximate cause is meant that the action or the inaction of the defendant was *the* efficient cause, *the* one that naturally set the other causes in motion, and without which the damages claimed or the injuries claimed would not have resulted. The law requires that the damages chargeable to the defendant must be shown to be the

natural and probable effects of the actions or the inactions of the defendant. [Emphasis added.] *309

The jury returned a verdict against plaintiff by answering “No” to the verdict sheet question, “Was the Defendant, Jiffy Lube, negligent, which negligence was a proximate cause of the incident?” After the trial court denied a motion for a new trial, plaintiff and his wife appealed the ensuing judgment.

They contend the trial court’s proximate cause charge was not only inappropriate given the fact issues for jury resolution but also because the court, in explaining proximate cause, told the jury it meant they had to determine whether defendant’s action or inaction “was *the* efficient cause, *the* one that naturally set the other causes in motion, and without which the damages claimed or the injuries claimed would not have resulted.” [Emphasis added.] We agree the court failed to tailor the proximate cause definition to the facts of the case and compounded that failure by utilizing the definite article “the” in the definition.

Proximate cause is a limitation the common law has placed on an actor’s responsibility for the consequences of the actor’s conduct. It is “a complex term of highly uncertain meaning.” William L. Prosser, *Proximate Cause in California*, 38 *Cal. L. Rev.* 369, 375 (1950) [c]. It requires careful definition in jury charges to avoid misleading the jury. [c]

When instructing a jury on proximate cause, trial courts must distinguish between the routine tort cases and cases where concurrent causes of harm are present. In the former, “ ‘the law requires proof that the result complained of probably would not have occurred “but for” the negligent conduct of the defendant.’” [cc] In the latter, the law requires consideration of the “substantial factor” test. The “but for” standard concentrates on one cause that sets the *310 other causes in motion, while the “substantial factor” test recognizes that “ ‘a tortfeasor will be held answerable if its “negligent conduct was a substantial factor in bringing about the injuries,” even where there are “other intervening causes which were foreseeable or were normal incidents of the risk created.’” [cc] In the latter circumstance, “[a]lthough the law of negligence recognizes that there may be any number of concurrent causes of an injury, [n]evertheless, these acts need not, of themselves, be capable of producing the injury; it is enough if they are a “substantial factor” in bringing it about.’” [cc]

The charge here included no instruction on the “substantial factor” test. Instead, it improvidently focused the jury on the “but for,” or cause that set other causes in action, in an instance where there was evidence of concurrent causes for the harm: the defective hood, the improper shutting of the hood, and the failure to warn about the defective hood. The charge should have been tailored to deal with the concurrent causes projected by the facts in evidence.

The charge compounded the improvident concentration on the need for the jury to concentrate on an exclusive cause that set other causes in motion when it instructed plaintiff was required to establish that defendant’s negligence was *the* proximate cause of the harm that occurred. Emphasis on *the* rather than *a* cause unduly directed the jury’s focus to a “but for” single cause. In *Ellis v. Caprice*, 96 *N.J. Super.* 539, 549 (App. Div.), *certif. denied*, 50 *N.J.* 409 (1967), we reversed a *311 judgment in favor of defendants when the trial court used the definite article “the” in defining proximate cause for the jury. We conclude the same charge mistake here requires reversal.

Nonetheless, defendant argues the charge read as a whole makes the trial court mistake harmless error. Our rationale for rejecting the same argument in *Ellis* is applicable here: “regardless of how well

intentioned the jury may have been, it had no way of knowing which of the two versions represented the correct rule.” [c]. Only an express statement by the trial court that its original proximate cause charge was incorrect would have salvaged the charge. [c] There was no such express statement.

In sum, the proximate cause charge misled the jury on the term’s essential elements in the factual context of the case. Here, plaintiff was entitled to a charge that the jury should consider whether defendant’s failure to give notice, or failure to properly close the hood, was negligence that was a substantial factor in causing the accident giving rise to the injuries. Instead, the jury received a charge that focused on *the* cause for the accident. By placing emphasis on *the* cause, the trial court misdirected the jury’s focus to one that had the potential for placing too much emphasis on the defective latch as the cause and not enough on the failure to give notice or failure to properly close the hood, or both. Consequently, the jury was not sufficiently instructed on the applicable law so that it could perform its function. [c]

Reversed and remanded for a new trial.

Note 1. The court faults the jury instruction for incorrectly using the definite article, “the” rather than the indefinite “a.” In your own words, why does this matter to the outcome in this case?

Note 2. The improper jury instructions also confused the two inquiries of causation. Do you see how?

In re Arbitration Between Polemis and Furness, Withy & Co., Ltd, Court of Appeal (1921) (3 King’s Bench 560)

BANKES, L.J. By a time charter party dated February 21, 1917, the respondents chartered their vessel to the appellants. * * * The vessel was employed by the charterers to carry a cargo to Casablanca in Morocco. The cargo included a quantity of benzine or petrol in cases. While discharging at Casablanca a heavy plank fell into the hold in which the petrol was stowed, and caused an explosion, which set fire to the vessel and completely destroyed her. The owners claimed the value of the vessel from the charterers, alleging that the loss of the vessel was due to the negligence of the charterers’ servants. The charterers contended * * * that the damages claimed were too remote. The claim was referred to arbitration and the arbitrators stated a special case for the opinion of the Court. Their findings of fact are as follows: The arbitrators found that the ship was lost by fire; that the fire arose from a spark igniting the petrol vapor in the hold; that the spark was caused by the falling board coming into contact with some substance in the hold; and that the causing of the spark could not reasonably have been anticipated from the falling of the board, though some damage to the ship might reasonably have been anticipated, and stated the damages at £196,165 1s. 11d. * * * In the present case the arbitrators have found as a fact that the falling of the plank was due to the negligence of the defendants’ servants.

The fire appears to me to have been directly caused by the falling of the plank. Under these circumstances I consider that it is immaterial that the causing of the spark by the falling of the plank could not have been reasonably anticipated. The appellants’ junior counsel sought to draw a distinction between the anticipation of the extent of damage resulting from a negligent act and the anticipation of the type of damage resulting from such an act. He admitted that it could not lie in the mouth of a person

whose negligent act had caused damage to say that he could not reasonably have foreseen the extent of the damage, but he contended that the negligent person was entitled to rely upon the fact that he could not reasonably have anticipated the type of damage which resulted from his negligent act. I do not think that the distinction can be admitted.

Given the breach of duty which constitutes the negligence, and given the damage as a direct result of that negligence, the anticipations of the person whose negligent act has produced the damage appear to me to be irrelevant. I consider that the damages claimed are not too remote. * *

SCRUTTON, L.J. * * * The second defense is that the damage is too remote from the negligence, as it could not be reasonably foreseen as a consequence. * * * [I]f the act would or might probably cause damage, the fact that the damage it in fact causes is not the exact kind of damage one would expect is immaterial, so long as the damage is in fact directly traceable to the negligent act, and not due to the operation of independent causes having no connection with the negligent act, except that they could not avoid its results. Once the act is negligent, the fact that its exact operation was not foreseen is immaterial. * * * In the present case it was negligent in discharging cargo to knock down the planks of the temporary staging, for they might easily cause some damage either to workmen, or cargo, or the ship. The fact that they did directly produce an unexpected result, a spark in an atmosphere of petrol vapor which caused a fire, does not relieve the person who was negligent from the damage which his negligent act directly caused.

For these reasons the experienced arbitrators and the judge appealed from came, in my opinion, to a correct decision, and the appeal must be dismissed with costs.

Note 1. Is the following reasoning from *Polemis* simply restating the *causa causans* principle in *Guille v. Swan*, *supra*, Module 1? “The fact that they did directly produce an unexpected result, a spark in an atmosphere of petrol vapor which caused a fire, does not relieve the person who was negligent from the damage which his negligent act directly caused.” *Polemis* notes that a defendant may sometimes bring a defense on the grounds that “the damage is too remote from the negligence, as it could not be reasonably foreseen as a consequence.” Is this a limit on *causa causans*? What principle is being used to set that limit if so?

Note 2. As you read the pattern jury instruction that follows, keep the reasoning from *Polemis* in mind. Can you see the connection? Although *Polemis* is no longer good law in England where it was decided a century ago, its influence has permeated American case law on the issue of proximate cause.

Tests in the Proximate Cause Analysis

Although many formulations exist, the two most common are the directness test and the foreseeability test. The Restatement has tried to popularize a “scope of the risk” test but it has failed to gain practical traction in the case law whether or not it is influential in other domains. In addition, many jurisdictions add language of substantiality requiring that the plaintiff prove that the defendant’s breach was a substantial factor in the plaintiff’s injuries. As you read examples of jury instructions that illustrate the various formulations of the test, keep causation and proximate cause distinct even where the language appears to conflate the two.

1. “Directness” Test

Washington Pattern Jury Instructions—Civil

WPI 15.01 Proximate Cause—Definition

The term “proximate cause” means a cause which in a direct sequence [*unbroken by any superseding cause,*] produces the [*injury*] [*event*] complained of and without which such [*injury*] [*event*] would not have happened.

[There may be more than one proximate cause of an [*injury*] [*event*].]

WPI 15.01 Proximate Cause—Comment

There have been many attempts to define “proximate cause.” In Washington it has been defined both as a cause which is “natural and proximate,” *Lewis v. Scott*, 54 Wn.2d 851, 857, 341 P.2d 488 (1959), and as a cause which in a “natural and continuous sequence” produces the event, *Cook v. Seidenverg*, 36 Wn.2d 256, 217 P.2d 799 (1950). Some authorities, in an effort to simplify the concept of proximate cause for jurors, have substituted the term “legal cause.” See, e.g., Restatement (Second) of Torts § 9 (1965). However, the “direct sequence” and “but for” definition adopted in this instruction is firmly entrenched in Washington law.

6 Wash. Prac. Wash. Pattern Jury Instr. Civ. WPI 15.01 (7th ed.)

Note 1. Washington state’s jury instruction, above, on proximate cause and related comments, reflects how the profession has synthesized prior cases. But it is also somewhat confusing in that in Washington, “proximate cause” appears to subsume causation in fact (“and without which such [*injury*] [*event*] would not have happened.”) Recall the emphasis in *Camp v. Jiffy Lube*, however, differentiating “the cause” from “a cause.” The next line of the model instruction adds the potential to clarify that: “[t]here may be more than one proximate cause of an [*injury*] [*event*].” This conclusively differentiates but-for causation and proximate causation.

Note 2. New Jersey also adopts a *Polemis*-oriented directness test and it similarly links the two kinds of causation:

“By proximate cause, I refer to a cause that in a **natural and continuous sequence** produces the resulting injuries or losses and **without which** the resulting injuries or losses would not have occurred. A person who admits liability is held responsible for any injuries or losses that result in the ordinary course of events from the happening of the accident. That means that you must find that the resulting injuries or losses to plaintiffs would not have occurred **but for the happening of the accident**. If you find that but for the happening of the accident plaintiffs’ injuries and/or losses would not have occurred, then you should find that the accident was a proximate cause of plaintiff’s injuries and losses.” See Model Jury Charge (Civil), 6.10, “Proximate Cause – General Charge” (rev. Nov. 2019), applied in *Serra-Wenzel v. Rizkalla*, No.

A-5009-18T3, 2020 WL 6123085, at *2 (N.J. Super. Ct. App. Div. Oct. 19, 2020)
(emphasis supplied).

Note 3. Colorado appears to determine causation based on directness and to require foreseeability for proximate cause: “The requirement of but-for causation is satisfied if the negligent conduct in a natural and continued sequence, unbroken by any efficient, intervening cause, produce[s] the result complained of, and without which that result would not have occurred... foreseeability is the touchstone of proximate cause.” *Deines v. Atlas Energy Servs., LLC*, 2021 COA 24, ¶ 12, 13 (internal citations omitted).

Exam tip: So long as you keep the two inquiries of factual and proximate causation distinct, the label or particular test may not matter much. Do remember that it is a mistake to conflate the two inquiries or to skip either one, whatever names they have in a given jurisdiction. Recall that cause-in-fact is descriptive and proximate cause is normative.

Again: cause in fact generally asks *if* cause can be proven; proximate cause assumes that it *can* be factually proven at some level and asks *whether liability should apply* given the circumstances and policy considerations. You can think of proximate cause as an escape valve; it is a doctrine that limits liability even in cases in which duty, breach, cause-in-fact and harm are otherwise met.

2. “Foreseeability” Test

Stewart v. Wild, Supreme Court of Iowa (1923) (196 Iowa 678)

The alleged negligence of the defendant is charged in the petition in the following terms:

“That on or about the 30th day of May, 1920, the plaintiff, her husband, and two sons, were driving in the plaintiff’s automobile on and along the said White Pole road in an easterly direction. That one of the plaintiff’s said sons was driving and operating the plaintiff’s husband’s said automobile in a cautious and careful manner and at a moderate and lawful rate of speed. That when at a point on said highway adjacent to the land owned and operated by the defendant, some hogs, belonging to defendant, which the said defendant had negligently, carelessly, and unlawfully permitted to stray from (upon) said highway, suddenly jumped out of a depression or sunken road, running at right angles with said highway on the west side of said highway, and ran out upon the traveled part of said highway, directly in the path of the plaintiff’s husband’s said automobile. That plaintiff and the other occupants of the said car were unaware of the presence of said hogs until they, the said hogs, ran out from the said depression or sunken road directly in the path of his said automobile. That, although the driver of said car, the plaintiff’s said son, exerted every effort to avoid a collision with the said hogs, he was unable to do so. That one of defendant’s said hogs ran directly under the left front wheel of plaintiff’s husband’s automobile, causing it, the said automobile, to turn turtle and to throw plaintiff and the other occupants of plaintiff’s husband’s said automobile violently to the ground.

That at the time of the said collision, the defendant was standing in the barnyard of the said farm, east of the said highway. That just as the plaintiff’s husband’s automobile reached the point at, or near, said

depression or sunken road, the defendant called the said hogs. That the said hogs jumped up and ran out upon the traveled part of the said highway, in the path of the plaintiff's husband's said automobile, in response to the defendant's said call. That defendant knew full well, or should have known, that the said hogs would jump out of the said depression or sunken road in response to his said call, and run out in the traveled part of the highway directly in the path of the said automobile.

That the defendant above named was guilty of negligence and carelessness in connection with the matter of said hogs being upon said public roadway, in that said defendant did fail to restrain said hogs from running at large and did fail to restrain said hogs from going upon public roads for travel or driving, and in that said defendant did fail to keep the said hogs under his immediate care and efficient control, as provided by section 2314 of the Code of Iowa 1897.

That defendant was guilty of carelessness and negligence, in that, in addition to failing to restrain said hogs from going upon a public roadway, he did commit an affirmative act of negligence and carelessness, in that he did call his hogs from the other side of the roadway from where he was located, at a time when automobiles, and particularly when the automobile in which plaintiff was riding, was passing along said roadway, which fact was known to defendant, or, in the exercise of reasonable care, should have been known to defendant, thus causing said hogs to quickly and suddenly run upon and in front of the automobile in which plaintiff was riding, and causing said automobile to turn turtle as hereinbefore stated."

***268** The demurrer to the foregoing was predicated upon the three following grounds:

1. It appears from the plaintiff's petition that **no negligence on defendant's part**, of which plaintiff has a right to complain, **was the proximate cause of plaintiff's injury**, if any she suffered.
2. Even if the matters and things set forth in plaintiff's petition were true, the fact that some of defendant's hogs were on the public highway, if such were a fact, does not render him liable for automobile accidents or make him an insurer of the safety of persons traveling along the public highway, so far as a collision between a pig and an automobile is concerned.
3. The matters and things set out in plaintiff's petition as negligence or as improper or unlawful acts on the part of defendant are not such matters and things as to enable the plaintiff to base a cause of action thereon against the defendant or to entitle her to recover against him, because **the mere escape of hogs from an inclosure is not negligence**, and *a collision between a hog and an automobile on a public highway is not such a thing as defendant could or would be bound to anticipate*, if his hogs should escape from an inclosure on to the public highway."

The argument of the appellee [hog owner] in support of the foregoing grounds of demurrer is predicated largely upon the twofold assumption:

- (1) That the action is one for statutory damages under sections 2313 and 2314 of the Code.
- (2) That such statute has no application to the rights of a traveler upon the highway, and that it imposes upon the owner of swine no duty with reference to such highway travel.

The record indicates that such was the controlling reason for the sustaining of the demurrer. We note first, therefore, that this conception of the nature of the action is an erroneous one. The petition discloses an ordinary action at law for damages for negligence. In such an action, it is always incumbent upon the plaintiff to plead and to prove the alleged negligence. Negligence is the breach of some duty,

imposed either by common law or by statute upon the offending party. If the duty be imposed, then a breach of it is actionable, if it result proximately in injury to another; and this is equally true whether the duty be imposed by common law or by statute.

The petition charges two negligences:

- (1) That the defendant negligently permitted his hogs to run at large upon the highway.
- (2) That he was affirmatively negligent in calling his hogs under the circumstances existing at the time of such calling.

For the moment we shall ignore the latter charge, and consider only whether the first was a sufficient allegation of negligence. At common law, it was the duty of the defendant to restrain his hogs from running at large. He had the common right of the public to drive them upon the highway while in charge of a caretaker. He had no right to permit them to run upon the highway without a caretaker. This rule of the common law has not been abridged by our statute. On the contrary, it has been expressly confirmed. Section 2314 expressly prohibits the owner of swine from permitting the same to run at large at any time. It also defines the phrase "running at large" as follows:

"But stock shall not be considered as running at large so long as it is upon unimproved lands and under the immediate care and efficient control of the owner, or upon the public roads for travel or driving thereon under like care and control."

The necessary effect of this statute is both to recognize and to impose upon the owner of hogs the legal duty to restrain them from running at large, either upon the lands of another, or upon the public highway. [***]

We hold, therefore, at this point that the allegation that the defendant negligently permitted his hogs to run at large upon the highway is a sufficient allegation of negligence for the purpose of a demurrer. Whether it should have been made more specific is a question not involved in a consideration of the demurrer. [***]

It is urged by appellee that the alleged negligence of the defendant was not the proximate cause of the injury suffered, in that the accidental collision of the hog with the plaintiff's automobile was an accident or event that the owner of the hog could not have anticipated as a probable consequence of his negligence. [***] On the general proposition [***] cited by the appellee, we are unable to give our assent. It is the fundamental law of the highway that it is subject to the use of the traveling public, and that it must be kept free from such obstructions as are not incident to its use for travel. Whatever endangers travel thereon, and which is not incident to the lawful use or care of the highway, becomes ordinarily a nuisance and a public peril.

In the days of the ox-drawn vehicle, it may be conceded that the presence of a hog upon the highway would not present any imminent danger of a collision with the vehicle. In the later day of the swifter moving horsedrawn vehicle, the presence of a hog at large became an increased danger, though more readily avoidable than in the still later day of the motor vehicle. In these days of general travel by motor vehicle, we see no room for saying, as a matter of law, that the presence of a hog at large upon the highway does not suggest danger of collision with traveling vehicles. If it could be said, as a matter of law, that the instincts of a hog stimulate him to an avoidance and escape from an approaching vehicle, there might be some room for debate. But it could as well be said, and doubtless more plausibly, that

by the universal verdict of general observation his instincts and natural tendencies are in the other direction, and that he will more likely, if not certainly, pass in front of a moving vehicle at whatever time or place it comes within the short radius of his locomotion. Ordinarily the question of proximate cause is one of fact for the jury, and we are not now dealing with the weight of evidence or with expert opinion as to the habits or tendencies of the hog. The liability of owners for damages for a collision of vehicles with stock, unlawfully running at large upon the highway, has heretofore been recognized by us quite as a matter of course without challenge by the defending litigant. [cc]

In the latter case we said:

“The statute to which this allegation has reference [meaning the allegation of the petition] does not involve the doctrine of common-law negligence, upon which the liability in the instant case must be and is predicated.”

We hold at this point that it cannot be said as a matter of law that a collision between a vehicle and a hog, unlawfully running at large upon the highway, is an event too remote to be deemed as the proximate result of defendant’s negligence, if any.

One of the grounds of the demurrer was that the defendant is not liable for a mere escape of his hogs from the inclosure in which they were confined, and that such escape of the hogs did not constitute negligence on the part of the owner; and this point is pressed in argument here. There is nothing in the allegations of the petition to which this ground of the demurrer is apropos. ... Upon trial, it will be incumbent upon the plaintiff to prove the negligence, and it will be open to the defendant to negative the same, both by affirmative as well as negative evidence. Proof that the hogs were running at large would doubtless be presumptive evidence of defendant’s breach of statutory duty, and therefore of negligence. What circumstances might be deemed as sufficient to excuse the defendant and to render him free from fault is a question not involved in the demurrer.

[***] It is our conclusion that the demurrer should have been overruled, and that the *270 learned trial judge erred in ruling otherwise. The judgment below is accordingly reversed, and the cause is remanded accordingly.

Note 1. What exactly is the negligence alleged (and on what basis is it proven)?

Note 2. In your view, is this case one that should be resolved on grounds of duty, or proximate cause? Would it matter to your determination what the jurisdiction looked like, socioculturally or agriculturally?

Note 3. The test for proximate cause is not expressly stated in this case but the defendant’s argument raises a lack of foreseeability argument in vain: “the accidental collision of the hog with the plaintiff’s automobile was an accident or event that the owner of the hog could not have anticipated as a probable consequence of his negligence.”

Note 4. Many states use some version of foreseeability in their proximate cause analysis. Consider this example from Utah:

Under Utah law, “[p]roximate cause is that cause which, in natural and continuous sequence (unbroken by an efficient intervening cause), produces the injury and without

which the result would not have occurred. It is the efficient cause—the one that necessarily sets in operation the factors that accomplish the injury ...

Under Utah law, “[w]hat is necessary to meet the test of negligence and proximate cause is that it be reasonably foreseeable, not that the particular accident would occur, but only that there is a likelihood of an occurrence of the same general nature.” [c]. The defendant need not predict the exact injury that flows from its negligence so long as the general nature of the injury is foreseeable.”

Jacobs-Peterson v. United States, 219 F. Supp. 3d 1091, 1096 (D. Utah 2016)

The next case draws more explicitly on the concept of foreseeability and illustrates how it can operate in both duty and proximate cause analysis.

Chapter 21. Negligence: Foreseeability in Duty and Proximate Cause Analysis (Socratic Script)

Warning: The next case features a pretty gory fact pattern. Steel yourselves.

Zokhrabov v. Park, Circuit Court of Illinois (2010) (2010 WL 7198225) (Ill.Cir.Ct.) (Trial Order)

*1 These matters come before the court on plaintiff Gayane Zokhrabov's motion for partial summary judgment and defendant Jeung-Hee Park's cross-motion for summary judgment pursuant to 735 ILCS 5/2-1010. This case arises out of a September 13, 2008 incident wherein an Amtrak train struck and killed Hiroyuki Joho ("decedent"), defendant's son. The impact of the collision caused decedent's body to fly through the air and hit plaintiff, causing her multiple injuries. Plaintiff filed a two-count complaint against decedent's estate (count I) and Northeast Regional Commuter RR Corporation (count II). Count I sounds in negligence and count II has been voluntarily dismissed.

[Editor's note, on appeal, the court provided a fuller statement of facts, which I include here.]

Hiroyuki Joho was killed when he was struck by an Amtrak train at the Edgebrook Metra station at Lehigh and Devon Avenues in Chicago. Joho's accident occurred just before 8 a.m. on Saturday, September 13, 2008, when the 18-year-old man was crossing in a designated crosswalk from the eastside passenger platform where Metra commuter trains arrive from Chicago, to the westside passenger *1038 platform where Metra commuter trains depart toward Chicago. Joho was about five minutes early for the next scheduled Metra departure to Chicago. The sky was overcast and it was raining heavily as he proceeded west across the double set of tracks, holding an open, black umbrella over his head and a computer bag on a strap across his shoulder. The Metra station was not a destination for the Amtrak train that was traveling south at 73 miles an hour, and the engineer in the bright blue locomotive maintained speed, but sounded a whistle which triggered automatic flashing headlamps. Witnesses, nonetheless, disagreed as to whether Joho realized the train was approaching. He was smiling at the commuters standing on the southbound platform when the train hit him. A large part of his body was propelled about 100 feet onto the southbound platform where it struck 58-year-old Gayane Zokhrabov from behind, knocking her to the ground. She sustained a shoulder injury, a leg fracture, and a wrist fracture. (963 N.E.2d 1035) [***]

Plaintiff moves for summary judgment on the issues of negligence and proximate causation Defendant moves for summary judgment on the issue of duty. Plaintiff alleges that defendant's decedent owed plaintiff a duty of reasonable and ordinary care, and breached that duty when he:

- (a) carelessly and negligently failed to keep a proper lookout for approaching trains; or
- (b) carelessly and negligently ran in the path of an approaching train; or
- (c) carelessly and negligently failed to yield the right of way to approaching trains.

She also attempts to impose a legal duty on decedent by citing to 625 ILCS 5/11-11-1011(c), which states:

No pedestrian shall enter, remain upon or traverse over a railroad grade crossing or pedestrian walkway crossing a railroad track when an audible bell or clearly visible electric or mechanical signal device is operational giving warning of the presence, approach, passage, or departure of a railroad train.

[***] *2 To determine the existence of a duty, the court looks to the “relationship between defendant and plaintiff, the likelihood of injury, the magnitude of guarding against the injuries, and the consequences of placing that burden on defendant.” [c] However, “even if an injury was foreseeable, foreseeability alone will not create a legal duty.” Establishing legal duty “requires more than a mere possibility of occurrence.” *Cunis v. Brennan*, 56 Ill.2d 372, 376 (1974). One cannot be “expected to guard against harm from events which are not reasonably to be anticipated at all, or are so unlikely to occur that the risk, although recognizable, would commonly be disregarded.” *Id.* An “actor’s conduct may be held not to be a legal cause of harm to another where after the event and looking back from the harm to the actor’s negligent conduct, it appears to the court highly extraordinary that it should have brought about the harm.” *Id.* The court must be careful not to examine “what may appear through exercise of hindsight” and must “consider what was apparent to the defendant at the time of his now complained of conduct.” *Id.* When an “injury results from freakish, bizarre or fantastic circumstances, no duty exists and no negligence claim can be asserted for injuries that were not reasonably foreseeable.” [c]

“Statutes and ordinances designed to protect human life or property establish the standard of conduct required of a reasonable person.” [c] These types of law “fix the measure of legal duty.” *Id.* “A party injured by such a violation may recover only by showing that the violation proximately caused his injury and the statute or ordinance was intended to protect a class of persons to which he belongs from the kind of injury that he suffered.” [c]

In *Cunis, supra*, plaintiff was involved in a collision and was injured when he was thrown from his car and landed on a pipe in a parkway 30 feet away. He sued, *inter alia*, the Village of LaGrange which owned the parkway. After discussing statistics showing the frequency with which passengers were ejected from cars after collisions, the Supreme Court nevertheless found that no duty was owed because this accident was not reasonably foreseeable. Specifically, the court stated:

The circumstance here of the plaintiff’s being thrown 30 feet upon the collision with a third person’s automobile and having his leg impaled upon the pipe was tragically bizarre and may be unique. We hold that the remote possibility of the occurrence did not give rise to a legal duty on the part of the Village to the plaintiff to protect against his injury. [c]

The instant case is similar. The circumstance that a portion of decedent’s body would be thrown 100 feet into the plaintiff is “tragically bizarre”. In fact, this outcome was even less foreseeable to decedent as his negligently crossed in front of the train than was that in *Cunis*. Also, plaintiff is not in the class of those persons who were intended to be protected by 625 ILCS 5/11-1011(c). Section 11-1011 is intended to protect pedestrians from being struck by a train.

Accordingly, defendant's Cross-Motion for Summary Judgment is GRANTED, and plaintiff's Motion for Partial Summary Judgment is DENIED. This order is final and disposes of this case.

**Zokhrabov v. Park, Appellate Court of Illinois (2011)
(963 N.E.2d 1035)**

[***] It is axiomatic that pedestrians on or near active train tracks are at great risk of suffering severe, even fatal, injuries. This court recently held that the personal danger posed by stepping in front of a moving train is an open and obvious danger. *Park v. Northeast Illinois Regional Commuter R.R. Corp.*, 2011 IL App (1st) 101283, 960 N.E.2d 764, 771. The law generally assumes *1039 that persons who encounter obvious, inherently dangerous conditions will take care to avoid the danger. *Park*, 960 N.E.2d at 771. “The open and obvious nature of the condition itself gives caution * * *; people are expected to appreciate and avoid obvious risks.” [cc] [***] Numerous cases indicate that death or great bodily harm is the likely outcome of failing to exercise due care when walking on or near active train tracks. [cc] [***] In addition to these cases indicating that active trains pose an open and *1040 obvious danger to pedestrians, there is an Illinois statute regarding pedestrian rights and duties which states: “No pedestrian shall enter, remain upon or traverse over a railroad grade crossing or pedestrian walkway crossing a railroad track when an audible bell or clearly visible electric or mechanical signal device is operational giving warning of the presence, approach, passage, or departure of a railroad train [or railroad track equipment].” 625 ILCS 5/11–1011(c) (West 2006).

Breach of a statute enacted to protect human life or property, which is the obvious purpose of this statute, is an indication that a person has acted with less than reasonable care. [c] [***] Thus, the precedent and statute indicate that Joho failed to act with due regard for his own safety and self-preservation. The record indicates the Amtrak engineer triggered an audible warning whistle and flashing headlamps before proceeding through the Edgebrook Metra station. Even if Joho mistook the Amtrak train which was not stopping at the station for the Metra train which he intended to board, the record indicates he failed to exercise reasonable care for his own safety when he failed to look down the train tracks before attempting to cross the tracks in front of an approaching train.

The question we must answer is whether Joho owed a duty of care to Zokhrabov as he approached and entered the active Edgebrook station and she stood down the tracks in the waiting area designated for intended passengers. [***]

One justification for imposing liability for negligent conduct that causes physical harm is corrective justice; imposing liability remedies an injustice done by the defendant to the plaintiff. An actor who permits conduct to impose a risk of physical harm on others that exceeds the burden the actor would bear in avoiding the risk impermissibly ranks personal interests ahead of others. This, in turn, violates an ethical norm of equal consideration when imposing risks on others. Imposing liability remedies this violation.

Restatement (Third) of Torts § 6, cmt. d (2010).

Another justification for imposing liability for negligence is to give actors appropriate incentives to engage in safe conduct. The actor's adoption of appropriate precautions improves social welfare and thereby advances broad economic goals.

Id.

***1041** Therefore, when determining whether a duty of care exists in a particular set of circumstances, an Illinois court will consider, among other factors, the reasonable foreseeability that the defendant's conduct may injure another. *Colonial Inn Motor Lodge, Inc. v. Gay*, 288 Ill.App.3d 32, 40 (1997). The court's other considerations in a duty analysis include the reasonable likelihood of an injury, the magnitude of the burden imposed by guarding against the harm, and the consequences of placing this burden on the defendant. *Colonial Inn*, 288 Ill.App.3d at 40.

It is a "well-established principle of tort law that the particular manner or method by which a plaintiff is injured is irrelevant to a determination of the [defendant's] liability for negligence." *Nelson v. Commonwealth Edison Co.*, 124 Ill.App.3d 655, 660 (1984). The existence of a duty depends on whether there was a potential for initial contact with and thus an injury to the plaintiff, meaning that the plaintiff was a foreseeable plaintiff. *Colonial Inn*, 288 Ill.App.3d at 42 ("Focusing on the potential for injury rather than on the specifics of the harm that did occur, we find the duty problem is relatively simple."). "It is generally accepted that where the plaintiff's injury resulted from the same physical forces whose existence required the exercise of greater care than was displayed and were of the same general sort expectable, unforeseeability of the exact developments and of the extent of loss will not limit liability." *Nelson*, 124 Ill.App.3d at 661. "For example, if a ship owner fails to clean petroleum out of his oil barge moored at a dock, he has created an undue risk of harm through fire or explosion. The fact that a fire is ignited by the unusual event of lightning striking the barge does not relieve the ship owner from liability to foreseeable plaintiffs who are injured." *Nelson*, 124 Ill.App.3d at 661. Thus, a foreseeable injury, even through unforeseen means, is actionable.

However, in a duty analysis, we must take care to differentiate between "two distinct problems in negligence theory," the first being the foreseeable injury resulting from unforeseen means, which is an actionable injury, and the second being the unforeseen plaintiff, who is not owed a duty of care. *Nelson*, 124 Ill.App.3d at 660. Furthermore, while the foreseeability of injury to the particular plaintiff is properly considered in a duty analysis, the foreseeability of the particular injury or damages are more appropriately considered in determining the factual issue of proximate causation (*Colonial Inn*, 288 Ill.App.3d at 40–41), and we must differentiate between these two circumstances in order to properly apply the "foreseeability" test (*Nelson*, 124 Ill.App.3d at 662). In this case, the trial judge concluded it was not reasonably foreseeable and was instead tragically bizarre that when Joho crossed in front of the oncoming Amtrak train in Edgebrook he would be struck and thrown 100 feet to where Zokhrabov stood on the Metra customer platform.

The trial judge based his conclusions on *Cunis v. Brennan*, 56 Ill.2d 372 (1974), which involved a two-car collision in suburban La Grange, Illinois, in which a passenger was ejected and thrown 30 feet to the public parkway, where his leg was impaled on an abandoned municipal drain pipe, necessitating amputation of the limb. ***1042** *Id.* at 373. The passenger alleged the municipality was negligent in leaving the broken drain there. *Id.* at 374. The likelihood that the collision would cause the passenger to be ejected and propelled 30 feet to the exact location of a broken pipe that was 4.5 feet from one curb and 5.5 feet from the other, and then impaled, seemed very remote and led the trial and supreme

courts to conclude that the circumstances were “tragically bizarre” and possibly even a “unique” outcome. *Id.* at 377. The fact that the “misplaced drainpipe would cause *any* injury to someone riding in a car 30 feet away was an example of “ ‘the freakish and the fantastic,’ ” for which the village was not liable. (Emphasis in original.) [c] (quoting *Cunis*, 56 Ill.2d at 376 (quoting William Prosser, *Palsgraf* Revisited, 52 Mich. L. Rev. 1, 27 (1953))).

The passenger’s injury would appear to involve many variables, including the speed and weight of the two vehicles, the angle of their collision, the weather conditions, the extent and direction of any evasive maneuvers, and the passenger’s height, weight, and position within the vehicle, as well as whether he was wearing a seatbelt. The supreme court affirmed the trial judge’s ruling that the injured passenger had not alleged what occurred was reasonably foreseeable and therefore a basis for holding the Village of La Grange liable for negligently breaching its duty of care. *Cunis*, 56 Ill.2d at 378.

Thus, *Cunis* may be cited generally for the proposition that there is no duty to anticipate and prevent injuries that occur due to unusual and extraordinary circumstances. We do not find *Cunis* helpful here, however. The two-car collision, ejection, and impalement in La Grange bear little similarity to the train-pedestrian collision in Edgebrook that caused a third, unconnected person to be struck and injured. In contrast to the complex and unique combination of factors in La Grange, the potential outcome of Joho’s conduct in Edgebrook appears to be relatively limited, since the path of the train was fixed, the pedestrian crosswalk was marked, the train ran within the established speed limit, its speed, weight, and force grossly exceeded any pedestrian’s, and commuters were congregating to the side of the train tracks for the next scheduled public departure.

Cunis does not inform us about the factual circumstances in Edgebrook—it does not indicate that what occurred at the train station was such an unusual and extraordinary combination of facts that Joho could not reasonably foresee the potential for causing injury to the waiting passengers when he decided to cross the tracks. *Cunis* does not suggest that what occurred in Edgebrook was similarly “freakish” “fantastic” or tragically bizarre. *Cunis*, 56 Ill.2d 372.

There are no reported cases we have found in which a pedestrian who was struck and injured by a flying body sued the deceased person’s estate. There are a few cases in which a pedestrian was struck by a train or car and flung into another person. In these cases, however, the injured person sued the railroad or automobile driver. We do not find these opinions particularly helpful because they concern the alleged negligent operation of a rail yard or a train or other vehicle, which is not analogous to Joho’s alleged negligence as a pedestrian traversing train tracks. [cc] Thus, there are a few reported cases involving flying pedestrians, but none of them are analogous to Joho’s conduct with respect to Zokhrabov.

Accordingly, rather than relying on cases which are factually and procedurally dissimilar, we apply a traditional duty analysis to determine whether Zokhrabov was a foreseeable plaintiff and thus owed a duty of care. *Colonial Inn Motor Lodge, Inc. v. Gay*, 680 N.E.2d 407 at 414 (1997) (a duty of care exists if there was a potential for initial contact with and thus an injury to the plaintiff, meaning that the plaintiff was a foreseeable plaintiff; “[f]ocusing on the potential for injury rather than on the specifics of the harm that did occur [makes a duty analysis] relatively simple”).

At the outset of this opinion, we cited cases regarding pedestrians struck by trains and a statute regarding pedestrian rights and safety as indicators that Joho acted without due regard for his own person and self-preservation in the active train station. We reiterate that the potential outcome of his

conduct appears to be relatively limited, since the path of the train was fixed, the pedestrian crosswalk was marked, the train ran within the established speed limit, its speed, weight, and force grossly exceeded any pedestrian's, and commuters were congregating to the side of the train tracks for the next scheduled public departure. Accordingly, we further find that it was reasonably foreseeable that the onrushing Amtrak train would strike, kill, and fling his body down the tracks and onto the passenger platform where Zokhrabov was waiting for the next scheduled Metra departure. We find that the trial court erred in concluding that Joho could not reasonably foresee that his negligence in the active train station would cause injury to someone standing in the passenger waiting area.

Continuing with the four elements of a duty analysis, we find that the reasonable likelihood of injury occurring was great given the relative force of the approaching Amtrak train, that the magnitude of the burden imposed by guarding against the harm was insignificant, since Joho needed only to pause, look down the tracks, and then time his crossing accordingly, and that the consequences of placing the burden on Joho would have been minimal.

***1045** We, therefore, find that the trial judge erred in holding that the defendant owed the plaintiff no duty of care. We reverse the entry of summary judgment as to duty and remand Zokhrabov's case for further proceedings. We express no opinion regarding the additional elements of her negligence action, including breach, proximate causation, and damages, which are issues usually decided by a jury. Reversed and remanded.

Note 1. The appellate court remands to allow the case to proceed to a jury on the several issues, including proximate causation, but it is notable that duty *failed* to limit liability here. What factors would you consider in deciding whether Joho had breached his duty to Zokhrabov? What sorts of facts, if true, would cause you to limit the liability of his estate to compensate Zokhrabov for her injuries?

Note 2. How would Justices Cardozo and Andrews in *Palsgraf* each have resolved this case, do you think?

Expand On Your Understanding – Socratic Script: Zokhrabov v. Park

Question 1. What are plaintiff's and defendant's main arguments, respectively?

An interactive H5P element has been excluded from this version of the text. You can view it online here: <https://saidtorts2d.lawbooks.cali.org/?p=67#h5p-83>

Question 2. How does the court frame the central legal question?

An interactive H5P element has been excluded from this version of the text. You can view it online here: <https://saidtorts2d.lawbooks.cali.org/?p=67#h5p-84>

Question 3. How does the court conduct its duty analysis? Does its analysis strike you as familiar from another context?

An interactive H5P element has been excluded from this version of the text. You can view it online here: <https://saidtorts2d.lawbooks.cali.org/?p=67#h5p-85>

Question 4. For what purpose does the court discuss the open and obvious doctrine?

An interactive H5P element has been excluded from this version of the text. You can view it online here: <https://saidtorts2d.lawbooks.cali.org/?p=67#h5p-86>

Question 5. Why does the court refuse to apply negligence per se?

An interactive H5P element has been excluded from this version of the text. You can view it online here: <https://saidtorts2d.lawbooks.cali.org/?p=67#h5p-87>

Question 6. How does the court frame its reasoning in terms of tort law's purposes?

An interactive H5P element has been excluded from this version of the text. You can view it online here: <https://saidtorts2d.lawbooks.cali.org/?p=67#h5p-88>

Check Your Understanding (3-8)

Read this excerpt from a recent case in Connecticut reviewing its jury instructions and answer the questions below.

Connecticut Pattern Jury Instruction: Proximate Cause

Once you've gotten past factual causation, you need to address proximate cause. Proximate cause means that there must be a sufficient causal connection between the act or omission alleged, and any injury or damage sustained by the plaintiff.

An act or omission is a proximate cause if it was a substantial factor in bringing about or actually causing the injury. That is, if the injury or damage was a direct result, or a reasonable and probable consequence of the defendant's act or omission, it was proximately caused by such an act or omission.

In other words, if an act had such an effect in producing the injury that reasonable persons would regard it as being a cause of the injury, then the act or omission is a proximate cause. In order to recover damages for any injury, the plaintiff must show by a preponderance of the evidence that such injury would not have occurred without the negligence of the defendant.

If you find that the plaintiff complains about an injury which would have occurred even in the absence of the defendant's conduct, or is not causally connected to this accident, you must find that the defendant did not proximately cause that injury.

Under the definitions I have given you, negligent conduct can be a proximate cause of an injury, if it is not the only cause, or even the most significant cause of the injury, provided it contributes materially to the production of the injury, and thus is a substantial factor in bringing it about.

Therefore, when a defendant's negligence combines together with one or more other causes to produce an injury, such negligence is a proximate cause of the injury if its contribution to the production of the injury, in comparison to all other causes, is material or substantial.

Question 1. What test does Connecticut appear to apply? You might take stock of how it has been modified, too.

An interactive H5P element has been excluded from this version of the text. You can view it online here: <https://saidtorts2d.lawbooks.cali.org/?p=67#h5p-89>

Question 2. The proximate cause jury instructions contain references to causation in fact (as many jury instructions do, combining both prongs in negligence’s causation analysis). Can you see where that language arises?

An interactive H5P element has been excluded from this version of the text. You can view it online here: <https://saidtorts2d.lawbooks.cali.org/?p=67#h5p-90>

Question 3. Setting aside jurisdictional differences, proximate cause is generally satisfied when:

An interactive H5P element has been excluded from this version of the text. You can view it online here: <https://saidtorts2d.lawbooks.cali.org/?p=67#h5p-91>

Question 4. Complete the sentence: The question of proximate cause goes to the jury _____.

An interactive H5P element has been excluded from this version of the text. You can view it online here: <https://saidtorts2d.lawbooks.cali.org/?p=67#h5p-92>

The next case involves an intersection of three areas or doctrines: **proximate cause**, **res ipsa loquitur** and **the rescue rule**. It provides helpful practice in seeing how courts apply each to the facts, often in light of conflicting priorities set out in the given doctrines. It may be helpful to know that professional rescuers and public-safety responders are barred, in many jurisdictions, from bringing a negligence action against a tortfeasor whose alleged conduct is the impetus for the rescue or bringing the officer to the scene of emergency where they were injured. Such rescuers cannot usually recover in negligence for liability for their injuries. The rationale is either that they may recover for injuries in workers’ compensation or that they assumed the risk (and perhaps higher pay) associated with this line of employment. This is often known as the **firefighter rule** (or the professional rescuer rule). Some states have eliminated the Firefighter’s Rule entirely, finding it to be an outdated concept that is unfair to emergency responders—for instance, Oregon abolished the Firefighter’s Rule by case law, see *Christensen v. Murphy*, 296 Or. 610 (Or., 1982), and New Jersey abolished it by statute, see New Jersey Public Statutes 2A:62A-21.

Clinkscales v. Nelson Securities, Supreme Court of Iowa (2005) (697 N.W.2d 836)

“Danger invites rescue.”¹²² A marine out for a drink at a Davenport bar rushed to the scene of a gas leak at a grill on the premises. While attempting to turn off two propane gas tanks, a grease fire reignited and he was badly burned. The district court dismissed the marine’s negligence claim against the bar. The court held as a matter of law the marine was solely to blame for his injuries. The court of appeals affirmed. Because a jury could find the bar’s negligence proximately caused the marine’s rescue attempt and injuries, we reverse the district court, vacate the court of appeals, and remand for a trial on the merits.

I. Facts

Late one Friday afternoon in the summer of 2002, James Clinkscales went to The Gallery Lounge, a Davenport pub. Approximately fifty people were there. Clinkscales, an active-duty marine in town as a recruiter, stationed himself at the bar next to a blonde woman known only as “Dimples.” The two began to share a pitcher of beer together.

On Fridays in the summer, The Gallery regularly grilled hamburgers outside and served them to its customers. The grill stood directly outside of the bar on a patio ten feet away from where Clinkscales and Dimples sat. Two tanks of propane gas placed underneath the grill fueled it. The grill was custom-made and large enough to grill twenty burgers at a time.

The Gallery employed Joe Moser to grill the burgers. The first batch of burgers Moser placed on the grill that evening were particularly greasy. When Moser flipped them over, a fire flared up on the grill. Moser did not consider this to be a problem. All of a sudden, however, Moser heard something abnormal—“a pop and a hiss.” A ball of fire erupted underneath the grill and engulfed the propane tanks.

Caroline Nelson co-owns The Gallery with her husband and regularly works there. When the fire started Nelson was standing at the patio door. Moser told Nelson to get a fire extinguisher. Nelson and Moser testified Nelson and other Gallery employees made general announcements to the patrons to leave and then one employee called the fire department. Clinkscales testified he was alerted to the fire when he saw Nelson come into the bar looking for a fire extinguisher, but did not believe Nelson said anything to him or anybody else about what was happening.

Nelson came back outside with a fire extinguisher and gave it to a patron. The patron extinguished the flame, and Moser managed to turn the knobs on the grill to *840 “the off” position. Moser could still smell gas escaping from the tanks, however, and Moser said aloud that he wanted to shut the tanks off. Moser pulled the grill away from a wall to access the tanks, but he found the valves were too hot to touch. There were customers in the patio and adjacent bar. Clinkscales came out to the patio and asked a man holding a fire extinguisher if anyone had turned the gas off. The man told Clinkscales the handle was too hot.

¹²² Wagner v. Int’l Ry., 232 N.Y. 176, 133 N.E. 437, 437 (1921) (Cardozo, J.).

Clinkscales, who had received extensive training in fire suppression in the military, recognized the situation was “very dangerous.” Clinkscales took off his shirt, wrapped it around one of his hands, and turned the gas off. No one asked Clinkscales to do so. He reacted instinctively:

[I]t’s like running after a kid when he runs into the street, you don’t think about it, that there’s a car coming, you just try to grab the child, and, you know, hope for the best. You could get killed doing it, but you just do it.

As Clinkscales was turning off the gas, the fire flared up. Clinkscales was burned on his face, neck, chest, arms, and legs.

Skin hanging from his arms, Clinkscales continued his rescue efforts by helping a frightened young woman in the patio over a fence. A frequent patron of the bar, a man named Norm, took Clinkscales to the hospital just as the fire department arrived.

II. Prior Proceedings

Clinkscales sued The Gallery for negligence. He claimed The Gallery owed him a duty of care as a business invitee. Clinkscales alleged The Gallery was specifically negligent because it (1) failed to properly design, manufacture, maintain, and operate the grill; (2) did not adequately train its employees in the use and maintenance of the grill; (3) did not have enough fire-suppression equipment and did not properly use the fire extinguishers it did have; and (4) did not have emergency procedures in place necessary to protect its customers. In the alternative, Clinkscales also pled *res ipsa loquitur* to show general negligence. Clinkscales contended that even if he could not prove the precise cause of the mishap, the defendants had exclusive control over the instrumentalities involved in the fire. [fn]

The defendants filed a motion for summary judgment, which the district court granted. As a matter of law the district court found employees of The Gallery told Clinkscales to evacuate the premises; there was no evidence there was imminent risk to life when he turned off the gas; and “a reasonable person would not determine that the benefits of approaching a fire outweigh the risk of being seriously burned or injured.” The district court ruled the defendants were not liable because (1) Clinkscales’s injuries were caused by a known and obvious danger and (2) the defendants’ alleged negligence was not the proximate cause of Clinkscales’s injuries. The court also concluded *res ipsa loquitur* was not applicable because grease fires can occur without negligence. The court of appeals affirmed. It declined to apply the rescue doctrine and held, as a matter of law, Clinkscales “suffers from a self-inflicted wound.”

III. Principles of Review [omitted]

IV. The Merits

A. The Rescue Doctrine

The rescue doctrine was forged at common law. It involves heroic people doing heroic things. The late Justice Cardozo aptly summarized the commonsense observations about human nature that led to the doctrine’s widespread recognition across this nation when he wrote:

Danger invites rescue. The cry of distress is the summons to relief. The law does not ignore these reactions of the mind in tracing conduct to its consequences. It recognizes them as normal. It places their effects within the range of the natural and probable. The wrong that imperils life is a wrong to the imperiled victim; it is a wrong also to his

rescuer. The state that leaves an opening in a bridge is liable to the child that falls into the stream, but liable also to the parent who plunges to its aid. The railroad company whose train approaches without signal is a wrongdoer toward the traveler surprised between the rails, but a wrongdoer also to the bystander who drags him from the path.... The risk of rescue, if only it be not wanton, is born of the occasion. The emergency begets the man. The wrongdoer may not have foreseen the coming of a deliverer. He is accountable as if he had.

Wagner v. Int'l Ry., 232 N.Y. 176, 133 N.E. 437, 437–38 (1921) (citations omitted). That is, those who negligently imperil life or property may not only be liable to their victims, but also to the rescuers. ... ***842** We have consistently and liberally applied the rescue doctrine in this state for over one hundred years. [***] Historically the doctrine arose in questions of proximate cause and contributory negligence. [c] “In other words, did the act of the injured [rescuer] so intervene as to break the chain of causation from [the] defendant’s negligence, or constitute such contributory negligence as to bar recovery?” [c] The general rule was a rescuer would not be deemed to have broken the chain of causation or charged with contributory negligence for reasonable attempts to save the life or property of another. [c] Since the advent of comparative negligence, the doctrine has only arisen on appeal in questions of proximate cause, i.e., when, as here, the defendant claims the rescuer’s actions were a superseding cause of the rescuer’s injuries. *See, e.g., Hollingsworth*, 553 N.W.2d at 598 (holding rescuer’s actions not a superseding cause).¹²³

Proximate Cause

The Gallery contends its alleged negligence was not the proximate cause of Clinkscales’s injuries. The Gallery asserts the facts show its employees ordered patrons to leave the premises, it had called the fire department, and at the time of the rescue attempt Moser was retrieving a rag to turn off the propane valves. The court of appeals held as a matter of law that the rescue doctrine did not apply in this case because “no one was in any danger until the plaintiff placed himself there.”

***843** It is well settled that questions of proximate cause are, absent extraordinary circumstances, for the jury to decide. Iowa R.App. P. 6.14(6)(j); [c]. The line between what is sufficiently proximate and what is too remote is a thin one:

“If upon looking back from the injury, the connection between the negligence and the injury appears unnatural, unreasonable, and improbable in the light of common experience, such negligence would be a remote rather than a proximate cause. If, however, by a fair consideration of the facts based upon common human experience

¹²³ In *Saylor*, we apparently held the rescue doctrine did not apply when the rescuer was injured saving a person who had negligently imperiled himself. Courts and commentators alike have roundly criticized this decision. *See* W.C. Crais III, Annotation, Rescue Doctrine: Negligence and Contributory Negligence in Suit by Rescuer Against Rescued Person, 4 A.L.R.3d 558, 559–60 (1965) (stating all subsequent courts, commentators, and the authors of the Restatement have chosen not to follow *Saylor*, which is “the only authority” barring recovery in so-called first-party rescue cases; noting also that “it does not seem likely that future courts will see fit to revive its teachings”); *see also* *Sears v. Morrison*, 76 Cal.App.4th 577 (1999) (severely criticizing *Saylor*; noting court could find “no case following *Saylor*”); *Britt v. Mangum*, 261 N.C. 250, 252 (1964) (*Saylor* “has not met with favor in other jurisdictions, but instead, when it has been pressed, it has been almost invariably rejected.”); Restatement (Second) of Torts § 445 cmt. d (1965) (rejecting *Saylor* analysis). It appears we overruled *Saylor* sub silentio in *Hollingsworth*. 553 N.W.2d at 598.

and logic, there is nothing particularly unnatural or unreasonable in connecting the injury with the negligence, a jury question would be created.” [c]

Here we are concerned with Clinkscales’s rescue attempt, which The Gallery characterizes as a “superseding cause” of his injuries. A superseding cause is an intervening force that “prevent[s] the defendant from being liable for harm to the plaintiff that the defendant’s antecedent negligence is a substantial factor in bringing about.” *Id.* (citing Restatement (Second) of Torts § 440 (1965) [hereinafter Restatement]).

When a rescue attempt is involved, matters are particularly thorny and a court should be especially wary to grant a defendant’s motion for summary judgment. [c] The rescue doctrine recognizes not all intervening forces are superseding causes:

If the actor’s negligent conduct threatens harm to another’s person, land, or chattels, the normal efforts of the other or a third person to avert the threatened harm are not a superseding cause of harm resulting from such efforts.

Restatement § 445 (quoted in *Hollingsworth*, 553 N.W.2d at 598). That is, so long as the rescuer’s response is “normal,” the negligent actor will not escape liability for the rescuer’s injuries.

What are “normal” rescue efforts? Although in *Hollingsworth* we loosely characterized the question of “normal efforts” as one solely of foreseeability, *see* 553 N.W.2d at 598, in truth the term “normal” is *not* used “in the sense of what is usual, customary, foreseeable, or to be expected.” Restatement § 443 cmt. *b*; *see also id.* § 445 cmt. *b*. Rather, “normal” (referred to in our pre-Restatement cases as “natural”) is used as “the antithesis of abnormal, of extraordinary.” Restatement § 443 cmt. *b*.

[T]he only inquiry should be whether the conduct of the plaintiff was ‘natural’ under the circumstances, which is to be ascertained by a counter-chronological examination of the facts. Here the term ‘natural’ must be taken to embrace those qualities of human nature leading to risk-taking in an effort to preserve property, to rescue other persons, or to save oneself. It necessarily includes actions which these well recognized and familiar human feelings bring about. Thus ‘natural’ conduct includes not only cool and well-reasoned action but also the frantic, excited and apparently illogical movements which are too commonly exhibited by a large percentage of human beings in moments of stress.

In these situations, the defendant may negligently have exposed the person or property of another to unreasonable risk of loss or destruction. ‘Natural’ instincts will move some persons to make efforts at rescue. The movements of the rescuer may not be well judged and may result in harm either to the goods, to the person endangered by the defendant, or to the rescuer himself. In any *844 such case the defendant will be held liable, for the ‘natural’ conduct of the rescuer leaves no break or gap in the chain of causation.

Clayton v. Blair, 254 Iowa 372, 377-378 (1962); *accord* Restatement § 443 cmt. *b*.

What constitutes normal or natural conduct depends upon the circumstances and “is in most cases a question to be decided by the jury.” [cc] If the jury determines the rescuer’s actions are a normal or

natural result of the defendant's actions, the defendant's actions were a proximate cause of the rescuer's injuries.

We think the facts are sufficiently in conflict on the issue of proximate cause to warrant a jury determination. The dangers of fire and gas leaks are well known to all. *See Johannsen*, 232 Iowa at 807 (upholding jury instruction on rescue doctrine when plaintiff rushed onto defendant's property to stop unattended gas leak; as plaintiff shut off valve, leak burst into flames severely injuring plaintiff); *see also Von Tersch v. Ahrendsen*, 251 Iowa 115, 120 (1959) ("The danger of fire is well-known to all."). There is evidence the danger was imminent in this case, or at least apparently so. *See Henneman*, 260 Iowa at 72 (rescue doctrine applies not only when danger is imminent, but also when "the conduct of the rescuer is that of an ordinarily prudent person under existing circumstances"); *accord Silbernagel v. Voss*, 265 F.2d 390, 391–92 (7th Cir.1959) (approving of jury instruction that was "phrased to elicit an answer as to whether the situation ... induce[d] a reasonable belief on part of [the] plaintiff that [the victim] was in imminent peril"); *Wagner*, 133 N.E. at 438 (refuting view that rescue doctrine should not apply when, in fact, rescue attempt was futile); *cf. Fullerton v. Sauer*, 337 F.2d 474, 482 (8th Cir.1964) (construing Iowa law to hold rescue doctrine did not apply when "only apparent or imminent danger" had passed).

This summary-judgment record shows customers, employees, and property of The Gallery were in the vicinity of the fire and subsequent gas leak. While it is undisputed employees of The Gallery called the fire department and asked some patrons to evacuate, a jury could find Clinkscates's rescue efforts were a normal or natural reaction under the circumstances. He may have reasonably thought danger was imminent and, given his extensive training, his help was needed.

Exhortations to leave do not, as a matter of law, preclude liability in all cases. If a defendant sets into course a series of events that induces a rescue attempt, the defendant does not necessarily insulate itself from liability when it tells the rescuer to leave. In any event, in this case there is evidence no one effectively ordered Clinkscates to leave, and some evidence The Gallery enlisted the help of other customers to fight the fire. There is nothing inconsistent with an express general call to evacuate and an implicit individual invitation to help. Even if we were to assume Clinkscates was told to leave, however, this would be but one fact for the jury to consider in evaluating his rescue attempt.

We cannot say as a matter of law that the rescue doctrine does not apply to this case. A reasonable jury could find Clinkscates's rescue of Gallery employees, customers, and property was an act done in normal or natural response to the fear or emotional disturbance caused by The Gallery's negligence. Summary judgment on *845 the issue of proximate cause was not proper.

C. An Open and Obvious Danger is No Bar to Recovery

The district court and court of appeals applied the premises-liability law that persisted at common law and found Clinkscates was an invitee of The Gallery at the time the fire started. Under the common-law trichotomy of invitees, licensees, and trespassers, an invitee is a person "who is invited to enter or remain on land for the purpose directly or indirectly connected with business dealing with the possessor of land." [c] Invitees are owed the highest standard of care under the trichotomy: the possessor of land is obligated to use ordinary care to keep the premises reasonably safe for invitees, to ascertain the actual condition of the premises, and to make the area reasonably safe or give warning of the actual condition and risks involved. *Id.*

The parties do not ask us to re-examine the merits of the trichotomy, which is presently one of the most unsettled and contentious areas of Iowa law. *See Sheets v. Ritt, Ritt, & Ritt, Inc.*, 581 N.W.2d 602, 606 (Iowa 1998) (four of nine members of court favored abolishing distinction between invitees and licensees); *see also Anderson v. State*, 692 N.W.2d 360, 367–68 (Iowa 2005) (use of invitee instruction instead of reasonable care instruction affirmed by operation of law); *Alexander v. Med. Assocs. Clinic*, 646 N.W.2d 74, 79–80 (Iowa 2002) (six of seven members of court declined to abolish common-law trespasser rule). No one challenges that Clinkscales was an invitee. Only a corollary of the common-law premises-liability law is implicated here. The defendants argue, and the lower courts held, the defendants owed no duty to Clinkscales as a matter of law because the fire and gas leak constituted a “known and obvious danger.” It is well settled that generally “[t]he possessor of land . . . is not liable when the injuries sustained by a business invitee were caused by a known or obvious danger.”

Clinkscales argues the open and obvious-danger principle does not apply in this case, and we agree. Fire and escaping gas is obviously dangerous. That is not in doubt. This is not your garden-variety premises-liability case, however—it involves an attempted rescue. Absent imminent danger or the appearance thereof, the rescue doctrine is not applicable. *See, e.g., Weller v. Chi. & Northwestern R.R.*, 244 Iowa 149, 152, 55 (1952) (without imminent danger to child rescue doctrine inapplicable); *Klunenberg*, 256 Iowa at 740 (similar case involving cow in cemetery); *cf. Fullerton*, 337 F.2d at 482 (applying Iowa law and concluding rescue instruction not proper for injuries sustained after rescue completed and when no further apparent or imminent danger to life or property).

In a rescue case such as this, it is *axiomatic* that the danger approached is obviously dangerous. *See, e.g., Hollingsworth*, 553 N.W.2d at 598 (rushing into burning station wagon in victim’s garage); *Clayton*, 254 Iowa at 378–79 (remaining in burning apartment building to help others); *cf. Kester v. Bruns*, 326 N.W.2d 279, 283 (Iowa 1982) (holding rescue instruction not warranted because “it was unreasonable as a matter of law for [the plaintiff] to risk his life to prevent the remote possibility of some harm befalling his \$90 pool cue”).

Danger invites the rescue. To rule the presence of a known and obvious dangerous condition would, as a matter of law, negate any duty to invitee—*846 rescuers would completely eviscerate the rescue doctrine where the rescuer happened to be an invitee of the defendant when the condition first occurred. The “open-and-obvious-danger” rule is not absolute. *See* Restatement § 343A cmt. *f* (carving out an exception “where the possessor has reason to expect that the invitee will proceed to encounter the known or obvious danger because to a reasonable man in his position the advantage of doing so would outweigh the apparent risk”) [c].

We have not accepted similar arguments in previous cases. For example, in *Johannsen*, the plaintiff saw a gasoline spill in the defendant’s railroad yard. 232 Iowa at 807. The plaintiff ran onto the defendant’s property to stop the spill and suffered severe burns. He sued the landowner for negligence and pled rescue. The defendant argued it did not owe the plaintiff a duty of care because he was a trespasser. We held the plaintiff’s status as a trespasser was irrelevant because he was in a place where he had a right to be *when the danger occurred*. *Id.* at 812. The pertinent question was not whether the plaintiff trespassed upon the defendant’s land to effectuate the rescue, but rather whether the negligent acts of the defendant caused a danger that proximately caused the plaintiff’s rescue attempt. *Id.*; *see also Clayton*, 254 Iowa at 378 (rescuer “not regarded as a trespasser” for entering land of another to attempt rescue). Likewise, in the case at bar, it does not matter that Clinkscales was an invitee and

that the grease fire and gas leak constituted an “open and obvious danger.” See *Johannsen*, 232 Iowa at 811 (remarking that the mere fact the plaintiff voluntarily encountered a known danger is not always a bar to recovery). The issue is whether the defendant’s alleged negligent acts proximately caused Clinkscales’s rescue attempt. If trespassers are not precluded as a matter of law from seeking recovery in rescue cases, nor should invitees simply because the danger encountered is a “known and obvious danger.”

D. Negligence

In the alternative, The Gallery argues that even if it owed Clinkscales a duty of care, it did not breach that duty. The district court ruled the defendants were not negligent, as a matter of law, because they asked patrons to leave, called the fire department, and used fire extinguishers. The defendants also point out they have operated the grill for fifteen years without incident and took “precautions to ensure the utmost safety.”

We cannot say as a matter of law that The Gallery was not negligent as alleged in Clinkscales’s petition. Questions of negligence are ordinarily reserved for the jury, and only in extraordinary cases is summary judgment proper. Iowa R.App. P. 6.14(6)(j) [cc] There is testimony the defendants did not clean the grill regularly or sufficiently train their employees in grill cleaning. For example, one of the hoses leading from the propane tanks to the grill had a small “burn hole” in it. There is also evidence Moser permitted the grease fire to persist too long, at times unattended, until it became too large to contain. A jury could also find the defendants did not keep the appropriate type of fire-suppression equipment near the grill. A jury should decide whether The Gallery was negligent, and whether this negligence caused the grease fire, subsequent gas leak, and injuries to Clinkscales.

*847 E. Res Ipsa Loquitur

Res ipsa loquitur (Latin for “the thing speaks for itself”) is a type of circumstantial evidence. *Brewster v. United States*, 542 N.W.2d 524, 529 (Iowa 1996). In Iowa, res ipsa loquitur applies in negligence cases when

(1) the injury is caused by an instrumentality under the exclusive control of the defendant, and (2) the occurrence is such that in the ordinary course of things would not happen if reasonable care had been used. [cc]

Res ipsa loquitur permits a jury to circumstantially “infer the cause of the injury from the naked fact of injury, and then to superadd the further inference that this inferred cause proceeded from negligence.” [c] A jury is not required to draw the inference. [c] Nor must a plaintiff “eliminate with certainty all other possible causes or inferences.” “The jury simply weighs the circumstantial evidence but in the end may or may not accept it as sufficient as to negligence or causation.” In Iowa, we permit the plaintiff to plead res ipsa loquitur in addition to specific negligence as an alternate theory of the case. Clinkscales did precisely this in his petition. Ordinarily the two theories are submitted to the jury together. If the jury finds for the plaintiff on a specific negligence basis, however, it should not entertain res ipsa loquitur. [cc]

For good reasons, the defendants do not deny the grill was in their exclusive control. Instead, they claim res ipsa loquitur does not apply in this case because a grease fire could happen in the absence of

any negligence. Both the district court and court of appeals held the res-ipsa loquitur doctrine was not applicable to this case because grease fires can happen in the absence of a negligent act.

We disagree. The foregoing analysis improperly frames the question. The issue in this case is not simply whether a grease fire could happen in the exercise of ordinary care, because the “occurrence” in this case was not just a grease fire. After all, when Clinkscales approached the grill, the fire was extinguished. The problem was that gas was leaking from the propane tanks, and it appeared reignition of the fire might prove disastrous. Moser testified he heard an abnormal “pop and hiss” come from the grill before the grease fire spread to the tanks. We have repeatedly held the res-ipsa-loquitur doctrine may be applicable in gas leak cases. ...see also Jay M. Zitter, Annotation, *Res Ipsa Loquitur in Gas Leak Cases*, 34 A.L.R.5th 1, 14 (1995) (recognizing “it is clear that in the ordinary course of things gas explosions will not occur, so that when one does occur, an inference of negligence may be reasonable and justifiable”). There is nothing exceptional about this case which indicates that this particular gas leak would ordinarily occur in the absence of negligence. Genuine issues of material fact exist, and therefore the district court erroneously excluded application of res ipsa loquitur from the case. Indeed, to rule otherwise would require Clinkscales to prove the precise cause of his injuries— *848 thus depriving him of the doctrine’s benefit. [c]

Even if we were to ignore the leaking gas, it should be noted that courts have often applied the doctrine of res ipsa loquitur in actions against the occupant of a premises for personal injury caused by fire—including grease fires. See, e.g., *Aetna Cas. & Sur. Co. v. Brown*, 256 So.2d 716, 718 (La.Ct.App.1971) (holding res ipsa loquitur applicable to grease fire); see also 35A Am.Jur.2d *Fires* § 59 (2001). In the ordinary course of things, grease fires do not occur in the absence of negligence and cannot occur unless the party in exclusive control does something or fails to do something an ordinary person would do under the circumstances. Grease fires do not just happen.

V. Conclusion

Summary judgment was not proper. This case is remanded for a trial on the merits. Decision of Court of Appeals Vacated; District Court Judgment Reversed; Remanded.

STREIT, Justice (specially concurring in part and dissenting in part).

I concur to the extent that I believe this rescuer deserves his day in court. The mere fact Clinkscales approached an open and obvious danger is not an absolute bar to recovery; rescue clearly presupposes danger or the appearance thereof. Cf. *Johannsen*, 232 Iowa at 811–12. I respectfully dissent, however, because I believe the majority wrongly permits Clinkscales to pursue a res-ipsa-loquitur theory. In doing so, the majority stretches that venerable doctrine far beyond its proper boundaries.

As the majority correctly points out, in Iowa res ipsa loquitur applies if (1) the injury is caused by an instrumentality under the exclusive control of the defendant, and (2) the occurrence is such that in the ordinary course of things would not happen if reasonable care had been used. *Novak*, 622 N.W.2d at 498.

Because Clinkscales has not presented any evidence of either element, I would affirm the district court and court of appeals on this issue.

No Exclusive Control

It is conceded The Gallery had exclusive control of the grill *at the time of the accident*. On the facts of this case, however, this is insufficient in itself to warrant a *res ipsa loquitur* instruction. Exclusive control must be shown *at the time of the alleged negligence*, which is not necessarily the time of injury. [cc] As we recently stated,

The plaintiff need only show that the defendant controlled the instrumentality at the time of the alleged negligent act.... The “exclusive control” requirement is simply another way of saying that the injury must be traced to a specific instrumentality or cause for which the defendant was responsible *849 ... Where causes for the injury other than a defendant’s negligence are equally probable, there must be evidence which will permit the jury to eliminate them. This means, for example, that a plaintiff injured by the explosion of a beer bottle purchased from a retailer will be required to make some sufficient showing that the bottle was not cracked by mishandling after it left the defendant’s plant. *Weyerhaeuser Co. v. Thermogas Co.*, 620 N.W.2d 819, 832 (Iowa 2000) (citations, internal quotations, and emphasis omitted).

The record before us shows, in undisputed fashion, that several parties other than the defendants played a role that gave rise to the state of the grill as it malfunctioned on the date of Clinkscales’s injuries. The defendants special ordered the grill from two local men, who built it from standard parts. After the defendants purchased the grill, they regularly had the propane tanks switched out at a local filling station. This filling station also periodically replaced the devices that connected the tanks to the hoses that led to the grill, because the connections on the tanks themselves would change from time to time. Any of these parties, as well as any of the manufacturers of any of the parts they built, used, or serviced, could have performed a negligent act leading to Clinkscales’s injuries. The same could be said for the patron extinguishing the fire. Without proving the cause of the fire, Clinkscales has presented no evidence that would permit a jury to eliminate any of these equally potentially negligent parties. Therefore *res ipsa loquitur* is inapplicable, and the district court and court of appeals were correct to strike this theory from Clinkscales’s pleadings.¹²⁴

Grease Fires Happen

Nor has Clinkscales shown the grease fire was such that in the ordinary course of things it would not have happened if reasonable care had been used. As the district court and court of appeals both pointed out, grease fires commonly occur in the absence of negligence.

The classic English case of *Byrne v. Boadle*, 159 Eng. Rep. 299 (Ex. 1863), perhaps best illustrates the sorts of cases in which *res ipsa loquitur* properly applies, and how it works. In *Byrne*, a barrel of flour

¹²⁴ As a related matter, it should be remembered that *res ipsa loquitur* is not applicable simply because Clinkscales may not be able to show which specific acts of negligence caused his injuries. As one noted commentator has pointed out, *res ipsa loquitur* is sometimes invoked needlessly and inappropriately. If the trier can infer that the defendant was probably guilty of one of several specific acts of negligence but cannot be sure which act it was, *res ipsa loquitur* is not properly involved.... Although the jury might not be sure which of these negligent [acts] occurred, if it can conclude that one of them did, then the case is merely one of ordinary circumstantial evidence.... When courts speak of *res ipsa loquitur* in cases like this perhaps no harm is done, but they risk confusing the process of inferring specific negligent acts with the process of estimating the probability of unknown acts of negligence. 1 Dan B. Dobbs, *The Law of Torts* § 154, at 372–73 (2001) (footnote omitted). While Clinkscales has presented a number of independent theories as to how the defendants were negligent and should be permitted to make his case to the jury on each, *res ipsa loquitur* is not available simply because there is uncertainty at this stage in the proceedings about which particular theory may win the day. The majority’s decision falls into precisely this trap.

fell on the plaintiff, who was walking next to the defendant's shop. 159 Eng. Rep. at 299. Although one could readily infer the barrel came from the defendant's shop, the plaintiff could not show precisely how the defendant was negligent. *Id.* Nonetheless, the court thought the accident "spoke for itself" and therefore held *850 the defendant was negligent, albeit in some unspecified way. *Id.* at 301.

The case at bar is manifestly unlike *Byrne*. Grease fires—unlike barrels of flour falling from the sky—occur in the absence of negligence. Put simply, *res ipsa loquitur* should not apply here because this is not the sort of case for which the doctrine was designed. In holding to the contrary, the majority stretches *res ipsa loquitur* beyond its proper scope.

Note 1. What do you notice about the court's narration of the facts? What do we know about the various parties and their attributes?

Note 2. How do the majority and dissenting opinions differ with respect to their views of RIL?

Note 3. What differentiates an intervening force from a superseding cause? Does this distinction seem to you to *lead to* an analytic conclusion or to *require* one? The Restatement (Second) of Torts § 440 defines a superseding cause as "an act of a third person or other force which by its intervention prevents the actor from being liable for harm to another which his antecedent negligence is a substantial factor in bringing about."

The next case explores superseding cause analysis in more depth.

Chacko v. Com., Dept. of Transp., Commonwealth Court of Pennsylvania (1992) (148 Pa. Cmwlth. 494)

*496 This personal injury action arises from an automobile accident which occurred in the City of Philadelphia on September 20, 1985. Saramma Chacko and Celinamma John were passengers in an automobile operated by defendant Ruby Matthews (Matthews). Matthews, who suffers from diabetes, lost consciousness and then control of the vehicle. The vehicle left the roadway and struck a utility pole owned by defendant Philadelphia Electric Company (PECO). Liability was asserted against the City on [various theories on which the trial court granted the City's motion for summary judgment]. [***] "...A trier of fact could not reasonably conclude that any action of the City was a contributing factor to Plaintiffs' injuries, given that the driver had no control over his [sic] vehicle at all." Trial Court Opinion at 2–3. [***]

Assuming *arguendo* that the acts and omissions alleged against the City were legal causes of Appellants' injuries, the proper inquiry is whether the subsequent loss of consciousness suffered by Matthews was an intervening cause, which would not absolve the City of liability, or a superseding cause, which would. See *Vattimo v. Lower Bucks Hospital, Inc.*, 502 Pa. 241 (1983). The Restatement (Second) of Torts (Restatement 2d) defines a superseding cause as "an act of a third person or other force which by its intervention prevents the actor from being liable for harm to another which his antecedent negligence is a substantial factor in bringing about." Restatement 2d § 440. Among the factors to consider in determining whether a subsequent force is an intervening or superseding cause

are whether the force is operating independently of any situation created by the first actor's negligence and whether it is or is not a normal result of that situation. Restatement 2d § 442(c).

In *Vattimo*, the Supreme Court quoted with approval this court's analysis of superseding causes:

[E]ven where an intervening act is wrongful it does not become a superseding cause unless, looking retrospectively from the harm through the sequence of events by which it was produced, it is so extraordinary as not to have been reasonably foreseeable. *500 502 Pa. at 253 (quoting 59 Pa. Commonwealth Ct. 1, 9–10 (1981)). Matthews's loss of consciousness was indeed extraordinary and not reasonably foreseeable. It operated independently of, and cannot be said to be a normal result of, any situation created by the City's purported acts and omissions.

Accordingly, we hold that the trial court did not err or abuse its discretion in concluding that the driver's loss of consciousness was a superseding cause of Appellants' injuries and in granting summary judgment on that basis.¹²⁵

For the foregoing reasons, the order of the trial court is affirmed.

Note 1. Why does the court assume, "arguendo" that the city's alleged acts of negligence were the legal causes of appellants' injuries and what do they mean in describing the alleged acts in that way?

Note 2. Do the Restatement's factors for determining whether a force is intervening or a superseding cause test seem straightforward to apply? Restatement (Second) of Torts § 440: "Among the factors to consider in determining whether a subsequent force is an intervening or superseding cause are whether the force is operating independently of any situation created by the first actor's negligence and whether it is or is not a normal result of that situation. Restatement (Second) of Torts § 442(c).

Note 3. As with proximate cause more generally, analysis to determine superseding causation exists primarily to limit liability. Thus third parties who act and create harms *due to* the original tortfeasor's conduct do not usually sever the chain of causation: "If the actor's negligent conduct threatens harm to another's person, land, or chattels, the normal efforts of the other or a third person to avert the threatened harm are not a superseding cause of harm resulting from such efforts." Restatement (Second) of Torts § 445. How far should this rule extend? What are "normal efforts"? Recall the discussion in *Clinkscales* distinguishing normal from extraordinary circumstances.

¹²⁵ In general, the issue of whether a given force is a superseding or intervening cause is a question to be resolved by the fact finder. However, in cases where a jury may not reasonably differ, it is proper for the court to make a determination of causation. *Vattimo*, 502 Pa. at 247, 465 A.2d at 1234; Restatement 2d § 434.

Check Your Understanding (3-9)

Question 1. The purposes of the rescue doctrine are to:

An interactive H5P element has been excluded from this version of the text. You can view it online here: <https://saidtorts2d.lawbooks.cali.org/?p=67#h5p-93>

Question 2. In which of the following scenarios is the rescuer **least** likely to be able to apply the rescue doctrine:

An interactive H5P element has been excluded from this version of the text. You can view it online here: <https://saidtorts2d.lawbooks.cali.org/?p=67#h5p-94>

Question 3. True or false: In a circumstance in which antecedent (prior) negligence has taken place, a later superseding cause effectively immunizes, or at least limits, the antecedent defendant from liability for the harmful consequences of the superseding cause.

An interactive H5P element has been excluded from this version of the text. You can view it online here: <https://saidtorts2d.lawbooks.cali.org/?p=67#h5p-95>

Negligence: Harm

As you have seen, plaintiffs must prove all four elements of negligence—duty, breach, causation and harm—and some kinds of harm are not cognizable, such as purely economic losses and emotional distress absent particular qualifying circumstances. However, physical injuries and property losses as well as the related expenses to treat or repair the damage wrought by a negligent tortfeasor’s conduct will generally satisfy this element. A separate module on damages works through the relevant doctrines in greater detail.

A key distinction between tort’s regimes is that plaintiffs need to prove harm with respect to negligence and strict liability claims but they need not prove harm for several of the intentional torts, namely battery, assault, false imprisonment, conversion and trespass to land. A plaintiff’s damages award will be correspondingly lower when they cannot prove that those intentional torts have left lasting harm but the liability claim does not *depend* on proof of harm the way it does for negligence and strict liability claims. The invasion of the interest *is* the harm. Recall that for trespass to chattels, a plaintiff *does* have to prove harm as part of the prima facie case for liability. For IIED, a plaintiff must not only prove harm but a heightened level of harm: *severe* emotional distress.

MODULE 4. DEFENSES, PRIVILEGES, IMMUNITIES AND LIMITATIONS

This Module focuses on various defenses, privileges, immunities, and limitations on liability. It begins with defenses rooted in the plaintiff's behavior before turning to defenses rooted in the defendant's status (such as immunity), as well as other privileges and limitations (such as self-defense, defense of others, and statutes of limitation).

Chapter 22. Plaintiff's Conduct

1. Assumption of the Risk

Focusing on the plaintiff's conduct first, there are three main categories: **assumption of the risk**, **contributory negligence**, and **comparative negligence**. Focusing on assumption of the risk, you will see that it falls into two (or more) categories: **express** and **implied assumption of the risk**. Express assumption of the risk involves waivers of liability or clear assent to the risks while implied assumption of the risk is often described in terms of the duty (or limits on the duty) of the defendant, based on the plaintiff's willing participation in something risky. There are two types of implied assumption of the risk (primary assumption of the risk and secondary assumption of the risk), and some courts have drilled even further into those. As you will see, these gradations pertaining to plaintiffs' behavior will pull us ever deeper into the world of tort law's defenses and, in particular, the complex terrain of comparative fault.

Keep in mind that the theory behind assumption of the risk is *somewhat* like the theory of consent, wherever you see it substantively in other doctrines. If you decide you want to be adventurous, according to tort law, the law should allow you to do so. But then, it also will hold that your ability to sue for injuries incurred during the adventure will be limited in significant ways. The law has developed these limitations on liability and related doctrines over time, and while there are many contexts for this discussion, we will begin with one singled out by Justice Cardozo.

With apologies for the way in which tort law just continues to rain on every parade, our next case directs our attention to the serious risks associated with injuries at amusement parks, in the context of defenses to negligence. As a treatise on tort law writes, there are many:

injuries suffered by riders on amusement park attractions, including the traditional mechanical rides common at carnivals and amusement parks, and the various water slides and raft rides that now proliferate at theme parks. A patron on such a ride may be injured in a great number of ways. Cases ... involve patrons injured in the apparently normal course of a ride, in which case the design of the ride becomes the primary issue. In addition, cases often include some combination of allegations that rides were negligently maintained or operated, or that patrons were not adequately protected from negligent spectators. 16 Causes of Action 2d 1 (Originally published in 2001)

There are spinal injuries, many broken bones and injuries, severed thumbs (why must there be so many severed thumbs?) as well as the occasional death by drowning, electrocution, alligator attack or other catastrophic injury. The injuries are tragic, yet thankfully, very infrequent, unless you're at Action Park, apparently. Action Park was a notorious amusement park and tort magnet that people who came of age in the 1980s on the East Coast remember fondly.

Here are some sources to explore on the topic:

"Defunctland: The History of Action Park" (17-minute video):

<https://www.youtube.com/watch?v=flkW-ceNvck>

Trailer for the documentary “Class Action Park” (2020) (2-minute video):

<https://www.classactionpark.com/>

Interview with Director of “Class Action Park” (5-minute video):

<https://www.youtube.com/watch?v=g1i4zA5RjaE>

For further reading about Action Park if you’re curious:

<https://www.njherald.com/article/20140609/NEWS/909029323>

<https://weirdnj.com/stories/action-park/>

These sources document how dangerous Action Park was. While it was unusually dangerous—deadly, even—it was not unique in regularly exposing visitors to considerable risks of injury in an industry that was not thoroughly regulated. Today, other amusement parks remain open, subject to various regulations, statutes, and of course, tort liability. If you have ever been into an amusement park, you know why they are still open. Either you had a great time (for at least a part of your time there) or you observed how much fun others were having. Indeed, people pay a lot of money and brave long lines, sunburns, loud noises, absurdly expensive sub-par food, and yes, very real risks of injury. Visitors are clearly flocking to parks (at least in non-pandemic times) of their own volition. (Full disclosure: “visitors... flocking” includes this author; we have an annual family trip that has often featured a trip to the local amusement park).

But at what point, if any, do these parks and their activities become too risky to allow? To what extent, normatively, *should* the law impinge on the autonomy of thrill-seekers who may be perfectly aware of the risks and simply wish to assume them, thank you very much? In the case of those who went to Action Park, as you saw in the videos linked above, *the very point of the fun was the genuine danger*. Tort law’s purposes, if we include the ideas of autonomy, consent and choice, are very much in tension in the context of allowing but still regulating adventurous activities that can tend to produce frequent or severe injuries, or both. Often, the difficult questions will be the scope of the risk assumed and the gradations of negligence in the conduct of those running the dangerous or risky activity.

Murphy v. Steeplechase Amusement Co., Court of Appeals of New York (1929) (250 N.Y. 479) (Justice Cardozo)

The defendant, Steeplechase Amusement Company, maintains an amusement park at Coney Island, New York. One of the supposed attractions is known as “The Flopper.” It is a moving belt, running upward on an inclined plane, on which passengers sit or stand. Many of them are unable to keep their feet because of the movement of the belt, and are thrown backward or aside. The belt runs in a groove, with padded walls on either side to a height of four feet, and with padded flooring *481 beyond the walls at the same angle as the belt. An electric motor, driven by current furnished by the Brooklyn Edison Company, supplies the needed power.

Plaintiff, a vigorous young man, visited the park with friends. One of them, a young woman, now his wife, stepped upon the moving belt. Plaintiff followed and stepped behind her. As he did so, he felt what he describes as a sudden jerk, and was thrown to the floor. His wife in front and also friends

behind him were thrown at the same time. Something more was here, as every one understood, than the slowly-moving escalator that is common in shops and public places. A fall was foreseen as one of the risks of the adventure. There would have been no point to the whole thing, no adventure about it, if the risk had not been there. The very name above the gate, the Flopper, was warning to the timid. If the name was not enough, there was warning more distinct in the experience of others. We are told by the plaintiff's wife that the members of her party stood looking at the sport before joining in it themselves. Some aboard the belt were able, as she viewed them, to sit down with decorum or even to stand and keep their footing; others jumped or fell. The tumbling bodies and the screams and laughter supplied the merriment and fun. "I took a chance," she said when asked whether she thought that a fall might be expected.

Plaintiff took the chance with her, but, less lucky than his companions, suffered a fracture of a knee cap. He states in his complaint that the belt was dangerous to life and limb in that it stopped and started violently and suddenly and was not properly equipped to prevent injuries to persons who were using it without knowledge of its dangers, and in a bill of particulars he adds that it was operated at a fast and dangerous rate of speed and was not supplied with a proper railing, guard or other device to prevent a fall therefrom. No other negligence is charged.

***482** We see no adequate basis for a finding that the belt was out of order. It was already in motion when the plaintiff put his foot on it. He cannot help himself to a verdict in such circumstances by the addition of the facile comment that it threw him with a jerk. One who steps upon a moving belt and finds his heels above his head is in no position to discriminate with nicety between the successive stages of the shock, between the jerk which is a cause and the jerk, accompanying the fall, as an instantaneous effect. There is evidence for the defendant that power was transmitted smoothly, and could not be transmitted otherwise. If the movement was spasmodic, it was an unexplained and, it seems, an inexplicable departure from the normal workings of the mechanism. An aberration so extraordinary, if it is to lay the basis for a verdict, should rest on something firmer than a mere descriptive epithet, a summary of the sensations of a tense and crowded moment ... But the jerk, if it were established, would add little to the case. Whether the movement of the belt was uniform or irregular, the risk at greatest was a fall. This was the very hazard that was invited and foreseen...

Volenti non fit injuria. One who takes part in such a sport accepts the dangers that inhere in it so far as they are obvious and necessary, just as a fencer accepts the risk of a thrust by his antagonist or a spectator at a ball game the chance of contact with the ball ***483** ... The antics of the clown are not the paces of the cloistered cleric. The rough and boisterous joke, the horseplay of the crowd, evokes its own guffaws, but they are not the pleasures of tranquility. The plaintiff was not seeking a retreat for meditation. Visitors were tumbling about the belt to the merriment of onlookers when he made his choice to join them. He took the chance of a like fate, with whatever damage to his body might ensue from such a fall. The timorous may stay at home.

A different case would be here if the dangers inherent in the sport were obscure or unobserved (*Godfrey v. Conn. Co.*, supra; *Tantillo v. Goldstein Bros. Amusement Co.*, 248 N. Y. 286), or so serious as to justify the belief that precautions of some kind must have been taken to avert them (cf. *O'Callaghan v. Dellwood Park Co.*, 242 Ill. 336). Nothing happened to the plaintiff except what common experience tells us may happen at any time as the consequence of a sudden fall. Many a skater or a horseman can rehearse a tale of equal woe. A different case there would also be if the accidents had been so many as to show that the game in its inherent nature was too dangerous to be continued without change. The

president of the amusement company says that there had never been such an accident before. A nurse employed at an emergency hospital maintained in connection with the park contradicts him to some extent. She says that on other occasions she had attended patrons of the park who had been injured at the Flopper, how many she could not say. None, however, had been badly injured or had suffered broken bones. Such testimony is not enough to show that the game was a trap for the unwary, too perilous to be endured. According to the defendant's estimate, two hundred and fifty thousand visitors were at the Flopper in a year. Some quota of accidents was to be looked for in so great a mass. One might as well say that a skating rink should be abandoned because skaters sometimes fall.

***484** There is testimony by the plaintiff that he fell upon wood, and not upon a canvas padding. He is strongly contradicted by the photographs and by the witnesses for the defendant, and is without corroboration in the testimony of his companions who were witnesses in his behalf. If his observation was correct, there was a defect in the equipment, and one not obvious or known. The padding should have been kept in repair to break the force of any fall. The case did not go to the jury, however, upon any such theory of the defendant's liability, nor is the defect fairly suggested by the plaintiff's bill of particulars, which limits his complaint. The case went to the jury upon the theory that negligence was dependent upon a sharp and sudden jerk.

The judgment of the Appellate Division and that of the Trial Term should be reversed, and a new trial granted, with costs to abide the event.

Note 1. "The timorous may stay at home" has to be one of the top 20 phrases ever published in an opinion on tort law. Its durability may be due in part to its use of the unusual word "timorous" (fearful) which Cardozo uses, somewhat obnoxiously, to classify people who don't seek thrills on roller-coasters. But it is also likely memorable for the tough love Cardozo seems to be showing towards those who willingly seek thrills. His point is the willing cannot recover for injuries caused by the things they willingly did ("volenti non fit injuria"). In one sense, this merely mirrors the ideas of bodily autonomy that undergird the tort of battery, as you saw earlier in the term. It is a form of aligning liability with the concept of consent. In another sense, however, it is creating a contract-like principle: if you *agree* to subject yourself to certain risks, you must be held to that earlier agreement.

Note 2. If the rationale is that the rider of "The Flopper" assumed the risk of falling, is an unforeseen and unexplained jerk caused by the machine the same kind of risk young Mr. Murphy assumed? In your mind, is this more properly a question of duty or proximate cause? A question of law or of fact, in other words?

Note 3. How far should assumption of the risk be allowed to go, from a policy perspective? On Friday, October 30, 2020, a news story reported that a man who had specially paid to spend time with a leopard was mauled and severely injured:

<https://fox8.com/news/man-mauled-after-paying-for-full-contact-leopard-experience-in-florida/>

If we assume that strict liability is applicable to any conduct involving wild animals, does it make sense to allow entities to "contract around" the harm they might suffer? More generally, should waivers of liability be allowed to limit possible tort liability, thus turning this domain into one governed by contract, rather than tort law? Why or why not? What are the costs and benefits of allowing waivers of liability? What alternatives exist?

Release of Liability and Express Assumption of the Risk

The next two cases present different resolutions of disputes over waivers of liability for Scuba diving lessons. As you read them, consider what distinguishes them as well as the common threads that run through them.

Boyce v. West, Court of Appeals of Washington, Division 3 (1993) (71 Wash. App. 657)

This is a wrongful death action arising out of a scuba diving accident. The court dismissed the defendants on summary judgment after finding the decedent Peter Boyce had released them from liability and assumed all risks associated with the scuba diving course he was taking. Iris Boyce appeals, contending the liability releases that her son signed did not cover instructor James West and should not be enforced as to Gonzaga University as a matter of public policy. Mrs. Boyce further contends there are genuine issues of material fact as to whether Mr. West was grossly negligent and whether her son assumed the risk of negligent instruction and supervision by Mr. West. We affirm.

Mr. Boyce was a student at Gonzaga University. In the spring of 1988, during his freshman year, he enrolled in Scuba Diving 1, an introductory scuba diving course offered as a physical education elective. At the beginning of the course he signed documents entitled PADI¹²⁶ Standard Safe Diving Practices Statement of Understanding”, “PADI Medical Statement”, and “Affirmation and Liability Release”. The latter document purported to release Down Under Divers and PADI from all liability for negligence and to affirm Mr. *660 Boyce’s full assumption of all risks associated with the program. Mr. Boyce successfully completed the course, taught by Down Under Divers’ employee John Miller; he earned an A and received one credit. All dives took place in the school’s swimming pool.

During the summer, Mr. Boyce became a certified scuba diver after completing at least four open-water dives with an independent certifying authority. Certification was a prerequisite for taking the advanced scuba diving course (Scuba Diving 2) offered by Gonzaga. In the fall of 1988, Mr. Boyce enrolled in Scuba Diving 2, which was taught by James West, an adjunct instructor at Gonzaga and owner of Down Under Divers. At the first class on September 5, Mr. Boyce again signed documents entitled “PADI Standard Safe Diving Practices Statement of Understanding”, “PADI Medical Statement”, and “Affirmation and Liability Release”. The forms were not identical to those he had signed for the beginning course, but were substantially similar. This time the release named PADI and Gonzaga University.

By November 27, 1988 Mr. Boyce had successfully completed three of the five specialty dives planned for the course. He died that day during the fourth dive, a deepwater dive in Lake Coeur d’Alene. The diving group consisted of instructor West, Mr. Boyce, and two other students, Steve Kozlowski and John Sterling. The dive required the use of dry suits, so they had spent several hours the day before learning to use them. During the dive the divers descended 80 to 100 feet along an anchor line to the bottom of the lake, then swam 10 to 15 feet to a wreck. There, Mr. West checked his students’ air supplies. Concerned that they were running low on air because Mr. Kozlowski and Mr. Boyce both

¹²⁶ PADI stands for Professional Association of Diving Instructors.

registered only 800 pounds of air, one-half of the amount they started with, he signaled the group to return to the anchor line and ascend to the surface. When they got back to the anchor line, Mr. Kozlowski indicated he was very low on air: he had just 100 *661 pounds of air left. As Mr. West turned to check on Mr. Sterling and Mr. Boyce, Mr. Kozlowski tugged at him, panicked over lack of air. Mr. West immediately gave Mr. Kozlowski his alternate regulator and assisted him to the surface, buddy breathing along the way. In the emergency, he lost sight of Mr. Boyce. Mr. West next saw Mr. Boyce floating on the surface. Resuscitation efforts were unsuccessful; Mr. Boyce died of air embolism resulting from too rapid an ascent.

Iris Boyce, as personal representative of her son's estate, sued Mr. West and Gonzaga for wrongful death. The complaint asserts Mr. West negligently caused Mr. Boyce's death and Gonzaga is vicariously liable for the negligence of its agent. The defendants denied negligence and asserted as alternative affirmative defenses the release of liability¹²⁷ and assumption of risk¹²⁸ provisions contained in the documents signed by Mr. Boyce.

Mr. West and Gonzaga moved for summary judgment. Mrs. Boyce resisted the motion and submitted parts of a deposition of Charles R. Lewis, a dive master, in which Mr. Lewis expresses his opinion that Mr. West was negligent in his instruction and supervision of the students. Mr. Lewis did acknowledge that with the 50 pounds of air Mr. Boyce still had when he reached the surface, he would have had enough air had he continued to exhale on the way up, and that free ascents have been made from greater depths. By memorandum decision entered April 15, 1992, the court granted the motion for summary judgment.

RELEASE OF LIABILITY

Mrs. Boyce first contends neither of the releases of liability signed by Mr. Boyce cover Mr. West. We agree the spring release does not apply to Mr. West,¹²⁹ and conclude the fall release does.

A release is a contract in which one party agrees to abandon or relinquish a claim, obligation or cause of action against another party. [c] As a contract, a release is to be construed according to the legal principles applicable to contracts. [c] Exculpatory clauses are strictly construed and must be clear if the release from liability is to be enforced. [c]

The fall release, signed September 5, 1988, names only Gonzaga and PADI. Mrs. Boyce concedes it releases Gonzaga from liability unless a public interest is involved. The release does not name Mr.

¹²⁷ "I understand and agree that neither ... Gonzaga University ... nor [PADI] may be held liable in any way for any occurrence in connection with this diving class that may result in injury, death, or other damages to me or my family, heirs, or assigns, ... and further to save and hold harmless said program and persons from any claim by me, or my family, estate, heirs, or assigns, arising out of my enrollment and participation in this course." "It is the intention of [Peter Boyce] by this instrument to exempt and release [Gonzaga University] and [PADI] from all liability whatsoever for personal injury, property damage or wrongful death caused by negligence."

¹²⁸ "[I]n consideration of being allowed to enroll in this course, I hereby personally assume all risks in connection with said course, for any harm, injury or damage that may befall me while I am enrolled as a student of the course, including all risks connected therewith, whether foreseen or unforeseen; ..."

¹²⁹ The spring release, signed on January 20, 1988, names only Down Under Divers and PADI; it does not mention or in any way refer to Mr. West or Gonzaga. It was executed by Mr. Boyce for the introductory scuba diving course he took in the spring. That course was successfully completed without incident and none of the allegations in the wrongful death complaint pertain to it. The spring release has no relevance to this lawsuit. The trial court erred by finding it protected Mr. West from liability.

West, but it is undisputed that Mr. West was Gonzaga's employee. The general rule is that a pre-injury release of the employer from liability also releases the employee.¹³⁰

Restatement (Second) of Agency § 347(2) & comment *663 b (1958); [c]. [***] Mr. West, as an employee of Gonzaga, was covered by the agreement releasing Gonzaga from liability for negligent harm to Mr. Boyce.

Mrs. Boyce next contends the release of Gonzaga from liability violates public policy and should not be enforced. In Washington, contracts of release of liability for negligence are valid unless a public interest is involved. *Hewitt v. Miller*, 11 Wash.App. 72, 521 P.2d 244, review denied, 84 Wash.2d 1007 (1974).

Wagenblast v. Odessa Sch. Dist. 105-157-166J, 110 Wash.2d 845, 758 P.2d 968, 85 A.L.R.4th 331 (1988) sets forth six factors, taken from *Tunkl v. Regents of Univ. of Cal.*, 60 Cal.2d 92, 32 Cal.Rptr. 33, 383 P.2d 441, 6 A.L.R.3d 693 (1963), which are to be considered in determining whether exculpatory agreements violate public policy. The court considers whether

- (1) the agreement concerns an endeavor of a type *664 generally thought suitable for public regulation;
- (2) the party seeking exculpation is engaged in performing a service of great importance to the public, which is often a matter of practical necessity for some members of the public;
- (3) such party holds itself out as willing to perform this service for any member of the public who seeks it, or at least for any member coming within certain established standards;
- (4) because of the essential nature of the service, in the economic setting of the transaction, the party invoking exculpation possesses a decisive advantage of bargaining strength against any member of the public who seeks the services;
- (5) in exercising a superior bargaining power, the party confronts the public with a standardized adhesion contract of exculpation, and makes no provision whereby a purchaser may pay additional reasonable fees and obtain protection against negligence; and
- (6) the person or property of members of the public seeking such services must be placed under the control of the furnisher of the services, subject to the risk of carelessness on the part of the furnisher, its employees or agents. *Wagenblast*, 110 Wash.2d at 851-55, 758 P.2d 968.

Those factors are not present here. As noted in *Hewitt*, 11 Wash.App. at 74, 521 P.2d 244, "[e]xtended discussion is not required to conclude that instruction in scuba diving does not involve a public duty...." *Accord, Blide v. Rainier Mountaineering, Inc.*, 30 Wash.App. 571, 574, 636 P.2d 492 (1981), review denied, 96 Wash.2d 1027 (1982), in which the court noted: "Although a popular sport in Washington, mountaineering, like scuba diving, does not involve public interest...."

Madison v. Superior Court, 203 Cal.App.3d 589, 250 Cal.Rptr. 299 (1988) is a factually similar case arising out of the death of a student enrolled in a scuba diving course offered through the YMCA.

¹³⁰ Mrs. Boyce argues to the contrary, citing *Vanderpool v. Grange Ins. Ass'n*, 110 Wash.2d 483, 756 P.2d 111 (1988). However, *Vanderpool* involved a post-injury settlement and the release of an employer from vicarious liability. The case was decided on the basis of RCW 4.22.060(2), which states:

A release ... entered into by a claimant and a person liable discharges that person from all liability for contribution, but it does not discharge any other persons liable upon the same claim unless it so provides. That statute does not apply in this case.

The *Madison* court applied the *Tunkl* factors and concluded a release signed by the scuba student did not involve a public interest. It then observed, in words that apply to this case as well:

Here, [decedent] certainly had the option of not taking the class. There was no practical necessity that he do so. In view of the *665 dangerous nature of this particular activity defendants could reasonably require the execution of the release as a condition of enrollment. [Decedent] entered into a private and voluntary transaction in which, in exchange for an enrollment in a class which he desired to take, he freely agreed to waive any claim against the defendants for a negligent act by them. This case involves no more a question of public interest than does motorcross racing, sky diving, or motorcycle dirtbike riding. (Citations omitted.) *Madison*, 250 Cal.Rptr. at 305–06.

We do not find a public interest in a private school¹³¹ offering scuba diving instruction to qualified students as an elective course. Upholding the release of Gonzaga does not violate public policy.

Mrs. Boyce further contends there are issues of material fact whether the defendants were grossly negligent. If Mr. West's negligent acts fell greatly below the standard established by law for the protection of others against unreasonable risk of harm, the releases are unenforceable. *Blide*, 30 Wash.App. at 573.

A defendant who can point out to the trial court that the plaintiff lacks competent evidence to support an essential element of the plaintiff's case is entitled to summary judgment because a complete failure of proof concerning an element necessarily renders all other facts immaterial. [...] Evidence of negligence is not evidence of gross negligence; to raise an issue of gross negligence, there must be substantial evidence of serious negligence. *Nist v. Tudor*, 67 Wash.2d 322, 332 (1965). Since a release of liability exculpates ordinary negligence, if it occurs, the plaintiff must establish gross negligence affirmatively to avoid enforcement of the release.

Mrs. Boyce neither alleged gross negligence in her complaint, nor amended it to make that allegation, nor provided *666 the court with any evidence supporting an allegation of gross negligence. The only evidence of any degree of negligence presented by Mrs. Boyce consists of excerpts of the deposition testimony of her expert, Mr. Lewis. In those excerpts, Mr. Lewis expresses his opinion that Mr. West was negligent. However, as the trial court found, nothing in Mr. Lewis' testimony supports Mrs. Boyce's assertion that Mr. West was grossly negligent. Mrs. Boyce's allegation, supported by nothing more substantial than argument, is insufficient to defeat a motion for summary judgment. CR 56(e); *Guile*, 70 Wash.App. at 25. Because there was no material issue of fact as to the existence of gross negligence, an essential element for avoidance of the release of liability, summary judgment was proper.

ASSUMPTION OF RISK

Mrs. Boyce, in response to respondents' alternative defense, also contends her son did not assume the risk of negligent instruction and supervision. She argues assumption of the risk, whether express or primary implied, bars recovery only for injuries resulting from known risks voluntarily assumed. *Kirk v. WSU*, 109 Wash.2d 448, 453–54 (1987) and cases cited therein. Thus, to the extent Mr. Boyce's

¹³¹ As a private school, Gonzaga is not in a substantially different position than the YMCA in *Madison* or the private business in *Hewitt*.

death resulted from other unknown risks, created by the defendants, Mrs. Boyce argues Mr. West and Gonzaga remain liable. *Kirk*, at 455. *See also Scott v. Pacific West Mt. Resort*, 119 Wash.2d 484, 499 (1992).

In its memorandum decision, the trial court blurs the distinction between express assumption of the risk and implied primary assumption of the risk and refers to “express primary assumption of the risk.” The confusion is understandable; the entire doctrine is surrounded by confusion. ... Express assumption of risk arises out of a contract concept; implied primary assumption of risk arises out of a tort concept. ... Identical in result to a release of liability which exculpates for ordinary negligence if it occurs, express and primary implied assumption of risk exculpate by shifting the duty of care from the defendant to the plaintiff, thus preventing negligence from *667 occurring. Express assumption of risk bars a claim resulting from risks *actually assumed* by the plaintiff; implied primary assumption of risk bars a claim resulting from specific *known* and *appreciated* risks. *Scott*, at 497. One who participates in sports impliedly assumes the risks which are inherent in the sport. *Scott*, at 498.

(1) *Express assumption of risk*. Mr. Boyce acknowledged the possibility of death from scuba diving and assumed “all risks in connection with [the scuba diving] course ... while I am enrolled as a student of the course, including all risks connected therewith, whether foreseen or unforeseen ...” Negligent instruction and supervision are clearly risks associated with being a student in a scuba diving course and are encompassed by the broad language of the contract. That Mr. Boyce may not have specifically considered the possibility of instructor negligence when he signed the release does not invalidate his express assumption of *all risks* associated with his participation in the course. Again, the words used by the court in *Madison*, 250 Cal.Rptr. at 306 (quoting from *Coates v. Newhall Land & Farming, Inc.*, 191 Cal.App.3d 1, 9 (1987)), apply just as well to this case:

“... knowledge of a particular risk is unnecessary when there is an express agreement to assume all risk; by express agreement a ‘plaintiff may undertake to assume all of the risks of a particular ... situation, *whether they are known or unknown to him.*’ [cc]

As with the release of liability exculpating ordinary negligence, in the absence of a showing of gross negligence Mr. Boyce’s express assumption of all risks associated with his enrollment in the scuba diving course bars a claim for recovery... The summary judgment on this alternative defense was also proper.

(2) *Implied primary assumption of risk*. Although the summary judgment is supported alternatively on the grounds of release of liability and express assumption of risk, the trial court’s memorandum decision suggests the court also relied *668 on implied primary assumption of risk as a basis for summary judgment. This was unnecessary. In any case, Mr. Boyce’s express assumption of all risk provides adequate grounds to support the summary judgment. We need not, and do not, decide whether implied primary assumption of the risk applies to these facts. Summary judgment was properly granted.

We affirm.

Note 1. What does the court mean when it states: “Express assumption of risk arises out of a contract concept; implied primary assumption of risk arises out of a tort concept”? Do you understand the way these work in operation?

Note 2. What were the untaken precautions, if any, here? What would gross negligence have likely involved, on these facts? Is Scuba diving something that seems better suited to a strict liability regime? Why or why not?

Note 3. The *Tunkl* factors (at p. *664 in the opinion) are judicial factors for determining whether an exculpatory clause is void for reasons of public policy. Although the court does not technically reach them (and thus does not methodically apply them), it does embed references to a couple of the factors in its dicta. Look the *Tunkl* factors over again. How would you characterize the concerns they reflect? Which of tort law's purposes do they seem to support? Given that this is an area of considerable overlap between tort and contracts, you may be able to see ways in which contract law's prioritization of the parties' intent and mutually beneficial promises take precedence over tort law's central purposes.

Note 4. Normatively, is the ruling in *Boyce v. West* the correct result, in your view? Why or why not?

Scroggs v. Coast Community College Dist., Court of Appeal, 4th District, California (1987) (239 Cal.Rptr. 916)

Maurine Scroggs, plaintiff and surviving spouse of Frank W. Scroggs, appeals a summary judgment entered against her in her wrongful death action against Coast Community College and Barry Bandaruk. She contends the trial court erred in finding a release and waiver, executed by her husband before his death, bars the action as a matter of law. We agree and reverse.

In September 1982 Frank Scroggs enrolled in a scuba diving class offered by Coast Community College, and in that connection executed a release prepared by Coast. The following February, during a class certification dive, Frank drowned. The release provides for the participant to waive any claims “[he or his] heirs, representatives, executors and administrators thereof ... have or may have against the said The Coast Community Colleges [*sic*] or any or all of the above mentioned persons ... by reason of any accidents, illness, injury or death, or other consequences arising or resulting directly or indirectly from participation in SCUBA diving under the auspices of the Coast Community Colleges occurring during said participation, or any time subsequent thereto.”

Following the death of her husband, Mrs. Scroggs filed a complaint against Coast Community College and Barry Bandaruk, the class instructor, alleging the death of her husband by drowning was a result of defendants' negligence. Defendants answered the complaint asserting a release as an affirmative defense and then moved for summary judgment. On December 3, 1985, the trial court granted the motion and judgment was entered in favor of both defendants and against plaintiff. This appeal followed.¹³² [***]

Scroggs cites two California cases in support of her position that the court erred in finding the release binding. *Earley v. Pacific Electric Ry. Co.* (1917) 176 Cal. 79 [167 P. 513] held a release executed by an injured party in favor of a tortfeasor did not bar a later action by the releasor's heir. The court found the wrongful death statute, section 377 of the Code of Civil Procedure,¹³³ was not a survivorship statute

¹³² Scroggs urges error on three grounds in this appeal. In the light of our holding we reach only one.

¹³³ All statutory references are to the Code of Civil Procedure unless otherwise noted.

but rather “creates a new right of action with a different measure of damages from that which accrued to the injured person as a result of the defendant’s wrongdoing.” (*Id.*, at p. 81.) As such, the cause of action could not be waived by the decedent. [***] The effectiveness of a release to bar a wrongful death action was recently considered in *Coates v. Newhall Land & Farming, Inc.* (1987) 191 Cal.App.3d 1 [236 Cal.Rptr. 181]. In *Coates*, the decedent executed a release expressly assuming the risk of injury and waiving liability for injuries or death resulting from Newhall’s ordinary negligence. Without any analysis of section 377, the *Coates* court concluded “a decedent’s preinjury contractual assumption of risk eliminates the possibility of tortious conduct by a potential defendant, and thus precludes a wrongful death action, if (1) the contract is not against public policy and (2) the risk encountered by the decedent is inherent in the activity in which the decedent was engaged, or the type of risk the parties contemplated when they executed the contract. (*Id.*, at p. 4.)

The absence in *Coates* of any analysis of section 377 can only be justified by the court’s conclusion that the express contractual assumption of the risk, combined with the express waiver of defendants’ negligence, constituted a complete defense to the surviving heirs’ wrongful death action. This is different than holding the action is barred. The failure to draw a distinction between facts giving rise to a complete defense to a wrongful death action, and facts precluding a wrongful death action, tends unnecessarily to obfuscate a clear and uncomplicated chain of decisional law concerning the nature and effect of California’s wrongful death statute.

It is axiomatic that a plaintiff in a wrongful death action is subject to defenses which could have been asserted against the decedent. (See, e.g., *Hasson v. Ford Motor Co.* (1977) 19 Cal.3d 530, 552 [contributory negligence]; *Barnett v. Garrison* (1949) 93 Cal.App.2d 553, 557 [assumption of the risk]; *Nakashima v. Takase* (1935) 8 Cal.App.2d 35, 38 [justifiable homicide].) But these defenses neither preclude nor destroy the wrongful death action. If it were possible to destroy a wrongful death action in advance, then arguably a decedent should be able to do so by a release drawn in general terms such as the one here.

The longstanding rule is that a wrongful death action is a separate and distinct right belonging to the heirs, and it does not arise until the death of the decedent. (*Earley v. Pacific Electric Ry. Co.*, *supra*, 176 Cal. at p. 81.) Since *Earley* the courts have consistently articulated this principle and have validated it in a variety of circumstances. (See, e.g., *Garcia v. State of California* (1967) 247 Cal.App.2d 814, 816 [fact that prisoner is barred from suit alleging injuries from dangerous condition is no bar to action for wrongful death by surviving spouse]; *Blackwell v. American Film Co.* (1922) 189 Cal. 689, 693-694 [prior judgment in favor of decedent for injuries does not bar later action for wrongful death]; *Marks v. Reissinger* (1917) 35 Cal.App. 44, 54 [statute of limitations runs from date of death, not injury of decedent].)

The wrongful death action was created by the Legislature, and apart from amendments affecting damages, the statute establishing the action has remained virtually unchanged since its enactment in 1862. Exceptions to the rule that the action is not derivative should be made by the Legislature, not the courts. Any contract, intending to limit or destroy a cause of action which belongs to the heirs, should be construed with an abundance of caution. ... In the release prepared by Coast Community College, there is no language indicating the decedent intended to assume all risks of the activity, nor does the release encompass a waiver of defendants’ negligence. The presence of a clear and unequivocal waiver with specific reference to a defendant’s negligence is a distinct requirement where the defendant seeks to use the agreement to escape responsibility for the consequences of his negligence...

The trial court here found *McAtee v. Newhall Land & Farming Co.* (1985) 169 Cal.App.3d 1031 and *Hulsey v. Elsinore Parachute Center* (1985) 168 Cal.App.3d 333 to be controlling. Both cases involved claims by plaintiffs who were injured after engaging in activities offered by the defendants. And in both the plaintiffs had executed releases giving up their right to sue for injuries sustained. But neither case involved a wrongful death action by an heir. The sole issue was the validity of the release under Civil Code section 1668. While there is a similarity between those cases and the instant one in that motorcycling, parachuting and scuba diving all involve risks, this similarity provides no basis for upholding the release against Scroggs.

Furthermore, it is of no moment that scuba diving is of little public importance and serves no significant public purpose. Contracts seeking to release in advance the right to bring a wrongful death action, are not binding on the decedent's heirs, and there is no compelling reason to create an exception in the case of so-called "sports risk" cases. A surviving heir of a sports enthusiast is entitled to the same protection as the surviving heir of the victim of an automobile accident. If the decedent has provided the defendant with a partial or total defense, the defendant may assert it in response to the lawsuit. The release in this case fails to provide defendants with such protection.

The judgment is reversed. Appellant is entitled to costs on appeal.

Note 1. The court distinguishes between when a release of liability ("express contractual assumption of the risk") may provide a defense versus when it may bar an action. Can you see the difference? Why did it not bar the action in this case?

Note 2. Wrongful death statutes. The wrongful death statute in California controlled Mrs. Scroggs' right to sue. What theories of tort law are served by allowing her to do so in this case? Keep in mind this does not mean she automatically wins this case, but simply that the defendant may not use summary judgment, with no other defenses, to defeat her claim. This is the Washington state wrongful death statute:

RCW 4.20.010 Wrongful death—Right of action.

(1) When the death of a person is caused by the wrongful act, neglect, or default of another person, his or her personal representative may maintain an action against the person causing the death for the economic and noneconomic damages sustained by the beneficiaries listed in RCW 4.20.020 as a result of the decedent's death, in such amounts as determined by a trier of fact to be just under all the circumstances of the case.

(2) This section applies regardless of whether or not the death was caused under such circumstances as amount, in law, to a felony.

RCW 4.20.020 Wrongful death—Beneficiaries of action.

Every action under RCW 4.20.010 shall be for the benefit of the spouse, state registered domestic partner, child or children, including stepchildren, of the person whose death shall have been so caused. If there is no spouse, state registered domestic partner, or such child or children, such action may be maintained for the benefit of the parents or siblings of the deceased.

In every such action the trier of fact may give such damages as, under all circumstances of the case, may to them seem just.

Note 3. Wrongful Death and Tort Law’s Compensation Principle. Allowing recovery by those who have lost loved ones due to the negligence of others is one way that tort law seeks to deter careless behavior, to compensate for the injuries it causes, and to advance social justice, at least in some cases. But, as you will discover if you study damages later in your course, tort law’s means of advancing these purposes are limited. Occasionally, some sort of injunctive relief may be available but usually the approach to making someone whole for the loss of a person consists of remuneration (or “money damages”). Considering that financial compensation can only ever go so far in achieving this goal, should heightened liability standards apply with respect to wrongful death actions? Why or why not?

Check Your Understanding (4-1)

Question 1. An avid skier, Ari signs a release of liability to go helicopter skiing and experience the joy of taking a helicopter ride to remote, ungroomed terrain to go skiing in deep powder. When he is on his way there, the helicopter crashes and Ari is gravely injured. Whether he can sue will most depend on which of the following:

An interactive H5P element has been excluded from this version of the text. You can view it online here: <https://saidtorts2d.lawbooks.cali.org/?p=70#h5p-96>

Implied Assumption of the Risk

Landings Ass’n, Inc. v. Williams, Supreme Court of Georgia (2012) (291 Ga. 397)

***397** In *The Landings Association, Inc. v. Williams*, 309 Ga.App. 321, 711 S.E.2d 294 (2011), the Court of Appeals held that the trial court properly denied in part motions for summary judgment brought by The Landings Association, Inc., and The Landings Club, Inc., finding that a question of fact remained as to whether The Landings entities failed, pursuant to the law of premises liability, to take reasonable steps to protect Gwyneth Williams from being attacked and killed by an alligator in the planned residential community and golf club owned and/or managed by The Landings entities.¹³⁴ We granted certiorari to determine whether the Court of Appeals erred in reaching this

¹³⁴ The Landings Association owns and manages the common areas of the residential area, and The Landings Club owns and manages the golf course.

conclusion. Because the record shows that Williams had equal knowledge of the threat of alligators within the community, we reverse.

As is relevant to our holding, the facts, in the light most favorable to Williams, show that, at the time of the alligator attack, Williams was house-sitting for her daughter and son-in-law at The Landings, a planned residential development with a golf course located on Skidaway Island off the Georgia coast. Before The Landings was developed, the land within and surrounding its boundaries was largely marsh, where indigenous alligators lived and thrived. In order to develop the property, The Landings entities installed a lagoon system which allowed enough drainage to create an area suitable for a residential development. After the project was completed in the 1970s, the indigenous alligators subsequently began to move in and out of The Landings through its lagoon systems.

Although alligators inhabited the area of The Landings before and after its establishment, no person had ever been attacked until the night of October 5, 2007, when Williams, who was 83 at the time, *398 went for a walk near one of the lagoons near her daughter's home some time after 6:00 p.m. The following morning, Williams' body was found floating in the lagoon.¹³⁵ Williams' right foot and both forearms had been bitten off. Later, an eight-foot alligator was caught in the same lagoon, and, after the alligator was killed, parts of Williams' body were found in its stomach.

The record shows that, prior to the attack, Williams was aware that the property was inhabited by alligators. Williams' son-in-law testified that, on at least one occasion, he was driving with Williams on property in The Landings when he stopped the car to allow Williams to look at an alligator. Williams' son-in-law also testified that Williams was, in fact, aware that there were alligators in the lagoons at The Landings and that he believed that Williams had a "normal" respect for wild animals. When asked whether he had ever discussed how to behave around wild alligators with Williams, her son-in-law responded: "No. There was never—quite frankly, there was never any reason to. I mean she was an intelligent person. She would—there was no question in my mind that—I guess I have to answer that as it's not like talking to a five year old child ... stay away from alligators." In addition, Williams' son recalled a similar instance when he stopped the car to allow his mother to look at an alligator. At that time Williams mentioned that she did not like alligators and did not want to go anywhere near them.

Generally, in premises liability cases,

[c] to survive a motion for summary judgment, a plaintiff must come forward with evidence that, viewed in the most favorable light, would enable a rational trier of fact to find that the defendant had actual or constructive knowledge of the hazard. At that point, the burden of production shifts to the defendant to produce evidence that the plaintiff's injury was caused by his or her own voluntary negligence (intentional disregard of a known risk) or causal negligence (failure to exercise ordinary care for one's personal safety). If the defendant succeeds in doing so, the burden of production shifts back to the plaintiff to come forward with evidence that creates a genuine dispute of fact on the question of voluntary or causal negligence by the plaintiff or tends to

¹³⁵ One side of the lagoon was a park-like area owned by The Landings Association, and the other side of the lagoon was part of the golf course owned by The Landings Club.

show that any such negligence resulted *399 from the defendant's own actions or conditions under the defendant's control. [cc]

Furthermore, it must be remembered that

“[t]he true ground of liability is the proprietor's superior knowledge of the perilous instrumentality and the danger therefrom to persons going upon the property. It is when the perilous instrumentality is known to the owner or occupant and not known to the person injured that a recovery is permitted.” [cc] One who is familiar with the premises cannot rely for recovery upon the negligence of the defendant in failing to correct a patent defect where such party had equal means with the defendant of discovering it or equal knowledge of its existence.” [cc]

[***] In this case, testimony shows that Williams was aware that wild alligators were present around The Landings and in the lagoons. Therefore, she had knowledge equal to The Landings entities about the presence of alligators in the community. In addition, the record shows that Williams knew that the wild alligators were dangerous, saying herself that she would not want to be anywhere near them. Nonetheless, Williams chose to go for a walk at night near a lagoon in a community in which she knew wild alligators were present. This act undisputably shows that Williams either knowingly assumed the risks of walking in areas inhabited by wild alligators or failed to exercise ordinary care by doing so. Under these circumstances, the trial court should have granted the motions for summary judgment brought by the Landings entities regarding Williams' premises liability claims.

The dissent, like the Court of Appeals, attempts to avoid this conclusion by arguing that summary judgment for The Landings is precluded because there is no “competent evidence that the decedent knew there were alligators over seven feet in size living in the community or living in the lagoon in which [Williams'] body was found.” While there is no doubt that Williams' death was a tragic *400 event, Williams was not incompetent. A reasonable adult who is not disabled understands that small alligators have large parents and are capable of moving from one lagoon to another, and such an adult, therefore, assumes the risk of an alligator attack when, knowing that wild alligators are present in a community, walks near a lagoon in that community after dark.

Judgment reversed.

BENHAM, Justice, dissenting.

I write because I respectfully disagree with the majority's opinion reversing the decision of the Court of Appeals to allow this premises liability case to go to a jury. The majority reasons that appellees' claims cannot survive summary judgment because the decedent had equal knowledge, as compared to appellants, that there were alligators in and around The Landings community. Premises liability cases, however, cannot be resolved on summary judgment unless “the evidence is plain, palpable, and undisputed.” [cc] In this case, the Court of Appeals was correct when it affirmed the trial court's denial of summary judgment to appellants because the evidence was not plain, palpable, and undisputed.

Notably absent from the majority's opinion are facts which, if construed in appellees' favor, require the denial of appellants' motions for summary judgment. For example, the Landings Association had an advertised policy that it removed from the 151 lagoons in the community alligators which were

seven feet long or larger and/or alligators which were aggressive toward humans or pets;¹³⁶ the appellants did not patrol or inspect the lagoons in order to remove large or aggressive alligators according to its policy, but rather relied on residents and employees to report said animals; and appellants did not post signs near the lagoons warning guests about alligators. [c] An expert opined that the over eight foot long, 130 pound alligator that attacked the decedent had likely been in the lagoon where the decedent's body was found for some time because such mature alligators tend to be territorial and nest. There was also evidence in the record that the decedent called for help during the attack, but that appellants' security forces, which were not trained in *401 dealing with alligators, responded to the wrong location and then stopped investigating, assuming that the sounds in question were bird calls. While there was some testimony that the decedent had seen at least one alligator standing on the side of the road in The Landings, the Court of Appeals concluded in its *de novo* review that there was no "competent evidence" that the decedent knew there were alligators over seven feet in size living in the community or living in the lagoon in which her body was found. [c]

[I]ssues of negligence, contributory negligence and lack of care for one's own safety are not susceptible of summary adjudication... but should be resolved by trial in the ordinary manner.... Where reasonable minds can differ as to the conclusion to be reached with regard to questions of whether an owner/occupier breached the duty of care to invitees and whether an invitee exercised reasonable care for personal safety, summary adjudication is not appropriate. [***]

Based on the facts presented at the time of summary judgment in this case, reasonable minds could differ as to the essential elements of appellees' premises liability claim. Indeed, there are very specific questions in this case that must go to a jury: whether decedent knew that large and aggressive alligators were living on the premises and in the lagoon in which her body was discovered;¹³⁷ and whether appellants exercised reasonable care in inspecting and keeping the premises safe from alligators—in particular, alligators that were over seven feet long and alligators that were aggressive toward humans and pets as per appellants' removal policy. Rather than allowing this evidence to be reviewed by a fact-finder, the majority opinion bars appellees' premises liability claim simply because the decedent once observed an alligator standing on the roadside. Such a result disregards all the other factual circumstances in the case and is not in keeping with our jurisprudence. [***] Accordingly, I would affirm the judgment of the Court of Appeals and allow the premises liability claim to be tried before a jury. *402 I am authorized to state that Chief Justice Carley and Presiding Justice Hunstein join in this dissent.

Note 1. Assumption of the risk arguments often hinge on a balance of what the plaintiff did and what they knew. Thus courts inquire into the plaintiff's conduct but also their likely knowledge. Do you agree with the majority opinion here that the fact that Mrs. Williams knew there could be alligators in the lagoon means that "she had knowledge equal to The Landings entities about the presence of alligators in the community"? What do you think of the court's reasoning regarding Williams' statement that "she would not want to be anywhere near them"? The court argues that this demonstrates that she knew alligators were dangerous and *chose* to take the risk of encountering them anyway,

¹³⁶ Alligators over eight feet long are more prone to be aggressive toward and/or attack humans.

¹³⁷ See, e.g., *George v. U.S.*, 735 F. Supp. 1524, 1535 (M.D.Ala.1990) (fact that appellant knew there were alligators in a recreational swimming pond did not mean appellant was aware of the eleven-foot alligator that attacked him).

intentionally disregarding a risk or failing to exercise ordinary care for her safety. How might you challenge this line of reasoning if representing the decedent?

Note 2. The majority opinion uses ableist language in characterizing the decedent as having assumed the risk: “A reasonable adult who is not disabled understands that small alligators have large parents and are capable of moving from one lagoon to another, and such an adult, therefore, assumes the risk of an alligator attack when, knowing that wild alligators are present in a community, walks near a lagoon in that community after dark.”

Can you see how it might serve a substantive purpose here? Does it seem effective, and whether or not it is, does it seem necessary?

Note 3. Why does the majority ignore the facts the dissent raises such as knowledge of larger alligators being aggressive, alleged failures to warn, or the security detail’s lack of training in alligator attacks? Does it seem credible that a human cry for help during an alligator attack would sound like bird calls? Premises liability is one of the areas in which defendants owe limited duties where the duty to act is bound up with the conduct that the law will require. Which opinion strikes the better balance, in your view, between determining this as a question of limited duty and implied assumption of the risk (as the majority does) versus as a question on which the defendant’s breach of care ought to have been considered, along with the subjective knowledge of the decedent?

Note 4. Who gets to say what counts as common knowledge? Does it matter whether the premises liability concerns local residents or tourists?

See <https://www.washingtonpost.com/news/morning-mix/wp/2016/08/23/tourists-warned-disney-of-alligator-minutes-before-toddler-was-killed-report-says/> (The family did not pursue legal action.) Not all courts would come out the same way on similar facts. As has likely been increasingly clear in your study of tort law, tort law varies a great deal by jurisdiction.

In *George v. U.S.*, 735 F. Supp. 1524, 1535 (M.D. Ala. 1990), the court went the other way, finding no assumption of the risk merely because the victim of an alligator attack on park maintained by the United States government knew alligators were present:

Mr. George testified that he knew alligators were present in Open Pond but that he was unaware that there were any the size of the reptile that took his arm. This Court finds by a preponderance of the evidence that Mr. George was not aware that an alligator approximately 11 feet in length inhabited the Open Pond waters. Furthermore, this Court finds that Mr. George had no knowledge of the danger presented by his entering the swimming area. Thus, this Court finds that Mr. George did not assume the risk of his injury by entering the swimming area on July 26, 1986, notwithstanding his knowledge of the presence of alligators in Open Pond.

On the one hand, you have seen that tort law makes distinctions all the time on the basis of factual differences. Perhaps the size of the alligator *should* matter normatively to liability for attacks it causes. On the other hand, how well does it serve tort law’s various purposes if litigation over serious injuries (or fatalities) such as these hangs on what seem like fairly trivial differences? Or if not trivial differences (three feet of alligator is actually not *trivial*), differences that seem rooted in something other than immutable legal principles?

**Kalter v. Grand Circle Travel, U.S. Dist. Court, Central District of California
(2009)
(631 F. Supp.2d 1253)**

Grand Circle is a tour operator that arranges vacation packages to destinations around the world. Jill Kalter (“Kalter”) purchased a Grand Circle “Amazon River Cruise & Rain Forest” tour, along with an optional post-trip extension to visit the Inca ruins at Machu Picchu. Prior to departing on her trip, Kalter received from Grand Circle an itinerary of the Machu Picchu trip extension (the “Itinerary”), which stated that her group would visit Machu Picchu on two consecutive *1256 days, and that on the second day she would have the option of remaining with a guide or exploring the ruins on her own. The Itinerary also stated: “[t]hese Inca sites are not like ancient squares in Europe; they are spread out over steep hillsides with large stone steps and uneven surfaces.... In the ruins, there are no handrails some places where you might like one.” Kalter received and read the itinerary prior to departing on her trip. In addition, the tour guide, Jesus Cardenas, distributed a map of Machu Picchu to the tour participants prior to entering the park.¹³⁸ The map includes a section entitled “Visit Regulations,” which states, among other things, “Do not climb the walls,” and “Follow only designated routes according to arrows.”

It was raining on both days Kalter was at Machu Picchu. The first day, she remained with Cardenas and walked on the stone paths. The second day, she opted to explore on her own, and ventured off the established paths. Cardenas states that he gave verbal warnings to the group to use caution due to wet and slippery conditions. Kalter states that she did not hear Cardenas give these warnings, but that she “has no reason to doubt” that he did so. Kalter went to an area known as the “terraces,” filled with vertical rock walls that contain small stone protrusions called “floating steps.” [***] Some of these terraces are along paths color-coded by length, and no paths at Machu Picchu require traversing floating steps. Approximately one hour after venturing out on her own, Kalter became lost and disoriented, and was concerned about connecting with her group so that she would not miss the train. In an effort to get a better view of where she was, Kalter stepped up onto the bottom two floating steps of a vertical wall. Kalter did not think this was a dangerous act. As a result, Kalter fell and suffered serious injuries, and is now a quadriplegic.¹³⁹

Grand Circle now moves for summary judgment on the grounds that: (1) Plaintiffs’ claims are barred under the doctrine of primary assumption of the risk; (2) Grand Circle had no duty to warn Kalter *1257 of the dangerous nature of the floating steps because it was open and obvious; and (3) Grand Circle is not liable for the actions of Cardenas because he is an independent contractor.

A. Primary Assumption of the Risk Bars Plaintiffs’ Claims.

“The question of the existence and scope of a defendant’s duty of care is a legal question which depends on the nature of the sport or activity in question and on the parties’ general relationship to the activity, and is an issue to be decided by the court, rather than the jury.” *Knight v. Jewett*, 3 Cal.4th 296, 313 (1992). The doctrine of primary assumption of the risk applies where “the defendant owes no legal

¹³⁸ The map is produced by the Peru National Institute of Culture, not Grand Circle.

¹³⁹ It is unclear exactly how Kalter fell, as she does not remember and there were apparently no witnesses. (Kalter Dep. 12:22–13:5.)

duty to protect the plaintiff from the particular risk of harm that caused the injury.” [c] To determine if primary assumption of the risk applies, courts look to the nature of the activity, and the parties’ relationship to that activity. [cc] The question turns on whether the plaintiff’s injury is within the “inherent” risk of the activity. [c] A risk is inherent to an activity if its elimination would chill vigorous participation in the activity and thereby alter the fundamental nature of the activity. *Knight*, 3 Cal.4th at 318. Accordingly, “the doctrine of primary assumption of risk applies where ‘conditions or conduct that otherwise might be viewed as dangerous often are an integral part’ of the activity itself.” [***] When primary assumption of the risk applies, a defendant is only liable for a plaintiff’s injuries “if the defendant ‘engages in conduct so reckless as to be totally outside the range of the ordinary activity involved in the sport or activity’ or increases the inherent risk involved in the activity.” If, on the other hand, “the defendant does owe a duty of care to the plaintiff, but the plaintiff proceeds to encounter a known risk imposed by the defendant’s breach of duty,” the doctrine of secondary assumption of the risk applies, which is analyzed under comparative fault principles. *Knight*, 3 Cal.4th at 315. In such a case, “the trier of fact, in apportioning the loss resulting from the injury, may consider the relative responsibility of the parties.” Here, Kalter was engaged in the activity of hiking on uneven terrain amongst ancient ruins. Inherent in this activity is the risk that one will fall and *1258 become injured. (See *Andia*, 2007 WL 4258634, at *5, 2007 U.S. Dist. LEXIS 88247, at *15) (holding that “falling is always a risk when engaging in any kind of strenuous hike on steep and uneven terrain”).

The Itinerary Kalter received prior to the tour informed her that the Inca sites at Machu Picchu “are spread out over steep hillsides with large stone steps and uneven surfaces.” (Itinerary 65.) Eliminating tour participants’ access to these large stone steps and uneven surfaces in an attempt to protect against the risk of falling would eliminate the ability to view the Inca sites, and thus “alter the fundamental nature of the activity.” See *Knight*, 3 Cal.4th at 318, 11 Cal.Rptr.2d 2, 834 P.2d 696. In other words, “hiking across uneven and challenging natural terrain is an inherent risk of hiking to [the ancient ruins at Machu Picchu], without which the general public would be substantially deprived of viewing the ... phenomenon.” See *id.* Moreover, as discussed further below, Kalter did not fall while engaging in the activities condoned by Defendants—she chose to leave the established stone pathway, and further endangered herself by stepping onto the floating steps. Accordingly, the Court finds that primary assumption of the risk applies to Kalter’s injuries from falling while hiking at Machu Picchu. Therefore, Grand Circle is only liable for Kalter’s injuries “if [it] engage[d] in conduct so reckless as to be totally outside the range of the ordinary activity involved in [hiking amongst ancient ruins on uneven terrain] or increase[d] the inherent risk involved in the activity.” [***]

Plaintiffs argue that Grand Circle breached its duty to Kalter by “encouraging and permitting her to roam the ruins of Machu Picchu on her own, then directing her to an area unknown, i.e. which was not explored with her Trip Leader the prior day, and given the conditions of that day, was dangerous and confusing.” Kalter was an experienced hiker, and prior to electing to explore the ruins on her own instead of remaining with Cardenas, she had read Grand Circle’s Itinerary informing her that she would encounter steep hillsides, large stone steps, and uneven surfaces. She also received the map from Cardenas which stated “Do not climb the walls” and “Follow only designated routes according to arrows.” Moreover, Plaintiffs do not dispute that visitors to Machu Picchu often wander the ruins on their own, and that park regulations do not prohibit them from doing so. In addition, Plaintiffs provide no evidence that Cardenas or Grand Circle knew Kalter would attempt to climb the floating steps, and do not dispute Cardenas’ statement that Kalter “never asked me if she could climb down from or up to any terraces. At no time did I tell Ms. Kalter that she should climb down or up the series of terraces,

and at no time did I tell Ms. Kalter that it would be okay for her to climb up or down the stone terrace walls or on the ‘floating steps.’” [c]

Given these undisputed facts, Grand Circle’s act of allowing Kalter to explore on her own areas she had not been to with Cardenas was not “so reckless as to be totally outside the range of ordinary activity” involved in the excursion, nor did it increase the inherent risk of falling and sustaining injury involved in hiking in this region. [cc] The Court also notes that other participants in the tour stated that Cardenas was “outstanding and the accident was not at all [his] fault. And of course, [Kalter] fell on a day of totally independent activities.” *1259

Moreover, even if Grand Circle or Cardenas erred in estimating Kalter’s ability to hike on her own across the uneven terrain at Machu Picchu in rainy weather, “an instructor’s assessment errors—either in making the necessarily subjective judgment of skill level or the equally subjective judgment about the difficulty of conditions—are in no way ‘outside the range of the ordinary activity involved in the sport.’” [c]; see also *Andia*, 2007 WL 4258634, at *5, 2007 U.S. Dist. LEXIS 88247, at *16 (holding that tour guide’s “decision to allow Plaintiff to return to the Rangers station alone [during a guided hike to a lava flow] ... at most constituted ‘assessment errors,’ but these ‘subjective judgments about the difficulty of the conditions were ‘in no way so reckless as to be totally outside the range of the ordinary activity involved’ in the activity of lava hiking”).

Plaintiffs have submitted a declaration by Alexander Anolik, a travel and tourism attorney, stating that Cardenas “failed to insist, explain the need for or put together a ‘buddy system’ whereby Ms. Kalter would not have to be in this strange and dangerous area by herself,” and contending that his conduct of allowing Kalter to explore on her own fell below the standard of care in the travel industry.

Anolik submits no case law or any other information to suggest that such conduct falls below a standard of care, or that any other tour companies or guides employ such practices. (See Supplemental Cardenas Decl. ¶ 3, stating that he is unaware of any other tour guide at Machu Picchu that requires a buddy system.) Further, as explained above, allowing tour participants to hike on their own, even off trail on uneven terrain, is not so reckless as to be totally outside the range of the ordinary activity involved in hiking. As such, the Court finds Anolik’s bare assertions insufficient to create a triable issue of fact regarding whether Defendants’ conduct was so reckless as to be totally outside the range of the ordinary activity or otherwise increased the inherent risk involved in the activity of hiking amongst ancient ruins in an undeveloped area. Accordingly, Grand Circle is not liable for Kalter’s injuries under the doctrine of primary assumption of the risk.

B. Grand Circle Had No Duty to Warn Kalter of the Open and Obvious Danger Posed by the Wet Floating Steps.

“It is established law, at least in the exercise of ordinary care, that one is under no duty to warn another of a danger equally obvious to both.” [***] Here, it was obvious to both Kalter and Cardenas that it was raining, and Kalter admitted at her deposition that she “knew [the stones] were slippery and wet.” Moreover, the danger of slipping and falling from stepping on a small wet stone step protruding from a vertical wall is undoubtedly an obvious danger. Plaintiffs conclusorily state that “there are genuine issues of material fact regarding whether the conditions that caused Ms. Kalter’s injuries were open and obvious,” but offer no evidence to support this claim. Indeed, Kalter admits that it was “raining on and off,” that she “knew the rocks could be slippery”, and that before she started climbing she could see the third step was missing. Kalter offers no evidence to suggest that she believed climbing the

floating steps was allowed or common, or that she saw anyone else climbing them. Further, it appears that *1260 the danger of climbing the steps was obvious to other members of Kalter's tour; when asked whether he saw anyone climbing the steps, one member responded, "Good Lord. Someone, probably the guide, said that the Indians might have used them." [***] Kalter also testified at her deposition that she "thought there would be some risk in climbing up the floating steps." Further, Plaintiffs offer no evidence that the risk of slipping on the wet floating steps was any less obvious to Kalter than to Cardenas, especially in light of the fact that Kalter had walked on stone with Cardenas the previous day and noted that the stone was "slippery at times."

Plaintiffs also cite case law holding that "although the obviousness of a danger may obviate the duty to warn of its existence, if it is *foreseeable* that the danger may cause injury despite the fact that it is obvious (e.g. when necessity requires persons to encounter it), there may be a duty to *remedy* the danger, and the breach of that duty may in turn form the basis for liability." [***] While a landowner may be required to remedy a dangerous but obvious condition on his property, the situation differs with regards to a tour guide and tour company, where, as here, the dangerous condition is neither on the guide or company's property nor within their control. [***]

Moreover, numerous courts have held that tour companies and guides have no duty to warn of obvious dangers their customers encounter on trips. *See, e.g., Tei Yan Sun v. Governmental Auths. of Taiwan*, 2001 U.S. Dist. 1160, at *31–32 (finding no liability for failure to disclose dangers of "severe undertow, high waves, and strong surf" at beach, and noting that travel agents have no duty to disclose obvious dangers to travelers) [c]; *Passero v. DHC Hotels & Resorts*, 981 F.Supp. 742, 744 (D.Conn.1996) ("A tour operator may be obligated, under some circumstances, to warn a traveler of a dangerous condition unknown to the traveler but known to it... This doctrine applies to situations where a tour operator is aware of a dangerous condition not readily discoverable by the plaintiff. It simply does not apply to an obvious dangerous condition equally observable by plaintiff.") ... Plaintiffs cite no cases in which courts have found tour companies or guides liable for failing to warn of or remedy open and obvious dangers.

Accordingly, the Court finds that Grand Circle had no duty to warn Kalter that the floating steps might be slippery and dangerous in the rain, as this danger was readily observable.

C. Since Neither Grand Circle Nor Cardenas Are Liable for Kalter's Injuries, the Court Need Not Reach the Issue of Whether Cardenas Is an Employee or Independent Contractor.

As explained above, neither Grand Circle nor Cardenas are liable for Kalter's *1261 injuries because the doctrine of primary assumption of the risk applies, and because neither had a duty to warn her of the open and obvious danger of falling while climbing wet stone steps protruding from a vertical wall. Further, Plaintiffs do not argue that Cardenas' actions after Kalter fell caused or contributed to her injury. As such, whether Cardenas is Grand Circle's employee or an independent contractor does not affect Grand Circle's liability, and the Court need not reach the issue.

For the foregoing reasons, the Court GRANTS Grand Circle's Motion for Summary Judgment.

Note 1. Does Kalter's conduct strike you as risky? If she had not suffered catastrophic injuries, would your answer be the same? Does your answer—regarding her conduct's reasonableness—change depending on *why* she climbed the floating steps? Recall that she was looking for her group, from which she had become disconnected. Would it make a difference if she were climbing them... a) to

retrieve an errant toddler who was in danger? b) to retrieve an errant pet chihuahua who was in danger? c) to get a better photo, citing the desire to take an “instaworthy” snap for her profile? d) on a dare, to prove to a friend that she could do so without “getting in trouble”? To what extent do (and should) the motivations behind our actions matter to the determination of reasonableness in tort law?

Note 2. When claims arise in particular cultural contexts different from those in run-of-the-mill torts cases, should cultural norms be taken into account? What do you make of Kalter’s being a tourist here and ignoring the advice not to climb the floating steps? Should she have known better, or is her foreignness partly an explanation for her decision to climb the steps? If the floating steps were considered sacred territory that the local indigenous community advocated against climbing here, would this be information that U.S. tort law should or should not consider in assessing the reasonableness of her conduct? What tort law doctrines, if any, might treat such information as relevant?

For many years, tourists were injured climbing Uluru—formerly known as Ayers Rock—in Australia and at least 37 people died climbing it. The challenges included dangerous winds, slippery rock faces and excessive heat (with summer temperatures as high as 116 Fahrenheit). Following the death of a tourist in 2018, authorities decided to close it for good. For years, the Anangu, traditional owners of the land, had urged visitors not to climb the rock, both because of the dangers associated with the climb and because of the spiritual significance it holds in their culture. <https://www.bbc.com/news/world-australia-50151344>

If indigenous culture and wisdom militates against a particular practice (such as climbing certain parts of the landscape) on lands it has traditionally owned, is their guidance all that different from a municipality that passes an ordinance regarding certain conduct? Could and should negligence per se be adapted to recognize indigenous rules and proscriptions?

Note 3. Primary and Secondary Implied Assumption of the Risk. Do you understand the difference between these two forms of assumption of the risk? Some commentators have treated the second form as effectively obsolete because of comparative fault, in which the court weighs the conduct of plaintiff and defendant both. Articulate the standard, or rule, associated with each of the kinds of assumption of the risk. What do you observe about them, in terms of what needs to be shown, and who will decide the issues?

The next case shows how concepts of vicarious liability and implied assumption of the risk can interact. While the court did *not* find a relationship giving rise to vicarious liability, you can see that the concept stretches beyond merely employer/employee. In *Wall v. Gill*, the issue is whether a beauty school is liable for the torts of its students as well as whether patrons of beauty schools (which often charge lower prices due to the fact that the beauticians-in-training are still in training) have assumed the risk.

Wall v. Gill, Court of Appeals of Kentucky (1950) (311 Ky. 796)

The appellant conducts a college of beauty culture where instruction is offered to those desiring to become beauticians. It is after a successful completion of the course at such a college and the passing of the examination required by the State that a person qualifies as a beautician. In order that the students

in these schools may receive practical experience, they are permitted to serve the public before they are licensed. According to the rules and regulations of the Kentucky State Board of Barber and Beautician Examiners, a school is not permitted to perform services for the public for a profit. The prices charged are limited to the costs of materials and supplies and are regulated by the Board. A regulation of the Board prohibits a registered beautician from rendering regular operator services in the schools and *797 limits their services to those incident to and for the purpose of instruction. The Board also requires signs to be displayed in the beauty school reading: 'School of Beauty Culture—Work Done Exclusively by Students.' Students must wear some insignia identifying them as such.

The appellee went to the school of the appellant to get a permanent wave. This work was performed by a student at the price prescribed by the State Board. The appellee testified that on two occasions she complained to the student that she was being burned and that he attempted to adjust the wave units. Thereafter she developed a severe head burn. Medical testimony was introduced to substantiate the appellee's claim of injury. The student operator and the proprietor deny that the burn, if any, was occasioned by the negligent manner in which the treatment was given. However, negligence does not become an issue in the case in view of our theory of it.

The controlling questions are whether a patron of a beauty college assumes the risk of injury; and whether the relationship between the operator of the college and a student is one which would impose vicarious liability. No case has been cited nor do we find one directly in point. In *Massa v. Wanamaker Academy of Beauty Culture, Inc., City Ct., 80 N.Y.S.2d 923*, the trial court instructed the jury to find for the defendant beauty school, if it believed the work on the injured plaintiff was performed by a student. In that case, however, there was a release signed by the patron exempting the school from liability resulting from injuries sustained from the work of the student. In the statement of facts, the court said:

'* * * In this connection, and in order to give its students actual experience in the field, the defendant, in its school, permits the public to submit themselves to students of the school, at the risk of the subject, with knowledge that the student is not a graduate beautician and liable to errors and mistakes. * * *'

The appellant argues that the relationship was not one which would render the instructor liable for the negligence of the pupil. Instead it is urged that, under the existing law, such a student is classified as one not *798 yet competent to engage in the practice of beauty culture and that a patron who accepts his services at a reduced cost assumes the risk arising out of such inexperience. The negligence alleged in the petition was not that of insufficient or improper instruction or supervision, but rather that the operation was negligently performed. In response to the appellant's contention, the appellee urges that, since the student was under the control of the operator of the school, he was a servant of the operator and therefore liability should attach.

It seems to us that under the facts of this case the appellee assumed the risk of the student operator's inexperience. This risk cannot be confined to less professional hair styling, but must include all the dangers which might result from treatment by one who is not yet qualified. Having assumed the risk, the patron cannot then impose liability on another.

Nor do we believe that the relationship here is of the nature that imposes vicarious liability. The school instructs the pupil in the art of beauty culture, for which it receives a fee. As a part of his schooling the student performs services for the public, but the school receives no profit therefrom. In the case of *Miller v. Garford Laboratories, 172 Misc. 567*, it was held that the students of a beauty school which

received a profit for their services were employees within the meaning of the workmen's compensation law. The opinion recognized, however, that a person could be an employee for the purposes of the compensation law and not occupy that relation within the meaning of the law of negligence. In the instant case we have not only a tort claim but also a situation in which the students' services do not result in the pecuniary gain of the school. Under the circumstances, the school is not liable for the negligence of its students.

The judgment is reversed, with directions to set it aside, and for proceedings consistent with this opinion.

Note 1. What does the court mean when it writes: "However, negligence does not become an issue in the case in view of our theory of it"? How would you articulate its theory of the case?

Note 2. What is the source of the negligence alleged? Can you imagine a claim against the beauty school itself? What would need to be alleged to make out such a claim? Why might it fail?

Note 3. Another rationale supplied for vicarious liability may be found in the Restatement:

It is negligence to use an instrumentality, whether a human being or a thing, which the actor knows or should know to be so incompetent, inappropriate, or defective, that its use involves an unreasonable risk of harm to others. Restatement (Second) of Torts § 307 (1965)

This is known as the "**dangerous instrumentality**" doctrine, and you have seen it explicitly in the *Landings* alligator case as well as implicitly in the second prong of the test for applicability of res ipsa loquitur (whether the instrumentality was under the control of the defendant). Would the dangerous instrumentality theory, if applied in *Wall v. Gill*, make out a better case for the plaintiff? Or is the beauty school not "using" an instrumentality (beauticians-in-training) at all, based on the way the school is structured? Based on what you have read about vicarious liability and its relationship to control, does it matter who uses the instrumentality, versus who has the capacity to control its use?

2. Contributory Negligence

The doctrine of contributory negligence is thought to originate in an early 19th century English case in which a plaintiff was "riding as fast as his horse could go" and could have avoided colliding with a pole in the road had he been riding at a reasonable speed. *Butterfield v. Forrester*, 103 Eng. Rep. 926 (1809). However, the defendant was negligent in having placed a pole across part of the public road, and the action thus originated against him. The trial judge instructed the jury to focus on the plaintiff's conduct and find whether "a person riding with reasonable and ordinary care could have seen and avoided the obstruction." On appeal, the court upheld the jury verdict for the defendant, announcing the rule that "one person being in fault will not dispense with another's using ordinary care for himself. Two things must concur to support this action, an obstruction in the road by the fault of the defendant, and no want [Editor's note, "want" means "lack" here] of ordinary care on the part of the plaintiff."

In one sense, the rule on contributory negligence reflects an underlying insistence on the causal nexus required for any tort action: if the defendant's conduct was not the proximate cause of the plaintiff's injuries, then it is unfair to force the defendant to compensate the plaintiff for them. Yet unlike

proximate cause, with its fact-sensitive, circumstance-examining inquiries, contributory negligence created a complete bar to recovery, at least at first. Over time, doctrines would evolve to “soften” these otherwise harsh outcomes, but the rule remained rather starkly “either/or” in its approach to liability. As a result, the majority of jurisdictions have now adopted comparative fault. It is still worth studying contributory negligence for the five jurisdictions that retain it and for an understanding of the evolution of 20th century tort law since the complex legislative and judicial decision making it involved is informative for understanding tort policy more generally.

Davies v. Mann, Court of the Exchequer (1842) **(10 M. & W. 546, 152 Eng. Rep. 588)**

At the trial, before Erskine, J., at the last Summer Assizes for the county of Worcester, it appeared that the plaintiff, having fettered the fore feet of an ass belonging to him, turned it into a public highway, and at the time in question the ass was grazing on the off side of the road about eight yards wide, when the defendant’s waggon [*sic*], with a team of three horses, coming down a slight descent, at what the witness termed a smartish pace, ran against the ass, knocked it down, and the wheels passing over it, it died soon after. The ass was fettered at the time, and it was proved that the driver of the waggon was some little distance behind the horses. The learned Judge told the jury, that though the act of the plaintiff, in leaving the donkey on the highway so fettered as to prevent his getting out of the way of carriages travelling along it, might be illegal, still, if the proximate cause of the injury was attributable to the want of proper conduct on the part of the driver of the waggon, the action was maintainable against the defendant; and his Lordship directed them, if they thought that the accident might have been avoided by the exercise of ordinary care on the part of the driver, to find for the plaintiff. The jury found their verdict for the plaintiff, damages 40s.

Godson now moved for a new trial, on the ground of misdirection.

LORD ABINGER, C.B. I am of opinion that there ought to be no rule in this case. The defendant has not denied that the ass was lawfully in the highway, and therefore we must assume it to have been lawfully there; but even were it otherwise, it would have made no difference, for as the defendant might, by proper care, have avoided injuring the animal, and did not, he is liable for the consequences of his negligence, though the animal may have been improperly there.

PARKE, B. * * * [A]lthough the ass may have been wrongfully there, still the defendant was bound to go along the road at such a pace as would be likely to prevent mischief. Were this not so, a man might justify the driving over goods left on a public highway, or even over a man lying asleep there, or the purposely running against a carriage going on the wrong side of the road.

Note 1. What’s the alleged breach of conduct, or “untaken precaution” here? What caused the accident, and who could have avoided it?

Note 2. Is the rationale convincing to you (“were it not so, a man might justify driving over goods left on a public highway, or even a man lying asleep there...”)?

Note 3. Contributory negligence was a rather harsh rule, in that it barred any actions against plaintiffs who were even the slightest bit negligent. Courts expressly placed the burden on the defendant to prove

negligence by the plaintiff (rather than forcing the plaintiff to prove a lack of negligence), and this helped mitigate the harshness of the rule somewhat. Still, other doctrines arose to “soften” or ameliorate the rule’s rigid, potentially unfair outcomes. One of these ameliorating doctrines was the doctrine of “**last clear chance**,” first articulated in *Davies v. Mann*. When the plaintiff’s negligence would ordinarily bar an action but the defendant was the last person capable of avoiding the accident, the law deems the defendant to have had the “last clear chance” of preventing injuries and thus limits or negates altogether, the defense of contributory negligence. Some commentators have held that it is nothing more than a version of proximate cause (or intervening force) analysis: the defendant’s actions (or failure to act) effectively serve as a superseding cause that severs the chain of causation between the plaintiff’s own negligence and the acts of the defendant. The last clear chance doctrine is irrelevant (and often abolished) in jurisdictions that underwent reform and abandoned the doctrine of contributory negligence. But it provides a good example of how tort law’s principles of fair allocation and its inquiries into the causal nexus recur throughout many doctrines, in many different postures.

**Haugh v. Jones & Laughlin Steel Corp., Seventh Circuit Court of Appeals
(1991)
949 F.2d 914, 916**

This is an appeal (long delayed by virtue of the defendant’s bankruptcy and the resulting automatic stay only recently lifted) from a judgment for the defendant entered upon a directed verdict in the second trial of a diversity personal-injury suit. The first trial ended in a jury verdict of \$85,000 for the plaintiff, but the district judge granted the defendant’s motion for a new trial on the basis of an improper communication by the marshal to the jury during the jury deliberations. The evidence was somewhat different at the second trial and persuaded the judge to grant the defendant’s motion for a directed verdict (which he had denied at the first trial) on the twin grounds that the defendant had owed no duty of care to the plaintiff and that, in any event, the evidence showed conclusively that the plaintiff had been contributorily negligent—which at the time of the accident was a complete defense to liability.

Indiana has since replaced contributory negligence with comparative negligence, whereby a plaintiff’s own negligence is only a partial defense unless that negligence is adjudged more than 50 percent responsible for the accident; but the statute*916 is not retroactive. [cc] The plaintiff’s appeal seeks reinstatement of the first jury’s verdict on the ground that the grant of a new trial violated Rule 606(b) of the Federal Rules of Evidence, and alternatively a new trial—a third trial—on the ground that the grant of a directed verdict was improper because a reasonable jury could have found that the defendant owed the plaintiff a duty of care and that the plaintiff was not contributorily negligent.

At the time of the accident, in 1980, John Haugh was employed by Eichleay Corporation, which had a contract with Jones & Laughlin Steel Corporation to furnish workers and materials for making repairs at J & L’s mill in East Chicago, Indiana. Haugh’s particular job was to remove any generator needing repairs and replace it with a steel shaft (weighing almost a ton) to maintain a connection with the remaining generators, and then in turn to remove the shaft when the generator was ready to be reinstalled after having been repaired. It was in the course of his removing a shaft that the accident occurred. Although the contract between Eichleay and J & L gave Eichleay complete responsibility for the removal of generators and shafts incidental to the repair function for which it had been hired, the

practice was for employees of J & L, not of Eichleay, to do the preliminary rigging. So when on the day of the accident Haugh approached the shaft that he had been ordered to remove, he found as usual that most of the bolts connecting the shaft to the generator had already been removed and a chain hoist had been affixed to a choke (cable) that had been wrapped around the shaft.

Unfortunately, the cable had not been tightened around the shaft; it had no choking action. Haugh didn't notice this, and when, having removed the remaining bolts, he drew on the chain hoist to pull the shaft out from between the generators, the shaft slipped out of the cable and fell on him, injuring his arm. He had long experience in the job and admitted on cross-examination at both trials that if he had looked closely at the rigging he would have seen it was defective. The suit is against J & L for the negligence of its employees in rigging the shaft improperly, suit against Eichleay being barred of course by the workers' compensation statute.

[Judge Posner discusses improper communications by the court marshal at the lower court that tainted the jury's verdict and requires a new trial.] [***] So the judge was right to grant a new trial and the next question is whether he was also right to grant a directed verdict for the defendant. We think not. The argument over this question has been immensely confused by J & L's insistence on invoking the intricate rules of tort liability of landowners. [***] Those rules concern the concept of duty. Negligence is the breach of a duty of care; so there must be a duty before there can be a finding of negligence.

There is much old and some new learning on the range of duties that landowners owe the various categories of entrants onto their land—trespassers both adult and child and both deliberate and inadvertent, licensees, social guests, business invitees, public officers engaged in the performance of their duties, and so on. Haugh was a business invitee. The rule used to be that a landowner was liable for injury to a business invitee caused by a dangerous condition on the land only if the landowner had superior knowledge of the danger. The rule has been changed—in Indiana by *Douglass v. Irvin*, 549 N.E.2d 368, 370 (Ind.1990), which as we read it assimilates the landowner's duty in such a case to the general duty to avoid negligence.

The question in the present case, however, is not whether J & L provided a safe place for Eichleay to perform the services for which it had been hired. We may assume that it did. The question is not whether J & L as a landowner was responsible for the negligence of its independent contractor. It was not. That is the general rule, *Howard v. H.J. Ricks Construction Co.*, 509 N.E.2d 201, 205 (Ind.App.1987), and none of the exceptions is applicable here. *Anderson v. Marathon Petroleum Co.*, 801 F.2d 936 (7th Cir.1986).

Haugh's theory of liability is different. It is that employees of J & L negligently rigged the shaft that Haugh had been told by his own employer to move. For this negligence by employees of J & L, to which the site of the accident and hence J & L's status as a landowner is irrelevant and its duty of care simply the duty that everyone has (prima facie) to avoid a careless act that injures another person, J & L is liable under the doctrine of respondeat superior unless Haugh was contributorily negligent or some other defense to liability is in play (none is). It makes no difference that the contract between J & L and Eichleay assigned responsibility for the rigging to Eichleay. If you undertake an activity, whether or not you are required to do so, you must carry it through nonnegligently. [cc]

Haugh's contributory negligence would be a complete defense, but it is not proved merely by evidence that he could have prevented the accident by inspecting the rigging. Accident victims almost always can as a matter of physical possibility prevent accidents to themselves. Pedestrians could wear helmets,

or refuse to cross at intersections if there was any traffic even if the light was with them, or cower *920 at home. The failure to protect oneself from an accident is contributory negligence only if there is a duty to protect oneself in the particular circumstances, which means only if due care requires self-protection in the circumstances. [c]

Whether it did here remains unclear despite Haugh's concessions on cross-examination. Ordinarily a person is not deemed contributorily negligent for failing to take precautions against the negligence of others. [c] The plaintiff "was not bound to anticipate danger and negligent conditions on the part of defendant or his employees.... He had a right to presume that he was not exposed to danger which could come to him only from a breach of duty by the defendant." [***] The plaintiff's duty is to take the care that is due given the risk of unavoidable accidents, that is, accidents that might occur even without negligence [c]. Otherwise, the more careless people were, the greater would be the duty of their potential victims to protect themselves against carelessness. The burden of responsibility for taking care would shift from the careless to the careful and the total costs of accidents and accident prevention would rise. If J & L's riggers had been careful, there would have been no need for Haugh to inspect the rigging himself before moving the shaft. He was not—not as a matter of law, anyway—charged with responsibility for backstopping the exercise of care by the employees of another employer. [c]

These are matters for a jury to sort out. The record does not disclose so one-sided a case of contributory negligence as to entitle the judge to take the issue from the jury. So, unfortunately, there must be a third trial unless—as we hope—the parties can settle the case on the basis of the information furnished by two trials (one to verdict) and this appellate decision.

REVERSED AND REMANDED.

Note 1. This opinion, by renowned judge and legal scholar, Richard Posner, illustrates the way in which understanding both old and new rules in a given area can be important, and it also gives you a sense of how doctrine-heavy some complex contemporary cases can be, requiring that you seamlessly move from doctrine to doctrine as you analyze the facts. The Court of Appeals for the Seventh Circuit adopted comparative negligence during the pendency of the litigation, yet it cannot be applied in the instant case and thus contributory negligence remains the applicable rule here. Further, Posner discusses the shift from the traditional duty rule (with its tripartite structure of duties to entrants on land) to the modern California approach (applying a duty of reasonable care to all entrants). Now in Indiana the duty to entrants on land is not specified by entrants' status but consists instead of the duty of reasonable care. Lastly, Posner mentions three important work-place tort principles or doctrines: Haugh cannot recover against his employer, Eichleay, for on-the-job injuries because that is the province of workers' compensation; vicarious liability may apply because J & L will be liable for the torts of their employees if the relevant tests are satisfied; and there is ordinarily no vicarious liability to the hiring party (J & L) for the torts of their independent contractor (Eichleay) unless the independent contractor falls under one of the four main exceptions to the rule. Working through opinions that present a thicket of doctrines is excellent practice for the complex litigation landscape of many of your upper-division law school classes and characteristic of contemporary litigation-oriented legal practice.

Note 2. Why does Judge Posner believe remand is necessary?

Note 3. One of the rules in this case is: “Ordinarily a person is not deemed contributorily negligent for failing to take precautions against the negligence of others.” What does this mean, substantively, and procedurally?

Check Your Understanding (4-2)

Question 1. Judge Posner likely would have resolved *Haugh* in favor of J & L Steel if which of the following had been true (select the option *most* likely to have caused a ruling in favor of J & L Steel):

An interactive H5P element has been excluded from this version of the text. You can view it online here: <https://saidtorts2d.lawbooks.cali.org/?p=70#h5p-97>

Contributory Negligence and 20th Century Tort Reform

Contributory negligence’s dominance first began to recede in 1910 when the state of Mississippi became the first in the United States to depart from the traditional rule. However, change was slow. By the 1960s, only 7 states had adopted comparative fault, the modern alternative. It took a seismic change (and significant multi-industry lobbying) in the 1980s to effectuate broad tort reforms, but 39 more states ultimately adopted some version of comparative fault, sometimes through legislative action, sometimes through judicial opinions. Only four states (Alabama, Maryland, North Carolina and Virginia) and the District of Columbia retained contributory negligence, and these five jurisdictions remain distinctly in the minority today.

There are different types of comparative fault: **pure comparative fault** (adopted in some form by Alaska, Arizona, California, Florida, Hawaii, Kentucky, Louisiana, Mississippi, Missouri, New Mexico, New York, Rhode Island, and Washington) and **modified comparative fault** (adopted by all the rest in one version or another). There are two primary types of modified comparative fault. Roughly a dozen jurisdictions follow the so-called **50 percent Bar Rule** according to which the plaintiff may not recover if they are 50% or more responsible for their own injury (and at 49% or less, the regular comparative fault rules would apply). The remaining states follow the **51 percent Bar Rule**, which is what it sounds like: the plaintiff may not recover if they are 51% or more responsible for their own injury. The two systems differ only if the plaintiff is found to be exactly 50% at fault. (Both would allow recovery at 49% and both would bar it at 51%.) You can see this focus on “roughly 50%” as an extension of the preponderance of the evidence rule, which requires that the parties meet their burdens of proof by around a 51% probability. It may seem a little arbitrary in its execution, but it’s an attempt to retain some of the deterrence and fairness principles behind the old contributory negligence rule without retaining its starkly polarized outcomes.

The system overall displays tort law's sometimes maddeningly jurisdiction-specific quirkiness. For instance, the differences in the system mean that a car accident that occurs in Kansas City, which straddles two states, is subject to different rules if it happens on the Missouri side of the central river (where the rule is pure comparative fault) versus the Kansas side (where the rule is modified comparative fault). Should tort law's outcomes be allowed to vary so greatly, even when they are based on the very same facts, set in nearly identical settings? Or should uniformity be more prominent in efforts to achieve tort law's purposes? Alternatively, is the choice to allow jurisdictions to set their own rules one of the ways of achieving and tailoring tort law's purposes? Perhaps absurd results along borders can always be expected in our system of federalism unless Congress acts to federalize the question. These policy issues were all in the backdrop as tort reform made its way steadily through the courts and legislative bodies in the second half of the 20th century.

Comparative fault is a more complicated topic than we can fully cover in an introductory torts class, in that it involves procedural questions, substantive issues governing liability (and immunity thereto) and allocational complexities. For instance, should liability be determined by the comparative fault of the parties? If so, is the proper means of measuring and comparing the fault of the parties the *level of breach* of conduct, that is, assessment of whether one party's conduct is considerably more unreasonable? Or should it be measured by the *level of causation*, such that even if a first party's *breach* was more egregious, if a second party's breach contributed more substantially to *causing* the harm, or to increasing the risk or amount of harm, that second party would bear a higher share of the fault? And to what extent should differing levels of *duty*, as well as different justifications for *proximate cause* and different immunities all factor in when evaluating comparative fault? This is all focusing on liability alone.

A second critical question is whether the apportionment of damages should mirror the level of fault used to determine liability. Whether or not to do so—rather than trying to parse out which damages were actually caused by particular acts of unreasonable conduct—may depend on how the comparative fault is analyzed in the first stage. It is worth remembering something we have discussed, in passing, a few times, but not yet fully considered: there are typically two parts to a trial. First, a liability determination, and second, a damages determination. Sometimes, these may be discussed at the same time in a bifurcated trial, but often, they are decided one after the other. Can you see how the system of comparative fault will make the issues difficult to keep distinct? Comparative fault arose as a means to soften contributory negligence. However, in many states, it came in with, or shortly before, a wave of tort reforms that addressed perceptions that tort law was unfairly allocating liability awards to the parties able to pay, regardless of their level of contribution. In particular, joint and several liability became a target of reform, with many states either abolishing or limiting joint liability as being incompatible with comparative fault.

3. Comparative Fault

Rodriguez v. City of New York, Court of Appeals (2018) (31 N.Y.3d 312)

***315** This appeal requires us to answer a question that has perplexed courts for some time: Whether a plaintiff is entitled to partial summary judgment on the issue of a defendant’s liability, when, as here, defendant has arguably raised an issue of fact regarding plaintiff’s comparative negligence. Stated differently, to obtain partial summary judgment in a comparative negligence case, must plaintiffs establish the absence of their own comparative negligence. We hold that a plaintiff does not bear that burden.

Plaintiff Carlos Rodriguez was employed by the New York City Department of Sanitation (DOS) as a garage utility worker. He was injured while “outfitting” sanitation trucks with tire chains and plows to enable them to clear the streets of snow and ice. The following facts are uncontradicted: On a snowy winter day, plaintiff and his two coworkers were tasked with outfitting sanitation trucks with tire chains and plows at the Manhattan 5 facility. Typically, the driver backs the truck into one of the garage bays, and the driver and other members of the team “dress” the truck. One person acts as a guide, assisting the driver by providing directions through appropriate hand signals while standing on the passenger’s side of the truck. Once the truck is safely parked in the garage, the driver, the guide, and the third member of the team (here, plaintiff) place chains on the truck’s tires.

At the time of his accident, plaintiff was standing between the front of a parked Toyota Prius and a rack of tires outside of the garage bay while the driver began backing the sanitation truck into the garage. The guide, at some point, stood on the *driver’s* side of the sanitation truck while directing the driver in violation of established DOS safety practices. The sanitation truck began skidding and eventually crashed into the front of the parked Toyota Prius, propelling the car into plaintiff and pinning him up against the rack of tires. Plaintiff was taken to the hospital and ultimately had to undergo spinal fusion surgery, a course of lumbar epidural steroid injections, and extensive physical therapy. He is permanently disabled from working.

***316** Plaintiff commenced this negligence action against the City of New York. After discovery, he moved for partial summary judgment on the issue of defendant’s liability pursuant to CPLR 3212. Defendant opposed the motion and cross-moved for summary judgment in its favor. Supreme Court denied both motions. In denying plaintiff’s motion for partial summary judgment, Supreme Court held that there were triable issues of fact regarding foreseeability, causation, and plaintiff’s comparative negligence. [fn]

The Appellate Division granted plaintiff leave to appeal to this Court [c] certifying the following question: “Was the order of Supreme Court, as affirmed by this Court, properly made?” [fn]

317** Whether a plaintiff must demonstrate the absence of his or her own comparative negligence to be entitled to partial summary judgment as to a defendant’s liability is a question of statutory construction of the CPLR. [] Article 14–A of the CPLR contains our State’s codified comparative negligence principles. CPLR 1411 provides that

“[i]n any action to recover damages for personal injury, injury to property, or wrongful death, the *318 culpable conduct attributable to the claimant or to the decedent, including contributory negligence or assumption of risk, *shall not bar recovery*, but the amount of damages otherwise recoverable shall be diminished in the proportion which the culpable conduct attributable to the claimant or decedent bears to the culpable conduct which caused the damages.” (Emphasis added.)

CPLR 1412 further states that “[c]ulpable conduct claimed in diminution of damages, in accordance with [CPLR 1411], shall be an affirmative defense to be pleaded and proved by the party asserting the defense.”

Placing the burden on the plaintiff to show an absence of comparative fault is inconsistent with the plain language of CPLR 1412. In 1975, New York adopted a system of pure comparative negligence, and, in so doing, directed courts to consider a plaintiff’s comparative fault only when considering the amount of damages a defendant owes to plaintiff. The approach urged by defendant is therefore at odds with the plain language of CPLR 1412, because it flips the burden, requiring the plaintiff, instead of the defendant, to prove an absence of comparative fault in order to make out a prima facie case on the issue of defendant’s liability. [fn]

*319 Defendant’s approach also defies the plain language of CPLR 1411, and, if adopted, would permit a possible windfall to defendants. [***] For example, assuming in a hypothetical case a defendant’s negligence could be established as a matter of law because defendant’s conduct was in violation of a statute (*see* PJI 2:26) and further assuming plaintiff was denied partial summary judgment on the issue of defendant’s negligence because plaintiff failed to establish the absence of his or her own comparative negligence, the jury would be permitted to decide the question of whether defendant was negligent and whether defendant’s negligence proximately caused plaintiff’s injuries. If the jury answers in the negative on the question of defendant’s negligence, the plaintiff would be barred from recovery even though defendant’s negligence was established as a matter of law and in contradiction to the plain language of *320 CPLR 1411. Such a windfall to a defendant would violate section 1411’s mandate that a plaintiff’s comparative negligence “shall not bar recovery” and should only go to the diminution of damages recoverable by plaintiff. Furthermore, it is no answer to this conundrum that the trial court could set aside the verdict. The whole purpose of partial summary judgment is to streamline and focus the factfinder on the issues that need resolution, and avoid having juries make findings that are contrary to law.

Defendant’s attempts to rely on CPLR 3212’s plain language in support of its preferred approach are also unavailing. Specifically, defendant points to CPLR 3212(b), which provides; “[a] motion for summary judgment shall . . . show that there is no defense to the cause of action.” Defendant’s approach would have us consider comparative fault a defense. But, comparative negligence is *not* a defense to the cause of action of negligence, because it is not a defense to any element (duty, breach, causation) of plaintiff’s prima facie cause of action for negligence, and as CPLR 1411 plainly states, is not a bar to plaintiff’s recovery, but rather a diminishment of the amount of damages.

The approach we adopt is also supported by the legislative history of article 14–A. [***] Article 14–A’s enactment was proposed by the 1975 Judicial Conference of the State of New York (the Conference) in response to this Court’s decision in *Dole v. Dow Chemical Co.*, 30 N.Y.2d 143, 331 N.Y.S.2d 382, 282 N.E.2d 288 [1972]), which first provided for the apportionment of negligent

responsibility among joint tortfeasors. In proposing the section which later became CPLR 1411, the Conference specifically noted that neither the defense of contributory negligence or assumption of risk “shall continue to serve as complete defenses” in negligence actions [c]. In proposing the section which became CPLR 1412, the Conference urged the adoption of the then-majority rule in this country, which provided that “in all negligence actions ... the defendant claiming contributory negligence of the plaintiff has the burden of showing it” (*id.* at 245). The Conference also observed that the “burden of pleading and burden of proof are usually parallel” and that “[t]his article may be viewed as having created a partial defense, the effect of which is to mitigate damages, and *321 such defenses traditionally must be pleaded affirmatively” (*id.* at 246).

[***] The purpose of the law was to bring “New York law into conformity with the majority rule and represents the culmination of the gradual but persistent erosion of the rule that freedom from contributory negligence must be pleaded and proven by the plaintiff” [c]. The legislative history of article 14–A makes clear that a plaintiff’s comparative negligence is no longer a complete defense and its absence need not be pleaded and proved by the plaintiff, but rather is only relevant to the mitigation of plaintiff’s damages and should be pleaded and proven by the defendant. [***]

*323 Plaintiff contends, even assuming there is an issue of fact regarding his comparative fault, that he is entitled to partial summary judgment on the issue of defendant’s liability. [***] We agree with plaintiff that to obtain partial summary judgment on defendant’s liability he does not have to demonstrate the absence of his own comparative fault.

We also reject defendant’s contention that granting the plaintiff partial summary judgment on defendant’s liability serves no practical purpose. A principal rationale of partial summary judgment is to narrow the number of issues presented *324 to the jury [fn]. In a typical comparative negligence trial, the jury is asked to answer five questions:

1. Was the defendant negligent?
2. Was defendant’s negligence a substantial factor in causing [the injury or the accident]?
3. Was plaintiff negligent?
4. Was plaintiff’s negligence a substantial factor in causing (his or her) own injuries?
5. What was the percentage of fault of the defendant and what was the percentage of fault of the plaintiff? (PJI 2:36).

Where plaintiff has already established defendant’s liability as a matter of law, granting plaintiff partial judgment eliminates the first two questions submitted to the jury, thereby serving the beneficial purpose of focusing the jury on questions and issues that are in dispute.

Nor do we agree with defendant that what it characterizes as bifurcation of the issues of defendant’s liability from plaintiff’s liability runs counter to the Pattern Jury Instructions. [***] As a practical matter, a trial court will instruct the jury in a modified version of Pattern Jury Instruction 1:2B that the issue of defendant’s negligence, and in some cases, the related proximate cause question, have been previously determined as a matter of law. Trial courts are experienced in crafting such instructions, for example when liability has already been determined in a bifurcated trial, or when an Appellate Division upholds a liability determination and remands solely for a recalculation of damages, or a trial on damages has been ordered pursuant to CPLR 3212(c).

To be entitled to partial summary judgment a plaintiff does not bear the double burden of establishing a prima facie case of *325 defendant's liability and the absence of his or her own comparative fault. Accordingly, the order of the Appellate Division, insofar as appealed from, should be reversed, with costs, and the case remitted to the Appellate Division for consideration of issues raised but not determined on the appeal to that Court and the certified question answered in the negative.

GARCIA, J. (dissenting).

The majority holds that plaintiff's motion for partial summary judgment on liability was improperly denied, notwithstanding issues of fact as to plaintiff's comparative negligence. We disagree. The rule has been, and should remain, that a plaintiff must demonstrate the absence of issues of fact concerning both defendant's negligence and its own comparative fault in order to obtain summary judgment. [c]

Plaintiff's injury occurred while he was working in a New York City Department of Sanitation garage, as he and his colleagues outfitted sanitation trucks with tire chains and a plow in order to clear snow and ice from the City streets. With the storm ongoing, plaintiff's colleagues were backing a truck into the Department's garage bay when the truck slid several feet and hit a parked car, which skidded forward and hit plaintiff.

Supreme Court rejected both parties' summary judgment motions. In rejecting plaintiff's motion, the court found that there were triable issues of fact as to the City's liability, specifically with respect to causation and foreseeability, as well as plaintiff's comparative fault. The court noted that "[f]oreseeability questions are generally left for the fact finder to resolve" (citing *Derdiarian v. Felix Constr. Corp.*, 51 N.Y.2d 308, 315, 434 N.Y.S.2d 166, 414 N.E.2d 666 [1980]) and that numerous issues of fact remained concerning causation. In addition, the court found that even if defendant's liability was established, "plaintiff would not be entitled to summary judgment as to liability since the question of his comparative fault must be resolved at trial." [***]

Attempts have been made to amend the comparative fault statute to place on a defendant opposing summary judgment "the burden of interposing proof of culpable conduct" (*see* S. 20572017–2018 Reg Sess [NY 2017]; S 7779/2016–2017 Reg Sess [NY 2016]; [c]). Such attempts at legislative reform would be unnecessary if plaintiffs were entitled to summary judgment despite the existence of issues of fact concerning comparative fault. As defendant points out, these proposed bills would still preclude summary judgment where "defendant presents evidence of plaintiff's comparative fault sufficient to raise a question of fact" after a plaintiff has demonstrated defendant's liability as a matter of law (*see* Assembly Mem. in Support, H 2776 [2017]). The majority's approach goes well beyond these proposals, enabling a plaintiff to obtain summary judgment even where, as happened here, a defendant *329 has demonstrated that plaintiff's comparative fault may be significant.

[***] Determinations of degrees of fault should be made as a whole, and assessing one party's fault with a preconceived idea of the other party's liability is inherently unfair; or, as the Appellate Division characterized it, a defendant would "enter[] the batter's box with two strikes already called" (142 A.D.3d at 782, 37 N.Y.S.3d 93). Indeed, as the Appellate Division also noted, the Pattern Jury Instructions advise that a jury consider both parties' liability together (*see* PJI 2:36).

This is because the issues of defendant's liability and plaintiff's comparative fault are intertwined. A jury cannot fairly and properly assess plaintiff's comparative fault without considering defendant's actions (*see e.g.* Siegel, Practice Commentaries C 3212:24 [noting that "(n)o purpose (is) served by

the granting of summary judgment” where “the proof that would go into the damages question substantially overlaps that on which liability depends”). [***]

Simultaneous consideration by the jury of both parties’ level of culpability is also the more practical approach. Indeed, “few, if any, litigation efficiencies are achieved by the entry of partial summary judgment in this context because the defendant would still be entitled, at trial, to present an all-out case on the plaintiff’s culpable conduct” [c]. In the event that plaintiff obtained partial summary *330 judgment without removing issues of comparative fault, a jury would still be required to assess plaintiff’s degree of liability, and then make a damages determination in a subsequent proceeding. [***] The majority promotes its approach by pointing to the “eliminat[ion]” of the first two questions a jury must answer in a “typical comparative negligence trial” [c]. But these questions would not be eliminated by a grant of partial summary judgment, as an assessment of defendant’s negligence would be required in order for the jury to determine comparative fault and damages.

Nor is our approach barred by the statutory language of CPLR article 14–A. Requiring a plaintiff to show freedom from comparative fault in advance of obtaining summary judgment does not “bar recovery” in derogation of article 14–A. Before the enactment of Article 14–A, a plaintiff was unable to obtain recovery of any sort where he or she was in any way culpable (*Fitzpatrick v. Int’l. Ry. Co.*, 252 N.Y. 127, 133–34 [1929] [“At common law a person has no cause of action for negligence, if he himself has contributed, in the slightest degree, to bring it about”]). Article 14–A enables a plaintiff to *recover* despite comparative fault [c]. It does not mandate that courts grant partial summary judgment on liability to plaintiffs who are comparatively at fault, as the majority’s approach would require. The comparative fault statute simply provides that a plaintiff is entitled to recover a certain amount of damages, to be determined by a jury, even in cases where plaintiff has engaged in some degree of culpable conduct. This requires that each party’s culpability be assessed and liability determined before judgment is granted [c] [“(W)hat the statute requires comparison of is not negligence but conduct which, for whatever reason, the law deems blameworthy, in order to fix the relationship of each party’s conduct to the injury sustained and the damages to be paid by the one and received by the other as recompense for that injury”]).

*331 The majority repeatedly speaks to the “double burden” our approach would place on defendant. But there is no unfair tipping of the scales. Plaintiff in his moving papers made a blanket assertion of freedom from any comparative negligence and defendant, in response, came forward with extensive evidence of plaintiff’s comparative fault. Plaintiff’s burden was merely that placed on any party moving for summary judgment—to demonstrate a lack of triable issues of fact. In that, plaintiff failed.

Order, insofar as appealed from, reversed, with costs, case remitted to the Appellate Division, First Department, for consideration of issues raised but not determined on the appeal to that Court and certified question answered in the negative.

Note 1. What are the two opinions disagreeing over? Put in your own words what would come next, in the litigation, under each of the two opinions. What values or methods seem to underlie the differences of opinion?

Note 2. Identify at least one of the purposes of summary judgment referenced in the opinions. Can it be reconciled with tort law’s various purposes, and, in particular, with its preference for fact-tailored determination of most of the elements of negligence?

Note 3. What do you notice about how the two opinions each characterize the facts? What does this tell you about how to craft statements of fact in service of a position of advocacy? At a minimum, precise factual description is important both because it can be hotly contested and because of how it can be strategically framed. Consider the following characterizations of fact from the two *Rodriguez* opinions at the appellate level, whose majority denied the plaintiff's summary judgment motion (holding that plaintiff had to prove absence of comparative fault). What differences do you observe?

Facts (Majority): [I]n the present case, plaintiff was injured when a sanitation truck backed into a Toyota Prius that then struck plaintiff. Defendant claims that plaintiff, an employee of defendant, while working outside the sanitation garage, was not supposed to walk behind a sanitation truck moving in reverse, and thus contributed to the cause of the accident. At his deposition, plaintiff testified that as the truck was backing up slowly, he was walking towards the front of the Prius, which was stationed behind the moving truck. Plaintiff stated that he took approximately 10 steps forward before the impact. It would appear that plaintiff was injured while walking behind a truck slowly moving backwards which he was not supposed to do. There is no evidence in the record that plaintiff was merely "standing" in front of the Prius when he was struck, as asserted by the dissent. Further, the evidence shows that the truck was moving in reverse at approximately five miles per hour when it skidded on snow/ice and struck the Prius. Under this factual scenario, the trier of fact could determine that defendant was free from negligence and that plaintiff was 100% at fault in causing his injuries.

Facts (Dissent): On a snowy day in January 2011, plaintiff and two coworkers, employees of defendant New York City's Department of Sanitation (DOS), were tasked with placing tire chains on sanitation trucks to provide better traction in the snow. While plaintiff was waiting for his coworkers to bring another truck into the garage for outfitting with chains, he walked towards the garage, between a parked car and a rack of tires. Plaintiff allegedly suffered injuries when his coworkers backed the truck into the parked car, which was propelled into him. The driver testified that, as he moved the truck in reverse, the "guide man" stood on the driver's side (he should have been guiding from the passenger's side, according to an accident report by a DOS safety officer) and gave an abrupt signal to stop, at which point the driver hit the brakes hard enough that he "jerked the truck" and slid into the car. The guide man testified that he started signaling from the passenger's side, as required, and moved to the driver's side only after it appeared that the driver was unable to see him signaling to stop. The guide man further testified that he signaled several times to stop, but the driver did not brake until the guide man moved to the driver's side and began waving his arms and yelling.

Check Your Understanding (4-3)

Question 1. Summary judgment exists primarily for the purposes of:

An interactive H5P element has been excluded from this version of the text. You can view it online here: <https://saidtorts2d.lawbooks.cali.org/?p=70#h5p-98>

Question 2. In *Rodriguez v. City of New York*, the majority seeks to avoid placing a “double burden” on the plaintiff by requiring that the plaintiff prove not just negligence by the defendant but also the plaintiff’s own lack of comparative negligence. In supporting its arguments, which of the following kinds of evidence does the court draw on?

- (i) Custom evidence
- (ii) Legislative history
- (iii) Statutory language

An interactive H5P element has been excluded from this version of the text. You can view it online here: <https://saidtorts2d.lawbooks.cali.org/?p=70#h5p-99>

Question 3. Which of the below is an accurate statement regarding the burden-shifting devices about which you have learned?

An interactive H5P element has been excluded from this version of the text. You can view it online here: <https://saidtorts2d.lawbooks.cali.org/?p=70#h5p-100>

Comparative Fault’s Intersection with Joint and Several Liability

White v. Diva Nails, Court of Appeals of Michigan (2020) (Unpublished opinion 2020 WL 3476744)

*1 Plaintiff Jill White appeals as of right the trial court’s order granting summary disposition in favor of defendants Diva Nails, LLC, and Nails Studio (collectively, defendants). We reverse.

On April 19, 2016, plaintiff claims to have received a manicure at Diva Nails in Livonia. She testified that during the manicure, the nail technician cut the skin on plaintiff's right thumb with cuticle clippers, breaking the skin and causing a small bleed. She alleged that the technician, who was not wearing gloves, did not disinfect the cut or ask plaintiff to wash her hands before finishing plaintiff's manicure. On April 23, 2016, plaintiff visited Nails Studio in Howell, Michigan for a polish change¹⁴⁰ and a pedicure. The technician was identified during discovery. According to plaintiff, that technician reopened the cut received at Diva Nails on plaintiff's right thumb with cuticle clippers, causing her wound to bleed and did not use any disinfectant on the cut or ask the Plaintiff to wash her hands. The technician denies that the wound was re-opened but admits that she wore one glove on her left hand. The technician from Nails studio denied being diagnosed with any communicable disease.

On April 26, 2016, plaintiff went to Livonia Urgent Care because the cut on her right thumb was inflamed and painful. Plaintiff was diagnosed with a bacterial infection and given antibiotics. After another visit to Livonia Urgent Care and two visits to St. Joseph Mercy Livingston Hospital, plaintiff was diagnosed with Herpes Whitlow and prescribed antiviral medication. Herpes Whitlow is a type of the Herpes Simplex Virus. The Herpes Simplex Virus is broken down into two types: Herpes Simplex and Herpes Simplex 2. Herpes Simplex 2 generally presents in the form of genital herpes, whereas Herpes Simplex 1 usually presents in the form of oral infections such as cold sores. While 50% to 80% of the general population have Herpes Simplex 1, an "extremely low" percentage of the population has Herpes Whitlow. The incubation period for the Herpes Simplex Virus is 1 to 26 days. Herpes Whitlow can be passed through the skin, saliva, from oral or anal sex, and by touching an open wound. Once a person contracts Herpes Whitlow, that person becomes a carrier of the virus for the rest of her life. A carrier of Herpes Whitlow can be asymptomatic her entire life and not know that she has the virus. Only a blood test can definitively show that a person is a carrier of Herpes. Plaintiff experienced an outbreak on September 1, 2016, but has not experienced anymore outbreaks since then.

Plaintiff's expert witness, Dr. Michael McIlroy, testified that plaintiff suffered a "very severe outbreak" and "will be considered infectious to others even when she does [not] have any active lesions." In Dr. McIlroy's opinion, plaintiff "definitely" contracted Herpes Whitlow at one of the nail salons. Dr. McIlroy could not determine whether plaintiff contracted the virus from Nails Studio or Diva Nails, but the timing of plaintiff's outbreak and the location of the nail injury indicated that the likelihood that plaintiff contracted the virus from one of the nail salons is "extremely high." As to how plaintiff would have contracted the virus, Dr. McIlroy testified as follows: *2 "At one of the salons, one of the workers had the herpes simplex [virus], more likely than not, and through the nail injury, transmitted their virus or the virus on the instrument to [plaintiff] and the cutting of her finger made it even a higher likelihood that she would acquire [H]erpes [W]hitlow because of the injury." No other expert witness opined as to the origin or cause of Herpes Whitlow.

Plaintiff filed a complaint against defendants, alleging negligence under an alternative-liability theory. After discovery both defendants filed motions for summary disposition under MCR 2.116(C)(10), arguing that alternative-liability theory was no longer viable in Michigan because the 1995 tort reform abolished joint liability and that plaintiff could not prove causation. The trial court did not determine whether the 1995 tort reform and abolition of joint liability eliminated alternative liability in Michigan, but concluded that summary disposition was warranted, nonetheless, because plaintiff could not

¹⁴⁰ A polish change is different from a manicure because, generally, a polish change only involves removing the current nail polish and applying a new nail polish.

demonstrate causation. According to the trial court, plaintiff could have contracted Herpes Whitlow from anywhere, and therefore, summary disposition was warranted. Plaintiff's motion for reconsideration was denied, and this appeal followed.

Plaintiff argues that the trial court erred in granting defendants' motion for summary disposition because alternative-liability theory is still viable in Michigan and there is a genuine issue of material facts as to whether either defendant caused her injury. We agree.

ALTERNATIVE-LIABILITY THEORY

[***] At a minimum, the applicable threshold evidentiary standard to a plaintiff's proof of factual causation in negligence cases is that a causation theory must have some basis in established fact. ... Plaintiff concedes that she is unable to identify the actor who caused her injury, but contends that, under alternative-liability theory, she can satisfy the causation element.

***3** Under a theory of alternative liability, a plaintiff can overcome the causation element and shift the "burden of apportioning damages" by holding the defendants jointly and severally liable, as explained in the seminal case concerning alternative-liability theory in Michigan, *Abel v. Eli Lilly & Co.*, 418 Mich. 311, 317 (1984). *Abel* was a products liability case that involved the daughters (and their spouses) of women who had taken the drug DES, a synthetic estrogen product, during their pregnancies. Because the plaintiffs were unable to identify the manufacturer of the drug to which they were exposed, the plaintiffs sued all manufacturers of the drug by relying on alternative-liability theory. *Id.* at 318. By relying on this doctrine, the plaintiffs sought to "circumvent the traditional tort element of causation in fact" and hold all of the manufacturer-defendants jointly and severally liable. *Id.* The Supreme Court ruled in favor of the plaintiffs, holding that the plaintiffs who were unable to identify the drug manufacturer that harmed them ... "may take advantage of the burden-shifting feature of the alternative[-]liability theory to withstand summary judgment on the causation issue of the negligence claims." The Supreme Court described the legal doctrine as follows:

Also called "clearly established double fault and alternative liability," this procedural device shifts the burden of proof on the element of causation in fact to the defendants once an innocent plaintiff demonstrates that all defendants acted tortiously, but only one unidentifiable defendant caused plaintiff's injury. If the defendants cannot meet this burden and exculpate themselves, joint and several liability will be imposed.[c] [fn]

When the Supreme Court decided *Abel*, multiple tortfeasors that produced a single, indivisible injury were held jointly and severally liable. *Gerling Konzern Allgemeine Versicherungs AG v. Lawson*, 472 Mich. 44, 49 149 (2005). "This meant that where multiple tortfeasors caused a single or indivisible injury, the injured party could either sue all tortfeasors jointly or he could sue any individual tortfeasor severally, and each individual tortfeasor was liable for the entire judgment, although the injured party was entitled to full compensation only once." *Id.* The right of contribution—an equitable remedy available to concurrent tortfeasors—then allowed one tortfeasor to recover among or between other tortfeasors. The principle [*sic*] purpose of "'contribution' was to mitigate the unfairness resulting to a jointly and severally liable tortfeasor who had been required to pay an entire judgment in cases in which other tortfeasors also contributed to an injury

In 1995, the Legislature enacted tort reform measures, 1995 PA 161 and 1995 PA 249, and limited the availability of joint and several liability. The Legislature enacted several statutory provisions

specifically designed to allocate fault for damages among multiple tortfeasors by abolishing joint and several liability in most cases. [c] The tort reform statutes applicable in this case are MCL 600.2956, MCL 600.2957(1), MCL 600.2960(1), and MCL 600.6304.

MCL 600.2956 provides, in relevant part:

Except as provided in section 6304, **in an action based on tort** or another legal theory **seeking damages for personal injury, property damage, or wrongful death**, the liability of each defendant for damages is **several only and is not joint**.

MCL 600.2957(1) provides:

In an action based on tort or another legal theory seeking damages for personal injury, property damage, or wrongful death, the liability of each person shall be allocated under this section by the trier of fact and, subject to section 6304, **in direct proportion to the person's percentage of fault**. In assessing percentages of fault under this subsection, **the trier of fact shall consider the fault of each person**, regardless of whether the person is, or could have been, named as a party to the action.

MCL 600.2960(1) provides:

The person seeking to establish fault under sections 2957 to 2959 has the burden of alleging and proving that fault.

***4** MCL 600.6304 provides, in relevant part:

(1) In an action based on tort or another legal theory seeking damages for personal injury, property damage, or wrongful death **involving fault of more than 1 person, including third-party defendants and nonparties**, the court, unless otherwise agreed by all parties to the action, **shall instruct the jury to answer special interrogatories** or, if there is no jury, shall make findings indicating both of the following:

(a) The total amount of each plaintiff's damages.

(b) **The percentage of the total fault of all persons** that contributed to the death or injury, **including each plaintiff and each person released from liability** under section 2925d, regardless of whether the person was or could have been named as a party to the action.

* * *

(4) Liability in an action to which this section applies is **several only and not joint**. Except as otherwise provided in subsection (6), a person shall not be required to pay damages in an amount greater than his or her percentage of fault as found under subsection (1). This subsection and section 2956 do not apply to a defendant that is jointly and severally liable under section 6312.

* * *

(8) As used in this section, “fault” includes an act, an omission, conduct, including intentional conduct, a breach of warranty, or a breach of a legal duty, or any conduct that could give rise to the imposition of strict liability, that is a proximate cause of damage sustained by a party.

Defendants contend that alternative-liability theory is no longer viable in Michigan because joint and several liability is critical to the doctrine’s application and was abolished by the 1995 tort reform. Whether the 1995 tort reform expressly abolished joint liability and effectively eliminated alternate liability involves, in part, statutory interpretation ... Defendants are correct in that, except for cases where it was expressly preserved by statute,¹⁴¹ the liability of each tortfeasor is “several only” and “not joint.” MCL 600.2956; MCL 600.6304(4).

However, abolition of joint liability does not preclude a plaintiff from invoking alternative liability to seek recovery when she cannot identify which of multiple tortfeasors caused her injury. Each tortfeasor is now liable only for the portion of the total damages that reflect that tortfeasor’s percentage of fault. [c] Rather than hold multiple tortfeasors liable for the entire judgment, i.e., jointly liable, the trier of fact will determine each tortfeasor’s proportion of fault and extent of liability. MCL 600.2957(1); MCL 600.6304(1)(b). Even if the defendants are unable to exonerate themselves—after the burden of proving factual causation has shifted—defendants will only be liable for their proportion of fault, which the trier of fact will determine. MCL 600.2957(1); MCL 600.6304(1)(b). Simply, alternative liability is still feasible even though only several liability is available to a plaintiff in a case such as this one.

*5 Alternative liability was not available to a plaintiff *because* multiple tortfeasors could be held jointly and severally liable; it was available because multiple tortfeasors acted wrongfully, and the injured plaintiff is unable to establish which of the tortfeasors actually caused the injury. *Abel*, 418 Mich. at 334. Alternative-liability theory focuses on factual causation, not how, or in what proportions, the defendants will be held liable. The underlying principle of alternative liability is “to prevent the injustice of allowing proved wrongdoers to escape liability for an injury inflicted upon an innocent plaintiff merely because the nature of their conduct and the resulting harm has made it difficult or impossible to prove which of them has caused the harm.” *Id.* at 327 (citation and quotation marks omitted). Even without joint liability, the application of alternative liability fulfills the Legislature’s intent to require a plaintiff in a tort action with multiple defendants to establish sufficient facts that would enable the fact-finder to discern each person’s liability in direct proportion to their percentage of fault.

While alternative-liability theory does not relieve the plaintiff of the burden of establishing proximate causation, i.e., that defendants’ actions were the natural, probable, foreseeable causes of plaintiff’s contraction of Herpes Whitlow. Accordingly, a plaintiff is still required to present sufficient facts proving duty, breach, proximate causation, and damages.

[***] Having concluded that alternative-liability theory is still viable in Michigan, we conclude that the trial court erred when it granted defendants’ motions for summary disposition because plaintiff

¹⁴¹ MCL 600.6304(6) allows joint and several liability in certain medical malpractice cases. MCL 600.6312 allows joint and several liability in tort cases in which a defendant’s act or omission is (1) “a crime, an element of which is gross negligence, for which the defendant is convicted,” or (2) “a crime, an element of which is the use of alcohol or a controlled substance, for which the defendant is convicted and” that is a violation of one of certain enumerated laws.

presented sufficient evidence to create a genuine issue of fact regarding causation. For alternative liability to be applicable [in Michigan], the plaintiff must demonstrate three elements:

- (1) all the defendants acted tortiously,
- (2) the plaintiff was “harmed by the conduct of one of the defendants,” and
- (3) the plaintiff, through no fault of her own, is unable to identify which actor caused the injury. *Abel*, 418 Mich. at 331-332.

The second element requires plaintiff to “make a genuine attempt to locate and identify the tortfeasor responsible for her injury” and “bring before the court all the actors who may have caused the injury in fact.” *Id.* [c] Once a plaintiff has met all three requirements, she is relieved “of the traditional burden of proof of causation in fact.” In this case, the facts alleged by plaintiff and contained in the record compromise evidence from which a reasonable jury could conclude that both defendants acted tortiously. [c]

According to plaintiff, technicians from both salons cut the skin on her right thumb and failed to treat the cut with disinfectant or soap. Neither technician wore gloves on both hands or asked plaintiff to wash her hands after she was cut. Dr. McIlroy testified that the technicians improperly placed the burden on plaintiff to clean a wound that they caused. Defendants negligently exposed plaintiff to a communicable disease by failing to ensure that their employees wear gloves, do not expose clients to contagious viruses, adequately treat any open wounds, and otherwise work in a hygienic manner. [***] The timing of plaintiff’s injury in relation to her visits to the nail salons and the location of the injury indicated an “extremely high” likelihood that plaintiff contracted the virus from one of the nail salons. Dr. McIlroy testified that he was 99% certain that Diva Nails or Nails Studio was responsible for her injury. Dr. McIlroy’s testimony demonstrates that plaintiff contracted Herpes Whitlow from one of the two nail salons, and therefore, all possible actors who may have caused plaintiff’s injury were brought before the court.

*7 Plaintiff, through no fault of her own, is unable to identify which actor caused her injury. The technician from Nails Studio states that she has never been diagnosed with any form of the Herpes Simplex Virus. However, Herpes Whitlow can be asymptomatic and thus undetectable unless a blood test is performed. In addition, whether or not plaintiff’s technician at Nails Studio had the virus does not necessarily mean that Nail Studio or Diva Nails did not cause plaintiff’s injury. According to Dr. McIlroy, plaintiff could have contracted the virus at one of the salons, from her technician or from a worker transmitting the virus on the instrument used when plaintiff was cut. Thus, the injury making [*sic*] it even a higher likelihood that she would contract Herpes Whitlow. [***] Moreover, the actions of the technicians at defendants’ salons were nearly identical. Both technicians failed to wear gloves on both hands, cut plaintiff’s right thumb in the same location, failed to disinfect the cut, and failed to ask plaintiff to wash her hands.

Alternative-liability theory is applicable to this case because plaintiff can demonstrate the three threshold requirements. Accordingly, plaintiff is relieved of the burden of proving causation in fact, which now shifts to defendants. Plaintiff has demonstrated an inability to identify the nail salon which harmed her and may benefit from “the burden-shifting feature of alternative- liability theory to withstand summary [disposition] on the causation issue of the negligence claim[].” *Abel*, 418 Mich. at 339. As stated above, plaintiff is still obligated to present evidence proving all other elements of negligence, including proximate causation.

Moreover, plaintiff has presented substantial evidence from which a jury may conclude that, more likely than not, she would not have contracted Herpes Whitlow but for defendants' conduct. The trial court ignored Dr. McIlroy's expert testimony that plaintiff contracted Herpes Whitlow from one of the two nail salons and that both defendants acted negligently. While 50% to 80% of the population have Herpes Simplex 1, the trial court was incorrect in determining that Herpes Whitlow is common and thus there was no way to determine where plaintiff contracted the virus. To the contrary, Herpes Whitlow is very rare and is much more difficult to pass from one individual to another. The trial court decided a fact that can only be resolved by the jury. Thus, summary disposition was inappropriate.

We reverse the trial court's order granting defendants' motions for summary disposition and remand for further proceedings. We do not retain jurisdiction.

Cavanagh, J. (dissenting).

Plaintiff failed to establish that both nail technicians were infected with the herpes simplex virus, and thus, a jury could not conclude that more likely than not, but for their negligent conduct, plaintiff would not have contracted herpetic whitlow. [***] Accordingly, I would affirm the trial court's order granting summary disposition in favor of defendants Diva Nails, LLC, and Nails Studio. [***] Plaintiff's expert witness, Dr. Michael McIlroy, testified that he believed plaintiff acquired the herpes virus at one of the nail salons. But he did not know if, in fact, either nail technician actually had the herpes simplex virus. Nevertheless, in McIlroy's opinion "one of the workers had Herpes Simplex, more likely than not, and through the nail injury, transmitted their virus or the virus on the instrument to [plaintiff]"

McIlroy explained that the Herpes Simplex 1 virus is usually transmitted by saliva so the saliva of one of the herpes-infected nail technicians who performed either of plaintiff's nail procedures likely transmitted the virus to plaintiff. The technician could have touched her mouth and had saliva on her finger and then transmitted the virus to plaintiff through her open wound. McIlroy testified that it was unlikely that the instruments used by either technician were the source of transmission because the virus does not usually survive on an instrument.

...In my opinion, plaintiff failed to establish that a genuine issue of material fact existed on the issue whether either defendant caused her to contract Herpes Whitlow. Plaintiff contends that, while she cannot identify which nail technician caused her infection, she does not have to; instead, she can satisfy the causation element of her negligence claim using a theory of alternative-liability. Plaintiff relied on the testimony of her expert, McIlroy, to support her causation theory that a herpes-infected nail technician at either or both salons caused her to become infected with the herpes virus.

But plaintiff never proved that both nail technicians in fact had the Herpes Simplex virus to pass on to plaintiff. McIlroy was merely *speculating* A valid theory of causation must be based on facts in evidence. [c] Impermissible conjecture and mere speculation are insufficient to establish causation. [cc] [***] There is no record evidence establishing that the nail technicians were infected with the herpes virus. In fact, one of the nail technicians testified that she did not have the herpes virus. If neither nail technician had the herpes virus, how could they pass it on to plaintiff? Thus, plaintiff cannot demonstrate causation and her claim must fail. The issue whether the 1995 tort reform eliminated alternative liability need not be decided in this case. But even if an alternative liability theory is viable in Michigan, plaintiff's claim would fail.

Under a theory of alternative liability, a plaintiff could seek recovery for an injury although she could not identify which of multiple tortfeasors caused her injury. As explained in the case of *Abel v. Eli Lilly & Co.*, 418 Mich. 311 (1984), the doctrine was first formally recognized in a case involving a plaintiff who was shot at by two hunting companions but was only hit by one of them. *Id.* at 325-326. The plaintiff could not meet his burden of proving cause-in-fact because there was no way to determine which one of the two defendants more likely than not shot him, i.e., there was a 50% chance that either of the defendants shot him. *Id.* at 326. As a matter of policy, it was decided that the two proved wrongdoers should bear the burden of absolving themselves rather than depriving the innocent plaintiff of a remedy. *Id.* at 326-327. This theory of “alternative liability” was formally approved by the *Abel* Court, which held that certain requirements must be met before a plaintiff could rely on that theory of liability, including: (1) it must be shown that all the defendants acted tortiously; (2) that the plaintiff was harmed by the conduct of one of the defendants; and (3) through no fault of her own, the plaintiff is unable to identify which defendant caused the injury. *Id.* at 331-332.

In this case, to advance an alternative-liability theory plaintiff would have to prove that *both* nail technicians who performed services on her were infected with the herpes virus, and therefore, it was impossible to determine *which* nail technician actually transmitted the herpes virus to plaintiff. Like the case of the two hunting companions discussed in *Abel*—where both hunters negligently shot a bullet at the plaintiff but only one bullet struck him and caused injury—here, both nail technicians would have had to be infected with the herpes virus (like the two bullets) and negligently performed nail services (like the shooting) so as to transmit the herpes virus to plaintiff. It would then be impossible for plaintiff to determine which nail technician actually transmitted the herpes virus because both were infected with it. But, again, there is no evidence in this case that both nail technicians were infected with the herpes virus, and thus, the transmission of the herpes virus cannot be sourced back to both nail salon defendants. It is just as possible that neither, or only one, nail technician was infected with the herpes virus. Plaintiff could also have been exposed to herpes-infected saliva after leaving the nail salons with an open wound. Accordingly, I would affirm the trial court’s order granting defendants’ motions for summary disposition.

Note 1. What was the defendants’ argument regarding alternative liability?

Note 2. Why did the court reject the defendants’ theory?

Note 3. The majority opinion points out that the technicians at both salons acted in an identical manner. “Both technicians failed to wear gloves on both hands, cut plaintiff’s right thumb in the same location, failed to disinfect the cut, and failed to ask plaintiff to wash her hands.” Why could that evidence not be used to establish that it was unreasonable to expect that they would behave otherwise?

Note 4. Do you agree with the court that there needs to be a footnote informing the court’s readership of the meaning of a “polish change”? Do you think this is just the court being thorough, given that there is a plausible legal significance to the difference between a polish change and a manicure? Or might this suggest something about the sociology of the judiciary and perhaps the identities and habits of judges? Do you think members of most juries could define a “polish change” in the context of a dispute set in the nail care industry? Should it matter to us whether our judges and juries are out of touch with the lives of everyday Americans?

Note 5. Are you persuaded by the dissent’s use of *Summers v. Tice*? Is it correct in the analogy it draws between the negligent conduct in *Summers* (negligently shooting in the plaintiff’s direction)

and *White* (having herpes)? Or is the breach of care the combination of nicking the plaintiff and working without gloves in a situation where sanitary measures like gloves ought to be used? In what other ways can the two situations be analogized or distinguished?

Note 6. MCL 600.6304, which provides the rule to follow in Michigan when more than one person is at fault, includes consideration of “third-party defendants and nonparties.” What is the potential effect of doing so? If the total fault allocated includes tortfeasors whose contribution cannot be collected, or whose immunity from liability bars collection of an award of damages, has the plaintiff been fairly compensated under the tort system? What countervailing mechanisms can you imagine to redress this concern? What other priorities of tort law does this system reflect?

Chapter 23. Immunities

In addition to the defenses supplied by plaintiff's own behavior, the other main category of defenses pertains to the status of the defendant: immunities. Entire classes of defendants are immune from tort liability to particular classes of actors, or under particular circumstances. For example, parents are generally immune from suit by their children with respect to their everyday childrearing choices, employers are generally immune from suit by their employees (who must turn to workers' compensation when injured on the job), and judges are immune from lawsuit by parties before them. A number of formerly broad immunities (such as spousal immunity or immunity for charitable organizations) have either been eroded or abrogated over time. This is not an exclusive list of status-based immunities, but these are likely the most significant ones historically.

Immunity offers powerful protection from lawsuits, and analytically, it operates somewhat as duty does, that is, as a question of law intended to serve as a gatekeeping mechanism. However, just as was the case with duty, there may be factual questions embedded in determinations of immunity. (Recall that in *Farwell v. Keaton*, for instance, the court considered factual questions, such as the relationship between the boys, to determine the legal issue of duty.) Similarly, determining immunity may require resolution of underlying factual questions, such as whether a step-parent can avail himself of the same immunity as the parent in a given situation (*see Zellmer v. Zellmer*, 164 Wash.2d 147 (2008)), or whether governmental actors were acting in a particular capacity (say, as legislators) versus as managers or employees whose actions should be treated, for tort liability purposes, more like those of private citizens. Immunities are important in their own right as jurisdictional limitations and as substantive protections. They also may play an important role in the operation of comparative fault and allocating damages appropriately.

Immunities are also important because they are defenses that pertain to particular statuses but do not attempt to excuse the conduct of the immunized actor. In other words, it may be clear that an actor is a tortfeasor and the only thing stopping liability from attaching is this immunity. In that sense, immunities are very different from other defenses that may make the defendant's conduct *not wrongful* (as in the case of self-defense or consent) or that may make the conduct *only as wrongful as the plaintiff's* (as in a hypothetical case of comparative fault). With immunities, the conduct may or may not be wrongful; the point of the immunity is to shield the actor from having to submit to the exercise of that investigation into wrongfulness. Protecting against that inquiry is precisely what is thought to confer autonomy in the roles to which immunity attaches. Implicit in this is the concession that mistakes are part of the job—whether for governmental actors, judges or parents—and these mistakes, when made in the core of the function to which the immunity attaches, are not legally recognized mistakes. Because of the significant amount of power wielded by those whom the law immunizes categorically, it is important to pay close attention to the rationales offered for immunity as well as to the operation and impact of maintaining it.

1. Judicial Immunity

Duvall v. County of Kitsap, Ninth Circuit Court of Appeals (2001) (260 F.3d 1124)

[Editor's note: the facts and parties have been streamlined to edit the case for length; brackets indicate edits.]

Christopher Duvall brought this action against a superior court judge, Kitsap County, the County's Americans with Disabilities Act ("ADA") coordinator, the chairperson of the County's ADA committee, and the person who served as court administrator and court ADA coordinator. Duvall alleged that these defendants failed to accommodate his hearing impairment during the state court proceedings involving the dissolution of his marriage. Specifically, he contends that the defendants violated the ADA, Section 504 of the Rehabilitation Act, and the Washington Law against Discrimination (WLAD) by refusing to provide real-time transcription for his hearings.¹⁴² The district court granted summary judgment to all defendants as to all claims. Duvall appeals.

I. Background

Christopher Duvall is completely deaf in his left ear and has a severe hearing impairment in his right ear. Because he *1130 does not sign well enough to use American Sign Language or Signed English, Duvall's primary mode of receiving communication is through the written word. He wears custom-fitted hearing aids and is able to communicate effectively in one-on-one conversation in spoken English with the aid of visual cues and lip reading. He finds it extremely difficult, however, to follow a conversation in which he is not a participant. In such circumstance, he is unable to focus on a single speaker to study his facial expressions, body language, and lip movement; nor is he able to control the pace of the conversation, nor provide for a pause that would give him time to process the various aural and visual cues and interpret the speaker's message. Attempting to overhear or follow a conversation between others requires a great deal of concentration, and after approximately thirty minutes Duvall begins to suffer from tinnitus and headaches that further diminish his capacity to understand spoken communication.

In 1994 and 1995 Duvall was a party to a family law case in the superior court of Kitsap County, Washington involving the dissolution of his marriage. In his declaration, he states that he was initially able to participate meaningfully in several pre-trial hearings because the hearings were short, there was no oral testimony, and the discussion centered on written materials that he had reviewed prior to the hearing. Thereafter, however, he experienced difficulty in following the one pre-trial hearing that included extensive oral testimony. That hearing took place in courtroom 269, the courtroom designated for hearing-impaired individuals because of its small size, superior acoustics, and special equipment, including an assistive-listening device, for hearing-impaired individuals. Nevertheless, Duvall could not understand the testimony of his ex-wife, even though he knows her speech patterns very well. Subsequently, after he continued to experience difficulty understanding the proceedings in two further

¹⁴² Real-time transcription, also known as videotext display or close captioning, is a computer-aided transcription device that converts typing from the court reporter's stenographic machine into English language text displayed on a computer screen.

pre-trial hearings, Duvall realized that he would not be able to participate meaningfully when the case came to trial without some form of accommodation. He then contacted the U.S. Department of Justice and was advised that he should request videotext display from the ADA Coordinator for Kitsap County.

The parties dispute when Duvall first requested videotext display for his court proceedings. Duvall contends that he contacted Barbara Razy, the county's ADA coordinator, in April, 1995, and spoke to her several times in the six weeks preceding his trial about his need for accommodation. According to Duvall, he explained to Razy that he had examined the equipment in courtroom 269 and had concluded that it would not effectively accommodate his hearing impairment, and specifically requested real-time transcription for his trial, which was scheduled to begin in late June.

[When he called and Razy was out on vacation, Duvall asserts that he was directed to Madelyn Botta, Director of the Superior Court's administrative services and its ADA coordinator and that he spoke with her twice in mid-May. While the substance of their conversations is disputed, Duvall contends that he requested real-time transcription. Botta contacted Duvall's attorney and told him that the trial would be held in a courtroom equipped for the hearing impaired.] [***]

***1131** None of the court or county officials attempted to determine whether the facilities in courtroom 269 would accommodate Duvall's hearing impairment, or whether it would be possible to provide videotext display through a court-reporting service, although, according to Duvall, he had informed them that the accommodations provided in Courtroom 269 were inadequate, given the nature of his particular hearing problems.

The trial for the marriage dissolution action was held before Judge Leonard Kruse on June 21, 22, and 23 in courtroom 269. That courtroom was equipped with the "Telex Soundmate," an assistive audio system for hearing-impaired individuals. Duvall contends that this device was inappropriate for an individual like himself who uses hearing aids that are precisely adjusted to the user's hearing needs. Telex-Soundmate did not contain an inductive loop system that would transmit to Duvall's hearing aids and make use of their customized settings. He further declares that the facilities in courtroom 269 required him to remove his hearing aids and to use earbuds, which provided only general amplification and impeded the use of his natural hearing ability. By Duvall's account, requiring him to remove his hearing aids to use the inferior Soundmate system was equivalent to requiring a person with an artificial leg to remove the leg and use crutches.

Duvall's attorney made a motion to the court on the first day of trial requesting videotext display to accommodate Duvall's hearing impairment. Judge Kruse stated in his deposition that this was the first time that he had heard about Duvall's request for that accommodation. In any event, Judge Kruse denied the motion, stating,

[T]hat's the way humans happen to communicate, I guess up until a very recent time, with one another is orally. And I know that some courts in some places have the ability to have, in effect, an on-line screen available through the court reporter. We have not progressed to that technical degree in this county, and I can only assume that if Mr. Duvall wished to have that service available he can provide that service for himself.

Judge Kruse did, however, permit Duvall to move around the courtroom freely and position himself wherever he could best hear the proceedings. Duvall sat in the jury box for a portion of the trial. Although this permitted him to understand the witnesses somewhat better, he was unable to

communicate easily with his lawyer, who was sitting at the counsel table. He testified that he made extensive notes to preserve his thoughts for his lawyer, but that he missed the testimony that occurred while he was looking down to write notes.

When Duvall's ex-wife took the stand on the first day of trial, Judge Kruse stated that the parties and attorneys could move about the courtroom "unless it ... starts to be disconcerting in some regard *1132 or intimidating or something." Duvall states in his declaration that he interpreted this remark to imply that he was sitting too close to the witnesses, and moved several seats away from the witness box, putting him out of effective aural range of the witnesses and attorneys. According to Duvall, at this point he "gave up" and returned to his seat next to his attorney for the remainder of the trial. The intense concentration required to attempt to follow the proceedings resulted in exhaustion, headaches, and tinnitus, further impeding his ability to hear. In sum, Duvall avers that his hearing impairment prevented him from meaningfully participating in the trial.

A post-trial hearing was scheduled for August 11, 1995.

[Duvall, again requested videotext display at the upcoming hearing hand-delivering a letter containing his request on August 8 to both Razey and Botta. They responded on behalf of the County on the same day with a letter stating simply that the hearing would be held in Courtroom 269. Again, no county or court official made any effort to determine whether videotext transcription was available. Duvall moved for a mistrial at the August 11 hearing, based upon the court's failure to provide videotext display at the trial, and Judge Kruse denied the motion, stating that real-time transcription was not available in Kitsap County.]

At the time of Duvall's June trial, one of the county's court reporters was training to learn real-time transcription, and in fact had already demonstrated to Botta and several of the superior court judges how that process works. Duvall also submitted declarations of court reporters in Seattle who stated that they could have provided videotext display at the time of his trial.¹⁴³ Indeed, when Razey first contacted firms in Seattle and Tacoma in September 1995 as part of the investigation of Duvall's complaint to the county ADA grievance committee, she learned that these firms did, in fact, have the capacity to provide videotext display to the superior court in Kitsap County. Moreover, although Sandra Baker and Associates, an independent firm that provided much of Kitsap County's court-reporting services, had never provided videotext display prior to September 1995, when Kitsap County first requested this service on September 19, 1995, that firm also was able to accommodate the request. It provided videotext display for Duvall's post-trial court hearing three days later, and for the subsequent hearings.

The County's ADA grievance committee denied Duvall's grievance on October 6, and the Board of County Commissioners denied his appeal in late November. Duvall filed suit in federal district court under Title II of the ADA, Section 504 of the Rehabilitation Act of 1973, the Washington Law Against Discrimination (WLAD), and 42 U.S.C. § 1983 seeking declaratory¹⁴⁴ and compensatory *1133 relief.

¹⁴³ Editor's note: Seattle is in King County, to the East of Kitsap County (which covers Bremerton, Bainbridge Island and Poulsbo). For context, according to the 2010 census numbers, King County's population was 1.938 million; Kitsap County's was 251,133.

¹⁴⁴ In his complaint, Duvall requested a declaration "that defendants have unlawfully discriminated against Plaintiff by refusing to provide real time captioning for his dissolution of marriage proceedings." Because Duvall ultimately received real time transcription and the county now provides that service for hearing-impaired individuals, his claims

The suit named as defendants (1) Judge Kruse and court administrator and ADA coordinator Botta (collectively “the Superior Court defendants”) and (2) County ADA Coordinator Razey, County ADA committee chairperson Richardson, and the three members of the Board of County Commissioners (collectively “the County defendants”). [fn] The district court granted summary judgment to all defendants on all claims. Duvall now appeals.

II. Judicial Immunity

The district court granted summary judgment to Judge Kruse and court administrator Botta on the ground of judicial immunity. It is well settled that judges are generally immune from suit for money damages. [c] However, absolute judicial immunity does not apply to non-judicial acts, i.e. the administrative, legislative, and executive functions that judges may on occasion be assigned to perform. [c] We have identified the following factors as relevant to the determination of whether a particular act is judicial in nature:

- (1) the precise act is a normal judicial function;
- (2) the events occurred in the judge’s chambers;
- (3) the controversy centered around a case then pending before the judge; and
- (4) the events at issue arose directly and immediately out of a confrontation with the judge in his or her official capacity. [c]

We conclude that Judge Kruse was acting in a judicial capacity when he refused to accommodate Duvall. Judge Kruse testified that he first learned of Duvall’s request for videotext display on the first day of trial, when Duvall’s attorney brought a motion requesting videotext display. Following completion of the trial, Duvall requested a new trial because of the absence of videotext display during that proceeding. Duvall’s motions were made by his attorney while Judge Kruse was presiding over Duvall’s case. The judge stated that, when he ruled on the motion requesting videotext display, he did not consider Duvall’s request under the ADA. Instead, Judge Kruse considered only whether, as a matter of courtroom administration, the courthouse was able to provide videotext display without delaying the start of the trial. At the August post-trial hearing, Judge Kruse simply ruled that Duvall was not entitled to a new trial based upon the court’s earlier refusal to provide videotext display. Ruling on a motion is a normal judicial function, as is exercising control over the courtroom while court is in session. Judge Kruse is therefore entitled to absolute judicial immunity. [fn]

Judicial immunity is extended to “certain others who perform functions closely associated with the judicial process.” [c] “When judicial immunity is extended to officials other than judges, it is because their judgments are ‘functional[ly] comparab[le]’ to those of judges—that is, because they, too, ‘exercise discretionary judgment’ as part of their function.” *1134 [c] (*see also Greater Los Angeles Council on Deafness v. Zolin*, 812 F.2d 1103, 1108 (9th Cir.1987) (holding that “the lynchpin of both the judicial and quasi-judicial immunities” is that the acts in question are “an integral part of the judicial process”). Here, Botta was the superior court ADA coordinator as well as the court administrator. She concedes that she had ministerial authority to arrange courtroom accommodations for disabled individuals, but contends that, because she was entitled to determine whether Duvall would receive his

for declaratory relief are now moot. [c]. His suit for damages, however, is not. [c] We therefore discuss only the claims for damages.

requested accommodations only in consultation with the judge presiding over his case, she is entitled to quasi-judicial immunity.

For Botta's defense of absolute immunity to succeed, she must demonstrate that her decision to refuse videotext display was functionally comparable to the type of decision made by a judge [c]. Absolute immunity is "the exceptional case." [c] Although, in her deposition, Botta expressed uncertainty about the limits of her authority to provide accommodations, she admitted that, as the court's ADA coordinator, she was the appropriate person from whom to request accommodations. She further acknowledged that she made the decision to accommodate Duvall by scheduling his trial in Courtroom 269, rather than by providing him with videotext display. That she may have decided upon the accommodation she provided after consulting with Judge Kruse does not demonstrate that she was exercising a quasi-judicial function rather than implementing the requirements of the ADA pursuant to duties that had been assigned to her—particularly in light of Judge Kruse's testimony that Botta did not consult with him or inform him about Duvall's request for videotext display. In fact, some of Botta's deposition testimony strongly suggests that her decision not to provide videotext display was administrative in nature.

Q: You said that if someone came to you and requested an ASL interpreter for litigation, you would make that decision yourself.

A: Right, based on the statute.

Q: Which statute?

A: I can't cite it to you, but it's my understanding that the legislature has decided that sign-language people should be available and that there is a statute—I can't cite it to you.

Q: Do you know if that statute speaks to any disabilities other than the need for a sign-language interpreter?

A: I don't know.

Q: So based on that statute you had the authority to provide ... [a] sign-language interpreter?

A: Right.

Thus, it appears that when a statute requires, or perhaps even authorizes, the provision of a particular form of assistive device to a hearing-impaired individual, Botta has the authority to make the necessary arrangements therefor, as an administrative matter. Further, it appears that in acknowledging her authority in that regard, that Botta may have been advertent to the very statutes at issue here.¹⁴⁵ Accordingly, the type of decision-making authority Botta exercised in Duvall's *1135 case appears, at the very least, to raise an issue of material fact as to whether she was acting in an administrative rather than quasi-judicial capacity. Because the burden is on the official claiming immunity to demonstrate that public policy requires recognition of an absolute immunity, [c], we hold that Botta's deposition testimony alone precludes summary judgment in her favor.

[***Analysis of substantive allegations of violations of the ADA, the Rehabilitation Act, and the WLAD omitted here]

¹⁴⁵ Although neither the Rehabilitation Act nor Title II of the ADA, on its face, requires the provision of sign-language interpreters as an accommodation for hearing-impaired individuals, the regulations promulgated by the Attorney General under Title II list sign-language interpreters and videotext display as among the accommodations required, in appropriate circumstances, by the ADA. 28 C.F.R. § 35.104(1).

The district court's grant of summary judgment in favor of Judge Kruse and the members of the Board of County Commissioners is hereby AFFIRMED. The order of summary judgment in favor of Botta, the County of Kitsap, Razey, and Richardson is REVERSED as to all claims. The case is REMANDED to the district court for proceedings consistent with this opinion.

AFFIRMED in part, REVERSED in part, and REMANDED.

RYMER, Circuit Judge, dissenting:

Like Judge Kruse, the Court Administrator, Madelyn Botta, is sued for damages and like him, I believe she is entitled to immunity. As the majority recognizes, the judge was performing a judicial function when he declined on the first day of trial (June 21, 1995) to order videotext display for Duvall and when he denied Duvall's motion for a new trial (August 11) based on the absence of real time assistance at trial. Botta's actions were functionally no different. For essentially the same reasons that Judge Kruse is absolutely immune, the Court Administrator should be, too.

Duvall argues that Judge Kruse acted in an administrative capacity in denying Duvall's request for accommodation and that "he has no immunity to share with the remaining defendants." The majority holds otherwise with respect to the judge, and I agree. Duvall's argument that *Botta* lacks immunity stems from the same premise—that *Judge Kruse* was performing an administrative, not a judicial, function, therefore so was the Court Administrator. As we unanimously reject this premise, this should be the end of the matter.

Court clerks or administrators are entitled to absolute immunity from liability for damages "when they perform tasks that are an integral part of the judicial process." *Mullis v. United States Bankruptcy Court*, 828 F.2d 1385, 1390 (9th Cir.1987) (court clerks have absolute quasi-judicial immunity for filing decision).¹⁴⁶ *1143 Here, assuming Duvall's version is true, he approached Botta before trial for videotext assistance at trial. Botta declined to talk to Duvall because he was represented by counsel, but told him to make his request in the form of a motion to the court. Duvall does not dispute that Botta did not have authority to grant his request once litigation was underway. He in fact asked the judge presiding over his divorce for real time accommodation on the first day of trial. The judge denied the request. This was clearly a discretionary judicial decision. [***]

Neither Duvall nor the majority explains why Botta's instruction to take his request to the judge was not part of the judicial process. Nor does either explain why she should not be bound (or least not be properly guided) by the judge's decision at trial when she was later consulted by the county ADA coordinator with regard to Duvall's post-trial request for accommodation at a post-trial hearing. [***]

However you slice it, determining whether a particular hearing impaired individual needs accommodation for a court proceeding, and what kind of accommodation is reasonable, entails the power of decision. It is either a judicial function, or comparable to one. It is not

¹⁴⁶ See also *Moore v. Brewster*, 96 F.3d 1240, 1244 (9th Cir. 1996) (according immunity to clerk of the United States District Court for the Southern District of California given nature of the responsibilities); *Sharma v. Stevas*, 790 F.2d 1486 (9th Cir. 1986) (clerk of United States Supreme Court has quasi-judicial immunity); *Morrison v. Jones*, 607 F.2d 1269, 1273 (9th Cir. 1979) (court clerk's "failure ... to perform a ministerial duty [giving notice of order] which was a part of judicial process is also clothed with quasi-judicial immunity"); *Shipp v. Todd*, 568 F.2d 133, 134 (9th Cir. 1978) (recognizing quasi-judicial immunity for clerk of Montana state court from damages but not injunctive relief); *Harmon v. Superior Court*, 329 F.2d 154, 155 (9th Cir. 1964) (recognizing absolute immunity for county clerk and other judicial personnel).

administrative,¹⁴⁷ legislative, or executive. Judges may *1144 delegate some part of this function to the court administrator or clerk of court, but at the end of the day the function is, and remains, judicial.

In addition, Duvall was not without redress for he could appeal the judge's rulings. As the Supreme Court has observed, "[m]ost judicial mistakes or wrongs are open to correction through ordinary mechanisms of review, which are largely free of the harmful side-effects inevitably associated with exposing judges to personal liability." [c]. Duvall does not need, and should not be allowed, to seek damages from a court administrator for an arguably incorrect determination about his needs or the court's ability to address them. This is what appeals are for. To withhold judicial immunity from the clerk in these circumstances permits a party to play the clerk off against the judge, an unseemly as well as unnecessary distraction.

Without question, the judge is the final decision-maker with respect to proceedings in his court. RCW 2.28.010. For this reason, aside from immunity, I do not see how Duvall could be injured by anything Botta did or didn't do, or how Kitsap County, non-court personnel [***] and Richardson could have told the judge what to do. Washington judges are state actors, whose authority comes from the state not the county. Wash. Const., Art. IV, § 1; see *Keenan v. Allan*, 889 F. Supp. 1320, 1363 (E.D.Wash. 1995) (judges are officers of Washington State). As we have held in connection with a similar system elsewhere, a county cannot be liable for judicial conduct it lacks the power to control. [c]

Accordingly, I would affirm.

Note 1. Does the majority define the scope of judicial immunity properly in your view, or improperly, in distinguishing between the acts of the judge versus the administrator? Should something like a vicarious liability rule apply if, as the dissent suggests (writing with the authority of a judge), "the judge is the final decision-maker with respect to proceedings in his court"? Are judicial clerks different from administrators, if their work involves primarily research, writing and counseling the judge on the substantive matters before the judge? (*See* the footnote in the opinion at p. *1143 in which the court lists jurisdictions that do provide partial or full immunity for clerks.)

Note 2. The majority opinion writes that "[b]ecause the burden is on the official claiming immunity to demonstrate that public policy requires recognition of an absolute immunity, [c], we hold that Botta's deposition testimony alone precludes summary judgment in her favor." What is the practical effect of this statement? Can you articulate the reasons—descriptive and normative—for allocating the burden of proof in this way at this stage?

Note 3. Where do you stand on the dissent's argument that money damages are not the right remedy for an argument like this one (assuming a violation of the ADA and/or other anti-discrimination laws is proven)? The dissent argues that Duvall did have another means of redress in the form of appealing the judge's rulings. What concerns are driving the dissent's argument?

Note 4. If judges are to remain immune for decisions like the ones in *Duvall*, more training seems necessary in light of the apparent failures to understand the impact on a litigant that can be wrought by a failure to make necessary accommodations. Especially in the context of high-conflict proceedings such as dissolution, in which the parties were even instructed not to stand too close to each other, what

¹⁴⁷ "Administrative functions are actions which are significant independent of the fact that the actor is a judge, such as the hiring or firing of staff members." *Partington v. Gedan*, 961 F.2d 852, 866 (9th Cir. 1992) [c].

ought to be done? Are there reforms you can imagine, whether legal or sociocultural, to improve the environment for parties and advocates who may need accommodations in order to gain meaningful access to the legal system?

Note 5. This opinion from 2001 quotes but does not rebuke or comment on, judicial language that is plainly ignorant about and dismissive of an entire community of people living with hearing-based challenges. In fact, there is a lively discussion among academics, historians and advocates over whether deafness is misunderstood when it is cast as a disability rather than a difference signifying belonging to a subculture that operates apart from the “mainstream hearing community.” However, deaf people may still require accommodations to enable their participation in mainstream events, including legal hearings. Thus the ADA is a powerful and welcome tool for ensuring access to justice and other societal institutions and spheres. Still, it is surely mistaken, careless and lacking in empathy to state, as Judge Kruse does, “[T]hat’s the way humans happen to communicate, I guess up until a very recent time, with one another is orally.... I can only assume that if Mr. Duvall wished to have that service available he can provide that service for himself.”¹⁴⁸

Note 6. Duvall relayed that “requiring him to remove his hearing aids to use the inferior Soundmate system was equivalent to requiring a person with an artificial leg to remove the leg and use crutches.” He may have merely been trying to use an analogy that a hearing person could understand better. Does the use of this analogy, however, convey a sense of deafness as physically disabling in a way that may help a legal argument but undercut the cause of deafness as a cultural condition rather than a disability? And if the analogy does help advance Duvall’s legal argument, does it do so by relying on the pathos associated with bodies that are “not normal” thus displaying its own ableism? Or is it simply an effective way of conveying that the best way to overcome different physical challenges is not necessarily universal but must be tailored and the best person to ask is the person overcoming the challenges?

Professor Anne Bloom and the late Professor Paul Steven Miller have written that tort litigation suffers what they call “blindsight” (deliberately invoking associations with blindness so as to reclaim them):

Tort litigation’s blindsight stems from its assumption that the lives of people with disabilities are tragic. ... This perspective is blindsighted because people with disabilities do not tend to share this assessment of their lives; in their view, a life with a disability is no more or less tragic than a life without one... [T]ort litigation’s distorted perspective fosters troubling stereotypes and encourages plaintiffs with disabling injuries to view themselves in harmful ways. ... From a disability rights perspective, this extreme focus on plaintiffs’ bodies overlooks important aspects of a disabling injury... While there may be many physical issues associated with disability, the main problem that most people with disabilities face is not their bodies but social oppression... A person with a spinal injury, for example, faces less of a challenge from walking than from social discrimination and the inability to gain access to many buildings with a wheelchair... Thus, from a disability rights perspective, when a person

¹⁴⁸ (For further discussion, see e.g. <https://www.psychologytoday.com/us/blog/talking-apes/201802/is-deafness-really-disability> and Erica R. Harvey, Deafness: A Disability or a Difference (2013), 2 Health Law & Policy 42 (2008), available at: <https://digitalcommons.wcl.american.edu/cgi/viewcontent.cgi?article=1073&context=hlp>)

suffers a disabling injury, social and environmental factors play a significant role in creating the condition of being designated as disabled.

Anne Bloom & Paul Steven Miller, *Blindsight: How We See Disabilities in Tort Litigation*, 86 Wash. L. Rev. 709, 712-13, 717 (2011) They suggest that “[i]nstead of portraying plaintiffs as “tragedies,” legal actors in tort litigation could present their clients’ disabling injuries in more complex ways that better reflect people with disabilities’ actual experiences.” They recognize that compensation is important in torts cases featuring severe injuries but argue in favor of a more empowering, less tragedy-affirming perspective. One of their primary recommendations is to enable those with disabilities to play a more active and prominent role in their cases, something that we have seen Duvall was trying to do, in vain.

Check Your Understanding (4-4)

Question 1. In *Duvall v. Kitsap County*, the majority holds that Judge Kruse has absolute judicial immunity. Based on that ruling, which of the following would open Judge Kruse to liability:

- (i) Judge Kruse’s determination not to provide appropriate accommodation was based on his personal contempt toward Mr. Duvall.
- (ii) Judge Kruse’s determination not to provide appropriate accommodation was based on a privately held and biased view of the hearing impaired.
- (iii) Judge Kruse, while hosting a dinner party, negligently failed to warn his clerk that the kitchen sink was broken such that water coming out of the sink was dangerously hot. The clerk was injured while attempting to help clean up.

An interactive H5P element has been excluded from this version of the text. You can view it online here: <https://saidtorts2d.lawbooks.cali.org/?p=72#h5p-101>

2. Parental Immunity

Rousey v. Rousey, District of Columbia Court of Appeals (1987) (528 A.2d 416)

Appellee, Doris Rousey, and her eleven-year-old daughter, Cheryl Rousey, were involved in an automobile accident in the District of Columbia. Cheryl sustained injuries, and through her father, Smith Rousey, she brought suit against her mother, alleging that the accident and her injuries were a direct and proximate result of her mother’s negligence. Mrs. Rousey, who was insured by Government

Employees Insurance Company and represented by its counsel, filed a motion for summary judgment on the ground that parental immunity barred appellant from suing his wife on behalf of their unemancipated daughter. The court granted the motion, and Mr. Rousey appealed to this court.

A division of the court, recognizing that the doctrine of parental immunity had never been established as the law of the District of Columbia, refused to adopt it and held that appellant was not barred from maintaining this suit against appellee, his wife, on behalf of their unemancipated minor child. *Rousey v. Rousey*, 499 A.2d 1199 (D.C.1985). That decision was vacated when the court decided to rehear this case en banc. *Rousey v. Rousey*, 507 A.2d 1046 (D.C.1986). A majority of the court en banc now concludes, as did the division, that the parental immunity doctrine is out of date. We decline to adopt it, choosing instead to follow section 895G of the Restatement (Second) of Torts (1979), which in our view sets forth a more appropriate legal standard. We therefore reverse the trial court's order granting summary judgment to appellee.

Unlike interspousal immunity, parental immunity was unknown at common law. *417 [c] Interspousal immunity was based on the notion that husband and wife were legally one person,¹⁴⁹ whereas parent and child were never so regarded. Children, unlike wives, were entitled to own property and to enforce their own choses in action, including those in tort; likewise, they were liable as individuals for their own torts. [cc]

The notion that a parent might be immune from liability for tortious conduct toward his or her child was not recognized in the United States until 1891, when the Supreme Court of Mississippi refused to permit a suit brought by a child against her mother, alleging that the mother had falsely imprisoned the child in an insane asylum. In ordering the suit dismissed, the court said:

[S]o long as the parent is under obligation to care for, guide, and control, and the child is under reciprocal obligation to aid and comfort and obey, no such action as this can be maintained. The peace of society, and of the families composing society, and a sound public policy, designed to subserve the repose of families and the best interests

¹⁴⁹ This rationale began to be questioned after the widespread enactment of statutes known as Married Women's Acts, beginning in the mid-nineteenth century, which gave wives many of the rights that their husbands had always enjoyed. Some courts thus found it necessary to develop new theories to support the concept of interspousal immunity. The idea that most often found favor was that "personal tort actions between husband and wife would disrupt and destroy the peace and harmony of the home...." Restatement, *supra*, § 895F, comment d. Other courts, including this one, simply held that "[t]he common law rule forbid[ding] a wife to sue her husband for any tort committed against her ... [was] unaffected by the Married Women's Act." *Mountjoy v. Mountjoy*, 206 A.2d 733, 733 (D.C.) (citations omitted), *appeal denied*, 121 U.S.App.D.C. 27, 347 F.2d 811 (1965). The common law doctrine of interspousal immunity was abolished in the District of Columbia by statute in 1976. D.C.Code § 30-201 (1981) now provides in pertinent part:

The fact that a person is or was married shall not, after October 1, 1976, impair the rights and responsibilities of such person, which are hereby granted or confirmed, to ... engage ... in any civil litigation of any sort (whether in contract, tort, or otherwise) with or against anyone, *including such person's spouse*, to the same extent as an unmarried person.... [Emphasis added.]

Given this enactment, it would be anomalous indeed for this court to adopt parent-child immunity as the law of the District of Columbia when the most frequently cited rationale for that doctrine—the need to preserve domestic tranquility and family unity—has been rejected by our own legislature in abolishing interspousal immunity.

of society, forbid to the minor child a right to appear in court in the assertion of a claim to civil redress for personal injuries suffered at the hands of the parent.

Hewellette v. George, 68 Miss. 703, 711, 9 So. 885, 887 (1891). Although the court cited no authority for this proposition, courts in all but eight other states followed Mississippi's lead and adopted some form of parental immunity. [c]

Various reasons have been advanced in support of parental immunity, but the reason most frequently cited by the courts has been the need to preserve domestic tranquility and family unity. [cc] Many courts have relied heavily upon the analogy between husband and wife, despite the obvious differences between the husband-wife relationship and the parent-child relationship. Because at common law husband and wife were treated as one person, a wife generally could not sue her husband. [c] Children, however, were never treated as mere extensions of their parents; they could even sue their parents in tort to protect their *418 property rights. [c] The situation with respect to personal torts is somewhat less clear, since there are very few reported cases, but there is little reason to doubt that the common law would permit actions for personal torts as well, subject only to the parent's right to enforce reasonable discipline against the child. [c] Thus we find the analogy to interspousal immunity to be a faulty one, providing no real justification for immunity between parent and child. Moreover, the courts that have adopted parental immunity have never adequately explained why the immunity applies only to suits in tort and not to suits involving property or contract rights. An action to enforce property or contract rights is surely no less adversarial than an action in tort, and in theory, at least, it would present the same threat to family harmony.

Of course, the analogy to interspousal immunity and the concern with domestic tranquility have not been the sole justifications for parental immunity. The courts have also expressed concern that parental discipline and control might be compromised if children were permitted to sue their parents. [cc] Others believed that an uncompensated tort contributed to peace in the family and respect for the parent. [c] The absurdity of this reasoning, however, becomes plain when the case involves rape, *Roller v. Roller*, 37 Wash. 242, 79 P. 788 (1905), or a brutal beating, *Cook v. Cook*, 232 Mo.App. 994, 124 S.W.2d 675 (1939); *McKelvey v. McKelvey*, 111 Tenn. 388, 77 S.W. 664 (1903), or when the parent-child relationship has been terminated by death before the suit was filed. *Lasecki v. Kabara*, 235 Wis. 645, 294 N.W. 33 (1940).

Persistent criticism of the doctrine of parental immunity eventually led to its erosion through the creation of various exceptions to it.¹⁵⁰ One court asserted that parent-child immunity "should not be tolerated at all except for very strong reasons; and it should never be extended beyond the bounds compelled by those reasons." [c] Other critics of the doctrine went even further, arguing for its complete abandonment. See, e.g., McCurdy, *Torts between Parent and Child*, 5 VILL.L.REV. 521, 529 (1960); McCurdy, *Torts between Persons in Domestic Relation*, 43 HARV.L.REV. 1030, 1079–1080 (1930); [cc]

The courts of the District of Columbia were not faced with the issue until 1948, in a case in which a thirteen-year-old boy brought suit against his mother for injuries he suffered in an automobile accident.

¹⁵⁰ See, e.g., *Dzenutis v. Dzenutis*, 200 Conn. 290, 512 A.2d 130 (1986) (no immunity when child's injury arose out of a business activity conducted by the parent away from the home); *Hale v. Hale*, 312 Ky. 867, 230 S.W.2d 610 (1950) (no immunity when death of either parent or child terminates the parental relationship); *Dunlap v. Dunlap*, 84 N.H. 352, 150 A. 905 (1930) (no immunity for intentional or reckless infliction of bodily harm).

The accident occurred in Maryland, however, and hence the only question before the court was whether the son had a right to bring suit under Maryland law. After stating that the issue had not been decided in the District of Columbia and that it was “neither necessary nor proper ... to analyze the authorities, weigh the problem and announce a rule,” the court concluded that decisions of the Maryland Court of Appeals “on kindred questions clearly indicate its accord with the overwhelmingly prevalent rule that public policy forbids such suits.” *Villaret v. Villaret*, 83 U.S.App.D.C. 311, 312, 169 F.2d 677, 678 (1948). [***]

Although the “overwhelming weight of authority” did at one time favor parental immunity, the doctrine began to lose judicial support after a 1963 Wisconsin decision which abolished it entirely except when the allegedly tortious act involved “an exercise of parental authority ... [or] ordinary parental discretion with respect to the provision of food, clothing, housing, medical and dental services, and other care.” *Goller v. White*, 20 Wis.2d 402, 413, 122 N.W.2d 193, 198 (1963). In 1977 the American Law Institute completely rejected general tort immunity between parent and child when it published section 895G of the Restatement (Second) of Torts. That section states:

- (1) A parent or child is not immune from tort liability to the other solely by reason of that relationship.
- (2) Repudiation of general tort immunity does not establish liability for an act or omission that, because of the parent-child relationship, is otherwise privileged or is not tortious.

Many states have since followed the lead of *Goller v. White* and the Restatement, so that a substantial majority of states have now abandoned the doctrine in whole or in part. To date eleven states have abrogated it entirely or declined to adopt it; [fn] eleven have abrogated it in automobile negligence cases; [fn] five have abrogated it in automobile negligence cases in which the parent has liability insurance; [fn] and seven have abrogated it except in cases in which the parent’s alleged tortious act involves an exercise of parental authority over the child, or ordinary parental discretion with *420 respect to such matters as food, care, and education. [fn]

This trend toward abrogation is attributable, in large part, to the prevalence of liability insurance. [cc] The availability of insurance relieves the parents of direct financial responsibility for injuries sustained by their children, and thus substantially reduces the possibility that an action for damages will disrupt domestic tranquility or family unity. As the Supreme Judicial Court of Massachusetts wrote in *Sorensen*:

When insurance is involved, the action between parent and child is not truly adversary; both parties seek recovery from the insurance carrier to create a fund for the child’s medical care and support without depleting the family’s other assets. Far from being a potential source of disharmony, the action is more likely to preserve the family unit in pursuit of a common goal—the easing of family financial difficulties stemming from the child’s injuries. [*Sorensen v. Sorensen*, 369 Mass. 350, 362 (1975)] [cc]

Although there is a possibility that parent and child may conspire to defraud the insurance carrier or that the parent may fail to cooperate with the carrier as required under the insurance contract, [c] that

possibility exists to a certain extent in every case;¹⁵¹ it hardly justifies a “blanket denial of recovery for all minors.” *Sorensen, supra*, 369 Mass. at 363, 339 N.E.2d at 915; [cc].

We constantly depend on efficient investigations and on juries and trial judges to sift evidence in order to determine the facts and arrive at proper verdicts. As part of the fact-finding process, these triers of fact must “distinguish the frivolous from the substantial and the fraudulent from the meritorious.” ... Experience has shown that the courts are quite adequate for the task. *Id.* at 914-915.

Because there is no controlling precedent on the subject of parental immunity, [fn] we need not overrule any prior decisions. Rather, we simply decline to adopt the doctrine of parental immunity as the law of the District of Columbia. We acknowledge that doctrine for what it is: an outdated notion based on faulty premises. We see it as a vestige of an era in which children were without legal protection from the wrongs of their parents, and married women were without legal rights, subordinate to their husbands, all in the name of family harmony. More specifically, we are persuaded that section 895G of the Restatement *421 (Second) of Torts, *SUPRA*, IS JURISPRUDENTIALLY SOUND, AND WE ACCEPT IT AS A CORRECT STATEMENT OF THE LAW APPLICABLE TO CASES SUCH AS THIS.¹⁵²

Thus we reject appellee’s argument that an unemancipated minor child should be barred, in the interest of family unity, from suing his or her parent for negligence. When a wrong has been committed between parent and child, “the harm to the family relationship has already occurred; and to prohibit reparations can hardly aid in restoring harmony.” [c]. We see no reason, moreover, to limit our holding to cases in which the parent-defendant has liability insurance, as some courts have done. [fn] There can be no justification for fashioning different rules of law for the insured and the uninsured. [c] The availability of insurance funds to satisfy a judgment should not determine the viability of an action by a child against a parent (or vice versa), nor should the judgment necessarily be limited to the amount of the insurance policy.

The order granting appellee’s motion for summary judgment is reversed. This case is remanded to the Superior Court for further proceedings consistent with this opinion.

Reversed and remanded.

NEBEKER, Associate Judge, dissenting:

The majority gives all the appearances of being quite unsure about its new holding. In the face of a division opinion limiting suits by issue to automobile accidents covered by insurance, *Rousey v. Rousey*, 499 A.2d 1199 (D.C.1985), the majority now retreats from that unusual view to general amenability to suits by offspring. They then hedge, as does the RESTATEMENT, by hinting at

¹⁵¹ We think it significant that such a possibility of conspiracy between husband and wife did not dissuade the Council of the District of Columbia from abolishing interspousal immunity more than ten years ago. See note 4 [8], *supra*.

¹⁵² We emphasize that we are accepting section 895G in its entirety. We are aware that subsection (2) recognizes, or at least assumes, that certain acts or omissions may be privileged or non-tortious by reason of the parent-child relationship. We need not attempt in this case to identify the types of conduct that may be privileged or non-tortious under subsection (2); that will have to be done in the future on a case-by-case basis. As the Restatement tells us, “[t]hese problems are comparatively new to the courts as a result of the recent abrogation of immunity, and the courts have not yet worked out a full analysis of the proper legal treatment.” RESTATEMENT, *supra*, § 895G, comment k. We defer that “full analysis” until we are faced with a case that requires it.

unknown exceptions where in the future we may conclude the case involves the type of conduct which may “on a case-by-case basis” be identified as “privileged or non-tortious.” [c]. The court thus behaves like an ill-advised legislature, acting broadly while it continues to study the need to make exceptions to the broad new enactment. This, in my view, is a poor way to take such a serious step. The hedging also implicitly recognizes that this question is for the legislature. Moreover, the majority chooses to ignore what to me are obviously damaging consequence to family structure and a moral imperative that compel the opposite conclusion.

In declining to adopt parental immunity, the majority disparages the wisdom of the past which championed the family unit, as if a contrary modern view is obviously superior. The majority finds solace in the fact that at common law there was no parental immunity and that children could enforce their own contract and property rights and bring their own action in tort. *Ante* at 416–417. This selective recourse to history ignores a body of law from the ecclesiastical courts where, in their domain, such suits were unthinkable. *See McCurdy, Torts Between Persons in Domestic Relation*, 43 HARV.L.REV. 1030, 1060 n. 141 (1930). The majority criticizes an analogy to spousal immunity and asserts that the rationales which support it are not applicable to parental immunity. [c] I agree with this point. Because the common law view of the husband-wife relationship differed from that of the parent-child, any justification by way of analogy is tenuous. Accepting this, however, I find somewhat perplexing the majority’s process of rejecting parental immunity *422 by comparing it to the statutory abolition of spousal immunity in the District of Columbia in 1976.

But enough of their fallacious reasoning! The main concern is misguided policy. I view the fact that parental immunity did not exist at common law to be irrelevant because “no American child tortiously injured by his parents had ever sought to recover damages until late in the nineteenth century.” Hollister, *Parent-Child Immunity: A Doctrine in Search of Justification*, 50 FORDHAM L.REV. 489, 498 (1981–1982). It seems that prior to 1891, our social and legal evolution had not “progressed” to the point that a child, or more accurately one in concert with him, could or would consider suing a parent in tort. The reason may have been that our society tolerated “almost unbridled parental authority,” [c] or that prior to our saturation with liability insurance, there was less incentive to sue. Of course, collusive actions were not permitted. [c] In any event, it appears the legal profession and a family oriented society simply deemed it unthinkable for a child to bring a tort action against his parent. Thus, the testing of liability was simply not contemplated. Accordingly, a doctrine of immunity would have been superfluous.

In 1891, when a tort claim was eventually brought by a daughter against her mother, the Supreme Court of Mississippi promulgated the doctrine of parental immunity. *Hewellette v. George*, 68 Miss. 703, 9 So. 885 (1891). Although it has been attacked as an “exception to the general rule of liability for negligently caused injury,” Hollister, *supra*, 50 FORDHAM L.REV. at 504, parental immunity is more appropriately considered a judicial response to the latter-day attempt to pit child against parent and other family members. I see rejection of this immunity as part of the pandemic course to expand compensation for injury to yet another outer limit.

The likelihood of harm to the family structure if parental immunity is rejected has summarily been dismissed by the majority—in a manner similar to the decisions from other jurisdictions which have undertaken to reject this immunity, *see Petersen v. City and County of Honolulu*, 51 Hawaii 484, —, 462 P.2d 1007, 1009 (1969). Moreover, I submit that pointing to the familial discord which may also result from intentional, wanton or grossly negligent conduct is misdirected. The case before us is

not one of an intentional or criminally reckless nature. Rather, it stems from an activity which today is essential to the functioning of a household—the operation of the family automobile. Anyone who has reared children today can attest to the near indispensability of the family car or cars.

I note that the majority seems to hope that family discord from offspring suits will be avoided because insurance will eliminate true adversity. It will not; and it will foster collusion. But liability insurance should not serve as the basis for rejecting the doctrine of parental immunity in any event. The majority notes the prevalence of liability insurance as its primary justification for creating new legal rights and duties within the family. I believe it imprudent public policy to sanction a new area of tort liability on the grounds that “[t]he availability of insurance relieves the parents of direct financial responsibility for injuries sustained by their children...” [c]

The theory of insurance is that it is supposed to give financial protection against the occurrence of a known risk. Once a type of insurance exists, it is not supposed to encourage the creation of new actions at law. The rationale in this case says, in essence, that because liability insurance exists, this jurisdiction will now create a new *423 class of tort claimants who are eligible to recover because it is hoped most claims will be covered. It would be just as well for the majority to justify its new rule on the hope that suits will not be brought absent insurance coverage.

The whole principle of insurance becomes distorted when the presence of insurance encourages new kinds of liability. As additional types of liability are permitted by the court, the insurance companies must either raise policy premiums or exclude coverage as to that particular risk. This latter approach, which is both logical and lawful, if chosen, would eliminate the very reason for the court’s holding in the first place. In the meantime, we encourage collusive suits where no adversity exists,¹⁵³ or pit family members against each other in true adversity.

Permit me to ask some unanswered questions where insurance is not a part of the scheme. Does our new rule permit actions for negligent failure to seek medical treatment or diagnosis, or to provide special education? Moreover, with abortions being lawful, may a child now sue a parent for wrongful birth if he is born with a foreseeable defect? Through a “case-by-case” process, we will find out sooner or later.

The rearing of a child is a unique and delicate responsibility. The teaching, nurturing and disciplining functions performed by every parent vary. They are a function of the social, economic and religious circumstances in every household. To subject a parent to liability based upon near indefinable standards will, I fear, have a detrimental impact on the family unit. The threat of a tort suit could shackle a parent and prevent the flexibility needed to exercise parental control. As a child progresses through the more intractable stages of adolescence, a parent’s fear of being sued must clearly undermine the exercise of parental authority, and thus the family structure. These concerns loom larger as our society grows more litigious.

I fear the majority has thought precious little of the consequences. They would no doubt justify their holding on the ground that they simply compensate injury by making the one at fault pay. But how will

¹⁵³ “Because a child has only limited knowledge and ability in legal matters, the decision to sue is usually made by his parents.” Hollister, *supra*, 50 FORDHAM L. REV. at 500. See *Streenz v. Streenz*, 106 Ariz. 86, 88, 471 P.2d 282, 284 (1970) (“Where [automobile liability] insurance exists ... in reality the sought after litigation is not between child and parent but between child and parent's insurance carrier.”); *Sorensen v. Sorensen*, 369 Mass. 350, 362, 339 N.E.2d 907, 914 (1975) (“When insurance is involved, the action between parent and child is not truly adversary....”).

this really work? In a family structure it is usual to have both parents share in the rearing function. If one parent causes an injury and is at fault, does the other parent owe a duty to the injured child to seek recovery? I suppose so, though we do not say so. If that parent, out of concern for other children or simple devotion to the other parent, or negligence, fails to pursue recovery until a case cannot be proved, what of that parent's liability? Can an older child, upon reaching majority, sue within the limitations period and deprive younger siblings of the family income or assets? I am sure the response is—"we will decide those cases later 'on a case-by-case basis.'" Such tinkering with the already fragile family structure by judges with no formal training or experience in such matters is ill-advised. It tears at family unity. With or without liability insurance, it unavoidably pits one child against any others for limited family resources and one parent against the other. At a time when families find it hard or impossible to exist without both parents working, we now create a competition for income within the family. And insurance is not the palliative. When a claim is made, the policy can be canceled or the premium increased. In automobile accidents this can be devastating to the family.

Moreover, I anticipate that pressure to sue one or both parents will strain the moral fiber which holds families together. Well-structured families will probably ignore our permissive holding. Those not so stable will find little solace in their lucre when they discover the inevitable decay in *424 their moral fiber. Should one of a number of children get a greater share of family assets or in some other way burden the others because one or both parents caused an injury? What "next friend" will make that choice and at what price within the family? I cringe at this holding and what it can mean to our most precious national resource—the family. It foists upon parents, or other family members such as grandparents, aunts and uncles, a choice that can only be described as damnable. What we have wrought I am not sure, but of this I am certain—it is an intruder into any family circle as much as any burglar or disease. And what is worse, it rides a steed called law.

I opt for immunity and family unity; so I dissent.

BELSON, Associate Judge, with whom Chief Judge PRYOR joins, dissenting:

I write separately because I prefer to state narrowly the reason I think this court should not abrogate the doctrine of parental immunity.[***]

[T]he United States Court of Appeals, by unmistakable implication, accepted the District Court's conclusion that minor children may not sue their parents in tort. *Perchell v. District of Columbia*, 144 U.S.App.D.C. 122, 123–24, (1971) The court expressly modified "[t]he doctrine of parental immunity as applied in *Dennis v. Walker*" to allow the defendant to sue for contribution from the minor plaintiffs' father, despite the fact that parental immunity barred the minor plaintiffs themselves from suing him. *Id.* at 124, 444 F.2d at 999. By so modifying the doctrine of parental immunity, the court implicitly acknowledged its existence in this jurisdiction. Although not binding upon this court, [c] *Perchell* reflects what the state of the law regarding parental immunity has been in the District of Columbia.

Given this jurisdiction's consistent adherence, until now, to the doctrine of parental immunity, the majority decision's departure from the doctrine reflects a determination of public policy better suited to consideration by the District of Columbia Council. As an elected legislative body, the Council is in a better position to weigh competing policy considerations such as the potential for collusive lawsuits, divisiveness in family *425 structures, and the need to compensate tort victims.

Note 1. What is the holding in this case? What is its practical effect? What rationales does it cite in support of its ruling? What role does liability insurance play in its view of the issue?

Note 2. What do you suppose is the significance of the court's stating that it is *not overruling* prior case law but simply choosing not to adopt parental immunity? How is the majority's view of this issue different from the dissenting opinions on that point?

Note 3. What does the court mean by "general tort immunity between parent and child" when it writes the following: "In 1977 the American Law Institute completely rejected general tort immunity between parent and child when it published section 895G of the Restatement (Second) of Torts"?

Note 4. The most common justifications for adopting parental immunity have included (1) maintaining family harmony; (2) preserving parental authority over the discipline, supervision, and care of children; (3) preventing fraud and collusion between family members; and (4) protecting family finances and resources from depletion in favor of one child at the expense of others. In many jurisdictions, if any parental immunity has been retained, it is limited to the kinds of discretion associated directly with parental choices (e.g. setting bedtimes, making nutritional choices, selecting medical treatment) rather than with "garden-variety" negligence or ordinary, non-parental acts of discipline and supervision. Does this line-drawing seem to you to resolve the issue well? Why or why not?

Note 5. What concerns seem most to animate the dissent?

Note 6. Is the dissent correct that the majority is "creating new legal rights and duties" within the family, and in its assertion that it does so on the basis of the availability of liability insurance? The dissent writes: "The majority notes the prevalence of liability insurance as its primary justification for creating new legal rights and duties within the family. I believe it imprudent public policy to sanction a new area of tort liability on the grounds that '[t]he availability of insurance relieves the parents of direct financial responsibility for injuries sustained by their children....' [c] 'Once a type of insurance exists, it is not supposed to encourage the creation of new actions at law.'"

Note 7. The second, shorter dissent makes two main points. What are they? Can you see how the second bolsters the first?

Immunity and Allocation of Liability

One challenge associated with identifying immunities in a given case is the effect they may have when multiple parties are at fault and one of them is protected by an immunity. This next case illustrates the challenging policy issues at the intersection of immunity, comparative fault and joint and several liability.

Smelser v. Paul, Supreme Court of Washington (2017) (188 Wash.2d 648)

*649 This case concerns the intersection of the doctrine of parental immunity with the system of proportionate liability under chapter 4.22 RCW. Two-year-old *650 Derrick Smelser was run over

while playing in his yard by a car driven by the defendant, Jeanne Paul. At trial, Paul was allowed to assert an affirmative defense that the child's father was partially at fault based on negligent supervision of the child. Instructed under RCW 4.22.070, the jury determined the father was 50 percent at fault. However, the trial court refused to enter judgment against the father based on the parental immunity doctrine. The result was that the child's recovery against the driver was reduced by 50 percent. The Court of Appeals affirmed. *Smelser v. Paul*, noted at 193 Wash.App. 1014, 2016 WL 1306678, review granted, 186 Wash.2d 1002, 380 P.3d 453 (2016). We reverse and hold that under chapter 4.22 RCW and our case law, no tort or fault exists based on the claim of negligent supervision by a parent.

When he was two years old, Derrick¹⁵⁴ was playing in his father, Ronald Smelser's, driveway. Respondent Paul, the father's then girlfriend, had been visiting and had parked her truck in the driveway. As Paul started to drive away, she hit Derrick, who "was pulled under the vehicle and dragged for a distance," and suffered severe injuries. Clerk's Papers (CP) at 300. [Remaining references to the record omitted] Derrick's father was home at the time but did not witness the accident. Derrick's five-year-old brother did witness the accident, and when the father heard Derrick's brother, Dillon, screaming, he looked in that direction and saw Derrick under Paul's truck.

This lawsuit was brought on behalf of Derrick against Paul based on negligence. Paul admitted the basic facts of the accident, but asserted as an affirmative defense that Derrick's father (who was not named as a defendant in the original complaint) was either partially or entirely responsible for the injuries based on a theory of negligent supervision. Derrick moved for summary judgment, arguing that *651 no apportionment of fault to the father was allowable as a matter of law. The court denied summary judgment. Derrick thereafter amended his complaint to include the father as a defendant. The amended complaint did not allege that the father was negligent or otherwise at fault in any way, but stated only that "Defendant Paul also contends that Defendant Ronald Smelser was concurrently negligent and/or engaged in willful misconduct which was a proximate cause of Plaintiffs' injuries." The father never appeared as a party in the suit, and the court entered an order of default against him.

The case proceeded to a jury trial. Although the father had never appeared as a party, he was called as a witness. Derrick's theory of the case was that Paul was the only one who was negligent, that her negligence was the sole proximate cause of Derrick's injuries, and that the jury was instructed that Derrick had the initial burden of proving that Paul was negligent and had caused his injuries. The jury was also instructed to then consider whether Paul had met her burden of proving, as an affirmative defense, that the father was also negligent. The jury was permitted to apportion fault to the father only if Paul met her burden of proof. The jury found that both Paul and the father were negligent and that both proximately caused Derrick's injuries. On a special verdict form, the jury attributed 50 percent of the damages to Paul and 50 percent to the father. Paul proposed the court enter a judgment against her only for the 50 percent of damages apportioned to her by the jury. Derrick objected, proposing that "a 'joint and several' Judgment be entered against both Jeanne Paul and Ronald Smelser for the entire amount of Derrick's damages." Paul, however, argued that a judgment could not be entered against the father due to parental immunity, and noted that joint and several liability is allowed only where there are two or more "defendants against whom judgment is entered." RCW 4.22.070(1)(b).

*652 The court entered judgment as proposed by Paul for 50 percent of the damages found by the jury. It did not enter any judgment against the father. The Court of Appeals affirmed. We granted review [to

¹⁵⁴ We refer to Derrick by his first name for clarity.

determine] ... [w] hether, consistent with the parental immunity doctrine, a parent can be assigned fault under chapter 4.22 RCW based on negligent supervision. ... This case requires us to consider the proportionate liability scheme in chapter 4.22 RCW in light of the common law doctrine of parental immunity. Chapter 4.22 RCW was enacted in 1986 and, in general terms, was intended to modify certain principles of tort law. Under specific situations, the statute established a system of proportionate fault, modifying the rule of joint and several liability. In situations involving a fault-free plaintiff, joint and several liability remains as to persons or entities against whom judgment is entered. The centerpiece of chapter 4.22 RCW is RCW 4.22.070. RCW 4.22.070(1) provides:

In all actions involving fault of more than one entity, the trier of fact shall determine the percentage of the total fault which is attributable to every entity which caused the claimant's damages except entities immune from liability to the claimant under Title 51 RCW. The sum of the percentages of the total fault attributed to at-fault entities shall equal one hundred percent. *The entities whose fault shall be determined include* the claimant or person suffering personal injury or incurring property damage, defendants, third-party defendants, entities released by the claimant, entities with any other individual defense against the claimant, and *entities immune from liability to the claimant*, but shall not include those entities immune from liability to the claimant under Title 51 RCW. Judgment shall be entered against each defendant except those who have been released by the claimant or are immune from liability to *653 the claimant or have prevailed on any other individual defense against the claimant in an amount which represents that party's proportionate share of the claimant's total damages. The liability of each defendant shall be several only and shall not be joint except:

....

(b) If the trier of fact determines that the claimant or party suffering bodily injury or incurring property damages was not at fault, the defendants against whom judgment is entered shall be jointly and severally liable for the sum of their proportionate shares of the claimants [claimant's] total damages.

(Second alteration in original) (emphasis added). Under RCW 4.22.070, the foundation of fault apportionment is that all tortfeasors responsible to the injured plaintiff are identified and a percentage of fault is assigned among them. Relying on the clause "entities immune from liability to the claimant," the lower courts allowed the jury to apportion fault to the father based on a claim of negligent supervision.

Before applying RCW 4.22.070, a preliminary issue that must be resolved is whether a tort duty exists from which fault can be found for negligent parenting.¹⁵⁵ The trial court and Court of Appeals failed

¹⁵⁵ RCW 4.22.015 defines "fault" as "acts or omissions, including misuse of a product, that are in any measure negligent or reckless toward the person or property of the actor or others, or that subject a person to strict tort liability or liability on a product liability claim. The term also includes breach of warranty, unreasonable assumption of risk, and unreasonable failure to avoid an injury or to mitigate damages. Legal requirements of causal relation apply both to fault as the basis for liability and to contributory fault. "A comparison of fault for any purpose under RCW 4.22.005 through 4.22.060 shall involve consideration of both the nature of the conduct of the parties to the action and the extent of the causal relation between such conduct and the damages."

to first determine whether a parent can be liable in tort for his or her child's injuries based on a theory of negligent supervision. While cases have described the principle as a form of "parental immunity," what the cases establish is that no tort liability *654 or tort duty is actionable against a parent for negligent supervision. Simply stated, it is not a tort to be a bad, or even neglectful, parent.

We comprehensively discussed the cases establishing this rule in *Zellmer v. Zellmer*, 164 Wash.2d 147, 188 P.3d 497 (2008). *Zellmer* involved a wrongful death claim brought based on the drowning death of a child while under the stepfather's care. The suit alleged negligence and negligent supervision claims. We were urged to abolish our long standing parental immunity doctrine. We rejected that argument and held the claim was barred. Important to the analysis and conclusion in *Zellmer* is the analysis of our case law and the principles we have established.

We reasoned that:

this court has consistently held a parent is *not liable* for ordinary negligence in the performance of parental responsibilities. *Jenkins [v. Snohomish County Pub. Util. Dist. No. 1]*, 105 Wn.2d 99 [, 713 P.2d 79 (1986)] (disallowing contribution claim where parents allowed child to wander free in neighborhood; child electrocuted at utility power station); *Talarico v. Foremost Ins. Co.*, 105 Wn.2d 114, 712 P.2d 294 (1986) (disallowing negligent supervision claim where parent started backyard fire then left three-year-old son unattended, resulting in severe burns); *Baughn v. Honda Motor Co.*, 105 Wn.2d 118, 119, 712 P.2d 293 (1986) (disallowing contribution claim where parents allowed sight-impaired child to ride motorbike, resulting in fatal crash); *Stevens v. Murphy*, 69 Wn.2d 939, 421 P.2d 668 (1966) (disallowing suit against divorced parent who negligently injured children while transporting them home from a scheduled visitation), [c]; *De Lay v. De Lay*, 54 Wn.2d 63, 337 P.2d 1057 (1959) (disallowing negligence action against parent who instructed son to siphon gas, resulting in bum injuries); *Cox v. Hugo*, 52 Wn.2d 815, 329 P.2d 467 (1958) (disallowing contribution claim against parent who failed to prevent child from wandering into neighbor's yard where she was burned by trash fire). [c].

*655 *Zellmer* went on to recognize when this principle applies:

There now appears to be nearly universal consensus that children may sue their parents for personal injuries caused by intentionally wrongful conduct. However, the overwhelming majority of jurisdictions hold parents are not liable for negligent supervision of their child, whether stated in terms of a limited parental immunity (among jurisdictions that have partially abrogated the parental immunity doctrine), parental privilege (among those that either abolished the immunity doctrine outright or declined to adopt it in the first instance), or lack of an actionable parental duty to supervise. ... [T]he primary objective of the modern parental immunity doctrine is to avoid undue judicial interference with the exercise of parental discipline and parental discretion. This rationale remains as vital today as it was in 1986. Parents have a right to raise their children without undue state interference. ... *Zellmer* equated the doctrine to other areas of the law where no tort action exists. [***]

What our cases establish is that no tort claim exists based on negligent parental supervision. Where no tort exists, no legal duty can be breached and no fault attributed or apportioned under RCW 4.22.070(1).

Though parental negligence is denominated an “immunity,” we have emphasized that it is similar to how courts characterize discretionary governmental decision-making under the doctrine of “discretionary immunity.” *Zellmer*, 164 Wash.2d at 159-60, 188 P.3d 497 (recognizing that “[t]he parental immunity doctrine is similar to the ‘discretionary functions’ exception).

[In a prior case, we] reasoned:

Practically all jurisdictions that have broken varying amounts of ground in the abdication of governmental immunity from tort liability have judicially, if not statutorily, recognized that the legislative, judicial, and purely executive processes of government, including as well the essential quasi-legislative and quasi-judicial or discretionary acts and decisions within the framework of such processes, cannot and should not, from the standpoint of public policy and the maintenance of the integrity of our system of government, be characterized as tortious however unwise, unpopular, mistaken, or neglectful a particular decision or act might be.

Evangelical United, 67 Wash.2d at 253, 407 P.2d 440 (citations omitted). The direct link between such immunity and parental immunity recognized in *Zellmer* makes clear that just as it is not a tort for government to govern, it is not a tort for parents to parent. Bad parenting cannot be subject to “judicial second-guessing ... through the medium of a tort action.” *Zellmer*, 164 Wash.2d at 160, 188 P.3d 497.

...

Since 1896, Washington has recognized that the negligence of a parent cannot be imputed on a child. *Roth*, 13 Wash. 525, 43 P. 641. The interpretation of RCW 4.22.070 we adopt today ensures that RCW 4.22.020 and our common law *659 principles are not violated—a parent cannot be an at-fault party based on negligent supervision, thus, their negligent actions cannot be imputed on their child.

Under chapter 4.22 RCW, a determination of fault must precede any analysis of immunity; a parent is not liable for a child’s injuries based on a theory of negligent supervision. Our cases consistently recognize no tort action exists as a matter of law. While we call this “immunity,” it is akin to discretionary governmental immunity, judicial and quasi-judicial immunity, and similar doctrines establishing that the conduct in question is simply not tortious. Thus, there is no fault to be apportioned under RCW 4.22.070.

We reverse and remand to the trial court with instructions to enter judgment against Paul for the entire amount of Derrick’s damages found by the jury.

WE CONCUR: Owens, J.; Stephens, J.; Wiggins, J.; Gordon McCloud, J.

YU, J. (dissenting)

An innocent child is badly injured through no fault of his own. His injuries were caused by the combined fault of two different people. One of those people is immune from liability to the child. Thus, who should bear the financial consequences of that person’s immunity? Should the child be forced to bear the consequences and recover the damages caused only by the nonimmune person’s fault? Or should the nonimmune person be forced to bear the consequences and pay the child’s full damages, including those caused by the immune person’s fault?

The majority adopts the latter approach, and if we were considering this question in the first instance as a matter of policy, I would too. Unfortunately, it is not our decision in the first instance, and we cannot decide it as a matter of policy. The legislature has clearly determined that the plaintiff (in this case, the child) must bear the financial consequences where fault is apportioned to an immune entity *660 pursuant to RCW 4.22.070. I therefore respectfully dissent.

As the majority rightly notes, we have previously held that a parent cannot be liable in tort for injuries to his or her child if those injuries were caused by negligent parenting. *Zellmer v. Zellmer*, 164 Wash.2d 147, 155, 188 P.3d 497 (2008). But unlike a direct claim by a child or a contribution claim by a third party, allocating fault to an immune parent does not render the parent liable. In fact, RCW 4.22.070(1) expressly *forbids* entering judgment against an immune entity. The soundness of the parental immunity doctrine is not at issue in this case.

Rather, the actual issue presented is whether Jeanne Paul was properly allowed to raise an affirmative defense that pointed to another entity (who happened to be an immune parent) whose *factual* fault limited Paul's liability to the damages actually caused by her own negligence. [...]

I agree with the majority as a matter of policy, but I cannot agree with it as a matter of law. I therefore respectfully dissent.

Note 1. The court states that “the primary objective of the modern parental immunity doctrine is to avoid undue judicial interference with the exercise of parental discipline and parental discretion.” On these facts, is the conduct of the parent an “exercise of parental discipline and discretion”? Why or why not?

Note 2. Can you articulate what this phrase means: “Washington has recognized that the negligence of a parent cannot be imputed on a child”? What effect does it have in this case?

Note 3. This case provides an example of at least three conflicting purposes: protecting parents from immunity, compensating victims for injurious harm they suffer, and allocating fault precisely and fairly in the realm of comparative fault. Does the court strike the right balance, normatively, in your view? Do you see alternatives? Would these alternatives consist of acts by the legislature, decisions by courts, or some other alternative?

Note 4. What do you make of the dissent's last line? What sort of argument is Justice Yu making?

Note 5. Which theories of justice, or which of tort law's purposes, seem most to be driving this decision?

3. Governmental Immunity

At common law, governments enjoyed sovereign immunity from tort liability, based on the idea of the king's divinity (per the Latin maxim, *rex non potest peccare* or the king is incapable of sinning/doing wrong). However, the United States federal government, as well as states and tribal government, have all chosen to limit or waive this immunity in some way (through the state constitution and/or statute). These states tend to retain immunity with respect to core governmental functions, however. Judges cannot be sued over their judicial opinions and legislators cannot be sued over the votes they cast or

the legislative decisions they make. There are two kinds of immunity: **absolute immunity** and **qualified immunity**. You can think of the retention of immunity in certain areas as absolute. When the actions are critically important to government, we protect them from liability at all costs, no matter how negligent or malicious the acts may be. This immunity reflects that solutions other than tort law exist to redress such conduct, such as voting people out of office, demoting or firing them where possible, or, in earlier days perhaps, grislier political “solutions” such as outright coup d’état. **Qualified immunity** exists pursuant to case law or in connection with a statutory waiver of immunity or creation of liability. It tends to be heavily fact specific, and the defendant’s conduct can matter a great deal here, by contrast with the domain of absolute liability, in which the breadth or nature of the immunity shields the conduct itself from scrutiny.

The scope of governmental immunity is usually tied to the governmental function. For instance, the government is immune from suit against a United States postal worker with respect to their mail delivery (no negligence claims for mis-delivered mail, for instance, no matter how badly bungled the duty might be) but not for their vehicular accidents. Indeed, Congress passed the **Federal Torts Claims Act (“FTCA”)** to waive the federal government’s immunity in part to clarify this bifurcation of legal treatment pertaining to postal delivery, as the Supreme Court stated in holding that a woman injured by a negligently left stack of mail *could* recover:

[O]ne of the FTCA’s purposes was to waive the Government’s immunity from liability for injuries resulting from auto accidents involving postal trucks delivering—and thus “transmitting”—the mail. Nothing in the statutory text supports a distinction between negligent driving, which the Government claims relates only circumstantially to the mail, and Dolan’s accident, which was caused by the mail itself. In both cases the postal employee acts negligently while transmitting mail. In addition, focusing on whether the mail itself caused the injury would yield anomalies, perhaps making liability turn on, *e.g.*, whether a mail sack was empty or full. It is more likely that Congress intended to retain immunity only for injuries arising because mail either fails to arrive or arrives late, in damaged condition, or at the wrong address, since such harms are primarily identified with the Postal Service’s function of transporting mail. The Government claims that, given the Postal Service’s vast operations, Congress must have intended to insulate delivery-related torts from liability, but § 2680(b)’s specificity indicates otherwise. Had Congress intended to preserve immunity for all delivery-related torts, it could have used sweeping language similar to that used in other FTCA exceptions, *e.g.*, § 2680(i). Furthermore, losses of the type for which immunity is retained under § 2680(b) are at least to some degree avoidable or compensable through postal registration and insurance. The Government raises the specter of frivolous slip-and-fall claims inundating the Postal Service, but that is a risk shared by any business making home deliveries. *Dolan v. U.S. Postal Serv.*, 546 U.S. 481, 482, 126 S. Ct. 1252, 1254 (2006)

Dolan treats the government’s delivery of the mail (i) as a governmental service with respect to the *mail*, and (ii) as “any business making home deliveries” with respect to the mail’s *home delivery*. *Dolan*’s reasoning reflects that governmental immunity drops away when the government’s conduct is not in some way special to the role of a governmental actor. Relatedly, many disputes over governmental immunity involve vicarious liability for the governmental employees whose conduct is

at issue in such cases. (You may recall the “zany meat inspector hypo” in which a USDA employee jumped on the back of a friend, pulled the wool over his eyes and accidentally caused him to fall onto a meat hook and sustain significant injuries. The issue there in *Lambertson v. United States* was whether the conduct qualified as a battery versus a negligent act; see Module 2’s materials on battery. However, there was another pair of key issues in that fact pattern the hypo did not reach: whether the government’s immunity would apply to the conduct, and if not, whether vicarious liability would attach or whether the act was outside the scope of the employment from the start.)

Our first case turns to the scope of liability applicable to the government with respect to the discretion of the U.S. Forest Service in dealing with wildlife in parks.

The Discretionary Function Exception to Governmental Immunity

George v. U.S., District Court of M.D. Alabama, Fourth Division (1990) (735 F. Supp. 1524)

The cases at bar arise from an alligator attack on Plaintiff, Kermit H. George, while he was swimming in the Open Pond Recreation Area of the Conecuh National Forest. Plaintiff, Janet H. George, seeks recovery for loss of consortium. Plaintiffs bring this action against the United States of America pursuant to the Federal Tort Claims Act, 28 U.S.C. §§ 2671, et seq. [hereinafter the Act]. [***] [Court’s Note: Pursuant to the agreement of the parties, this Court bifurcated the issue of damages pending a determination of whether liability existed.]

Mr. George was injured on July 26, 1986, in the Open Pond Recreation Area of the Conecuh National Forest. The recreation area, which includes a designated swimming area, is owned and operated by the United States Forest Service. On the day of the attack, Mr. George and his unleashed dog entered the area from the rear entrance and proceeded around the park to the swimming area. Mr. George’s dog preceded Mr. George into the water and then exited sometime after Mr. George had waded approximately chest deep into the designated swimming area. Shortly after his entrance into the water, Mr. George was attacked by a large alligator, which ultimately severed Mr. George’s right arm at the shoulder.

The Forest Service officials admit that they had knowledge of the presence in the Open Pond Area of the 11–to–12–foot alligator which attacked Mr. George. The evidence showed that, of the 74 confirmed, nonfatal alligator attacks in the neighboring State of Florida, 53 were committed by alligators in excess of five feet in length. Furthermore, Forest Service officials admit *1526 that they had received several complaints concerning the alligator prior to the attack on Mr. George. Additionally, the Government admits that it neither posted signs warning of the alligator nor attempted to remove said alligator.

Joe Brown, Forest Supervisor of all national forests in Alabama, Larry Hedrick, Wildlife Biologist for the Forest Service, Buddie Risner, Acting District Ranger for the Conecuh National Forest, John Maurer, Forest Technician, and Harris LeMaire, Forest Technician, were all employed by the United States Forest Service and were working within the scope of their employment as federal employees at all times relevant to these cases. All were aware of the presence of a large alligator, presumably the

one which attacked Mr. George, in and near Open Pond within the seven-week period preceding the attack on Mr. George, which occurred on July 26, 1986. Their knowledge came from the following reports and observations [as well as at least 6 prior instances in which these entities saw firsthand, or received and reported complaints and concerns about large alligators, including at least two reports of alligators following people (one of which stated that a woman was followed 100 yards by a large alligator in the edge of the water). These reports repeatedly stated that the alligators appeared to have no fear of humans.]

During June and July, 1986, [various U.S. Forest Service officials] discussed the presence of a large alligator in and near Open Pond as reported and observed and the appropriate course of action to take regarding the alligator. [They] decided to take no immediate action other than monitoring the situation for several policy reasons, including their information that the alligator [***] had been in the area for many years and that the alligator had not attacked humans or domestic animals. They also were aware that the alligator was a protected species. [They] also believed that posting warning signs might suggest to the public that all potential natural dangers or risks would be posted. Finally, they thought that the risk of an alligator attack was minimal and that warning signs would unnecessarily frighten the public.

[T]he Government contends that the discretionary function exception [28 U.S.C. § 2680(a)] bars recovery. Finally, the Government asserts that Mr. George was contributorily negligent in either allowing his dog to enter the park unleashed, which was in violation of posted park regulations, or going swimming in an area Mr. George knew to be inhabited by alligators. [c]

DISCRETIONARY FUNCTION. Title 28 U.S.C. § 2680(a), provides that jurisdiction pursuant to 28 U.S.C. § 1346(b) shall not apply to:

“Any claim based upon an act or omission of an employee of the Government, exercising due care, in the execution of a statute or regulation, whether or not such statute or regulation be valid, or based upon the exercise or performance or the failure to exercise or perform a discretionary function or duty on the part of a federal agency or an employee of the Government, whether or not the discretion involved be abused.”

***1528** Plaintiffs have alleged that Defendant was negligent in failing to warn users of the Open Pond area of the presence of alligators and/or failing to remove the alligator that attacked Mr. George in the swimming area. Defendant argues that such decisions are discretionary and, thus, insulated from liability by virtue of § 2680. The thrust of Defendant’s argument stems from its contention that the forest officials charged with supervision of the Conecuh National Forest were of the opinion that neither the alligator which attacked Mr. George nor any other alligator presented any danger to the persons who used the recreation areas. In support of this contention, Defendant introduced testimony by several forest officials that there had been only one confirmed alligator attack on a human in the Conecuh National Forest prior to the attack on Mr. George. Furthermore, the prior attack had been instigated by a blind alligator with a clubfoot which, subsequent to the attack, was captured and transported to South Carolina.¹⁵⁶

¹⁵⁶ The evidence showed that Donna Jean Loman was attacked by this alligator in 1981. After the attack, this particular alligator was captured and released five miles from Open Pond in Yellow River. In 1983, another swimmer claimed

The forest officials admit that they were aware of the presence of the alligator which attacked Mr. George for some time but that this particular alligator had exhibited no signs of aggressive behavior toward humans. Additionally, the forest officials state they had no knowledge of any incidents concerning the alligator that would require them to take remedial action.

Forest officials based their determination on the fact that the alligator which attacked Mr. George had merely been following park guests and employees. However, at least one witness, Warren Brown, testified that, while he was snorkeling in Open Pond, an alligator chased him onto the shore and “hissed” at him. Mr. Brown reported this incident to Forest Service officials sometime in 1983 or 1984. Additionally, Plaintiffs’ expert, Dr. Robert Mount, testified that alligators typically catch their prey by stealth as opposed to exhibiting obvious aggressive behavior.

Upon considering whether or not remedial measures were required, forest officials determined that the alligator(s) posed no threat to the park visitor or, at least, no more of a threat than poisonous snakes and other natural hazards which one would expect to be present in a national forest located in South Alabama. Based on these facts, coupled with specific regulations dealing with the removal of alligators, Defendant argues that the forest officials’ decision to neither remove the alligator, erect barriers around the designated swimming area, nor to post any warning signs was a discretionary function and, as such, shields the Government by virtue of § 2680(a), from tort liability under the Act.

This Court finds by a preponderance of the evidence that at least six incidents of aggressive alligator behavior had been reported to various forest officials. Additionally, the District Ranger of Conecuh National Forest from November, 1975, until May, 1986, William Gilder, testified that he reported the alligator problem to the Forest Service headquarters in Montgomery by letter of October 9, 1985, and suggested that signs be posted. Accordingly, this Court must determine if the discretionary function doctrine bars Plaintiffs’ instant suit, notwithstanding this Court’s finding that the Forest Service had actual knowledge of the alligator problem and failed to take any corrective or preventative measures.

***1529** The hallmark case expounding on and interpreting the discretionary function exception of § 2680 is *Dalehite v. United States*, 346 U.S. 15, 35–36, 73 S.Ct. 956, 967–968, 97 L.Ed. 1427 (1953), wherein the Court stated:

“It is unnecessary to define, apart from this case, precisely where discretion ends. It is enough to hold, as we do, that the ‘discretionary function or duty’ that cannot form a basis for suit under the Tort Claims Act includes more than the initiation of programs and activities. It also includes determinations made by executives or administrators in establishing plans, specifications or schedules of operations. Where there is room for policy judgment and decision there is discretion. It necessarily follows that acts of subordinates in carrying out the operation of government in accordance with official directions cannot be actionable.”

In finding that no liability existed with respect to a fertilizer explosion, the *Dalehite* Court distinguished between decisions “made at a planning rather than operational level.” *Id.*, at 42, 73 S.Ct.

that he was bitten on the arm by an alligator. Mr. John Maurer, Forest Technician at the Conecuh National Forest in 1983, investigated his allegations and concluded that he had not been attacked by an alligator but, rather, had been stabbed in the arm with a barbecue fork by his wife during a domestic dispute. Notwithstanding Mr. Maurer’s conclusions as to that incident, the clubfooted alligator was again trapped and removed to South Carolina.

at 971. The *Dalehite* Court further found that the Government had no knowledge of a probable danger with respect to the handling of the fertilizer. *Id.*

The Supreme Court in [***] *Berkovitz v. United States*, 486 U.S. 531, 108 S.Ct. 1954, 100 L.Ed.2d 531 (1988) ... further refined the factors to be considered in determining whether the Government's conduct is protected by § 2680. The Court stated:

“[***] [C]onduct cannot be discretionary unless it involves an element of judgment or choice. [c] Thus, the discretionary function exception will not apply when a federal statute, regulation, or policy specifically prescribes a course of action for an employee to follow. In this event, the employee has no rightful option but to adhere to the directive. And if the employee's conduct cannot appropriately be the product of judgment or choice, then there is no discretion in the conduct for the discretionary function exception to protect. [c]. * * *

“Moreover, assuming the challenged conduct involves an element of judgment, a court must determine whether that judgment is of the kind that the discretionary function exception was designed to shield. The basis for the discretionary function exception was Congress' desire to 'prevent judicial second-guessing of legislative and administrative decisions grounded in social, economic, and political policy through the medium of an action in tort.' [c] The exception, properly construed, therefore, protects only governmental actions and decisions based on considerations of public policy. ... ('Where there is room for policy judgment and decision there is discretion'). In sum, the discretionary function exception insulates the Government from liability if the action challenged in the case involves the permissible exercise of policy judgment.”
[c]

The test to be applied to the cases at bar is, thus, whether the forest officials had discretion to make the choice of not taking any remedial measures with respect to the alligator problem, and, if so, whether such choice was one which Congress intended to shield from liability by virtue of § 2680(a).

[***] In *Bowman v. United States*, 820 F.2d 1393 (4th Cir.1987), plaintiff drove his vehicle off a federally-controlled parkway in the Shenandoah National Park. *Id.*, at 1393. The plaintiff contended that the Government was negligent in failing to erect guardrails along the parkway or in failing to post signs warning of the steep embankment. The Court, in affirming the district court's dismissal of the case, held that the discretionary function doctrine barred plaintiff's suit. *Id.*, at 1395. The Court stated that whether the decision to take no action “grew out of a lack of financial resources, a desire to preserve the natural beauty of the vista, a judgment that the hazard was insufficient to warrant a guardrail, or a combination of all three is not known. What is obvious is that the decision was the result of a policy judgment.” *Id.* However, the Court clearly pointed out that the danger was open and obvious and, further, that the primary purpose of the parkway was “not to facilitate transportation and travel”.

In the cases at bar, the presence of the alligator was not open and obvious to a person who chose to use the swimming area. Furthermore, one of the primary purposes (if not the primary purpose) of the national forest was to provide a recreation area for individuals who chose to visit the park. These two factors clearly distinguish *Bowman* from the instant cases. [***]

In the cases at bar, several of the forest officials testified that the alligator involved in this attack had lost his fear of man. Therefore, Defendant consciously disregarded a known risk by failing to take any steps whatsoever to protect users of the swimming area.

Based on the authority cited hereinbefore, it is the opinion of this Court that ***1533** no reasonable range of choices existed as to the failure to take some action and, thus, the discretionary function exception is inapplicable. 28 U.S.C. § 1346(b) provides:

“Subject to the provisions of Chapter 171 [discretionary function exception] of this title, the district courts * * * shall have exclusive jurisdiction of civil actions on claims against the United States, * * * for injury * * * or death caused by the negligent or wrongful act or omission of any employee of the Government while acting within the scope of his office or employment, under circumstances where the United States, if a private person, would be liable to the claimant in accordance with the law of the place where the act or omission occurred.”

In this Court’s opinion, the fact that the Government chose not to guard or warn of the alligator(s) does not invoke the protection of § 2680(a). Based on the evidence presented to this Court, no element of choice was presented when the Government failed to remove or warn of the presence of alligator(s) in the swimming area. Thus, § 2680(a) does not apply. Since the danger presented by the reptile(s) was known by the forest officials, there was no discretion to fail to take any remedial measures. Surely, it cannot be contended that the forest officials had discretion to decide whether overriding policy considerations of protecting the alligator(s) and the natural state of the area outweighed the safety of humans using the designated swimming area. Despite the fact that regulations were in place to not only protect the alligator(s), which at the time of this incident were on the endangered species list, but to also preserve the natural state of the park, this Court finds that the existence of such does not invoke the protection of § 2680 in derogation of the rights of humans.

Irrespective of the existence of such regulation and the interpretation thereof, it cannot be gainsaid that the Government, the same as a private individual, is under a duty to protect others from hidden dangers they are unaware of when such dangers pose a significant risk of serious bodily injury or death. Thus, no choice presented itself to the forest officials as to whether or not to take remedial measures to protect the individuals using the area.

This Court concedes that the decisions of whether to have a swimming area and what measures to take to protect individuals once the alligator problem arose were vested within the sound discretion of the Forest Service and, thus, protected from “judicial second-guessing” by § 2680. However, the decision to do nothing in spite of the known danger was not an option, in this Court’s opinion, the Forest Service had available to them. To contend that the decision to do nothing was discretionary because the Forest Service was under an affirmative duty to protect the alligator(s) and the scenic beauty of the park is ludicrous. If this Court were to hold that the discretionary function exception barred Plaintiffs’ suits, it would, in effect, be elevating the well-being of an alligator to a level deserving more protection than that of a human. The park was obviously built to provide a recreational area for those desiring to use such, not as a wildlife habitat where the safety of humans through their incidental use takes a back seat to the viewing of reptiles in their natural habitat. If the Forest Service were desirous of this result, it would not have created the recreational areas. The decision to do so was discretionary, but once the decision was made, the Forest Service was under a duty to act reasonably for protection of humans,

particularly against hidden dangers known to the Service. Failing such standard, the Government is liable to Plaintiffs in the cases at bar. Accordingly, it is the opinion of this Court that no reasonable range of choices existed with respect to the Forest Service's inaction, and, as such, the discretionary function doctrine of 28 U.S.C. § 2680(a) is inapplicable. Therefore, this Court finds that the Government's discretionary function defense must fail.

[***] CONTRIBUTORY NEGLIGENCE. Defendant's final arguments in support of a finding in its favor concern two separate and independent contentions of contributory negligence on the part of Mr. George. Defendant's first contention is that Mr. George was aware of the presence of alligator(s) in Open Pond and, thus, assumed the risk of injury when he entered the swimming area. Defendant's second theory of contributory negligence arises from Mr. George's failure to have his dog on a leash while in the park which, thus, allowed the dog to precede Mr. George into the swimming area. Defendant contends that the presence of the dog attracted the alligator into the swimming area. This Court is of the opinion that both of Defendant's contentions are without merit.

Mr. George testified that he knew alligators were present in Open Pond but that he was unaware that there were any the size of the reptile that took his arm. This Court finds by a preponderance of the evidence that Mr. George was not aware that an alligator approximately 11 feet in length inhabited the Open Pond waters. Furthermore, this Court finds that Mr. George had no knowledge of the danger presented by his entering the swimming area. Thus, this Court finds that Mr. George did not assume the risk of his injury by entering the swimming area on July 26, 1986, notwithstanding his knowledge of the presence of alligators in Open Pond.

As briefly set forth previously, Defendant's second theory of contributory negligence arises from the fact that Mr. George violated park regulations by allowing his unleashed dog to accompany him into the park on the occasion in question. The asserted contributory negligence is that Mr. George violated the National Park's leash law and that this violation was a proximate cause of the loss of his arm and related damages. The fact that Mr. George's dog violated regulations by being unleashed is and was of little interest to *1536 this Court or to the subject alligator. It may be speculated that the dog's presence lured the alligator to Mr. George. There is some evidence that alligators are known to enjoy dog meat, but the preponderance of the evidence shows that alligators are not discriminatory in their tastes and are well known to dine on whatever is convenient. The presence in this alligator's stomach of fish stringers, a broken bottle neck and a pine cone is ample evidence that, had the dog been convenient, the leash would not have interfered with the alligator's breakfast, whether or not this particular alligator had a preference for dog meat. This Court finds that the fact, that Mr. George violated park regulations by not keeping his dog on a leash in the park, was not a proximate or contributing cause to his injuries and damages.

Therefore, this Court finds that the Government is liable to the Plaintiffs. An Order will be entered in accordance with this Opinion.

Note 1. The court articulates the two-step test for applying the discretionary function exception: (1) whether the officials in question **had discretion to make choices** and (2) whether such choice was one which **Congress intended to shield from liability** by virtue of § 2680(a). Recall the purposes behind the FTCA as stated at the start of this section. What sorts of choices do you think are likely to be shielded from liability?

Note 2. The question of discretion exists to protect decisional autonomy under the same rationale applied to the protection of parental autonomy under theories that supported parental immunity.

In *Smelser v. Paul*, *supra* the court likens parental immunity to governmental immunity. In a section edited out of that opinion, it writes about both: “the purpose of immunity is to provide sufficient breathing space for making discretionary decisions, by preventing judicial second-guessing of such decisions through the medium of a tort action.”

One could carry the analogy further. Where some parental immunity has been retained, it is in spheres in which policymakers *intended to shield parents from liability*, such as the core decisions involved with raising children. Whether to come to a full or a rolling stop at a stop sign, or how well to maintain the brakes on one’s automobile, are not the kind of choice that policymakers wished to shield from liability (or wish to shield, in the jurisdictions that retain some form of parental immunity). Do you agree with the court that parental and governmental decision making are sufficiently similar to analogize in this way? Even if both require breathing space, do both deserve it equally? Is the case stronger for parents or governments, in your view?

Note 3. A persistent complexity in cases involving the discretionary function exception is whether choosing not to take affirmative steps in a given case is a legitimate choice, that is, one of the choices protected under this form of immunity. Or in the alternative, is doing nothing *not* one acceptable choice among many but rather a breach of duty in the form of nonfeasance? The answers are highly fact-dependent and do not produce a coherent body of case law with a general rule.

In *George*, the court identifies the government’s duty “to protect others from hidden dangers they are unaware of when such dangers pose a significant risk of serious bodily injury or death” and concludes that it was not a choice the forest service officials could make, to refrain from taking remedial measures. It clarified that “the decisions of *whether* to have a swimming area and *what measures to take* to protect individuals once the alligator problem arose were vested within the sound discretion of the Forest Service and, thus, protected from ‘judicial second-guessing’ by § 2680” (my emphasis). Would the case have come out differently if the Forest Service had made halfhearted, ineffective attempts to address the alligator problem? What do you imagine is the easiest (lowest burden) set of steps the Forest Service could have taken if it wanted its discretion preserved under this ruling? Was *George* effectively holding the Forest Service strictly liable for the presence of this large, aggressive alligator? If so, what conduct would you expect to see from the Forest Service in the future?

Note 4. What is the government’s theory of contributory negligence against George and why does it fail?

Exam tip: When analyzing governmental immunity and the applicability of the discretionary function exception to waiver of sovereign immunity under the FTCA, be sure to **evaluate *both* prongs of the two-step test** set out at § 2680! First, did the government actors in question have **discretion** to make choices? Second, were the choices over which they had discretion **the kind Congress intended to shield from liability** through § 2680(a)? It is easy for students to get lost in the analysis of whether there was sufficient discretion or choice under prong one and to forget to complete the analysis required under prong two. That’s an important oversight because the second prong sets the scope of the discretion and failing to attend to it would make the discretionary function exception swallow the rule.

Check Your Understanding (4-5)

Question 1. On what grounds does the court in *George* hold that § 2680 does not apply?

An interactive H5P element has been excluded from this version of the text. You can view it online here: <https://saidtorts2d.lawbooks.cali.org/?p=72#h5p-102>

Question 2. A large nest of so-called “murder hornets” was discovered by a U.S. Forest Ranger in a park under their jurisdiction in Washington state. The nest contained scads of these rare, extremely dangerous insects. A person with a hornet sting allergy who visits this park is stung and severely injured by the encounter with one of these murder hornets two weeks after the ranger has done nothing to warn the public or to remove the nest. Under the FTCA’s waiver of governmental immunity it is possible that the ranger’s conduct could result in liability being allocated to the United States on a theory of vicarious liability. However, if the FTCA’s § 2680 discretionary function exception applies, the ranger’s conduct will fall outside the FTCA’s waiver of immunity (thus making the U.S. government immune from liability in this case).

Note: Ordinarily, under the second step of discretionary function analysis, you would need to determine whether decisions about insect management and other wildlife in federally administered state parks is the kind of discretionary decision making that Congress sought to shield from liability under the FTCA’s § 2680. However, for this question, you may assume it is *generally* the kind of discretionary decision making Congress sought to protect through enactment of the discretionary function exception.

Which of the following selections is most likely to *fail to qualify* for the protection of the discretionary function exception?

An interactive H5P element has been excluded from this version of the text. You can view it online here: <https://saidtorts2d.lawbooks.cali.org/?p=72#h5p-103>

Revisit the facts of *Garrison v. Deschutes* (Module 3, Causation), in which the Supreme Court of Oregon held that it was not negligent when Gary Garrison was severely injured in a fall at the Fryrear transfer station, in part because the defendant’s failure to warn had not *caused* Garrison’s injuries. Recall that there were two other issues mentioned but omitted from that version of the opinion: allegedly negligent design and governmental immunity. We turn to those now.

Garrison v. Deschutes Cty., Supreme Court of Oregon (2002) (334 Or. 264)

This personal injury case requires us to examine the scope of the immunity from liability that the Oregon Tort Claims Act (OTCA) grants to certain kinds of discretionary decisions of a public body. The case arose when plaintiff Gary Garrison¹⁵⁷ was injured when he fell from a raised concrete slab onto a lower slab at a Deschutes County (county) refuse transfer station. Plaintiffs brought the present action against the county, alleging three specifications of negligence. The county moved for summary judgment, asserting that, by virtue of ORS 30.265(3)(c) ... it was immune from liability for the acts that plaintiffs alleged. The trial court agreed. On plaintiffs' appeal, the Court of Appeals affirmed, holding that: (1) the doctrine of qualified immunity protected the exercise of discretion by county employees in designing the transfer station; and (2) the county's failure to warn plaintiffs of the obvious danger of falling off the higher slab did not expose plaintiffs to a greater risk of harm than if they had been warned. *Garrison v. Deschutes County*, 162 Or.App. 160 (1999). We allowed plaintiffs' petition for review and now affirm. [***]

A private landowner or occupier of land in a position similar to the county's would be required to take care to protect patrons on the premises from injuries resulting from known, dangerous conditions on the premises or, at least, to warn them of the danger. *Woolston v. Wells*, 297 Or. 548, 557-58 (1984). [***] The county is not a private entity, however. The question before the court, therefore, is whether the fact that *273 the refuse station is not privately owned and operated alters the analysis. The answer to that question lies in the applicability of the OTCA, ORS 30.260 *et seq.*, which provides that public bodies generally are liable for their torts, except in certain limited circumstances.

In this case, the county has asserted throughout that one of those circumstances pertains here. It contends that it is entitled to "discretionary function" immunity under ORS 30.265(3)(c), which we again set out here for the convenience of the reader. That subsection provides, in part:

"Every public body and its officers, employees and agents acting within the scope of their employment or duties * * * are immune from liability for:

" * * * * *

"(c) Any claim based upon the performance of or the failure to exercise or perform a discretionary function or duty, whether or not the discretion is abused."

By its terms, ORS 30.265(3)(c) confers immunity on the county, as a public body, from liability for the negligent performance or nonperformance of a "discretionary function or duty." The OTCA does not define that phrase. However, the statute's meaning and scope have been fleshed out through years of litigation. For example, this court has discussed the meaning of the term "discretion" in ORS 30.265(3)(c) on several occasions. In *McBride v. Magnuson*, 282 Or. 433, 437 (1978), the court stated that conduct is "discretionary" in the sense that immunity attaches to its negligent performance if the decision is the result of a choice among competing policy considerations, made at the appropriate level of government:

¹⁵⁷ Plaintiffs are Gary Garrison, who seeks damages for his own injuries, and Heather Garrison, his wife, who seeks damages for loss of consortium.

“[I]nsofar as an official action involves both the determination of facts and simple cause-and-effect relationships and also the assessment of costs and benefits, the evaluation of relative effectiveness and risks, and a choice among competing goals and priorities, an official has ‘discretion’ to the extent that he has been delegated responsibility for the latter kind of value judgment.”

This court also has stated that ORS 30.265(3)(c) extends immunity “to decisions involving the making of policy, but *274 not to routine decisions made by employees in the course of their day-to-day activities, even though the decision involves a choice among two or more courses of action.” [c]

Notwithstanding the foregoing, the court has stated that the “discretionary immunity” doctrine does not immunize a decision not to exercise care at all, if action of *some* kind is required:

“A public body that owes a particular duty of care * * * has wide policy discretion in choosing the means by which to carry out that duty. * * * The range of permissible choices does not, however, include the choice of not exercising care.” *Mosley v. Portland School Dist. No. 1J*, 315 Or. 85, 92, (1992) (citations omitted).

In other words, the decision *whether* to protect the public by taking preventive measures, or by warning of a danger, if legally required, is not discretionary; however, the government’s choice of *means* for fulfilling that requirement may be discretionary. [cc]

Moreover, only those decisions that are made by officials in a position of authority are immune from liability. [***] However, in assessing whether, in a particular case, a decision was made by the kinds of decision-makers to whom the statutory immunity was intended to extend, the emphasis properly is on the nature of the decision-making, not necessarily the level of office. “Although policy discretion is *more likely* to be found at or near the level of political responsibility, it is not simply a matter of the defendant’s office but of the scope and nature of the choices delegated to him.” [c] [***] *275

With the foregoing standards in mind, we turn to the facts of the present case to evaluate whether the decision to build and maintain the refuse transfer station without erecting barriers at the edge of the platform that might prevent people from falling and the decision to design the station so as to require people using the facility to back a vehicle onto the platform to dump refuse were decisions that involved the making of policy by people who had been delegated the authority to make that type of policy judgment.

Driver’s affidavit, which is undisputed, demonstrates that he and Rice, in the course of selecting a design for the transfer station, made various decisions that were of a type that this court previously has considered to be “discretionary” or “the making of policy”: They considered various design options for the station; they evaluated the relative effectiveness, safety and risks, as well as the relative costs and benefits, of constructing the station with and without the platform; they also considered the added maintenance and resulting cost of adding a fence, railing, or other barrier to the platform, as well as whether adding a fence, railing, or other barrier would make the platform more difficult or more dangerous to use. In the end, they concluded that the design that they ultimately chose—a platform that required users to back a vehicle up to dump refuse, with no barrier other than the railroad tie to protect users from falling—was the safest, least expensive, *276 and easiest to use. Thus, in selecting the final design under those criteria, Rice and Driver exercised the kind of discretion that ORS 30.265(3)(c)

protects—a protection that extends to the county’s operation of the refuse transfer station in accordance with that design.

Plaintiffs have attempted to characterize that final design decision differently. They contend that the county had a duty to protect the public and that the county did not satisfy that duty merely by “considering” public safety and then deciding that safety measures would not be adopted, whether due to expense, inconvenience, or some other reason. In effect, plaintiffs assert that the county owed a duty of care to the public that used the refuse transfer station and simply chose not to exercise care. Under this court’s decision in *Mosley*, they contend, that choice was not within the permissible range of options available to the county and, therefore, was not entitled to immunity.

Plaintiffs’ argument is premised on a mischaracterization of the undisputed facts. According to Driver’s affidavit, Driver and Rice actively considered the relative risks and benefits of including in the final design just the sort of fall protection devices that plaintiffs contend are required to protect the public. For various reasons, Driver and Rice concluded that protective barriers actually would make the platform *less safe*. We assume for purposes of this opinion that that conclusion might have been both wrong and negligently reached. Nonetheless, the uncontroverted evidence of that thinking process establishes conclusively that this is not a case in which the decision-makers simply disregarded their duty to protect the public. On the contrary, with their decision, even if it was flawed, they exercised their discretion and chose to protect the public in a particular way. Plaintiffs wish to argue that the county should have done something more, or something different, but that argument is the kind of second-guessing that is defeated by immunity under ORS 30.265(3)(c).

The decision of the Court of Appeals and the judgment of the circuit court are affirmed.

***280** DURHAM, J., dissenting.

For the reasons stated below, I believe that the majority misapplies the statutory immunity for the performance of a “discretionary function or duty” set out in ORS 30.265(3)(c). [***] Plaintiffs contend that, on the date of the accident, defendant invited the public to use its refuse facility and that plaintiffs were business invitees at the time of the accident. According to plaintiffs, defendant knew that the large concrete garbage pit on the premises created an unreasonably dangerous condition due to the lack of any fall protection device, but failed to use reasonable care to eliminate the risk of injury to invitees or to warn of the danger.

Plaintiffs’ claim invokes the legal duty owed by a land occupier to business invitees. This court summarized that duty in *Woolston v. Wells*, 297 Or. 548, 557-58 (1984):

“In general, it is the duty of the possessor of land to make the premises reasonably safe for the invitee’s visit. ***281** The possessor must exercise the standard of care above stated to discover conditions of the premises that create an unreasonable risk of harm to the invitee. The possessor must exercise that standard of care either to eliminate the condition creating that risk or to warn any foreseeable invitee of the risk so as to enable the invitee to avoid the harm.”

[***] Defendant’s duty to business invitees, as described in *Woolston*, is not a “discretionary function or duty,” to use the terms of ORS 30.265(3)(c).¹⁵⁸ Rather, defendant’s duty, as *282 summarized in *Woolston*, is nondiscretionary. That is, the law has made a policy choice, for defendant as well as all other landowners and occupiers who invite customers to enter their property, that mandates compliance with the legal duty described in *Woolston*. As this court explained in *Miller v. Grants Pass Irr. Dist.*, 297 Or. 312 (1984), a public body may have discretion in choosing how it will satisfy its duty to the public but it has no discretion to choose not to fulfill its legal duty:

“If there is a legal duty to protect the public by warning of a danger or by taking preventing measures, or both, the choice of means may be discretionary, but the decision whether or not to do so at all is, by definition, not discretionary.

“This is so whether the duty derives from statutory or from common law. * * * The law itself has made that much of a policy choice. When different precautions might satisfy this duty, however, the choice of which one to use may be discretionary.” *Id.* at 320.

The passage from *Miller*, quoted above, confirms that a public body has no discretion to decide whether to satisfy a legal duty imposed by Oregon common law. Defendant simply is incorrect in arguing (1) that the range of its permissible discretionary choices included the choice to do nothing to comply with the duty stated in *Woolston*, or (2) that its consideration of policy-related criteria, coupled with a choice to take no precautions against the risk of falls at the edge of the *284 pit, qualifies under *Miller* as a choice of means to satisfy the duty described in *Woolston*. [***]

More puzzling is the majority’s effort to portray defendant’s conduct as an “exercise [of] care” that defendant’s agents *believed* to be more safe than what plaintiffs sought. *Id.* The assertion that defendant did exercise care in designing the refuse pit contradicts the majority’s assumption that defendant’s decision to forego any fall protection devices “might have been both wrong and negligently reached.” *Id.* at 276. Moreover, because the case is before the court on summary judgment, we must construe the evidence in the light most favorable to plaintiffs. In view of the contention of plaintiffs’

¹⁵⁸ In his concurring opinion in *Miller v. Grants Pass Irr. Dist.*, 297 Or. 312, 323-24, 686 P.2d 324 (1984), Justice Lent opined that the notion of a “discretionary duty,” which the text of ORS 30.265(3)(c) embraces, is a contradiction in terms that detracts from a principled statutory analysis. He did, however, offer the following explanation, with which I agree, regarding the concepts of discretion and legal duty in the application of ORS 30.265(3)(c): “I do have trouble envisioning a discretionary duty. ORS 30.265(1), speaking generally, makes the state or a local public body liable for its torts. In order for there to be a tort the actor must breach some duty imposed by law, that is, by legislative enactment (statute, rule, regulation, charter, ordinance, etc.) or the common law. The duty must be identified and proclaimed to exist by a court, as a matter of law, not fact. A duty either exists or it does not. The law either commands someone to act, or refrain from acting, or it does not. In this case, the Irrigation District chose to build and operate a dam. Having done so, it should be held to the same duty as would any person, natural or corporate, have in the operation of a dam and the impoundment of water, to protect those on the water from an unreasonable risk of harm arising from the District’s activities in this respect. If legislation or the common law imposes a duty on a dam operator in these circumstances, there is nothing ‘discretionary’ about the existence of the duty, nor can it be described by that adjective. There may be, and probably is, room for discretion in choosing the manner of performance, both for a private person or a public agency, but the duty must be performed and the standard of care required by the duty must be achieved. To sum up, a discretionary function is one concerning which the governmental agency involved has power to make a choice among valid alternatives, but if there is a duty imposed by law there is no choice but to obey. If there is no duty, to which adherence is required, then the agency is concerned with a function rather than a duty. I really don’t know what a discretionary duty looks like.”

expert witness that the design of the refuse pit was unreasonably dangerous, the majority's conclusion that defendant exercised care is both irrelevant and impermissible.

Lastly, the mere belief of defendant's agents in the greater safety of their design is irrelevant. Plaintiffs rely on defendant's failure to take any precautions to eliminate the known risk that customers might fall into the refuse pit—a nondiscretionary legal duty imposed by Oregon law. *See Woolston*, 297 Or. at 557-58 (describing legal duty). While the confidence displayed by defendant's agents is understandable, it does not justify immunizing defendant for failing to adopt any precautions against a known risk of injury from falls, in accordance with Oregon law.

This is not a case in which defendant made a choice to use a device to protect against falls, but the device simply failed to function. Rather, defendant seeks discretionary immunity for its decision not to use any protection against the risk of falling, *i.e.*, choosing not to use reasonable care to “eliminate the condition creating that risk or to warn any foreseeable invitee of the risk so as to enable the invitee to avoid the harm.” *Id.* at 558. Defendant's argument, carried to *287 its logical conclusion, would immunize a public body's decision to disregard its nondiscretionary legal duty, simply because the public body believed that its policy reasons for avoiding its legal duty were superior to the policy reasons that supported creation of the legal duty in the first instance. The legislature did not intend that construction of ORS 30.265(3)(c).

Because defendant has not demonstrated that it is entitled to immunity from liability at this stage of the proceeding, the trial court should have denied defendant's motion for summary judgment. Accordingly, I respectfully dissent.

Note 1. “Discretion” is defined in *Garrison* to include: “both the determination of facts and simple cause-and-effect relationships and also the assessment of costs and benefits, the evaluation of relative effectiveness and risks, and a choice among competing goals and priorities.”

When cast in this way, the discretion would seem to consist of a huge range of government actions. Is the discretionary function exception more properly understood as a default to immunity, with only truly ministerial (non-discretionary) tasks subject to the possibility of tort liability?

Note 2. In finding the discretionary exception applied, the majority reasoned: “[T]he decision *whether* to protect the public by taking preventive measures, or by warning of a danger, if legally required, is not discretionary; however, the government's choice of *means* for fulfilling that requirement may be discretionary.” [cc] In some respects, this distinction parallels the dividing line between duty and breach; duty expresses a legal obligation and breach specifies what conduct the duty requires on a given set of facts. Does that dividing line seem to you to apply here?

Note 3. What are the dissent and the majority opinions arguing over? How is it that they cite some of the same cases for seemingly different purposes? Whose opinion is more persuasive to you?

4. Limits on Governmental Liability: The Public Duty Doctrine

Sovereign immunity has been waived by the federal, state, tribal and local governments with respect to many different functions, such as permitting recovery against negligently driving mail carriers, as you learned above. However, the scope of the duty owed by governments outside the clearly waived

immunity has not always been clear. To be sure, governmental immunity was partially to be waived but partially to be retained, but the question was, waived as to what? The flip side of this question was one of duty: to whom, and for what, did the government still owe a duty once it had waived its blanket immunity? Recall that at common law there was no duty “to rescue,” or to engage in certain affirmative steps unless particular relationships or contracts or categories imposed a duty. A doctrine known as “the public duty doctrine” arose to define and delimit a sphere of obligation to the public.

The next case features an abusive relationship, and violent actions by a rejected ex-boyfriend whose threats the police did not take seriously enough to act on before they resulted in serious physical injury. The court does not find liability and both the majority and dissenting opinions are notable for their deep discussions of policy with respect to the interconnections between duty and immunity.

Riss v. City of New York, New York Court of Appeals (1968) (22 N.Y.2d 579)

[Editor’s Note: The description of the facts in this case is taken from the dissenting opinion of Judge Keating (which the majority opinion points to, in omitting its own discussion of the facts).]

Linda Riss, an attractive young woman, was for more than six months terrorized by a rejected suitor well known to the courts of this State, one Burton Pugach. This miscreant, masquerading as a respectable attorney, repeatedly threatened to have Linda killed or maimed if she did not yield to him: ‘If I can’t have you, no one else will have you, and when I get through with you, no one else will want you.’ In fear for her life, she went to those charged by law with the duty of preserving and safeguarding the lives of the citizens and residents of this State. Linda’s repeated and almost pathetic pleas for aid were received with little more than indifference. Whatever help she was given was not commensurate with the identifiable danger. On June 14, 1959 Linda became engaged to another man. At a party held to celebrate the event, she received a phone call warning her that it was her ‘last chance.’ Completely distraught, she called the police, begging for help, but was refused. The next day Pugach carried out his dire threats in the very manner he had foretold by having a hired thug throw lye in Linda’s face. Linda was blinded in one eye, lost a good portion of her vision in the other, and her face was permanently scarred. After the assault the authorities concluded that there was some basis for Linda’s fears, and for the next three and one-half years, she was given around-the-clock protection.”

This appeal presents, in a very sympathetic framework, the issue of the liability of a municipality for failure to provide special protection to a member of the public who was repeatedly threatened with personal harm and eventually suffered dire personal injuries for lack of such protection. ... The issue arises upon the affirmance by a divided Appellate Division of a dismissal of the complaint, after both sides had rested but before submission to the jury. It is necessary immediately to distinguish those liabilities attendant upon governmental activities which have displaced or supplemented traditionally private enterprises, such as are involved in the operation of rapid transit systems, hospitals, and places of public assembly. Once sovereign immunity was abolished by statute the extension of liability on ordinary principles of tort law logically followed. To be equally distinguished are certain activities of government which provide services and facilities for the use of the public, such as highways, public buildings and the like, in the performance of which the municipality or the State may be liable under

ordinary principles of tort law. The ground for liability is the provision of the services or facilities for the direct use by members of the public.

In contrast, this case involves the provision of a governmental service to protect the public generally from external hazards and particularly to control the activities of criminal wrongdoers. [cc] The amount of protection that may be provided is limited by the resources of the community and by a considered legislative-executive decision as to *582 how those resources may be deployed. For the courts to proclaim a new and general duty of protection in the law of tort, even to those who may be the particular seekers of protection based on specific hazards, could and would inevitably determine how the limited police resources of the community should be allocated and without predictable limits. This is quite different from the predictable allocation of resources and liabilities when public hospitals, rapid transit systems, or even highways are provided. Before such extension of responsibilities should be dictated by the indirect imposition of tort liabilities, there should be a legislative determination that that should be the scope of public responsibility. It is notable that the removal of sovereign immunity for tort liability was accomplished after legislative enactment and not by any judicial arrogation of power (Court of Claims Act, §8). [***]

When one considers the greatly increased amount of crime committed throughout the cities, but especially in certain portions of them, with a repetitive and predictable pattern, it is easy to see the consequences of fixing municipal liability upon a showing of probable need for and request for protection. To be sure these are grave problems at the present time, exciting high priority activity on the part of the national, State and local governments, to which the answers are neither simple, known, or presently within reasonable controls. To foist a presumed cure for these problems by judicial innovation of a new kind of liability in tort would be foolhardy indeed and an assumption of judicial wisdom and power not possessed by the courts. *583 [***] For all of these reasons, there is no warrant in judicial tradition or in the proper allocation of the powers of government for the courts, in the absence of legislation, to carve out an area of tort liability for police protection to members of the public. Quite distinguishable, of course, is the situation where the police authorities undertake responsibilities to particular members of the public and expose them, without adequate protection, to the risks which then materialize into actual losses [c].

Accordingly, the order of the Appellate Division affirming the judgment of dismissal should be affirmed.

KEATING, JUDGE (dissenting)

Certainly, the record in this case, sound legal analysis, relevant policy considerations and even precedent cannot account for or sustain the result which the majority have here reached. For the result is premised upon a legal rule which long ago should have been abandoned, having lost any justification it might once have had. Despite almost universal condemnation by legal scholars, the rule survives, finding its continuing strength, not in its power to persuade, but in its ability to arouse unwarranted judicial fears of the consequences of overturning it.

No one questions the proposition that the first duty of government is to assure its citizens the opportunity to live in personal security. And no one who reads the record of Linda's ordeal can reach a conclusion other than that the City of New York, acting through its agents, completely and negligently failed to fulfill this obligation to Linda.

Linda has turned to the courts of this State for redress, asking that the city be held liable in damages for its negligent failure to protect her from harm. With compelling logic, she can point out that, if a stranger, who had absolutely no obligation to aid her, had offered her assistance, and thereafter Burton Pugach was able to injure her as a result of the negligence of the volunteer, the courts would certainly require him to pay damages. (Restatement, 2d, Torts, § 323.) Why then should the city, whose duties are imposed by law and include the prevention of crime (New York City Charter, § 435) and, consequently, extend far beyond that of the Good Samaritan, not be responsible? If a private detective acts carelessly, no one would deny that a jury could find such conduct unacceptable. Why then is the city not required to live up to at least the same minimal standards of professional competence which would be demanded of a private detective?

Linda's reasoning seems so eminently sensible that surely it must come as a shock to her and to every citizen to hear the city argue and to learn that this court decides that the city has no duty to provide police protection to any given individual. What makes the city's position particularly difficult to understand is that, in conformity to the dictates of the law, Linda did not carry any weapon for self-defense (former Penal Law, §1897). Thus, by a rather bitter irony she was required to rely for protection *585 on the City of New York which now denies all responsibility to her.

It is not a distortion to summarize the essence of the city's case here in the following language: "Because we owe a duty to everybody, we owe it to nobody." [***] To say that there is no duty is, of course, to start with the conclusion. The question is whether or not there should be liability for the negligent failure to provide adequate police protection. The foremost justification repeatedly urged for the existing rule is the claim that the State and the municipalities will be exposed to limitless liability. The city invokes the specter of a "crushing burden" (Steitz v. City of Beacon, 295 N. Y. 51, 55) if we should depart from the existing rule and enunciate even the limited proposition that the State and its municipalities can be held liable for the negligent acts of their police employees in executing whatever police services they do in fact provide (cf. dissenting opn. per Desmond, J., in Steitz v. City of Beacon, citation omitted).

The fear of financial disaster is a myth. The same argument was made a generation ago in opposition to proposals that the State waive its defense of "sovereign immunity". The prophecy proved false then and it would now. The supposed astronomical financial burden does not and would not exist. No municipality has gone bankrupt because it has had to respond in damages when a policeman causes injury through carelessly driving a police car or in the thousands of other situations where, by judicial fiat or legislative enactment, the State and its subdivisions have been held liable for the tortious conduct of their employees. Thus, in the past four or five years, New York City has been presented with an average of some 10,000 claims each year. The figure would sound ominous except for the fact the city has been paying out less than \$8,000,000 on tort claims each year and this amount includes all those sidewalk defect and snow and ice cases about which the courts fret so often. [c] Court delay has reduced the figure paid *586 somewhat, but not substantially. Certainly this is a slight burden in a budget of more than six billion dollars (less than two tenths of 1%) and of no importance as compared to the injustice of permitting unredressed wrongs to continue to go unrepaired. That Linda Riss should be asked to bear the loss, which should properly fall on the city if we assume, as we must, in the present posture of the case, that her injuries resulted from the city's failure to provide sufficient police to protect Linda is contrary to the most elementary notions of justice.

The statement in the majority opinion that there are no predictable limits to the potential liability for failure to provide adequate police protection as compared to other areas of municipal liability is, of course, untenable. When immunity in other areas of governmental activity was removed, the same lack of predictable limits existed. Yet, disaster did not ensue.

Another variation of the “crushing burden” argument is the contention that, every time a crime is committed, the city will be sued and the claim will be made that it resulted from inadequate police protection. Here, again, is an attempt to arouse the “anxiety of the courts about new theories of liability which may have a far-reaching effect” [c]. And here too the underlying assumption of the argument is fallacious because it assumes that a strict liability standard is to be imposed and that the courts would prove completely unable to apply general principles of tort liability in a reasonable fashion in the context of actions arising from the negligent acts of police and fire personnel. The argument is also made as if there were no such legal principles as fault, proximate cause or foreseeability, all of which operate to keep liability within reasonable bounds.

No one is contending that the police must be at the scene of every potential crime or must provide a personal bodyguard to every person who walks into a police station and claims to have been threatened. They need only act as a reasonable man would under the circumstances. At first there would be a duty to inquire. If the inquiry indicates nothing to substantiate the alleged threat, the matter may be put aside and other matters attended to. If, however, the claims prove to have some basis, appropriate steps would be necessary. *587

The instant case provides an excellent illustration of the limits which the courts can draw. No one would claim that, under the facts here, the police were negligent when they did not give Linda protection after her first calls or visits to the police station in February of 1959. The preliminary investigation was sufficient. If Linda had been attacked at this point, clearly there would be no liability here. When, however, as time went on and it was established that Linda was a reputable person, that other verifiable attempts to injure her or intimidate her had taken place, that other witnesses were available to support her claim that her life was being threatened, something more was required—either by way of further investigation or protection— than the statement that was made by one detective to Linda that she would have to be hurt before the police could do anything for her. [***]

More significant, however, is the fundamental flaw in the reasoning behind the argument alleging judicial interference. It is a complete oversimplification of the problem of municipal tort liability. What it ignores is the fact that indirectly courts are reviewing administrative practices in almost every tort case against the State or a municipality, including even decisions of the Police Commissioner.

The truth of the matter, however, is that the courts are not making policy decisions for public officials. In all these municipal negligence cases, the courts are doing two things. First, they apply the principles of vicarious liability to the operations of government. Courts would not insulate the city from liability for the ordinary negligence of members of the highway department. There is no basis for treating the members of the police department differently. Second, and most important, to the extent that the injury results from the failure to allocate sufficient funds and resources to meet a minimum standard of public administration, public officials are presented with two alternatives: either improve public administration or accept the cost of compensating injured persons. Thus, if we were to hold the city liable here for the negligence of the police, courts would no more be interfering with the operations of the police department than they “meddle” in the affairs of the highway department when they hold the

municipality liable for personal injuries resulting from defective sidewalks, or a private employer for the negligence of his employees. In other words, all the courts do in these municipal negligence cases is require officials to weigh the consequences of their decisions. If Linda Riss' injury resulted from the failure of the city to pay sufficient salaries to attract qualified and sufficient personnel, the full cost of that choice should become acknowledged in the same way as it has in other areas of municipal tort liability. Perhaps officials will find it less costly to choose the alternative of paying damages than changing their existing practices. That may be well and good, but the price for the refusal to provide for an adequate police force should not be borne by Linda Riss and all the other innocent victims of such decisions.

What has existed until now is that the City of New York and other municipalities have been able to engage in a sort of false *590 bookkeeping in which the real costs of inadequate or incompetent police protection have been hidden by charging the expenditures to the individuals who have sustained often catastrophic losses rather than to the community where it belongs, because the latter had the power to prevent the losses.

Although in modern times the compensatory nature of tort law has generally been the one most emphasized, one of its most important functions has been and is its normative aspect. It sets forth standards of conduct which ought to be followed. The penalty for failing to do so is to pay pecuniary damages. At one time the government was completely immunized from this salutary control. This is much less so now, and the imposition of liability has had healthy side effects. In many areas, it has resulted in the adoption of better and more considered procedures just as workmen's compensation resulted in improved industrial safety practices. To visit liability upon the city here will no doubt have similar constructive effects. No "presumed cure" for the problem of crime is being "foisted" upon the city as the majority opinion charges. The methods of dealing with the problem of crime are left completely to the city's discretion. All that the courts can do is make sure that the costs of the city's and its employees' mistakes are placed where they properly belong. Thus, every reason used to sustain the rule that there is no duty to offer police protection to any individual turns out on close analysis to be of little substance.

The rule is judge made and can be judicially modified. By statute, the judicially created doctrine of "sovereign immunity" was destroyed. It was an unrighteous doctrine, carrying as it did the connotation that the government is above the law. Likewise, the law should be purged of all new evasions, which seek to avoid the full implications of the repeal of sovereign immunity. No doubt in the future we shall have to draw limitations just as we have done in the area of private litigation, and no doubt some of these limitations will be unique to municipal liability *593 because the problems will not have any counterpart in private tort law. But if the lines are to be drawn, let them be delineated on candid considerations of policy and fairness and not on the fictions or relics of the doctrine of "sovereign immunity". Before reaching such questions, however, we must resolve the fundamental issue raised here and recognize that, having undertaken to provide professional police and fire protection, municipalities cannot escape liability for damages caused by their failure to do even a minimally adequate job of it.

The Appellate Division did not adopt the "no duty" theory, but said there was no negligence here because the danger was not imminent. Despite the fact that the majority of the Appellate Division "agree[d] that certain rulings, and particularly the manner in which they were made, did not add to the appearance of a fair trial", and which, in fact, resulted in a wholly inadequate hearing, the majority

found that the “facts brought out on this trial do not show the presence of such imminent danger that extraordinary police activity was so indicated that the failure to take it can be deemed unreasonable conduct.” This finding does not stand examination and to its credit the city does not argue that this record would not support a finding of negligence. The danger to Linda was indeed imminent, and this fact could easily have been confirmed had there been competent police work.

Moreover, since this is an appeal from a dismissal of the complaint, we must give the plaintiff the benefit of every favorable inference. The Appellate Division’s conclusion could only have been reached by ignoring the thrust of the plaintiff’s claim and the evidence in the record. A few examples of the actions of the police should suffice to show the true state of the record.

Linda Riss received a telephone call from a person who warned Linda that Pugach was arranging to have her beaten up. A detective learned the identity of the caller. He offered to arrest the caller, but plaintiff rejected that suggestion for the obvious reason that the informant was trying to help Linda. When Linda requested that Pugach be arrested, the detective said he could not do that because she had not yet been hurt. The statement was not so. It was and is a crime to conspire to injure someone. True there was no basis to arrest Pugach then, but that was only because the necessary leg work had not been done. No one *594 went to speak to the informant, who might have furnished additional leads. Linda claimed to be receiving telephone calls almost every day. These calls could have been monitored for a few days to obtain evidence against Pugach. Any number of reasonable alternatives presented themselves. A case against Pugach could have been developed which would have at least put him away for awhile or altered the situation entirely. But, if necessary, some police protection should have been afforded.

Perhaps, on a fuller record after a true trial on the merits, the city’s position will not appear so damaging as it does now. But with actual notice of danger and ample opportunity to confirm and take reasonable remedial steps, a jury could find that the persons involved acted unreasonably and negligently. Linda Riss is entitled to have a jury determine the issue of the city’s liability. This right should not be terminated by the adoption of a question-begging conclusion that there is no duty owed to her. The order of the Appellate Division should be reversed and a new trial granted.

Note 1. What does the court mean when it writes: “Quite distinguishable, of course, is the situation where the police authorities undertake responsibilities to particular members of the public and expose them, without adequate protection, to the risks which then materialize into actual losses”? Did Riss not suffer actual losses? What sorts of actions would constitute, in your view, an “undertaking” of “responsibilities to particular members of the public”?

Note 2. The dissent states that “No one is contending that the police must be at the scene of every potential crime or must provide a personal bodyguard to every person who walks into a police station and claims to have been threatened” (although after *Riss*, in fact, the NYPD did assign a full-time bodyguard to her). Instead, the dissent writes that the police “need only act as a reasonable man would under the circumstances. At first there would be a duty to inquire. If the inquiry indicates nothing to substantiate the alleged threat, the matter may be put aside and other matters attended to. If, however, the claims prove to have some basis, appropriate steps would be necessary.” What are the costs and benefits of applying a reasonableness standard to police protection? What are the implications of doing so, in terms of allocating decision authority between judge and jury, or in terms of the institutional competence of courts versus legislators? What do you think is the right answer, normatively, here?

Note 3. The facts of *Riss* are upsetting, whatever one feels about the normative propositions expressed in the two differing opinions. Pugach's violent assault and partially blinding Riss seems like a culmination of threats he had made, and they were part of a pattern of anger and retribution on behalf of a jilted lover. The facts point to deeper societal problems of sexism, controlling relationships and domestic violence, as well as to the law's sometimes-peripheral role in addressing these. The opinion does not address the psychological issues inherent in dynamics of harassment and control, such as those that are often involved in abusive relationships. In this case, the facts are a tragic testament to how deeply the psychological issues can run. This obituary from Riss's 2013 passing tells part of the story of her life with Pugach, whom she married *after* he was released from jail, and it opens with the following summary:

She was 22, a sheltered, dark-haired Bronx beauty said to look like Elizabeth Taylor. He was a decade older, a suave lawyer who courted her with flowers, rides in his powder-blue Cadillac and trips to glittering Manhattan nightclubs. He was married, though not to her. Before long, tiring of his unfulfilled promises to divorce his wife, she ended their affair. He hired three men, who threw lye in her face, blinding her, and went to prison for more than a decade. Afterward, she married him.

<https://www.nytimes.com/2013/01/24/nyregion/linda-riss-pugach-whose-life-was-ripped-from-headlines-dies-at-75.html>

This excerpt's conclusion hints at the unusual nature of Riss's 38-year marriage to Pugach but it was even more sensational and difficult for outsiders to understand. Their relationship, including many aspects of its abuse, was documented in a book and a documentary, *Crazy Love*, released in 2007. According to the New York Times, the documentary is “[p]art cautionary tale, part psychological study, part riveting disaster narrative.” It is difficult to watch but recommended for those interested in the dynamics of abusive relationships. It also implicates the New York Police Department once again but in a more surprising way. A female bodyguard was assigned to guard Riss after Pugach blinded her, and Riss and her guard became friends. When Pugach, from prison, decided to woo Riss again, he appealed to the bodyguard and she ultimately intervened to help Pugach court Riss (apparently quite in contravention of her employment mandate to protect Riss from him at all costs). After the couple reunited, however, Pugach eventually resumed his womanizing. The obituary describes a trial in 1997 during which Pugach was tried for charges of abuse and attempted murder of a *different* woman while married to Linda Riss (now “Mrs. Pugach”): “At the trial, at which Mr. Pugach represented himself, Mrs. Pugach testified on his behalf, telling him in open court, ‘You’re a wonderful, caring husband.’ The alleged victim in the case was Mr. Pugach’s mistress of five years.”

Does knowing about the abusive dynamic between Riss and Pugach lend support for one or the other of the opinions in *Riss*? Tort law has tended to keep its distance from domestic violence, historically treating spouses and domestic partners as presumptively immune from tort liability for harms they cause each other, partly out of longstanding concerns that courts are not the right entity to “interfere” with familial relations and could make problems worse. Scholarship has also long shown that the reluctance to use tort law to help victims of domestic violence reflects latent misogyny in the legal system. In your view, is this an area in which policy concerns ought to militate in favor of more or less regulation through tort law? What are the countervailing factors in your consideration?

Note 4. How far should discretion for police decisionmaking extend with respect to their assessments of threat and their allocation of resources to respond to given threats? How realistic or reasonable is it to anticipate that they will make these predictions accurately? How accurately does tort law, or should tort law, expect the police to make such predictions? The dissent talks about a strict liability standard; is this the likely outcome of holding the police liable when they make the wrong call?

Check Your Understanding (4-6)

Question 1. When the dissent in *Riss v. NYC* summarizes the majority's rule as saying, "Because we owe a duty to everybody, we owe it to nobody," he is making reference to which of the following:

An interactive H5P element has been excluded from this version of the text. You can view it online here: <https://saidtorts2d.lawbooks.cali.org/?p=72#h5p-104>

Chapter 24. Statutes of Limitation and Repose

Statutes of Limitation. Statutes of limitation are mandatory deadlines by which a plaintiff must bring a claim in a civil case or lose their ability to pursue it. In many, if not most torts cases, the statute of limitations is two or three years; the law of the forum determines the length. For certain narrow areas that involve long-term projects (like architecture and construction) or long-lasting harm (such as in latent chemical pollution cases), there may be longer prescribed periods of potential liability. In a number of jurisdictions, defamation actions have a one-year limit.

In some cases, parties try to present their claim in whichever of the available windows is longer. Courts do not permit parties to frame their claims strategically so as to avoid the expiration of the statute of limitations. Although this topic is often an add-on at best in many law school classes, it is worth highlighting that it is likely legal malpractice for lawyers not to know the statutes of limitations or indeed, to practice in a way that causes a client to lose the ability to pursue their claim due to missing the deadline imposed by statute.

The “clock” starts running, typically, from the time when the claim accrued, that is, from the first possible time when the plaintiff *could* file suit and obtain relief. In tort law, this is usually **the date of tortiously caused injury**. However, in some instances, a plaintiff’s injury predates their awareness of injury. For example, this could happen when the plaintiff is defamed without their initially being aware of it and later suffers professionally or personally, only then discovering the existence of an earlier defamatory statement that has caused harm. Similarly, a plaintiff may be exposed to some sort of harm or defective design that exerts harmful effects which take some time to become discernible or whose cause has not previously been traced to the tortfeasor. In cases such as these, where the injury is latent or unknown, the claim accrues from **the date of discovery rather than injury**. This extension of the start of the statute of limitations is known as **the discovery rule** and students will encounter it again in property law later in their first year.

The expiration of the statute of limitations is usually raised by the defendant as a defense to the lawsuit. However, the statute may be “tolled,” or paused, for minors or those incapable of bringing a claim for reasons of incompetence or disability. In some instances, parties may be estopped from using the expiration of the statute of limitations as a defense if they have engaged in behaviors like fraud or deceit that caused the plaintiff to delay bringing a lawsuit.

Statutes of limitation are generally considered to impose procedural limits. A claim will be dismissed as time-barred if it falls outside the statute of limitations by even a single day, regardless of the substantive merits of the claim. The central purpose of these statutes is to incentivize prompt action by the plaintiff; effectively, they start a legislative timer running. In that sense, these statutes are forward-looking. They begin at some date in time (injury or discovery) and then fix a particular period in time.

Statutes of Repose. By contrast, statutes of repose are typically considered to be substantive rather than procedural, and they are aimed less at incentivizing the plaintiff than protecting the defendant. Statutes of repose create an outer limit on the right to bring a civil action. This limit is not measured from the date on which the claim accrues but instead from the date of the last culpable act or omission of the defendant. A statute of repose bars any suit that is brought after a specified time from the defendant’s last action. In torts, that could mean negligently designing or manufacturing a product, or

continuing to sell copies of a book that contains defamatory language. The repose will bar a lawsuit even if the period ends before the plaintiff has discovered an injury. In fact, it will bar a lawsuit even if the plaintiff has not yet been injured and later sustains an injury. Effectively, a statute of repose creates a sharp break for the defendant, a fresh start or point at which they can be clear that they are no longer potentially liable in connection with some action or venture. Without such a statute, for instance, a contractor who builds a building could find themselves sued two or three decades after building it as the result of a latent defect's becoming known.

Statutes of repose exist to protect against risks of infinite liability and to ensure some predictability for potential defendants. Such statutes are retrospective in the sense they look back to the last action by the defendant to measure potential claims' validity. The interest in giving "repose" or peace of mind to the defendant is so strong that unlike statutes of limitations, statutes of repose are not usually tolled for equitable considerations (such as age or incompetence). Because they are somewhat more rigid and potentially harsher for plaintiffs, statutes of repose are less commonly used. They also tend to be longer. For instance, the statute of repose for construction-based claims tends to be ten years long. Statutes of repose can be a very helpful policy tool, however, in areas such as medical malpractice, products liability or construction in which industry or policy-makers fear the chilling effects of potentially endless liability.

Comparing the two types of statutes, their names are a helpful starting point. Statutes of limitation are aimed at *limiting the plaintiff* and statutes of repose are aimed at giving the defendant peace of mind, or providing the *reassurance of "repose."* Sometimes the two operate together as in the following example.

Example: A Statute of Limitations and Repose

In Illinois, **a statute of limitations** mandates that an owner wishing to bring a lawsuit for a construction defect do so **within four years** of actual or constructive notice of the defect. 735 ILCS 5/13-214 (a). **A statute of repose** cuts off the period of potential discovery, however: "No action based upon tort, contract or otherwise may be brought against any person for an act or omission of such person in the design, planning, supervision, observation or management of construction, or construction of an improvement to real property **after 10 years** have elapsed from the time of such act or omission." 735 ILCS 5/13-214 (b). This means that the owner has **up to ten years** from the date of substantial completion of the construction within which to *discover* the defect and **another four years** during which 214(a)'s limitation period runs, or effectively, **up to fourteen years** maximum from the defendant's last actions.

There are four limits or exceptions imposed. If the builder voluntarily provides a longer warranty or engages in fraudulent misrepresentations, these limitations on the timeliness of available actions will be disregarded under express provisions set out at 214(d) and (e) respectively. In addition, the limitation and repose provisions are both tolled for disability or youth: "If a person otherwise entitled to bring an action could not have brought such action within the limitation periods herein solely because such person was under the age of 18 years, or a person with a developmental disability or a person with mental illness, then the limitation periods herein shall not begin to run until

the person attains the age of 18 years, or the disability is removed.” 735 ILCS 5/13-214 (c).

Lastly, the legislature expressly excepted asbestos cases. Under 214(f), the statute of repose “does not apply to an action that is based on personal injury, disability, disease, or death resulting from the discharge into the environment of asbestos.” Asbestos use was common in construction and insulation and thus often implicated in construction injuries. It is now subject to several restrictions and partial bans given the conclusive evidence that it causes several kinds of cancer. Listing asbestos as an exception here creates the strong incentive for builders to take preventive measures in all matters related to asbestos. It also comports with Illinois legislation and regulation by the Illinois Environmental Protection Agency, which have issued specific rules about asbestos.

In conclusion, there are overlapping policy interests in the two forms of statutory limits and legislatures sometimes expressly connect them as the Illinois example above illustrates. In general, the two types of limits on causes of action in tort law can be distinguished and must be separately taken into account whenever they are both relevant.

Exam Tip: A statute of limitations governs the time within which a suit may be brought once a cause of action accrues (whether from injury or discovery). A statute of repose limits the time within which an action may be brought regardless of the accrual of a cause of action—this means a cause of action can be barred under a statute of repose even before it has accrued! Be sure to look for both kinds of limits!

Recall that statutes of limitation are procedural and forward-looking, aimed at the plaintiff; statutes of repose are substantive and retrospective, aimed primarily at the defendant. When issue-spotting, look at the plaintiff’s conduct to assess whether they’ve complied with the statute of limitations. If there is mention of a statute of repose, look at the date of defendant’s last known conduct to see whether the claim is barred.

Perkins v. HEA of Iowa, Inc., Supreme Court of Iowa (2002) (651 N.W.2d 40)

Diane Perkins contracted hepatitis C as a result of her employment at HEA of Iowa, a retirement facility in Clinton. An arbitrator awarded her workers’ compensation benefits, but the award was vacated by the acting industrial commissioner. On judicial review, the award was reinstated by the district court, which ruled that the commissioner’s findings, with respect to the application of our discovery rule, were not supported by substantial evidence. The employer appealed. The court of appeals, on a divided vote, affirmed. We granted the employer’s application for further review. We affirm the decision of the court of appeals and the judgment of the district court.

The industrial commissioner found the following facts. On October 2, 1990, a patient at HEA had a shunt in his leg used for attaching a dialysis catheter. The shunt was pulsating and leaking blood. The

charge nurse directed Perkins to take the patient's vital signs and to re-dress the shunt wound. Part of Perkins' job was to listen for "bruits" (or unusual noises). As Perkins leaned over the patient's leg to listen for bruits near the shunt, the leg ruptured. The entire room was sprayed with blood. Perkins had blood all over her body and in her mouth, eyes, and ears.

The patient was infected with hepatitis C, a fact not known to Perkins prior to the rupture. Perkins testified she did not even know what hepatitis C was at that time. A written report of the incident was made, and Perkins was informed by the director of nursing at HEA that, because the patient had hepatitis C, Perkins needed to be tested. A letter in evidence from HEA to its insurance carrier regarding this event described the protocol for testing for hepatitis C infection. The tests should be conducted shortly after possible exposure in order to determine whether the exposed person had been previously infected. Six months later a second test should be performed to determine if the disease had actually been contracted. A third test is recommended at one year after exposure. Perkins was tested on October 11, 1990, shortly after the event, and the test results were negative. The testing physician recommended that she be retested six months after her exposure. However, no other testing was done until late 1995 when Perkins had pneumonia or early 1996 when she was seen at the University of Iowa Hospitals and Clinics. Through these tests, Perkins was found to have abnormal liver function, but she was *43 not actually diagnosed with hepatitis C until April 1996.

Perkins filed a workers' compensation claim in October 1996. HEA defended on the grounds that this was an occupational disease under Iowa Code chapter 85A (1995), and her claim was barred by the one-year statute of repose under section 85A.12. In the alternative, HEA claimed, if this was an "injury" under Iowa Code chapter 85, it was barred by the two-year statute of limitations of section 85.26(1). Perkins responded that this event did not result in an occupational disease under chapter 85A, and as to the statute of limitations under chapter 85, her injury had not been discovered until 1995 or 1996. Under our discovery rule, she claims, her application for benefits was timely.

Our review of an industrial commissioner's decision is on error, not de novo. We, like the district court, are bound by factual findings made by the commissioner so long as those findings enjoy substantial support in the record made before the agency. [***] The industrial commissioner found that Perkins was put on "inquiry notice" at the time she was advised of the seriousness of hepatitis C exposure and the necessity of further testing. While the focus of the industrial commissioner and the reviewing courts has been on the application of the discovery doctrine, we must first focus on the employer's claim that this was an occupational disease, not an industrial injury. If it was an occupational disease, Iowa Code section 85A.12 would indisputably defeat the claim because that section is a statute of repose, not a statute of limitation. Therefore, the discovery rule would be inapplicable to save the plaintiff's case. [***] We therefore address the question of whether this was an occupational disease or an industrial injury.

III. The Occupational Disease Argument.

The statutory definition describes an occupational disease in terms of a worker's "exposure" to conditions in the workplace. [***] The term "exposure" indicates a passive relationship between the worker and his work environment rather than an event or occurrence or series of occurrences, which constitute injury under the Workers' Compensation Act. [c]

We have said:

[A]n “injury” is distinguished from a “disease” by virtue of the fact that an injury has its origin in a specific identifiable trauma or physical occurrence or, in the case of repetitive trauma, a series of such occurrences. A disease, on the other hand, originates from a source that is neither traumatic nor physical. [c]

It is significant in determining whether Perkins suffered an occupational disease, or an injury under workers’ compensation, that Perkins’ infection was linked to a sudden, specific incident of exposure.

The contraction of disease is deemed an injury by accident in most states if due to some unexpected or unusual event or *44 exposure. Thus, infectious disease may be held accidental if the germs gain entrance through a scratch or through unexpected or abnormal exposure to infection. 3 Larson’s Workmen’s Compensation Law § 51, at 51-1 (2002).

[***]

We agree with the industrial commissioner, the district court, and the court of appeals that this was an “injury” under the workers’ compensation provisions of Iowa Code chapter 85, not an “occupational disease” under chapter 85A. The issue still to be resolved is the application of the statute of limitations and the discovery rule.

Under Iowa Code section 85.26(1),

[a]n original proceeding for benefits under this chapter or chapter 85A ... shall not be maintained in any contested case unless the proceeding is commenced within two years from the date of the occurrence of the injury for which benefits are claimed....

This two-year statute of limitations is tempered by our “discovery” rule, which tolls the running of the statute until the injury is or should have been discovered. [c] The application of the discovery rule in personal injury and workers’ compensation cases has spawned considerable litigation in this court. The key issue has been: What did the claimant know concerning the elements of her claim, and when did she know it? The issue turns on whether Perkins was sufficiently on notice of an injury so as to have a duty to investigate further, under the reasonable-diligence standard, by arranging to be tested again after six months and one year from her exposure. This notice of the need to investigate has been referred to as “inquiry notice.” [c]

Knowledge is imputed to a claimant when he gains information sufficient to alert a reasonable person of the need to investigate. As of that date he is on inquiry notice of all facts that would have been disclosed by a reasonably diligent investigation. [c] The industrial commissioner found that the statute of limitations, Iowa Code § 85.26(1), barred Perkins’ claim because she was on inquiry notice of the key elements of her claim immediately upon her exposure to the patient’s blood.

[***] [T]he two-year limitation period begins to run when “the employee discover[s] or in the exercise of reasonable diligence should ... discover [] the nature, seriousness and probable compensable character” of his injury or disease. [c] We have held that a claimant must have knowledge, either actual or implied, of all three characteristics of the injury before the statute begins to run. ...

In *Ranney* the claimant was exposed to toxic paint solvents in his job from 1975 to 1981. In 1985 he was diagnosed with Hodgkin’s disease. Following his diagnosis, he inquired of several doctors about

a possible connection between his exposure to the chemicals and his disease. In 1987 or 1988 his wife was a law student, and she discussed with Ranney the possibility of a connection between the exposure to chemicals and his health condition. [c] In 1991 Ranney asked a treating doctor about a connection, and the doctor confirmed a link between the job and his injury. Ranney filed his workers' compensation case in 1991 and relied on the discovery rule to avoid the application of the statute of limitations.

We rejected Ranney's claim that inquiry notice did not apply to his case because he suffered from a latent injury. We said:

When Ranney was diagnosed with Hodgkin's disease in 1985, his condition was no longer latent; it was then known. At that point, Ranney was subject to the same duty to investigate as is any other plaintiff who knows he has sustained an injury. *Id.* at 154. We also rejected Ranney's argument that he could not be charged with inquiry notice unless he was aware of the probable connection between his injury and his employment. We think that once a claimant knows or should know that his condition is possibly compensable, he has the duty to investigate. The purpose of the investigation is to ascertain whether the known condition is probably, as opposed to merely possibly, compensable. *Ranney*, 582 N.W.2d at 155 (citations omitted). [***]

In *LeBeau v. Dimig*, 446 N.W.2d 800 (Iowa 1989), the plaintiff was injured in an automobile accident on November 12, 1983. She made a claim for minor head injuries and was paid by the other driver, Dimig. In August 1985 LeBeau was diagnosed as having epilepsy. On July 31, 1987, she sued Dimig, claiming the epilepsy was caused by the 1983 accident. *LeBeau*, 446 N.W.2d at 801. The defendant raised the two-year statute of limitations under Iowa Code section 614.1(2). The plaintiff resisted a motion for summary judgment based on that defense by claiming she did not know, until 1985, that she had epilepsy. We said:

The issue raised in this appeal, however, is apparently one of first impression: When an accident occurs causing minor injuries and later more serious injuries appear, does the plaintiff's cause of action "accrue" for statute of limitations purposes at the time of the first injury; at the time of the later manifestation of another injury; or are there two time periods, one commencing with the first injury and the other upon discovery of the second injury? *Id.* at 801-02. We characterized this as a "traumatic event/latent manifestation" case, or one in which the plaintiff has sustained both immediate and latent injuries caused by a noticeable, traumatic occurrence. At the time of the traumatic event, the plaintiff realizes both that he is injured and what is responsible for causing the injury. The full extent of the harm, however, has not become manifested. *Id.* at 802 [c].

Although we characterized LeBeau's argument as "compelling," we rejected it because her theory would allow splitting of a cause of action, resulting in the application of different statutes of limitation and inserting uncertainty into the resolution of such cases. [c] In *LeBeau* we held the plaintiff's initial complaint of a minor injury and her collection of a relatively small settlement (\$200) evidenced sufficient awareness of her injury to subject her claim to the two-year statute of limitations. *Id.* at 803. This "seriousness" component of inquiry notice, [c], is not triggered by "every minor ache, pain, or symptom" as we have noted. [cc] Therefore, the failure to file a claim within two years of the occurrence of the injury may be excused if the claimant had no reason to believe the condition was

serious. If the injury is trivial or minor, or the symptoms indicate no serious problem, the seriousness component is not met. [c]

The industrial commissioner in assessing the discovery issue stated:

Claimant knew shortly after the incident at the nursing home that she had been *exposed* to hepatitis C. She was tested, and informed of the seriousness of the disease or condition [which she did not yet have]. She was counseled to return for further testing in six to twelve months for a final determination regarding her status. She was fully informed of the need for the testing, and underwent the initial tests. Claimant did not *47 follow-up with the medical care providers to undergo the later testing. Claimant knew of the *possibility* that she contracted hepatitis C at the time she took the initial test, October 11, 1990. As of October 11, 1990, she had been informed that the patient had hepatitis C. Based on the evidence, it cannot be determined that claimant was unaware of the seriousness of her condition, and that the condition was work-related. Claimant failed to file her petition within two years after the date of the injury, which was October 2, 1990. As a result, she takes nothing from these proceedings. (Emphasis added.)

None of our cases, and none of those cited by the HEA or the industrial commissioner, have applied the rule of law announced in the commissioner's ruling, *i.e.*, that *exposure* to a disease triggers a duty to inquire further. In all of the Iowa cases discussed in this opinion, the claimant knew he or she was injured, not merely exposed to injury, before the duty to inquire arose. In some cases the claimant did not know how serious the injury was or whether it was work-related, but in all of the cases the claimant knew he or she had suffered an injury before the statute of limitations began to run.

The Oklahoma Supreme Court, in another hepatitis C case, reached the same conclusion:

Mere exposure to an infectious disease, no matter how threatening, is not enough to constitute a compensable event—it is not “accidental injury.” An on-the-job exposure must pass through the incubation period and develop into an infectious disease *before* it may be viewed as an accidental injury compensable by the employer. An employer's apprehension of an employee's exposure to a disease, even when followed by the act of administering prophylactic vaccination, cannot be translated into compensation liability for an “accidental personal injury.” [c]

If there is anything clear in this record with respect to the “condition” to which the commissioner referred, it is that as of the time Perkins is charged with inquiry notice she had not been injured. She had been exposed through a traumatic and frightening event, but she was not injured. If, as we have said, inquiry notice does not arise from “every minor ache, pain, or symptom,” [c], inquiry notice surely cannot be triggered when there is *no* ache, pain, or symptom of an injury. [***] Our workers' compensation law does not provide a remedy for a person who has merely been exposed to injury.

We hold the date of injury was the date Perkins discovered she had hepatitis C, April 20, 1996, the date it was diagnosed. It did not commence from the date she was exposed to it. The industrial commissioner's application of a contrary rule in this case is “affected by other error of law,” Iowa Code § 17A.19(8)(e), and must be reversed. We therefore affirm, although on different grounds, both the ruling of the court of appeals and the judgment of the district court.

Note 1. The court states that it affirms, “although on different grounds,” the lower court’s rulings. On what grounds does this court affirm and what are the grounds on which the lower courts ruled?

Note 2. What is the knowledge standard required under the discovery rule? What policy concerns do you suspect are likely to underlie this choice of standard?

Note 3. Why do you think the court refrains from finding that “exposure to a disease triggers a duty to inquire further”? When does this court suggest a “duty to investigate” may arise?

Note 4. Statutes of Limitation and Repose serve multiple important functions as you see in *Perkins*. However, they impose costs on certain stakeholders and the system overall, as well. What doctrines do you imagine might they complicate? What purposes might they frustrate? What solutions do you imagine courts could undertake to balance out or minimize the tensions among these competing purposes? Should legislatures be involved?

MODULE 5. PRODUCTS LIABILITY LAW

Chapter 25. Developments in Tort Law and Early Products Liability Law

Thomas v. Winchester, Court of Appeals of New York (1852) (6 N.Y. 397)

This is an action brought to recover damages from the defendant for negligently putting up, labeling and selling as and for the extract of *dandelion*, which is a simple and harmless medicine, a jar of the extract of *belladonna*, which is a deadly poison. [***] The plaintiff Mary Ann Thomas, [***] being in ill health, her physician prescribed for her a dose of dandelion. Her husband purchased what was believed to be the medicine prescribed, at the store of Dr. Foord, a physician and druggist in Cazenovia, Madison county, where the plaintiffs reside.

A small quantity of the medicine thus purchased was administered to Mrs. Thomas, on whom it produced very alarming effects; such as coldness of the surface and extremities, feebleness of circulation, spasms of the muscles, giddiness of the head, dilation of the pupils of the eyes, and derangement of mind. She recovered however, after some time, from its effects, although for a short time her life was thought to be in great danger.

The medicine administered was *belladonna*, and not *dandelion*. The jar from which it was taken was labeled “1/2 lb. *dandelion*, prepared by A. Gilbert, No. 108, John-street, N. Y. Jar 8 oz.” [***]

[Defendant Winchester manufactured, purchased and sold “certain vegetable extracts for medicinal purposes.” He hired “A. Gilbert” as an assistant and they used Gilbert’s name on the labels because that increased sales. The mislabeled extract in Mrs. Thomas’ jar was manufactured by another manufacturer or dealer, not Winchester, sold to Aspinwall with Gilbert’s label on it, and then sold it Foord who, believing it was accurately labeled, sold it to Mrs. Thomas.]

The extract of dandelion and the extract of belladonna resemble each other in color, consistence, smell and taste; but may on careful examination be distinguished the one from the other by those who are well acquainted with these articles.

[***] The case depends on [***] whether the defendant, being a remote vendor of the medicine, and there being no privity or connection between him and the plaintiffs, the action can be maintained.

If, in labeling a poisonous drug with the name of a harmless medicine, for public market, no duty was violated by the defendant, excepting that which he owed to Aspinwall, his immediate vendee, in virtue of his contract of sale, this action cannot *408 be maintained. If A. build a wagon and sell it to B., who sells it to C., and C. hires it to D., who in consequence of the gross negligence of A. in building the wagon is overturned and injured, D. cannot recover damages against A., the builder. A.’s obligation to build the wagon faithfully, arises solely out of his contract with B. The public have nothing to do with it. Misfortune to third persons, not parties to the contract, would not be a natural and necessary consequence of the builder’s negligence; and such negligence is not an act imminently dangerous to human life.

So, for the same reason, if a horse be defectively shod by a smith, and a person hiring the horse from the owner is thrown and injured in consequence of the smith's negligence in shoeing; the smith is not liable for the injury. The smith's duty in such case grows exclusively out of his contract with the owner of the horse; it was a duty which the smith owed to him alone, and to no one else. And although the injury to the rider may have happened in consequence of the negligence of the smith, the latter was not bound, either by his contract or by any considerations of public policy or safety, to respond for his breach of duty to any one except the person he contracted with

But the case in hand stands on a different ground. The defendant *409 a dealer in poisonous drugs. Gilbert was his agent in preparing them for market. The death or great bodily harm of some person was the natural and almost inevitable consequence of the sale of belladonna by means of the false label. Gilbert, the defendant's agent, would have been punishable for manslaughter if Mrs. Thomas had died in consequence of taking the falsely labeled medicine. Every man who, by his culpable negligence, causes the death of another, although without intent to kill, is guilty of manslaughter. (2 R. S. 662, § 19.) [***] And this rule applies not only where the death of one is occasioned by the negligent act of another, but where it is caused by the negligent omission of a duty of that other. [c] Although the defendant Winchester may not be answerable criminally for the negligence of his agent, there can be no doubt of his liability in a civil action, in which the act of the agent is to be regarded as the act of the principal.

In respect to the wrongful and criminal character of the negligence complained of, this case differs widely from those put by the defendant's counsel. No such imminent danger existed in those cases. In the present case the sale of the poisonous article was made to a dealer in drugs, and not to a consumer. The injury therefore was not likely to fall on him, or on his vendee who was also a dealer; but much more likely to be visited on a remote purchaser, as actually happened. The defendant's negligence put human life in imminent danger. Can it be said that there was no duty on the part of the defendant, to avoid the creation of that danger by the exercise of greater caution? or that the exercise of that caution was a duty only to his immediate *410 vendee, whose life was not endangered? The defendant's duty arose out of the nature of his business and the danger to others incident to its mismanagement. Nothing but mischief like that which actually happened could have been expected from sending the poison falsely labeled into the market; and the defendant is justly responsible for the probable consequences of the act.

The duty of exercising caution in this respect did not arise out of the defendant's contract of sale to Aspinwall. The wrong done by the defendant was in putting the poison, mislabeled, into the hands of Aspinwall as an article of merchandise to be sold and afterwards used as the extract of dandelion, by some person then unknown. [***] The defendant's contract of sale to Aspinwall does not excuse the wrong done to the plaintiffs. It was a part of the means by which the wrong was effected. The plaintiffs' injury and their remedy would have stood on the same principle, if the defendant had given the belladonna to Dr. Foord without price, or if he had put it in his shop without his knowledge, under circumstances which would probably have led to its sale on the faith of the label. [***]

The defendant, by affixing the label to the jar, represented its contents to be dandelion; and to have been "prepared" by his agent Gilbert. The word 'prepared' on the label, must be understood to mean that the article was manufactured by him, or that it had passed through some process under his hands, which would give him personal knowledge of its true name and quality.

[***] [T]he defendant cannot, in this case, set up as a defense, that Foord sold the contents of the jar as and for what the defendant represented it to be. The label conveyed the idea distinctly to Foord that the contents of the jar was the extract of dandelion; and that the defendant knew it to be such. So far as the defendant is concerned, Foord was under no obligation to test the truth of the representation. [***]

GARDINER, J. concurred in affirming the judgment, on the ground that selling the belladonna without a label indicating that it was a *poison*, was declared a misdemeanor by statute; (2 R. S. 694, § 23;) but expressed no opinion upon the question whether, independent of the statute, the defendant would have been liable to these plaintiffs.

412** [] Judgment affirmed.

Note 1. Why might the case previously have depended on the fact that Thomas bought the medicine from “a remote vendor”? Why does this court determine that it does not?

Note 2. How does the court distinguish precedents to the contrary offered by the defendant?

Note 3. How would you articulate the breach of due care and the scope of the duty defendant owed Mrs. Thomas? Might it have been reasonable to inquire whether Foord also had a duty, and if so, what the scope of that duty might have required?

Note 4. Is Winchester *effectively* being held strictly liable for Mrs. Thomas’ injuries even though the court refers to it as negligence? Why or why not?

Note 5. What was the significance of Gilbert’s having prepared and labeled the extract?

The Progressive-Era Rise of the First Consumer Protection Laws

Before the advent of contemporary products liability law, consumers often found that courts did not meaningfully enable them to recover in tort law from injuries suffered as a result of the actions of manufacturers, distributors and vendors of food, drugs and other products including automobiles. Consumer protection and products liability law are both a product of the 20th century, and their precursors were actions in tort law suing for injury or wrongful death. However, the plaintiff often faced hurdles that could prove insurmountable such as the requirement of a contract or privity to ground a duty, as well as difficulties asserting what happened and what fault, if any, had led to their injuries. The increasing complexity of manufacturing made injuries more frequent but also more remote and out of view from the consumer’s perspective. The increasing attenuation of the product supply chain also meant more intermediaries between the manufacturer (along with its sub-manufacturers, potentially) and the ultimate user of the product. These factors put increasing social and legal pressure on the legal system.

Around the turn of the century, the cause of consumer welfare gained national momentum, especially with respect to food manufacturing and service. Individual states had begun promulgating laws to safeguard the purity and safety of foods. Now the attention was trained on the federal level. The push for federal legislation came partly in connection with the efforts of the so-called “muckrakers.” These were journalists and writers dedicated to improving the lot of workers and the poor; ending child labor;

and exposing corporate and governmental corruption. Progressive reformers had been lobbying for consumer protection legislation since the 1880s, and over 100 bills had been considered and rejected before one was finally adopted.

In 1905, a sensationalist and melodramatic piece of fiction was published which incorporated extensive research and reporting on the meat-packing industry. Upton Sinclair's novel, *The Jungle* (1905) disseminated vivid accounts of shockingly bad conditions in meat processing and manufacturing plants. The novel has been credited with bringing the imminent legal transformation to its tipping point. ("[T]he nauseating condition[s] that Upton Sinclair captured in *The Jungle* was the final precipitating force behind both a meat inspection law and a comprehensive food and drug law." See <https://www.fda.gov/about-fda/changes-science-law-and-regulatory-authorities/part-i-1906-food-and-drugs-act-and-its-enforcement>). According to Dean Prosser in his seminal article on the collapse of privity as a restrictive requirement in tort law, *The Jungle*

was the best selling book of the year, was translated into seventeen languages, and by 1922 had sold 150,000 copies. Intended as a piece of propaganda for socialism, *The Jungle* succeeded in becoming instead a minor *Uncle Tom's Cabin* of the war against bad food. The author said later that he had aimed at the public's heart, and by accident hit it in the stomach.

William L. Prosser, *The Assault Upon the Citadel (Strict Liability to the Consumer)*, 69 Yale L.J. 1099, 1105–06 (1960)

Whatever its possible faults as a literary work, *The Jungle* was a hit, and it may have played a galvanizing role in what would become the revolution transforming tort law from within. Sinclair's novel had depicted animals who were often sick or injured and being raised and slaughtered in a state of staggering filth. Workers in the novel were treated with about as much humanity as the animals; the meat packing industry was cast as ruthlessly exploitative of immigrants and other economically and legally vulnerable communities. During debates over the passage of potential food safety legislation, legislators heard horror stories of poisonous red dyes and other toxins being used casually throughout the food manufacturing industry. These stories built on Sinclair's damning account and helped to catalyze momentous reform.

The following year, President Theodore Roosevelt signed the Pure Food and Drug Act of 1906 and the Meat Inspection Act into law. In so doing, Roosevelt ushered in a new era of federal consumer protection and regulatory oversight of medicines, food, and meat. Various protections against medical quackery and deceptive advertising accompanied more stringent rules to ensure that food would henceforth be unadulterated. The Pure Food and Drug Act also paved the way for the creation of the Food and Drug Administration ("FDA") in 1930. From that time on, the FDA was the central source of regulation for substances ingested by humans (other than the Bureau of Alcohol, Tobacco, Firearms and Explosives, which was formed in 1972 and plays a rather different role).

In addition, Progressive-Era reforms led to the passage of the Federal Trade Commission Act in 1914, which created the eponymous independent agency charged with antitrust enforcement and consumer protection. Under the FTC Act,

[T]he Commission is empowered, among other things, to (a) prevent unfair methods of competition, and unfair or deceptive acts or practices in or affecting commerce; (b)

seek monetary redress and other relief for conduct injurious to consumers; (c) prescribe trade regulation rules defining with specificity acts or practices that are unfair or deceptive, and establishing requirements designed to prevent such acts or practices; (d) conduct investigations relating to the organization, business, practices, and management of entities engaged in commerce; and (e) make reports and legislative recommendations to Congress.

15 U.S.C. §§ 41-58, *as amended*.

Federal Regulation and the Slow Changes in State Tort Law

In retrospect, *Thomas v. Winchester* (the poison mislabeling case, *supra* at the start of Module 5), can be seen as a harbinger of the Progressive Era's profound changes to the legal landscape. *Thomas*' focus on labeling hints at the core concerns that would drive the progressive reform agenda for legal change: concerns related to consumer deception and injury to both consumers and workers. Put another way, progressive legal reforms promoted transparency, truth, safety and health. In their commitments to an increasingly robust set of protections for consumers and workers, however, these legislative changes did not always provide a right of action for injured consumers. Privity was also still a bar in cases in which there was no contract creating a duty between the parties.

Prior to these progressive reforms, consumers had had little protection against spoiled foods or injurious conditions. When diners at restaurants were injured by some non-food foreign object in their food, they were typically unable to recover for their injuries through tort law. Food purveyors could essentially ask "well, why didn't you look at your food more carefully?" In other words, *caveat emptor* ("buyer beware") was the default rule. Privity was a formidable hurdle and courts regularly declined to find for plaintiffs for various technical reasons. In point of fact, this hapless state of affairs continued for some time even *after* the Pure Food and Drug Act's passage in 1906.

For example, in *Ash v. Childs Dining Hall Co.*, 231 Mass. 86, (Mass. 1918) the presence of a black tack in a slice of blueberry pie served at a restaurant was not in itself evidence of negligence on the part of the defendant who had prepared the pie. The court held that *res ipsa loquitur* could not be applied and that there could be no liability without evidence of negligent conduct by the defendant whose breach of duty had caused the tack's presence in the pie. In *Chysky v. Drake Bros. Co.* (235 N.Y. 468, 1923), the plaintiff received a cake from her employer and suffered injuries from a nail contained in a slice of cake when she ate it. The court dismissed her claim due to lack of privity with the cake manufacturer since it was her employer who had purchased the cake. In *Redmond v. Borden's Farm Products Co.* (245 N.Y. 512, 1927), a court went the other way at first. The plaintiff, a fourteen month-old infant, had allegedly been injured by broken glass contained in a bottle of milk bought for her by her mother and distributed by the defendant. Glass passed into the infant's mouth and caused injuries while she was drinking the milk. The case was submitted to the jury and the verdict for the plaintiff was unanimously affirmed by the Appellate Division of the Supreme Court in the First Judicial Department (218 App. Div. 722, 1926). However, on appeal to the Court of Appeals, the case was reversed with no more than the following *per curiam* opinion: "Judgments reversed, and new trial granted, costs to abide event, on authority of *Chysky v. Drake Brothers Co.*, 235 N. Y. 468." In other words, the lack of privity in *Chysky* so obviously controlled this decision that no further opinion was

needed for reversal. If the fourteen month-old infant had bought her own milk and been injured drinking it, she *could have* recovered; that she was not a preternaturally precocious toddler able to do so appears to have been her legal case's fatal flaw. It is worth pointing out that tort law's omnipresent figure, Chief Justice Cardozo (as well as Justice Andrews, among others) concurred. *Redmond v. Borden's Farm Prod. Co.*, 245 N.Y. 512, 512, (1927).

Pure food legislation *had* improved the situation for consumers somewhat by creating a legal obligation on the part of manufacturers to safeguard their food products and to label them accurately. Recall tort law's purposes. The legislation served as a *deterrent* since manufacturers and distributors had to answer to the U.S. government if they fell out of compliance with the increasing regulations imposed for food safety. Balanced with businesses' profit motive, the new regulatory mandate created incentives to make safer food processing economically *efficient*. While these new laws protected consumers' food sources, they did nothing directly to *compensate* victims of negligence when accidents occurred. A rule that permitted recovery based on the technicality of privity, however, seemed antithetical to basic notions of *fairness* and *social justice*.

In negligence cases, recovery was still extremely limited and cases reflect formalistic, almost absurdly technical reasoning. Where consumers had a *contract* of some kind, or were in privity, they were owed a duty, and thus if the product they used or consumed was defective, recovery in tort might be allowed. Alternatively, if the defendant had intentionally hidden some defect and consumers lacked the ability to inspect goods for themselves or could not have discovered defects with their own ordinary inspection, the defendant would likely be liable in tort law for injuries their conduct caused. However, the theory of liability was fraud, not negligence, and it required a different fact pattern with a higher showing of culpability. It helped to disincentivize fraudulent concealment (which constitutes its own tort at common law) but did little to help curb negligent conduct.

Although *Thomas* had dispensed with the privity requirement in cases of mislabeling poisons, it was only binding authority in New York. Even there, its holding seemed to limit the scope of its rule to errors made with respect to labeling or representing a poison or other product carrying a high risk of danger with its use. It was unclear how expansively subsequent courts would interpret it. Over time, other courts did build on *Thomas*, thus forging the beginnings of contemporary products liability law. *See e.g. Schubert v. J. R. Clark Co.* 49 Minn. 331 (1892) (applying *Thomas* to find a manufacturer liable with respect to a defective ladder); *Devlin v. Smith* (89 N.Y. 470 (1882) (applying *Thomas* to hold liable the builder of a 90-foot scaffold for painters after it collapsed, killing the painter because the scaffold, like the poison, was an inherently dangerous product); *Torgesen v. Schultz*, 192 N.Y. 156, 157–58, 84 N.E. 956 (1908) (applying *Thomas* to find a jury question where plaintiff lost an eye due to the explosion of a bottle of carbonated water filled and put upon the market by the defendant).

Many of the early cases in what now is considered modern products liability law arose at the boundaries of tort and contract through the ideas of privity and warranty. They also often featured fact patterns with asymmetrical information, such as when manufacturers or retailers possessed the ability to inspect or confirm that a product was defect-free while the consumer lacked such an ability. Many cases arose in the areas of food preparation and processing, including canning and bottling. Get ready to read a lot of cases about Coca-Cola bottles (and consider why that is). Finally, this discussion may seem like it's revisiting ancient history not worth the time to delve into detail for the study of tort law in our era. However, the evolution of products liability law—its transformation at common law and through legislation, its expansion and subsequent contraction, its intense variation by state—provides an

excellent case study in common law. Rather than finding it maddening that the rule varies so much by jurisdiction, consider the reasons for which different jurisdictions developed in particular ways. The origins of product liability law left longlasting footprints in the common law that are worth understanding as a means of contextualizing current laws and gaining the capacity to anticipate future developments. In our era of rapidly changing technological advances, there will always be new questions for jurists to consider. Studying the ways in which courts have clung to rules or dispensed with them and their rationales provides a toolkit as well as a roadmap.

Sometimes when reading older cases, there is a tendency to dismiss their fact patterns as remote in time and thus improbable or utterly different from the present moment. Be wary of this tendency; often the facts remain salient in some way even despite social and technological changes. Take the meatpacking industry as an example. Clearly, many things have changed in the industry due to the major legislation of the 20th century and expansion of the agency powers that regulate the relevant entities. Notwithstanding those changes, a recent exposé of the industry featured an author with no experience who applied for a job and received one less than five hours later.

<https://www.theatlantic.com/magazine/archive/2021/07/meatpacking-plant-dodge-city/619011>

The author of the article, Michael Holtz, reported conditions that ought to remain concerning in light of the classification of meatpacking workers as “essential” employees who continued working throughout the COVID-19 pandemic. Many were sickened and some died in consequence of outbreaks at meatpacking plants.

Consider whether you think tort law should play a role in governing questions of worker health and safety at meatpacking plants. Who should determine whether eating industrially processed meat is important enough to risk workers’ safety? Who suffers if such meat does not remain available?

Our next case is one of the earliest torts cases nationally to establish a broader duty on the part of the defendant for injury arising from food even in the absence of privity and without the facts to sustain a fraud case. It introduces an influential theory of “implied warranty” with a rationale reminiscent of *Thomas*’ legal reasoning.

Chapter 26. Implied Warranty

Mazetti v. Armour & Co., Supreme Court of Washington (1913) (75 Wash. 622)

***623** The complaint alleges that the plaintiffs were operating a profitable restaurant in the city of Seattle, and dealing with the general public as their patrons; that defendant Armour & Co. is engaged in the business of manufacturing and selling to the public generally meats and products to be used as food; that it maintains a place of business in Seattle, Wash., from which it sells and distributes its goods, representing and holding out to the general public that its goods are pure, wholesome, and fit food for human beings; that on June 16, 1912, plaintiffs, in the usual course and conduct of their business, purchased from the Seattle Grocery Company a carton of cooked tongue, prepared and ready to be used for food without further cooking or labor; that such package had been manufactured and prepared by defendant Armour & Co.; that the carton or container bore its name, and that it was purchased to be sold to plaintiffs' customers; that in making such purchase plaintiffs relied upon the representations of Armour & Co. that said food was pure and wholesome and fit for food; that Armour & Co. were guilty of negligence in manufacturing and preparing the foods purchased, in that in the center of the carton was a foul, filthy, nauseating, and poisonous substance; that in the due course of trade plaintiffs served to one of their patrons a portion of the tongue; that the patron ate of it; that he then and there became sick and nauseated, and did then and there in the presence of other persons publicly expose and denounce the service to him of such foul and poisonous food; that the incident became known to the public generally; that plaintiffs had no knowledge or means of knowing the character of the food served; that its condition could not be discovered until it was served for use—all to the damage of the plaintiffs, etc., for loss of reputation, business, and lost profits during the life of their lease. Defendants demurred to the complaint. The demurrer of Armour & Co. was sustained, and plaintiffs have appealed.

***624** It has been accepted as a general rule that a manufacturer is not liable to any person other than his immediate vendee; that the action is necessarily one upon an implied or express warranty, and that without privity of contract no suit can be maintained; that each purchaser must resort to his immediate vendor. To this rule certain exceptions have been recognized: (1) Where the thing causing the injury is of a noxious or dangerous kind. (2) Where the defendant has been guilty of fraud or deceit in passing off the article. (3) Where the defendant has been negligent in some respect with reference to the sale or construction of a thing not imminently dangerous.

Within one of these exceptions is to be found the reason for holding the manufacturer of patent or proprietary medicines to answer at the suit of the ultimate consumer. Direct actions are allowed in such cases because the manufacturer of medicines is generally shrouded in mystery, and sometimes, if not generally, they contain poisons which may produce injurious results. They are prepared by the manufacturer for sale and distribution to the general public, and one purchasing them has a right to rely upon the implied obligation of the manufacturer that he will not use ingredients which if taken in prescribed doses will bring harmful results. Reference may be had to the following cases which sustain, and in which many other cases are cited which sustain, this exception: *Thomas v. Winchester*, 6 N. Y. 397; *Blood Balm Co. v. Cooper*, 83 Ga. 457; *Weiser v. Holzman*, 33 Wash. 87.

Another exception—the doctrine is comparatively recent—is referable [*sic*] to the modern method of preparing food for use by the consumer, and the more general and ever-increasing use of prepared food products. The following are among the more recent cases holding that the ultimate consumer may bring his action direct against the manufacturer: *625 [***] The contrary is held in the case of *Nelson v. Armour*, 76 Ark. 352. This case, though well reasoned along the lines of those causes which hold that the rule of *caveat emptor* applies, is not in touch with the modern drift of authority. Some of the cases hold that the action is for breach of warranty; others that it is to be sustained upon the ground of negligence. A few courts have attributed the growth of this exception to the general public policy as declared in the pure food laws [c], while others say that the liability for furnishing provisions which endanger human life rests upon the same grounds as the manufacturing of patent or proprietary medicine. [cc].

In the case of *Weiser v. Holzman*, this court said: ‘The rule does not rest upon any principle of contract, or contractual relation existing between the person delivering the article and the person injured, for there is no contract or contractual relation between them. It rests on the principle that the original act of delivering the article is wrongful, and that everyone is responsible for the natural consequences of his wrongful acts.’ Although the cases differ in their reasoning, all agree that there is a liability in such cases irrespective of any privity of contract in the sense of immediate contract between the *626 parties.

Indeed, we understand that respondent does not claim that the ultimate consumer, the person who ate the unfit food, would be denied a right of recovery under modern authority; but it is strenuously contended that such actions are sustained because the consumer has been injured in health and comfort, that the exception should not be carried to the extent of allowing a retailer of the goods to sue direct and recover for injury to his business and loss of reputation, that in such cases there must still be privity of contract. It seems that the test should not rest in finding the plaintiff’s damage in health or business, but in answering the question whether there has been a damage which may be justly attributed to the negligence or a breach of duty on the part of the one who had power and whose duty it was to prevent the wrong.

Counsel on either side have been zealous in searching the books, but only one case is submitted that goes directly to the right of the retailer or middleman to sue in the first instance—*Neiman v. Channellene Oil & Mfg. Co.*, 112 Minn. 13. The right to recover for loss of trade consequent upon the selling of impure food was sustained; the court saying, ‘A company which advertises itself as a manufacturer and seller of pure articles of food must be deemed to have knowledge of the contents of the articles offered for sale.’ The court held to the doctrine of implied warranty. The suit was brought by the retailer against his immediate vendor, so that we still have to meet the question of whether the retailer who has lost his trade can sue over the head of his immediate vendor, or join him with the manufacturer as in this case. In the light of modern conditions we see no reason why he should not. He has been damaged. He and all others who in the course of trade handled the unwholesome goods purchased them relying upon the name and reputation of the manufacturer. The goods were designed for ultimate consumption by an individual patron, and packed to facilitate *627 and make convenient such resales as might be made pending ultimate consumption.

Every tradesman, whether wholesaler or retailer, is in a sense a consumer, for he buys to resell. In a way he risks his reputation. He stakes it upon either an express warranty, as printed on the package, or an implied warranty that the goods are wholesome and fit for food. He is injured by the fault or a breach

of duty of the manufacturer, for his immediate vendor, like himself, has no way to test every sealed package. 'Remedies of injured consumers ought not to be made to depend upon the intricacies of the law of sales.' The obligation of the manufacturer should not be based alone on privity of contract. It should rest, as was once said, upon 'the demands of social justice.' *Ketterer v. Armour*, supra.

We may judicially recognize that the contents are sealed up, not open to the inspection or test, either of the retailer or of the customer, until they are opened for use, and not then susceptible to practical test, except the test of eating. When the manufacturer puts the goods upon the market in this form for sale and consumption, he, in effect, represents to each purchaser that the contents of the can are suited to the purpose for which it is sold, the same as if an express representation to that effect were imprinted upon a label. Under these circumstances, the fundamental condition upon which the common law doctrine of *caveat emptor* is based—that the buyer should 'look out for himself'—is conspicuously absent. *Tomlinson v. Armour*, supra, 75 N. J. Law, 748.

In *Pantaze v. West* (Ala. App.) 61 South. 42, the suit was brought against the retailer. In discussing the obligations of the retailer, the court treats him as a consumer within the law, saying: 'The fact was established without controversy that the defendant was the keeper of a public eating place, engaged in the business of serving food to his customers, the public, and, being thus engaged, and holding himself out as a public purveyor, he was bound to use due care to see that the foodstuffs served at his place of business to his customers were fit for human consumption, and could be partaken of without *628 causing sickness or endangering human life or health because of their unwholesome and deleterious condition, and, for any negligence in this particular in failing to observe this duty which proximately resulted in injury to one of the patrons of the place, the defendant would be responsible.'

Now, under all authority the immediate vendor would be liable upon one theory or another to the consumer. This being so, it should not be held that the vendor could not sue the manufacturer except to recoup against a judgment. He might thus be left without remedy. In denying the right to sue an immediate vendor, Spear, J., in *Bigelow v. Maine Central Ry. Co.*, 110 Me. 105, observed the wonderful discoveries of the past century and the amazing progress in perfecting known devices. He recalls the boast of the common law that it was able to adjust itself to the inevitable vicissitudes and changes that occur in the development of human affairs.

The principles of the common law have adapted themselves so aptly as to render almost imperceptible the radical transitions that have taken place. Of little less importance than the appearance of the great achievements referred to is the establishment and development of the canning industry in this country and in other parts of the world. It may be said that the art of canning, if not invented within the last century, has, at least, assumed the vast proportions which it has now attained within a comparatively few years. It involves a unique and peculiar method of distributing for domestic and foreign use almost every product known to the art of husbandry. The wholesaler, the retailer, and the user of these goods, whether in the capacity of caterer, seller, or host, sustain an entirely different duty, respecting a knowledge of their contents and quality, than prevails with regard to knowing the quality of those food products which are open to the inspection of the seller or victualer. With reference to these it may well be considered, as has been held, that, having an opportunity to investigate and thereby to know the quality of their merchandise, they are charged with a responsibility

amounting to a practical guaranty. The early rules of law were formulated upon the theory that *629 the provision dealer and the victualer, having an opportunity to observe and inspect the appearance and quality of the food products they offered to the public, were accordingly charged with knowledge of their imperfections. [cc] But, upon the state of facts in the case at bar, a situation arises that cannot in the practical conduct of the canning business fall within these rules. No knowledge of the original or present contents of a perfect appearing can is possible in the practical use of canned products. They cannot be chemically analyzed every time they are used. Accordingly, the reason for the rule having ceased, a new rule should be applied to the sale and use of canned goods that will more nearly harmonize with what is rational and just.

To the old rule that a manufacturer is not liable to third persons who have no contractual relations with him for negligence in the manufacture of an article should be added another exception, not one arbitrarily worked by the courts, but arising, as did the three to which we have heretofore alluded, from the changing conditions of society. An exception to a rule will be declared by courts when the case is not an isolated instance, but general in its character, and the existing rule does not square with justice. Under such circumstances a court will, if free from the restraint of some statute, declare a rule that will meet the full intendment of the law. No case has been cited that is squarely in point with the instant case; but there is enough in the adjudged cases to warrant us in our conclusion.

The facts stated in the complaint are admitted by demurrer. Plaintiffs have been injured. No other person or firm had an opportunity to check the offensive package after it was sealed and sent on its way. Right and reason demand that any party injured should have a right of recovery against the first offender without resorting to that circumlocution of action against intervening agents (a doubtful right at best, *Bigelow v. Maine Central*, supra), which is demanded where the product as well as the market *630 is open, and the rule of caveat emptor should in justice apply.

Plaintiffs' argument is also based on the pure food law. It is contended that the negligence of defendant is presumed if a violation of the pure food law be shown. This is admitted as a general proposition by defendant; but it says that the rule applies only where the statute was intended for the benefit of the party who brings the suit; that the pure food laws are intended for the benefit of the consumer alone. [***] The consumer purchases prepared food products to sustain life and health. The retailer purchases the same products, depending upon established brands to sustain his reputation as a dealer in clean and wholesome food. We would be disposed to hold on this question that, where sealed packages are put out, and it is made to appear that the fault, if any, is that of the manufacturer, the product was intended for the use of all those who handle it in trade as well as those who consume it. Our holding is that, in the absence of an express warranty of quality, a manufacturer of food products under modern conditions impliedly warrants his goods when dispensed in original packages, and that such warranty is available to all who may be damaged by reason of their use in the legitimate channels of trade.

We regard this case, in so far as the dealer is permitted to sue the manufacturer, as one of first impression. We think the complaint states a cause of action. If there is no authority for the remedy, 'it is high time for such an authority.' *Ketterer v. Armour*, supra.

The judgment is reversed, and the cause remanded, with instructions to overrule the demurrer.

Note 1. Exceptions to the Requirement of Privity. The court states that the rule at common law up until that point has been that "a manufacturer is not liable to any person other than his immediate

vendee; that the action is necessarily one upon an implied or express warranty, and that without privity of contract no suit can be maintained.” It identifies three existing exceptions: (1) Where the thing causing the injury is of a noxious or dangerous kind. (2) Where the defendant has been guilty of fraud or deceit in passing off the article. (3) Where the defendant has been negligent in some respect with reference to the sale or construction of a thing not imminently dangerous.

The first category often involved cases of mislabeling poisons or mistakes by chemists or others handling substances that had the power to injure or kill (as you saw in *Thomas v. Winchester, supra*). The second clearly marks off any actors seeking to dupe others and eliminates the privity requirement for bringing actions against them; this is the action for fraud, however, not negligence. The third allows a negligence action in cases in which an actor makes or sells something not *imminently* dangerous (but inherently dangerous, or likely to become injurious when negligently made). This third category was not widely accepted across the nation (as you will see in *MacPherson v. Buick, infra*) but it had begun to be tested in various courts and still required a showing of negligence. *Mazetti* adds a fourth exception, explaining that tort law must evolve in the face of “the changing conditions of society”:

[I]n the absence of an express warranty of quality, a manufacturer of food products under modern conditions impliedly warrants his goods when dispensed in original packages, and that such warranty is available to all who may be damaged by reason of their use in the legitimate channels of trade.

Can you restate the *Mazetti* rule, above, to identify who may, and who may not use it to recover if injured by a food product? What culpability standard appears to apply?

Note 2. Which of tort law’s purposes seems (or seem) to be driving the court’s reasoning? Where in the opinion do you see language in support of your conclusion?

Note 3. Review of Negligence Per Se’s Requirements and Limits. The majority refers to the pure food laws and, implicitly, to a theory of negligence per se based on a statutory violation. However, the various statutes appear to be limited to the *consumer’s* benefit, and the negligence per se doctrine, in defendant’s argument, pertains to the party bringing suit. In this case, the party bringing suit was *not* the consumer but a vendor. Thinking back to negligence per se, can you recall why this would matter? How do you explain the court’s working around this limitation?

Note 4. What does the court mean when it writes: “Every tradesman, whether wholesaler or retailer, is in a sense a consumer, for he buys to resell. In a way he risks his reputation”? Does the court seem to be pointing to a regime of strict liability or negligence? Why might one regime or another be normatively desirable here?

Coca-Cola Bottling Works v. Lyons, Supreme Court of Mississippi, Division B. (1927) (145 Miss. 876)

The Coca-Cola Bottling Works appeals from a judgment for \$2,500 recovered by the appellee, Mrs. Fred Lyons, as damages for personal injuries received by her on account of drinking a portion of a bottle of Coca-Cola which contained a quantity of broken glass.

We shall state only such of the facts as are necessary to an understanding of the decision of the case. The appellee, Mrs. Lyons, in company with her friend, Mrs. Jackson, drove in an automobile, to the Belen Drug Store, at Belen, in front of which they parked, and ordered drinks to be brought to them. The exact testimony on this particular point is that, "We drove up in front of the drug store, and ordered cokes." A clerk in the drug store brought two bottles of Coca-Cola to the ladies, which they proceeded to drink, and Mrs. Lyons swallowed a quantity of broken glass which was in the bottle of Coca-Cola she drank from. The bottle of Coca-Cola in question in this case had been manufactured, bottled, sealed, and delivered to the drug store to be sold to the public in the retail trade. The bottle was unsealed, or we may say uncapped, by the clerk in the drug store just before he delivered it to Mrs. Lyons. The above-stated testimony in the record is undisputed.

When the two ladies drove up and stopped in front of the drug store, Mrs. Jackson was the one who ordered the drinks, and she also paid for them; but the drinks were ordered for both of the ladies, and a bottle was delivered to each of them.

Mrs. Lyons suffered severe internal injuries on account of swallowing the broken glass in the Coca-Cola, and she testified that she suffered for many months from the effects of the glass in her stomach. There was about a tablespoonful of the broken glass in the bottle.

The recovery is based solely upon the theory that the Coca-Cola company was liable upon an implied warranty that the bottled drink was pure and wholesome, and that the fact that there was glass in the bottle when it was sealed and put upon the market for the public created liability for the injury to the one who drank it, regardless of whether the manufacturer was guilty of negligence or not. This rule is established in this state by the cases of *Coca-Cola Bottling Co. v. Chapman*, 106 Miss. 864; *Rainwater v. Coca-Cola Co.* 131 Miss. 315; and *Grapico Bottling Works v. Ennis*, 140 Miss. 502.

This being a case, then, grounded upon the theory of the breach of an implied warranty, we may discard any question arising in the record with reference to the right to recover on account of the negligence of the bottler, and proceed to ascertain whether or not recovery upon the other theory, that is, the breach of an implied warranty, can be maintained in the case. In such a case as the one before us three things only are to be ascertained, namely:

- (1) Was the glass in the bottle when it left the factory and was offered to the public?
- (2) Did the consumer have title and rightful possession of the bottle?
- (3) Did the consumer receive injury from drinking the Coca-Cola with the glass in it?

The main point presented for reversal of the judgment is that, since the right of recovery depends upon the breach of an implied warranty on the part of the manufacturer that the bottled goods were pure and wholesome, there can be no recovery in the case because there was no implied warranty of the purity of the drink for the reason that there was no contractual relation between the injured party, Mrs. Lyons, and the Coca-Cola company, or the retailer, Belen Drug Company.

It is contended that Mrs. Lyons had no contract with the clerk at the drug store who sold and delivered the Coca-Cola, for the reason that Mrs. Jackson, the lady friend with *307 her, ordered and paid for the drinks for both of them. It is urged that, therefore, there was no contractual relation between Mrs. Lyons and the manufacturer of the Coca-Cola; that the bottle of Coca-Cola was not purchased by Mrs. Lyons, but was given to her by Mrs. Jackson; that, consequently, Mrs. Lyons cannot recover upon the

theory of a breach of warranty; and that since she has made no effort to recover upon the theory of negligence the case must fail.

We have carefully considered the question, and it appears to be a new proposition in this state, so far as we are able to discover, and we are of opinion that the position of appellant is not maintainable, because, as we see it, the bottle of Coca-Cola which Mrs. Lyons drank was at least a gift to her by her friend, Mrs. Jackson, and since the gift carried with it the title, and the implied warranty runs with the title, Mrs. Lyons was the owner, and rightfully in possession thereof as one of the public when she drank the Coca-Cola, and that the manufacturer impliedly warranted the purity of the drink to such of the public as became the rightful possessor and owner of the Coca-Cola. Therefore, if the drink was injurious by reason of having glass in it, the bottling company was liable to the consumer.

There is another theory which might be offered to sustain our view just expressed, and that is that the purchase of the two bottles of Coca-Cola by Mrs. Lyons and Mrs. Jackson was a joint purchase; that is, that the sale by the drug clerk was to both of these ladies, regardless of which one ordered or paid for the drinks, the idea being that it would make no difference which one of the parties ordered the drinks, they were sold to both of the ladies, and it would not be material which one paid for them, because the contract of sale had already been made between the seller and the two purchasers, and the payment for the drinks was merely the settlement of the obligation or debt incurred by both. However, we feel that it would be better to rely upon our first view than upon the latter, because it seems that the first one is the soundest.

Complaint is made by the appellant that a certain instruction granted the appellee presented an erroneous theory to the jury, in that it told the jury that—

“If the defendant manufactured or bottled and placed upon the market the bottle of beverage called ‘Coca-Cola’ in question in this case, for human consumption, and that the plaintiff, Mrs. Lyons, purchased the said bottle of beverage in due course of trade, *** and that the said bottle of Coca-Cola so purchased contained a quantity of small particles or pieces of glass therein, *** and plaintiff was thereby damaged, it is your duty to return a verdict for the plaintiff.”

The evil claimed to exist in this instruction is that it told the jury they should find for the plaintiff if the defendant manufactured and placed on the market the bottle of beverage in question, regardless of whether the glass got into the bottle after it left the factory, or regardless of whether the method of bottling employed by the manufacturer was such that the glass could not have gotten into the bottle until after it left the manufacturer.

We do not think the instruction was erroneous because it referred to the bottle of Coca-Cola in question, and, as the testimony was undisputed that this bottle came from the manufacturer sealed, the glass must have been in the bottle before it left the factory. There is no conflict in the evidence on this point. Consequently the only thing left to the jury to decide was whether or not there was in fact glass in the bottle of Coca-Cola which Mrs. Lyons drank; and as the undisputed testimony shows that the glass was in the bottle of Coca-Cola which she drank, and that it damaged her, the instruction was correct, even though it may be considered equivalent to a peremptory instruction to find for the plaintiff. If the suit had been predicated on the theory of negligence instead of the theory of implied warranty, then our conclusion as to its correctness would be otherwise.

In the Chapman Case, *supra*, the court said:

“There is evidence for appellant that its system for cleansing and filling bottles is complete, and that there is watchfulness to prevent the introduction of foreign substances. Nevertheless, the little creature [mouse] was in the bottle.”

So, if the broken glass was in the bottle when it left the factory, the manufacturer is liable for the damage done the consumer, even though the method of bottling was complete and perfect.

But the appellant contends that, when the manufacturer shows that the method of bottling is so efficient and perfect that a foreign substance cannot get into a bottle, then a question of fact arises for the determination of the jury as to whether or not the foreign substance got into the bottle after it left the factory, and that the court in the case before us erred in not permitting the appellant to submit that question to the jury.

The point is interesting, but we do not decide now whether such proof on the part of the manufacturer as to the perfect and efficient method of bottling would raise a question of fact as to whether or not the foreign substance got into the bottle before or after it was sealed and placed upon the market, because the record in this case does not show any such perfect and complete method of bottling as would be sufficient to raise the question as contended for by the appellant; and this being true, we decline to decide it at this time. The Chapman Case, *supra*, seems to be different in this regard.

***308** This record shows that there were inspectors to inspect the bottles of Coca-Cola after they were sealed and before they left the plant to see that they contained no foreign substance. The Coca-Cola company failed to put these inspectors on the witness stand to show an inspection. The persons said to be employed to inspect were not experienced or competent, so far as the evidence shows.

The testimony offered, but refused by the court, to show the sanitary condition of the bottling plant, was properly refused, because the sanitary condition might have been all right and yet the method of bottling improper or defective to the extent of permitting foreign substances to get into the bottles of Coca-Cola before they were sealed and sent out for the use of the public.

We are not prepared to say that, if the Coca-Cola company had shown that the method of bottling was perfect, and that it was impossible for the foreign substance to get into the bottle while it was being filled and sealed, then the question of fact for the decision of the jury—whether the foreign substance got into the bottle after it left the factory—would not thus be raised; but, as we have said, the point is not presented by the record, because a perfect method of bottling was not there shown, for the reason mentioned. [***]

Counsel for appellant contend that the verdict of \$2,500 is excessive. We have reviewed the testimony on this phase of the case, and while the testimony of the plaintiff may have the marks of exaggeration or honest but unnecessary fear in it, yet it was positive, and the jury had the right to believe it. And if what the plaintiff testified to with regard to the extent of her injuries and suffering for nearly a year on account of the glass being in her stomach is true, we do not think \$2,500 is an excessive amount to be allowed for the injury. It is true that probably she ought to have offered more expert medical testimony as to the extent of her injuries than she did; however, there are some injuries and internal troubles that the injured party is fully competent to testify about. In fact, the injured person here knows more about the pain she suffered from the character of injury involved than the attending physician could possibly

know. The doctor, in such a case, generally knows only what the patient tells him, and he testifies as to the condition of the patient from what she has told him, and possibly some other slight corroborative symptoms.

The jury thought that \$2,500 was a reasonable amount for the injuries received in this case and we see no good reason for disturbing the verdict.

The judgment of the lower court is affirmed.

Note 1. Formalist versus Functionalist Legal Reasoning. The court announces that it is grounding the case in a theory of breach of implied warranty rather than negligence. It states that implied warranty will require three elements: 1) the glass must have been in the bottle when it left the factory and was offered to the public; 2) the consumer must have had title and rightful possession of the bottle; and 3) the consumer must have suffered injury from drinking the soda which contained glass. Unlike negligence, the claim for implied warranty does not require fault by the defendant. In that sense, it resembles strict liability. The court attempts to limit the scope of the tort action by insisting on a tight causal nexus (ensuring that the glass was in the bottle when it left the factory suggests nobody else could have been responsible); it then also points to the requirement of “title or rightful possession.” This provision seeks to limit the possible scope of liability by insisting on privity or a “contractual relation between the injured party” and either the manufacturer or the retailer. However, the court treats the privity requirement here as a formal technicality. It considers two means of surmounting the factual challenge present on these facts, namely that the injured party did not buy the bottle herself.

What are the two theories it considers, which does it settle on, and why? In its reasoning, it can be seen as disregarding a *formalist theory* that would insist on technically mapping the facts onto privity, even if the theory strained the concepts to do so. Instead, it opts for a *functionalist* theory that seeks to make the injured party whole and better captures the behavior and intentions of the party as well as aligning better with the purposes of the law.

Note 2. What was the defendant alleging had been erroneous about the way the jury was instructed? The court rejected this argument and agreed that it was proper to exclude the evidence defendant proffered to show the sanitary condition of the bottling plant. Can you summarize the court’s reasoning? What did it leave room for in future cases?

Note 3. Many early products liability cases were oriented in theories drawn from contract law, such as theories of warranty (express or implied) or from the law of sales. Based on what you have learned about express waivers of liability (in Module 4, in connection with Assumptions of the Risk), what do you imagine might be the costs, benefits, and limits of an approach to consumer protection that is grounded in contracts, versus torts? What theories does the court entertain in *Coca-Cola Bottling Works* to circumvent the formal bar to recovery that would be imposed if the lack of privity here were dispositive?

Note 4. The court’s discussion of damages reveals the sense of uncertainty that often attached to damages awards based on medical evidence or testimony. Because there were fewer available and fewer sophisticated methods of tracking and verifying patient’s symptoms, courts often had to make determinations based on witness credibility (and, as in cases like this, the view that the doctor could verify, at least, that the plaintiff had been complaining of these symptoms during the time period she claimed before the court). These evidentiary difficulties, and the accompanying judicial suspicions,

may help you understand the limits on allowing recovery for emotional distress, as well as their partial erosion over time as medical and psychiatric science advanced.

Note 5. The court refers to a case (*Coca-Cola Bottling Co. v. Chapman*) in which a mouse was discovered in a soda bottle. A famous case in the United Kingdom, *Donoghue v. Stevenson*, featured digestive injuries and shock when a Scottish woman discovered a decomposing snail in her ginger beer after she had already consumed most of the contents of the bottle. She brought a now-infamous lawsuit after suffering from the physical and emotional stress of the experience. The litigation was ultimately successful for the plaintiff and reshaped the British law of consumer protection by allowing a consumer to recover for injuries suffered due to a defective product even when it was not inherently dangerous and even when her friend had purchased it (which would ordinarily cause the plaintiff to fail to meet the privity requirement). While she triumphed in court, Ms. Donoghue endured public critique and character assassination for bringing the lawsuit (and it was even suggested that her “friend” was an extramarital lover). Many accounts tell the story of the lawsuit and provide details that help frame the issue:

Donoghue spied the decomposing gastropod, mixed with bits of ice cream, bobbing in a glass of ginger beer.... The sight of it would continue to haunt the Scottish woman for years to come. ...Three days after finding bits of dead mollusk in her drink, Donoghue visited a doctor for sharp pains shooting in her stomach. Three weeks later, she was hospitalized at the Glasgow Royal Infirmary with severe gastroenteritis and shock. Donoghue’s next steps — seeking out a lawyer and filing a claim against both Minghella and David Stevenson, the owner of the company that made the ginger beer — were not exactly typical for people of her background. Lawyers were for wealthy people. Donoghue, the daughter of a steelworker, was the second youngest of six and worked as a shop assistant. [S]he found the snail on August 26, 1928 — long before high-profile personal-injury lawsuits against companies like McDonald’s and Ford were the norm rather than the exception. Personal-injury laws only applied to the person who had purchased the defective product, and it was Donoghue’s friend, not her, who had paid for the ginger beer. The only exceptions were if the product was inherently dangerous or if the producer had misled the customer into thinking it was safe while knowing that it wasn’t. In either case, the ginger beer did not qualify. [A] solicitor, Walter Leechman, ... agreed to represent Donoghue pro bono. After nearly a year of preparing documents and going through legal books, Leechman and Donoghue filed a lawsuit asking for £500 in damages and £50 in court fees. The sum, worth approximately £35,000 (\$45,000) in today’s money, was considered extravagantly large. As with many personal-injury cases today, the matter became about much more than the incident itself — and it came at great personal cost to Donoghue.

If you’re curious to read (or listen to) more, you’ll find it here <https://narratively.com/the-woman-who-found-a-snail-in-her-soda-and-launched-a-million-lawsuits/>

Note 6. Should it matter what is found in the cola bottle so long as it isn’t Coke? Should worse things give rise to higher damages? Or lower requirements of proof of negligence? Should it be material if the item is particularly objectionable, such as an “unpackaged prophylactic” (i.e. a used condom)? *Wallace v. Coca-Cola Bottling Plants, Inc.*, 269 A.2d 117, 121–22 (Me. 1970), overruled on other grounds by *Culbert v. Sampson’s Supermarkets Inc.*, 444 A.2d 433 (Me. 1982) (upholding a

jury verdict for plaintiff when “defendant negligently caused or permitted a foreign object to enter a bottle of Coca-Cola it had processed. The foreign object was of such a loathsome nature it was reasonably foreseeable its presence would cause nausea and mental distress upon being discovered in the place it was by a consumer who was in the process of drinking from the bottle. The mental distress was manifested by vomiting.”)

The next case became the foundational case in the United States for the idea that privity would no longer be necessary for recovery under tort law, at least in cases where injury was caused by an inherently dangerous product.

The Collapse of Privity

MacPherson v. Buick Motor Co. Court of Appeals of New York (1916) (217 N.Y. 382) Justice Cardozo

The defendant is a manufacturer of automobiles. It sold an automobile to a retail dealer. The retail dealer resold to the plaintiff. While the plaintiff was in the car it suddenly collapsed. He was thrown out and injured. One of the wheels was made of defective wood, and its spokes crumbled into fragments. The wheel was not made by the defendant; it was bought from another manufacturer. There is evidence, however, that its defects could have been discovered by reasonable inspection, and that inspection was omitted. There is no claim that the defendant knew of the defect and willfully concealed it. [***]The charge is one, not of fraud, but of negligence. The question to be determined is whether the defendant owed a duty of care and vigilance to anyone but the immediate purchaser.

[The court here reviews earlier cases that diverge. Some cases had held that the manufacturer owed a duty to ultimate purchasers when the product was “inherently dangerous.” Other cases narrowed this rule so that the inherently dangerous classification would be limited to guns, poisons or other products intended or likely to injure or destroy. A third set proposed a rule that imposed liability for products that became injurious when negligently made; Cardozo followed this third line.]

If the nature of a thing is such that it is reasonably certain to place life and limb in peril when negligently made, it is then a thing of danger. Its nature gives warning of the consequences to be expected. If to the element of danger there is added knowledge that the thing will be used by persons other than the purchaser, and used without new tests, then, irrespective of contract, the manufacturer of this thing of danger is under a duty to make it carefully. That is as far as we are required to go for the decision of this case.

There must be knowledge of a danger, not merely possible, but probable. It is possible to use almost anything in a way that will make it dangerous if defective. That is not enough to charge the manufacturer with a duty independent of his contract. Whether a given thing is dangerous may be sometimes a question for the court and sometimes a question for the jury. There must also be knowledge that in the usual course of events the danger will be shared by others than the buyer. Such knowledge may often be inferred from the nature of the transaction. But it is possible that even knowledge of the danger and of the use will not always be enough. The proximity or remoteness of the relation is a factor to be considered. We are dealing now with the liability of the manufacturer of the

finished product, who puts it on the market to be used without inspection by his customers. If he is negligent, where danger is to be foreseen, a liability will follow.

We have put aside the notion that the duty to safeguard life and limb, when the consequences of negligence may be foreseen, grows out of contract and nothing else. We have put the source of the obligation where it ought to be. We have put its source in the law. [***]

In this view of the defendant's liability there is nothing inconsistent with the theory of liability on which the case was tried. It is true that the court told the jury that "an automobile is not an inherently dangerous vehicle." The meaning, however, is that danger is not to be expected when the vehicle is well constructed. The court left it to the jury to say whether the defendant ought to have foreseen that the car, if negligently constructed, would become "imminently dangerous." Subtle distinctions are drawn by the defendant between things inherently dangerous and things imminently dangerous, but the case does not turn upon these verbal niceties. If danger was to be expected as reasonably certain, there was a duty of vigilance, and this whether you call the danger inherent or imminent. In varying forms that thought was put before the jury. We do not say that the court would not have been justified in ruling as a matter of law that the car was a dangerous thing. If there was any error, it was none of which the defendant can complain.

We think the defendant was not absolved from a duty of inspection because it bought the wheels from a reputable manufacturer. It was not merely a dealer in automobiles. It was responsible for the finished product. It was not at liberty to put the finished product without subjecting the component parts to ordinary and simple tests [c]. Under the charge of the trial judge nothing more was required of it. The obligation to inspect must vary with the nature of the thing to be inspected. The more probable the danger the greater the need of caution. [***]

The judgment should be affirmed with costs.

Note 1. Privity. Identify the rationales for the original doctrine. How and why does Cardozo choose to limit privity? How does his opinion seem to serve the various purposes of tort law? Does it strike you as being at odds with his ruling in *Palsgraf*?

Note 2. Contrary views. A vigorous dissent in *MacPherson* by Justice Bartlett began by reciting the traditional rule of privity: "[A] contractor, manufacturer, vendor or furnisher of an article is not liable to third parties who have no contractual relations with him for negligence in the construction, manufacture or sale of such article." (2 Cooley on Torts [3d ed.], 1486.) *MacPherson v. Buick Motor Co.*, 217 N.Y. 382, 397, 111 N.E. 1050 (1916). He noted the exceptions to the rule, which in his opinion, failed to apply here: "The exceptions to this general rule which have thus far been recognized in New York are cases in which the article sold was of such a character that danger to life or limb was involved in the ordinary use thereof; in other words, where the article sold was inherently dangerous. As has already been pointed out, the learned trial judge instructed the jury that an automobile is not an inherently dangerous vehicle." *Id.* He forcefully rejected the idea that privity *could* be dispensed with here, short of overruling venerable precedents from England as well as New York.

I do not see how we can uphold the judgment in the *400 present case without overruling what has been so often said by this court and other courts of like authority in reference to the absence of any liability for negligence on the part of the original vendor of an ordinary carriage to any one except his immediate vendee. The absence

of such liability was the very point actually decided in the English case of *Winterbottom v. Wright*, and the illustration quoted from the opinion of Chief Judge RUGGLES in *Thomas v. Winchester* assumes that the law on the subject was so plain that the statement would be accepted almost as a matter of course. In the case at bar the defective wheel on an automobile moving only eight miles an hour was not any more dangerous to the occupants of the car than a similarly defective wheel would be to the occupants of a carriage drawn by a horse at the same speed; and yet unless the courts have been all wrong on this question up to the present time there would be no liability to strangers to the original sale in the case of the horse-drawn carriage. *Id.* at 399–400.

Justice Bartlett’s concerns can be captured concisely in his citation to an early English case, *Winterbottom v. Wright*, quoting from Lord Abinger: “Unless we confine the operation of such contracts as this to the parties who enter into them, the most absurd and outrageous consequences, to which I can see no limit, would ensue.” *Id.* at 396-397.

Are these concerns overblown? Why or why not?

Note 3. Scope. Can you tell from this opinion how far the court wishes to extend the possible field of liability for products bearing extra risks or defects that the customer will not have an opportunity to inspect?

Note 4. The Pace and Nature of Common Law Change. *MacPherson* is often cast as the case that toppled the “citadel” of privity, or the longstanding limitations it represented. *See* William L. Prosser, *The Fall of the Citadel (Strict Liability to the Consumer)*, 50 Minn. L. Rev. 791, 799 (1966). Yet the holding of the case was often limited in ways that continued, effectively, to serve as barriers to recovery. Consider again, *Redmond v. Borden’s Farm Products Co.* (245 N.Y. 512, 1927), mentioned as a note case *supra* under “Federal Regulation and the Slow Changes in State Tort Law”). *Redmond* held that a fourteen-month-old infant who lacked privity with a dairy farm could not recover for injuries sustained while she was drinking milk out of a glass bottle purchased by her parent). If *MacPherson* truly “toppled” the citadel of privity, how could a case decided almost a decade later still find that privity barred recovery for innocent injury? Is an automobile sufficiently different from a bottle of milk? Was there a difference in the manufacturers’ duties to inspect? Is there some other way to distinguish or reconcile the cases?

In fact, privity released its grip on the common law over decades rather than overnight. Even in New York, which was bound by *MacPherson’s* decision, and even as late as 1961, the Court of Appeals wrestled with how to resolve a case of injury in which the victim lacked formal privity with the defendant. In *Greenberg v. Lorenz*, a fifteen year-old, Sheila, was injured by a sharp metal object in a can of salmon purchased by her father. While the court *did* permit the plaintiff to recover despite the lack of privity, the court seemed to feel obliged to defend its reasoning.

In our view, the father’s purchase of the can of salmon to be eaten not by himself alone, but by the members of his household, including the plaintiff Sheila as well, was clearly one made by him for the entire household. [***] *885 It is not without interest in this case, though we need not test our decision on the incident, that the salmon was bought at *Sheila’s* own request, because she preferred it to tuna fish which her mother had originally intended to serve at the evening meal. *Greenberg v. Lorenz*, 12 Misc. 2d 883,

885 (App. Term 1958), aff'd as modified, 7 A.D.2d 968, (1959), aff'd and modified, 9 N.Y.2d 195 (1961).

In the passage above, the court pointed out the father's intent to provide for the whole household as well as Sheila's request for this particular food, as though suggesting that *her* intent ought to be relevant in considering privity. It offered these factors to supplement an argument that the lack of privity should not be determinative on these facts.

It also turned to policy considerations. Food manufacturers necessarily contemplate a set of consumers broader than the purchasers, especially when advertising to parents who buy and prepare food for children:

In the case of highly advertised 'baby foods,' for instance, what can be fairly and reasonably urged to deny a tender infant recovery because it cannot claim that an umbilical cord of privity attaches it to a monolithic 'chain store?' TV, radio, billboard, magazine and newspaper advertising zoom forth strident ballyhoo and urgent 'invitations to deal,' addressed to fathers and mothers, to be sure but actually intended for the special benefit of their infants—for whom the foods have been primarily processed. As between weakening of privity in these food cases and diminishing consumer protection, common sense, as well as good conscience, permit no choice. 'It is a melancholy state of affairs to witness courts more preoccupied with privity than consumer protection.' *Id.*

The court states its values plainly in prioritizing protection over privity but it does not do so lightly. It bolsters its arguments by noting the "constantly mounting criticism leveled at the requirement of strict contractual privity in this type of case" and concludes that privity can longer be understood to "confine the right of recovery to the very individual who made the purchase." *Id.* at 886.

In the light of today's conditions it is fair to say that the rule is all but an anachronism—weighed on the scales of reality, it is found wanting. And, indeed it has been rejected outright in some jurisdictions, and denigrated in others in 'domestic meals' cases. This process has been supported on different bases: 'household agency', 'agency for the consumer', or 'third party beneficiary'. The activating dynamic, however, has been constant, although variously called: 'public policy', 'breach of duty', 'privity imposed by operation of law', and simply 'social justice'. *Id.*

Finally, it is noteworthy that the court could not identify precisely the theory underlying the right of recovery in the absence of privity but articulated strong views in favor of it nonetheless:

If it is not altogether clear whether it is on the theory of implied agency or third party beneficiary doctrine, or because it is a 'wrongful act, neglect, or default' (*Greco v. S. S. Kresge Co.*, 277 N.Y. 26, 12 N.E.2d 557, 560, 115 A.L.R. 1020), it is manifest, nevertheless, that in these cases of the breach of an implied warranty of fitness for use in connection with the sale of foodstuffs, the traditional concept of privity no longer constrains the courts to an absurd as well as unconscionable result. *Id.* at 887.

Given what you understand about the common law, how would you explain the persistence of privity after *MacPherson*, even in cases like *Redmond* (almost a decade later) and *Greenberg* (45 years later)?

What valuable role did privity serve? Why did the court not find it applied here? Which parts of the opinion are descriptive, and which parts are normative?

Note 5. Torts versus Contracts. What are the implications for *Macpherson's* (famous) dicta below, from the perspectives of consumers and the various stakeholders affected by tort law?

We have put aside the notion that the duty to safeguard life and limb, when the consequences of negligence may be foreseen, grows out of contract and nothing else. We have put the source of the obligation where it ought to be. We have put its source in the law.

Why does it matter whether contract or tort law provides the basis for recovery? What is the difference between a *warranty* and a contract? Does *MacPherson* feel like a natural extension of *Mazetti*? In what ways do these two cases diverge (descriptively) and to what extent (normatively), *should* they diverge or adopt parallel reasoning?

The next case explores express warranties and representations made to the buyer of a car.

Chapter 27. Express Warranty

Baxter v. Ford Motor Co., Supreme Court of Washington (1932) (168 Wash. 456)

During the month of May, 1930, plaintiff purchased a model A Ford town sedan from defendant St. John Motors, a Ford dealer, who had acquired the automobile in question by purchase from defendant Ford Motor Company. Plaintiff claims that representations were made to him by both defendants that the windshield of the automobile was made of nonshatterable glass which would not break, fly, or shatter. October 12, 1930, while plaintiff was driving the automobile through Snoqualmie pass, a pebble from a passing car struck the windshield of the car in question, causing small pieces of glass to fly into plaintiff's left eye, resulting in the loss thereof. Plaintiff brought this action for damages for the loss of his left eye and for injuries to the sight of his right eye. The case came on for trial, and, at the conclusion of plaintiff's testimony, the court took the case from the jury and entered judgment for both defendants. From that judgment, plaintiff appeals. [***]

The principal question in this case is whether the trial court erred in refusing to admit in evidence, as against respondent Ford Motor Company, the catalogues and printed matter furnished by that respondent to respondent St. John Motors to be distributed for sales assistance. Contained in such printed matter were statements which appellant maintains constituted representations or warranties with reference to the nature of the glass used in the windshield of the car purchased by appellant. A typical statement, as it appears in appellant's exhibit for identification No. 1, is here set forth:

“Triplex Shatter-Proof Glass Windshield. All of the new Ford cars have a Triplex shatter-proof glass windshield—so made that it will not fly or shatter under the hardest impact. This is an important safety factor because it eliminates the dangers of flying glass—the cause of most of the injuries in automobile accidents. In these days of crowded, heavy traffic, the use of this Triplex glass is an absolute necessity. Its extra margin of safety is something that every motorist should look for in the purchase of a car—especially where there are women and children.”

Respondent Ford Motor Company contends that there can be no implied or express warranty without privity of contract, and warranties as to personal property do not attach themselves to, and run with, the article sold.

[The court here referred at length to *Mazetti v. Armour & Co.*, 75 Wash. 622 (1913)]

In the case at bar the automobile was represented by the manufacturer as having a windshield of nonshatterable glass “so made that it will not fly or shatter under the hardest impact.” An ordinary person would be unable to discover by the usual and customary examination of the automobile whether glass which would not fly or shatter was used in the windshield. In that respect the purchaser was in a position similar to that of the consumer of a wrongly labeled drug, who has bought the same from a retailer, and who has relied upon the manufacturer's representation that the label correctly set forth the contents of the container. For many years it has been held that, under such circumstances, the manufacturer is liable to the consumer, even though the consumer purchased from a third person the

commodity causing the damage. *Thomas v. Winchester*, 6 N.Y. 397. The rule in such cases does not rest upon contractual obligations, but rather on the principle that the original act of delivering an article is wrong, when, because of the lack of those qualities which the manufacturer represented it as having, the absence of which could not be readily detected by the consumer, the article is not safe for the purposes for which the consumer would ordinarily use it.

The vital principle present in the case of *Mazetti v. Armour & Co.*, supra, confronts us in the case at bar. In the case cited the court recognized the right of a purchaser to a remedy against the manufacturer because of damages suffered by reason of a failure of goods to comply with the manufacturer's representations as to the existence of qualities which they did not in fact possess, when the absence of such qualities was not readily discoverable, even though there was no privity of contract between the purchaser and the manufacturer.

Since the rule of *caveat emptor* was first formulated, vast changes have taken place in the economic structures of the English speaking peoples. Methods of doing business have undergone a great transition. Radio, billboards, and the products of the printing press have become the means of creating a large part of the demand that causes goods to depart from factories to the ultimate consumer. It would be unjust to recognize a rule that would permit manufacturers of goods to create a demand for their products by representing that they possess qualities which they, in fact, do not possess, and then, because there is no privity of contract existing between the consumer and the manufacturer, deny the consumer the right to recover if damages result from the absence of those qualities, when such absence is not readily noticeable. "An exception to a rule will be declared by courts when the case is not an isolated instance, but general in its character, and the existing rule does not square with justice. Under such circumstances a court will, if free from the restraint of some statute, declare a rule that will meet the full intendment of the law." *Mazetti v. Armour & Co.*, supra.

We hold that the catalogues and printed matter furnished by respondent [***] Ford Motor Company for distribution and assistance in sales were improperly excluded from evidence, because they set forth representations by the manufacturer that the windshield of the car which appellant bought contained Triplex nonshatterable glass which would not fly or shatter. The nature of nonshatterable glass is such that the falsity of the representations with reference to the glass would not be readily detected by a person of ordinary experience and reasonable prudence. Appellant, under the circumstances shown in this case, had the right to rely upon the representations made by respondent Ford Motor Company relative to qualities possessed by its products, even though there was no privity of contract between appellant and respondent Ford Motor Company. [***]

The trial court erred in taking the case from the jury and entering judgment for respondent Ford Motor Company. It was for the jury to determine under proper instructions, whether the failure of respondent Ford Motor Company to equip the windshield with glass which did not fly or shatter was the proximate cause of appellant's injury. [***]

Reversed, with directions to grant a new trial with reference to respondent Ford Motor Company; affirmed as to respondent St. John Motors.

Note 1. What if the defendant in *Baxter* could not find safer glass to use, because none existed? What if they had used their very best efforts to find better glass, and genuinely and accurately believed that the glass they used was the safest available?

Note 2. Ford tried to argue that any warranties “run with the article sold.” What would that mean, in practical terms? Would it contravene the rule in *MacPherson*?

Note 3. The consumer in *Baxter* claims to have relied on the representations made in the express warranty. Does this assertion seem like a mere pretext to recover from an ordinary car accident? Or does it seem sound to hold the defendant to claims made in their brochure? Should the plaintiff have to prove **reasonable reliance** on the brochure, namely, that they reasonably relied on it in deciding to purchase the car (and perhaps would not otherwise have purchased it)? What does it do to the duties of those in the position to make such claims if reasonable or justifiable reliance by the consumer is a requirement for recovery under tort law? Does it sound in contract or tort law, in your estimation? Finally, does the conduct by the defendant here seem to generate liability more on the basis of negligence or strict liability?

Note 4. Why does the court believe that it was error to exclude the catalogues and printed advertising of Ford Motor Company in the prior litigation? On what grounds do you think the lower court likely excluded it in the first place?

Coca-Cola Bottling Co. of Helena v. Mattice, Supreme Court of Arkansas (1951) (219 Ark. 428)

Appellee, Dr. H. W. Mattice, recovered a verdict and judgment for \$12,500 against appellant, Coca-Cola Bottling Co. of *429 Helena, Arkansas for injuries sustained from the alleged explosion of a bottle of Coca-Cola manufactured by appellant at its bottling plant in Forrest City, Arkansas.

[***] Appellee resides at Marianna, Arkansas where he has engaged in the practice of dentistry since 1922. About 10 a. m. on the day of his injury in September, 1947 appellee’s wife purchased from a Marianna grocer a case of Coca-Colas which had been delivered to the grocery store by a truck from appellant’s plant at Forrest City. The case of drinks was removed from a stack in the store where it had been placed by appellant’s truck driver and carefully placed in the car driven by appellee’s wife and transported to the Mattice home. Mrs. Mattice carefully placed the case behind a shrub where such drinks were usually kept.

After lunch at the Mattice home, appellee, his daughter, Clyde Mattice, and office assistant, Sybil Rice, started to return to appellee’s office in his car about 1 p.m., when appellee indicated that he would like to take some Coca-Colas to the office. Either Mrs. Mattice or Miss Rice took five or six bottles of Coca-Cola from the case and placed them on the floor of the rear compartment of the two-door sedan on the right side with the bottles lying flat on the floor and the crowns facing the rear seat. Clyde Mattice entered the front seat and appellee the rear seat of the car. Appellee was seated slightly to the left side on the rear seat of the car and was reaching over the bottles of Coca-Cola to open the right hand car door for Miss Rice to enter, when one of the bottles exploded. Appellee’s hand was about twenty-four inches above the bottles and the flying glass severed the radial nerve of his right wrist and cut his index finger. Since there is no contention that the verdict is excessive, we refrain from further detail of the serious and disabling nature of the injury. Appellee and his daughter were positive in their

statements that he did not touch the bottles with his feet *430 and that said bottles were not otherwise agitated after they were placed on the floor of the car.

At the conclusion of the testimony on behalf of appellee, appellant moved for an instructed verdict on the ground that appellee had failed to establish the material allegations of the complaint and particularly the allegation that appellant was negligent in putting too high a carbonation in and otherwise negligently charging, filling, and capping the bottle which allegedly caused the injury. The motion was overruled on the ground that a prima facie case had been made under the doctrine of *res ipsa loquitur*, which the court held applicable.

Appellant then offered general but detailed proof of its bottling operation at its Forrest City plant about the time of the injury showing the various precautionary steps in the bottling process designed to prevent overcharging with carbonation or the use of defective bottles. Although daily written reports were made showing the hourly bottle pressure, bottle temperature and gas volume employed in the bottling process in September, 1947, such records were not preserved or introduced in evidence.

Scientific proof was also introduced to show that Coca-Cola bottles generally could withstand pressures several times greater than appellant's equipment, when properly used, could put in them and that during the bottling process the bottles were subjected to such pressure as to eliminate weak or defective bottles. There was also general proof to the effect that the bottled product was handled carefully in making deliveries to retail stores but no specific proof as to the manner in which the case in question was handled.

Appellant's first contention for reversal is that the trial court erred in holding the doctrine of *res ipsa loquitur* applicable. We held the doctrine applicable to exploding bottled beverages in the recent case of Coca-Cola Bottling Co. of Fort Smith v. Hicks, 215 Ark. 803, but it is insisted that this is the minority rule and that appellee's proof is insufficient to invoke *431 the rule announced in that case. We there held that the fact that the instrumentality causing an injury may have actually passed out of the physical possession of the defendant does not foreclose application of the *res ipsa loquitur* doctrine, 'when a plaintiff shows that an exploding bottle was handled with due care after it left the control of the defendant, and that the bottle had not been subject to extraneous harmful forces during that time'. It is undisputed that the case of Coca-Colas which contained the bottle which later exploded was delivered to T. K. Fong's Grocery by appellant. Appellee offered testimony tending to show that the case of Coca-Colas remained undisturbed in the store where it was stacked by appellant's driver until it was carefully placed in appellee's car and transported to his home and deposited in the shrubbery near the house where it remained unmolested for about two hours when six of the bottles were removed and placed on the car floor without any undue handling of the bottles. There was further evidence that the six bottles were in no manner disturbed from the time they were placed on the floor until the bottle exploded.

In instructions requested by both parties the jury was required to find, and the burden was placed on appellee to show, that the explosion was not caused by any act of appellee or third persons who may have handled the bottle and that no other independent cause intervened to bring about the explosion from the time the bottle left the control of appellant. When the evidence is considered in the light most favorable to appellee, we deem it sufficient to satisfy the burden thus placed upon him.

It is next argued that even if the *res ipsa* doctrine is applicable, the prima facie case made by appellee, or the presumption of negligence arising from proof of the circumstances of the injury, was completely

dispelled when appellant ‘offered’ proof of its due care ‘at or about’ the time the bottle of Coca-Cola in question was manufactured and sold. [***] If the prima facie case made by plaintiff in a case where the doctrine of *res ipsa loquitur* is applicable may be completely dissipated by merely offering some proof of due care on defendant’s part, then the whole doctrine is dangerously weakened if not completely devitalized. If the trier of facts is bound to accept such offered proof regardless of its questionable or perjured character, the jury’s time-honored province of determining the credibility of witnesses and the weight to be given testimony is not only invaded but utterly subdued.

We next consider the assignments of error relating to the giving of Plaintiff’s Requested Instructions Nos. 2 and 3, which read:

‘No. 2. If you find from a preponderance of the testimony that the bottle of Coca Cola exploded and proximately caused the injury complained of, was manufactured, sold and distributed by the defendant herein and that it actually exploded and caused the injury; and you further find from a preponderance of the evidence that there was no negligence on the part of the plaintiff H. W. Mattice and that no independent cause intervened between the time the bottle left the exclusive possession of the defendant and the time of the explosion, that would cause the explosion, you are then instructed that the fact of the explosion of the said bottle raises a presumption of negligence on the part of the defendant and your verdict will be for the plaintiff, unless you should find that the presumption of negligence has been overcome by evidence on the part of the defendant.

***435** ‘Upon proof of the fact of the explosion, as set out in the above instruction, the burden of proof then shifts to the defendant to show by a preponderance of the evidence that it was free from negligence and upon failure of the defendant to meet that burden of proof you will be warranted in finding for the plaintiff.’

‘No. 3. You are instructed that where the explosion is caused by a bottle of Coca-Cola that is under the control and custody of the defendant, or that after it left the control and custody of the defendant it is shown by a preponderance of the evidence that the bottle has not been subjected to extraneous harmful forces during that time, and that the explosion and injury is such that in the ordinary course of things would not occur, if those who have such control and custody use proper care, the happening of the explosion with the resulting damage is prima facie evidence of negligence, and shifts to the defendant the burden of proving that it was not caused by the negligence of the defendant.’

Each of the instructions was specifically objected to because it placed the burden of proof in the whole case on appellant to show that it was not guilty of negligence when the burden is actually upon appellee to prove negligence and because the instructions set up two different burdens for appellant and were contradictory within themselves and with other instructions given. In disposing of this contention, we examine briefly the development of the *res ipsa* doctrine. It was announced by the English courts apparently as a court-made rule of substantive law. The English decisions hold that the presumption of negligence arising under the doctrine is a legal presumption which shifts the burden of proof to defendant to prove himself free from negligence by a preponderance of the evidence. The English cases were followed by early decisions in this country. Typical of these is our own case of *Railway Co. v.*

Hopkins, 54 Ark. 209, where an instruction was approved which definitely recognized the burden shifting rule. [***]

In later American cases much confusion and division of authority have developed concerning the effect of the doctrine on the burden of proof, as is demonstrated by the following statement in 65 C.J.S., Negligence, § 220(9) b: ‘The general rule, as broadly stated in the cases, is that, where plaintiff has established a presumptive or *prima facie* case of negligence by virtue of the doctrine of *res ipsa loquitur*, it is then incumbent on defendant, if he wishes to avoid the effect of the doctrine or the risk of the inference or presumption which may arise, to introduce evidence to explain, rebut, or otherwise overcome the presumption or inference that the injury complained of was due to negligence on his part.

[c] [T]he general rule that the burden of proving negligence on the part of defendant rests throughout the trial on plaintiff is generally held not affected by the doctrine of *res ipsa loquitur*, and the burden is still on plaintiff to establish the negligence of defendant, and, on the whole evidence, he must have the preponderance in order to succeed, although where defendant *437 fails to overcome the presumption or inference raised by the doctrine this burden is sustained. The application of the doctrine of *res ipsa loquitur* does not convert defendant’s plea of the general issue or general denial into an affirmative defense with respect to the burden of proof.’ The confusion becomes more confounded when the list of cases cited in support of the above statement shows several states following both views.

While our earlier cases clearly recognized the rule as adopted by the English courts, later cases have adopted the so-called general rule as above stated and hold that the true burden of proof in the sense of the risk of nonpersuasion does not shift but that the burden of producing or going forward with the evidence does shift.

In *Arkansas Light and Power Co. v. Jackson*, *supra*, [c], the following instruction was challenged:

‘You are instructed that, where injury or death is caused by a thing or instrumentality that is under the control or management of the defendant, and the injury or death is such that in the ordinary course of things would not occur, if those who have such control or management use proper care, the happening of the injury is *prima facie* evidence of negligence, and shifts to the defendant the burden of proving that it was not caused through lack of care on defendant’s part.’ In approving this instruction the court said: ‘This instruction does not tell the jury there was a presumption of negligence from the mere occurrence of the injury, nor did it relieve the plaintiff from the burden of proving negligence. The burden of proof to establish negligence was on the plaintiff, and the instruction did not shift this burden. ...

‘The doctrine of *res ipsa loquitur* does not relieve the plaintiff of the burden of proving negligence; it merely declares the conditions under which a *prima facie* showing of negligence has been made, and, where this has been done, the defendant having the custody and control of the agency causing the injury and the opportunity to make the examination to discover the cause, must furnish the explanation which this opportunity affords to overcome the *prima facie* showing made by the plaintiff. Such is the purport of the instruction as we understand it, and no error was committed *438 in giving it under the facts of this case.’ [***]

[W]e find no error in the giving of Plaintiff’s Requested Instruction No. 3 or the first paragraph of Instruction No. 2. But the language of paragraph 2 of Plaintiff’s Requested Instruction No. 2 clearly shifted the true burden of proof to the appellant to show by a preponderance of all the evidence that it was free from negligence. It conflicted with other instructions given placing the burden of proof on appellee to establish his case by a preponderance of all the evidence. In the annotation in 42 A.L.R. 865 numerous cases are cited from those jurisdictions which recognize the so-called general rule, holding the giving of similar instructions prejudicial and ground for reversal. So we hold that the giving of paragraph 2 of Requested Instruction No. 2 resulted in reversible error. [***]

For the error indicated in the giving of Appellee’s Requested Instruction No. 2, the judgment is reversed and the cause remanded for a new trial.

Note 1. Review the three prongs of the test for *res ipsa loquitur* (discussed in connection with *Byrne v. Boadle*, Court of Exchequer (1863) in Module 3) in light of the analysis above. Review our earlier discussion of the distinctions between the burden of *production* (which the court here refers to as the “burden of going forward”) and the burden of *persuasion*. Recall, too *Rodriguez v. City of New York*, 31 N.Y.3d 312 (2018) in Module 4 and the dueling opinions’ view of whether the plaintiff on a summary judgment must prove that they are free from negligence to prevail at that stage. What is the significance here, of where to place the burden? What is at stake and why might it either differ or resemble the comparative fault context of *Rodriguez*?

Note 2. You have learned that burden-shifting is a device through which legal rules can “place a thumb on the scale” for a party, that is, can help a party on a given issue or action. It is not usually fully dispositive (although it can be); typically it does provide some meaningful assistance. As you encounter various different kinds of actions in products liability law, consider whether the underlying policy concerns, and tort law’s purposes, justify existing or additional use of burden-shifting devices in order to assist stakeholders at different points in legal conflicts. The next case features another exploding Coca-Cola bottle. The majority opinion deploys *res ipsa loquitur* again, while the concurrence, penned the extremely influential Justice Traynor, provides a harbinger of the strict liability rule that will follow in a later landmark case for which he writes the majority opinion. Normatively, consider the arguments in favor of channeling plaintiffs through the standard negligence action versus permitting them to use strict liability to recover.

**Escola v. Coca Cola Bottling Co. of Fresno, Supreme Court of California
(1944)
(24 Cal.2d 453) En bank [sic]**

Plaintiff, a waitress in a restaurant, was injured when a bottle of Coca Cola broke in her hand. She alleged that defendant company, which had bottled and delivered the alleged defective bottle to her employer, was negligent in selling ‘bottles containing said beverage which on account of excessive pressure of gas or by reason of some defect in the bottle was dangerous ... and likely to explode.’ This appeal is from a judgment upon a jury verdict in favor of plaintiff.

Defendant’s driver delivered several cases of Coca Cola to the restaurant, placing them on the floor, one on top of the other, under and behind the counter, where they remained at least thirty-six hours.

Immediately before the accident, plaintiff picked up the top case and set it upon a near-by ice cream cabinet in front of and about three feet from the refrigerator. She then proceeded to take the bottles from the case with her right hand, one at a time, and put them into the refrigerator. Plaintiff testified that after she had placed three bottles in the refrigerator and had moved the fourth bottle about 18 inches from the case 'it exploded in my hand.' The bottle broke into two jagged pieces and inflicted a deep five-inch cut, severing blood vessels, nerves and muscles of the thumb and palm of the hand. Plaintiff further testified that when the bottle exploded, 'It made a sound similar to an electric light bulb that would have dropped. It made a loud pop.' Plaintiff's employer testified, 'I was about twenty feet from where it actually happened and I heard the explosion.' A fellow employee, on the opposite side of the counter, testified that plaintiff 'had the bottle, I should judge, waist high, and I know that it didn't bang either the case or the door or another bottle,' when it popped. It sounded just like a fruit jar would blow up...' The witness further testified that the contents of the bottle 'flew all over herself and myself and the walls and one thing and another.'

The top portion of the bottle, with the cap, remained in plaintiff's hand, and the lower portion fell to the floor but did not break. The broken bottle was not produced at the trial, the pieces having been thrown away by an employee of the restaurant shortly after the accident. Plaintiff, however, described the broken pieces, and a diagram of the bottle was made showing the location of the 'fracture line' where the bottle broke in two.

***457** One of defendant's drivers, called as a witness by plaintiff, testified that he had seen other bottles of Coca Cola in the past explode and had found broken bottles in the warehouse when he took the cases out, but that he did not know what made them blow up.

Plaintiff then rested her case, having announced to the court that being unable to show any specific acts of negligence she relied completely on the doctrine of *res ipsa loquitur*. Defendant contends that the doctrine of *res ipsa loquitur* does not apply in this case, and that the evidence is insufficient to support the judgment. Many jurisdictions have applied the doctrine in cases involving exploding bottles of carbonated beverages. [cc] It would serve no useful purpose to discuss the reasoning of the foregoing cases in detail, since the problem is whether under the facts shown in the instant case the conditions warranting application of the doctrine have been satisfied.

Res ipsa loquitur does not apply unless (1) defendant had exclusive control of the thing causing the injury and (2) the accident is of such a nature that it ordinarily ***458** would not occur in the absence of negligence by the defendant. [cc] Many authorities state that the happening of the accident does not speak for itself where it took place some time after defendant had relinquished control of the instrumentality causing the injury. Under the more logical view, however, the doctrine may be applied upon the theory that defendant had control at the time of the alleged negligent act, although not at the time of the accident, *provided* plaintiff first proves that the condition of the instrumentality had not been changed after it left the defendant's possession. [***] As said in *Dunn v. Hoffman Beverage Co.*, 126 N.J.L. 556, 'defendant is not charged with the duty of showing affirmatively that something happened to the bottle after it left its control or management; [***] to get to the jury the plaintiff must show that there was due care during that period.' (3) Plaintiff must also prove that she handled the bottle carefully. The reason for this prerequisite is set forth in *Prosser on Torts*, *supra*, at page 300, where the author states: 'Allied to the condition of exclusive control in the defendant is that of absence of any action on the part of the plaintiff contributing to the accident. Its purpose, of course, is to eliminate the possibility that it was the plaintiff who was responsible. If the boiler of a locomotive

explodes while the plaintiff engineer is operating it, the inference of his own negligence is at least as great as that of the defendant, and *res ipsa loquitur* will not apply until he has accounted for his own conduct.' [c] It is not necessary, of course, that plaintiff eliminate every remote possibility of injury to the bottle after defendant lost control, and the requirement is satisfied if there is evidence permitting a reasonable inference that it was not accessible to extraneous harmful forces and that it was carefully handled by plaintiff or any third person who may have moved or touched it. Cf. Prosser, *supra*, p. 300. If such evidence is presented, the question becomes one for the trier of fact (see, e. g., *459 *MacPherson v. Canada Dry Ginger Ale, Inc.*, 129 N.J.L. 365), and, accordingly, the issue should be submitted to the jury under proper instructions.

In the present case no instructions were requested or given on this phase of the case, although general instructions upon *res ipsa loquitur* were given. Defendant, however, has made no claim of error with reference thereto on this appeal. Upon an examination of the record, the evidence appears sufficient to support a reasonable inference that the bottle here involved was not damaged by any extraneous force after delivery to the restaurant by defendant. It follows, therefore, that the bottle was in some manner defective at the time defendant relinquished control, because sound and properly prepared bottles of carbonated liquids do not ordinarily explode when carefully handled.

The next question, then, is whether plaintiff may rely upon the doctrine of *res ipsa loquitur* to supply an inference that defendant's negligence was responsible for the defective condition of the bottle at the time it was delivered to the restaurant. Under the general rules pertaining to the doctrine, as set forth above, it must appear that bottles of carbonated liquid are not ordinarily defective without negligence by the bottling company. [***]

An explosion such as took place here might have been caused by an excessive internal pressure in a sound bottle, by a defect in the glass of a bottle containing a safe pressure, or by a combination of these two possible causes. The question is whether under the evidence there was a probability that defendant was negligent in any of these respects. If so, the doctrine of *res ipsa loquitur* applies. The bottle was admittedly charged with gas under pressure, and the charging of the bottle was within the exclusive control of defendant. As it is a matter of common knowledge that an overcharge would not ordinarily result without negligence, it follows under the doctrine of *res ipsa loquitur* that if the bottle was in fact excessively charged an inference of defendant's negligence would arise. If *460 the explosion resulted from a defective bottle containing a safe pressure, the defendant would be liable if it negligently failed to discover such flaw. If the defect were visible, an inference of negligence would arise from the failure of defendant to discover it.

Where defects are discoverable, it may be assumed that they will not ordinarily escape detection if a reasonable inspection is made, and if such a defect is overlooked an inference arises that a proper inspection was not made. A difficult problem is presented where the defect is unknown and consequently might have been one not discoverable by a reasonable, practicable inspection. In the *Honea* case we refused to take judicial notice of the technical practices and information available to the bottling industry for finding defects which cannot be seen. In the present case, however, we are supplied with evidence of the standard methods used for testing bottles.

A chemical engineer for the Owens-Illinois Glass Company and its Pacific Coast subsidiary, maker of Coca Cola bottles, explained how glass is manufactured and the methods used in testing and inspecting bottles. He testified that his company is the largest manufacturer of glass containers in the United

States, and that it uses the standard methods for testing bottles recommended by the glass containers association. A pressure test is made by taking a sample from each mold every three hours—approximately one out of every 600 bottles—and subjecting the sample to an internal pressure of 450 pounds per square inch, which is sustained for one minute. (The normal pressure in Coca Cola bottles is less than 50 pounds per square inch.) The sample bottles are also subjected to the standard thermal shock test. The witness stated that these tests are ‘pretty near’ infallible.

It thus appears that there is available to the industry a commonly-used method of testing bottles for defects not apparent to the eye, which is almost infallible. Since Coca Cola bottles are subjected to these tests by the manufacturer, it is not likely that they contain defects when delivered to the bottler which are not discoverable by visual inspection. Both new and used bottles are filled and distributed by defendant. The used bottles are not again subjected to the tests referred to above, and it may be inferred that defects not discoverable by visual inspection do not develop in bottles after they are manufactured. Obviously, if such defects do *461 occur in used bottles there is a duty upon the bottler to make appropriate tests before they are refilled, and if such tests are not commercially practicable the bottles should not be re-used. This would seem to be particularly true where a charged liquid is placed in the bottle. It follows that a defect which would make the bottle unsound could be discovered by reasonable and practicable tests.

Although it is not clear in this case whether the explosion was caused by an excessive charge or a defect in the glass there is a sufficient showing that neither cause would ordinarily have been present if due care had been used. Further, defendant had exclusive control over both the charging and inspection of the bottles. Accordingly, all the requirements necessary to entitle plaintiff to rely on the doctrine of *res ipsa loquitur* to supply an inference of negligence are present.

It is true that defendant presented evidence tending to show that it exercised considerable precaution by carefully regulating and checking the pressure in the bottles and by making visual inspections for defects in the glass at several stages during the bottling process. It is well settled, however, that when a defendant produces evidence to rebut the inference of negligence which arises upon application of the doctrine of *res ipsa loquitur*, it is ordinarily a question of fact for the jury to determine whether the inference has been dispelled. ...

The judgment is affirmed. SHENK, CURTIS, CARTER, and SCHAUER, JJ., concurred. EDMONDS, J, dissenting. Rehearing denied.

TRAYNOR, Justice, concurring.

I concur in the judgment, but I believe the manufacturer’s negligence should no longer be singled out as the basis of a plaintiff’s right to recover in cases like the present one. In my opinion it should now be recognized that a manufacturer incurs an absolute liability when an article that he has placed on the market, knowing that it is to be used without inspection, proves to have a defect that causes injury to human beings. *MacPherson v. Buick Motor Co.*, 217 N.Y. 382, established the principle, recognized by this court, that irrespective of privity of contract, the manufacturer is responsible *462 for an injury caused by such an article to any person who comes in lawful contact with it. [***] In these cases the source of the manufacturer’s liability was his negligence in the manufacturing process or in the inspection of component parts supplied by others.

Even if there is no negligence, however, public policy demands that responsibility be fixed wherever it will most effectively reduce the hazards to life and health inherent in defective products that reach the market. It is evident that the manufacturer can anticipate some hazards and guard against the recurrence of others, as the public cannot. Those who suffer injury from defective products are unprepared to meet its consequences. The cost of an injury and the loss of time or health may be an overwhelming misfortune to the person injured, and a needless one, for the risk of injury can be insured by the manufacturer and distributed among the public as a cost of doing business. It is to the public interest to discourage the marketing of products having defects that are a menace to the public. If such products nevertheless find their way into the market it is to the public interest to place the responsibility for whatever injury they may cause upon the manufacturer, who, even if he is not negligent in the manufacture of the product, is responsible for its reaching the market. However intermittently such injuries may occur and however haphazardly they may strike, the risk of their occurrence is a constant risk and a general one. Against such a risk there should be general and constant protection and the manufacturer is best situated to afford such protection.

The injury from a defective product does not become a matter of indifference because the defect arises from causes other than the negligence of the manufacturer, such as negligence of a submanufacturer of a component part whose defects could not be revealed by inspection [***] or unknown causes that even by the device of *res ipsa loquitur* cannot be classified as negligence of the manufacturer. The inference of negligence may be dispelled by an affirmative showing of proper care. If the evidence against the fact inferred *463 is 'clear, positive, uncontradicted, and of such a nature that it can not rationally be disbelieved, the court must instruct the jury that the nonexistence of the fact has been established as a matter of law.' *Blank v. Coffin*, 20 Cal.2d 457, 461. An injured person, however, is not ordinarily in a position to refute such evidence or identify the cause of the defect, for he can hardly be familiar with the manufacturing process as the manufacturer himself is. In leaving it to the jury to decide whether the inference has been dispelled, regardless of the evidence against it, the negligence rule approaches the rule of strict liability. It is needlessly circuitous to make negligence the basis of recovery and impose what is in reality liability without negligence. If public policy demands that a manufacturer of goods be responsible for their quality regardless of negligence there is no reason not to fix that responsibility openly.

In the case of foodstuffs, the public policy of the state is formulated in a criminal statute. Section 26510 of the Health and Safety Code, St.1939, p. 989, prohibits the manufacturing, preparing, compounding, packing, selling, offering for sale, or keeping for sale, or advertising within the state, of any adulterated food. Section 26470, St.1941, p. 2857, declares that food is adulterated when 'it has been produced, prepared, packed or held under insanitary conditions whereby it may have become contaminated with filth, or whereby it may have been rendered diseased, unwholesome or injurious to health.' The statute imposes criminal liability not only if the food is adulterated, but if its container, which may be a bottle (§ 26451, St.1939, p. 983), has any deleterious substance (§ 26470(6), or renders the product injurious to health (§ 26470(4)). The criminal liability under the statute attaches without proof of fault, so that the manufacturer is under the duty of ascertaining whether an article manufactured by him is safe. *People v. Schwartz*, 28 Cal.App.2d Supp. 775. Statutes of this kind result in a strict liability of the manufacturer in tort to the member of the public injured. [***]

The statute may well be applicable to a bottle whose defects cause it to explode. In any event it is significant that the statute imposes criminal liability without fault, reflecting the public policy of

protecting the public from dangerous products placed on the market, irrespective of negligence in their manufacture. While the Legislature imposes criminal liability *464 only with regard to food products and their containers, there are many other sources of danger. It is to the public interest to prevent injury to the public from any defective goods by the imposition of civil liability generally.

The retailer, even though not equipped to test a product, is under an absolute liability to his customer, for the implied warranties of fitness for proposed use and merchantable quality include a warranty of safety of the product [***] The courts recognize, however, that the retailer cannot bear the burden of this warranty, and allow him to recoup any losses by means of the warranty of safety attending the wholesaler's or manufacturer's sale to him. *Ward v. Great Atlantic & Pacific Tea Co.*, supra; see Waite, *Retail Responsibility and Judicial Law Making*, 34 Mich. L. Rev. 494, 509. Such a procedure, however, is needlessly circuitous and engenders wasteful litigation. Much would be gained if the injured person could base his action directly on the manufacturer's warranty.

The liability of the manufacturer to an immediate buyer injured by a defective product follows without proof of negligence from the implied warranty of safety attending the sale. Ordinarily, however, the immediate buyer is a dealer who does not intend to use the product himself, and if the warranty of safety is to serve the purpose of protecting health and safety it must give rights to others than the dealer. In the words *465 of Judge Cardozo in the *MacPherson* case [217 N.Y. 382,]: 'The dealer was indeed the one person of whom it might be said with some approach to certainty that by him the car would not be used. Yet the defendant would have us say that he was the one person whom it was under a legal duty to protect. The law does not lead us to so inconsequent a conclusion.' While the defendant's negligence in the *MacPherson* case made it unnecessary for the court to base liability on warranty, Judge Cardozo's reasoning recognized the injured person as the real party in interest and effectively disposed of the theory that the liability of the manufacturer incurred by his warranty should apply only to the immediate purchaser. It thus paves the way for a standard of liability that would make the manufacturer guarantee the safety of his product even when there is no negligence.

This court and many others have extended protection according to such a standard to consumers of food products, taking the view that the right of a consumer injured by unwholesome food does not depend 'upon the intricacies of the law of sales' and that the warranty of the manufacturer to the consumer in absence of privity of contract rests on public policy. [***] Dangers to life and health inhere in other consumers' goods that are defective and there is no reason to differentiate them from the dangers of defective food products. [***]

In the food products cases the courts have resorted to various fictions to rationalize the extension of the manufacturer's warranty to the consumer: that a warranty runs with the chattel; that the cause of action of the dealer is assigned to the consumer; that the consumer is a third party beneficiary of the manufacturer's contract with the dealer. They have also held the manufacturer liable on a mere fiction of negligence: *466 'Practically he must know it [the product] is fit, or take the consequences, if it proves destructive.' [***] Such fictions are not necessary to fix the manufacturer's liability under a warranty if the warranty is severed from the contract of sale between the dealer and the consumer and based on the law of torts [cc] As the court said in *Greco v. S. S. Kresge Co.*, supra [277 N.Y. 26], 'Though the action may be brought solely for the breach of the implied warranty, the breach is a wrongful act, a default, and, in its essential nature, a tort.' [c]

As handicrafts have been replaced by mass production with its great markets and transportation facilities, the close relationship between the producer and consumer of a product has been altered. Manufacturing processes, frequently valuable secrets, are ordinarily either inaccessible to or beyond the ken of the general public. The consumer no longer has means or skill enough to investigate for himself the soundness of a product, even when it is not contained in a sealed package, and his erstwhile vigilance has been lulled by the steady efforts of manufacturers to build up confidence by advertising and marketing devices such as trade-marks. See *Thomas v. Winchester*, 6 N.Y. 397; *Baxter v. Ford Motor Co.*, 168 Wash. 456; [cc].

Consumers no longer approach products warily but accept them on faith, relying on the reputation of the manufacturer or the trade mark. See [cc] Schechter, *The Rational Basis of Trade Mark Protection*, 40 Harv.L.Rev. 813, 818. Manufacturers have sought to justify that faith by increasingly high standards of inspection and a readiness to make good on defective products by way of replacements and refunds. The manufacturer's obligation to the consumer must keep pace with the changing relationship between them; it cannot be escaped because the marketing of a product has become so complicated as to require one or more *468 intermediaries. Certainly there is greater reason to impose liability on the manufacturer than on the retailer who is but a conduit of a product that he is not himself able to test.

The manufacturer's liability should, of course, be defined in terms of the safety of the product in normal and proper use, and should not extend to injuries that cannot be traced to the product as it reached the market.

Note 1. Why isn't the availability of *res ipsa loquitur* enough, in Justice Traynor's view, to solve the pressing public policy concerns around defective products?

Note 2. The majority opinion follows a "formalist" approach: it uses the doctrine of *res ipsa loquitur* and existing tools and rules and arrives at an outcome for the plaintiff. Generally doing so, however, might require a court to consider custom evidence from the bottling industry, expert evidence on that topic, witness testimony on the handling of the bottle during its entire life cycle, and extensive factual accounts from all the possible parties and their witnesses. Justice Traynor's concurrence reflects impatience with this means of resolving the problem, even if he approves of the outcome.

Recall how in *Coca-Cola Bottling Works v. Lyons* (the Mississippi case), the court noted that it *could* use a theory of joint ownership, or a theory that soda was a gift whose title "ran" with the object. The court appeared to be stating how it could circumvent the privity requirement, and how a *formalist* approach, using the law's formal rules *could technically* permit recovery. Instead, however, the court grounded its holding in a *functionalist* approach that used substantive tort principles (rather than technical rules) to find that recovery should be allowed *even without formal* privity. Traynor's concurrence here displays that same commitment to functionalizing tort law. He states that "[i]n the food products cases the courts have resorted to various fictions to rationalize the extension of the manufacturer's warranty." By characterizing these tactics as "fictions," Traynor is critiquing courts that use and contort formal rules, simply because they are *possible* means of resolution (like the joint ownership theory in *Lyons*), when they are not the best or the rational means to use. Traynor would have preferred the functionalist reasoning of the *Lyons* court's ultimate holding and rationale. In his view, the proper course of action was to allow function, rather than form, to dictate the legal analysis and outcome.

Note 3. Identify at least two of Justice Traynor's policy arguments. Why is he concurring rather than dissenting? Why do you imagine that he was concurring, rather than assigned to write the majority opinion? This concurrence is one of the most famous opinions in 20th century tort law, which is somewhat unusual for a concurring opinion. It is widely thought to have paved the way for strict liability in products liability cases. In the next case, decided nearly two decades later, Justice Traynor writes for the majority, building on his concurrence in *Escola*.

Chapter 28. Strict Products Liability

Greenman v. Yuba Power Products, Inc., Supreme Court of California (1963) (59 Cal.2d 57)

Plaintiff brought this action for damages against the retailer and the manufacturer of a Shopsmith, a combination power tool that could be used as a saw, drill, and wood lathe. He saw a Shopsmith demonstrated by the retailer and studied a brochure prepared by the manufacturer. He decided he wanted a Shopsmith for his home workshop, and his wife bought and gave him one for Christmas in 1955. In 1957 he bought the necessary attachments to use the Shopsmith as a lathe for turning a large piece of wood he wished to make into a chalice. After he had worked on the piece of wood several times without difficulty, it suddenly flew out of the machine and struck him on the forehead, inflicting serious injuries. About ten and a half months later, he gave the retailer and the manufacturer written notice of claimed breaches of warranties and filed a complaint against them alleging such breaches and negligence.

After a trial before a jury, the court ruled that there was no evidence that the retailer was negligent or had breached any express warranty and that the manufacturer was not liable for the breach of any implied warranty. Accordingly, it submitted to the jury only the cause of action alleging breach of implied warranties against the retailer and the causes of action alleging negligence and breach of express warranties against the manufacturer. The jury returned a verdict for the retailer against plaintiff and for plaintiff against the manufacturer in the amount of \$65,000. The trial court denied the manufacturer's motion for a new trial and *60 entered judgment on the verdict. The manufacturer and plaintiff appeal. Plaintiff seeks a reversal of the part of the judgment in favor of the retailer, however, only in the event that the part of the judgment against the manufacturer is reversed.

Plaintiff introduced substantial evidence that his injuries were caused by defective design and construction of the Shopsmith. His expert witnesses testified that inadequate set screws were used to hold parts of the machine together so that normal vibration caused the tailstock of the lathe to move away from the piece of wood being turned permitting it to fly out of the lathe. They also testified that there were other more positive ways of fastening the parts of the machine together, the use of which would have prevented the accident. The jury could therefore reasonably have concluded that the manufacturer negligently constructed the Shopsmith. The jury could also reasonably have concluded that statements in the manufacturer's brochure were untrue, that they constituted express warranties, and that plaintiff's injuries were caused by their breach. The manufacturer contends, however, that plaintiff did not give it notice of breach of warranty within a reasonable time and that therefore his cause of action for breach of warranty is barred by section 1769 of the Civil Code. Since it cannot be determined whether the verdict against it was based on the negligence or warranty cause of action or both, the manufacturer concludes that the error in presenting the warranty cause of action to the jury was prejudicial.

Section 1769 of the Civil Code provides: "In the absence of express or implied agreement of the parties, acceptance of the goods by the buyer shall not discharge the seller from liability in damages or other legal remedy for breach of any promise or warranty in the contract to sell or the sale. But, if after

acceptance of the goods, the buyer fails to give notice to the seller of the breach of any promise or warranty within a reasonable time after the buyer knows, or ought to know of such breach, the seller shall not be liable therefor.” [***] *61

The notice requirement of section 1769, however, is not an appropriate one for the court to adopt in actions by injured consumers against manufacturers with whom they have not dealt. [***] “As between the immediate parties to the sale, [the notice requirement] is a sound commercial rule, designed to protect the seller against unduly delayed claims for damages. As applied to personal injuries, and notice to a remote seller, it becomes a booby-trap for the unwary. The injured consumer is seldom ‘steeped in the business practice which justifies the rule,’ [***] and at least until he has had legal advice it will not occur to him to give notice to one with whom he has had no dealings.” (Prosser, *Strict Liability to the Consumer*, 69 *Yale L.J.* 1099, 1130, footnotes omitted.)

It is true that in [earlier California cases] the court assumed that notice of breach of warranty must be given in an action by a consumer against a manufacturer. Since in those cases, however, the court did not consider the question whether a distinction exists between a warranty based on a contract between the parties and one imposed on a manufacturer not in privity with the consumer, the decisions are not authority for rejecting the rule. [cc]

We conclude, therefore, that even if plaintiff did not give timely notice of breach of warranty to the manufacturer, his cause of action based on the representations contained in the brochure was not barred. Moreover, to impose strict liability on the manufacturer under the circumstances of this case, it was not necessary for plaintiff to establish an express warranty as defined in section 1732 of the Civil Code. A manufacturer is strictly liable in tort when an article he places on the market, knowing that it is to be used without inspection for defects, proves to have a defect that causes injury to a human being. Recognized first in the case of unwholesome food products, such liability has now been extended to a variety of other products that create as great or greater hazards if defective. (*Peterson v. Lamb Rubber Co.*, 54 *Cal.2d* 339, 347 (grinding wheel); *Vallis v. Canada Dry Ginger Ale, Inc.*, 190 *Cal.App.2d* 35, 42-44 (bottle); *Jones v. Burgermeister Brewing Corp.*, 198 *Cal.App.2d* 198, 204 (bottle); *Gottsdanker v. Cutter Laboratories*, 182 *Cal.App.2d* App.2d 602, 607 (vaccine); *McQuaide v. Bridgport Brass Co.*, D.C., 190 *F.Supp.* 252, 254 (insect spray); *Bowles v. Zimmer Manufacturing Co.*, 7 *Cir.*, 277 *F.2d* 868, 875 (surgical pin); *Thompson v. Reedman*, D.C., 199 *F.Supp.* 120, 121 (automobile); *Chapman v. Brown*, D.C., 198 *F.Supp.* 78, 118, 119, *affd.* *Brown v. Chapman*, 9 *Cir.*, 304 *F.2d* 149 (skirt); *B. F. Goodrich Co. v. Hammond*, 10 *Cir.*, 269 *F.2d* 501, 504 (automobile tire); *Markovich v. McKesson and Robbins, Inc.*, 106 *Ohio App.* 265 *63 (home permanent); *Graham v. Bottenfield’s Inc.*, 176 *Kan.* 68 (hair dye); *General Motors Corp. v. Dodson*, 47 *Tenn.App.* 438, 661 (automobile); *Henningsen v. Bloomfield Motors, Inc.*, 32 *N.J.* 358 (automobile); *Hinton v. Republic Aviation Corporation*, D.C., 180 *F.Supp.* 31, 33 (airplane).)

Although in these cases strict liability has usually been based on the theory of an express or implied warranty running from the manufacturer to the plaintiff, the abandonment of the requirement of a contract between them, the recognition that the liability is not assumed by agreement but imposed by law [***], and the refusal to permit the manufacturer to define the scope of its own responsibility for defective products [***], make clear that the liability is not one governed by the law of contract warranties but by the law of strict liability in tort. Accordingly, rules defining and governing warranties that were developed to meet the needs of commercial transactions cannot properly be invoked to govern

the manufacturer's liability to those injured by their defective products unless those rules also serve the purposes for which such liability is imposed.

We need not recanvass the reasons for imposing strict liability on the manufacturer. They have been fully articulated in the cases cited above. (See also 2 Harper and James, Torts, ss 28.15-28.16, pp. 1569-1574; Prosser, Strict Liability to the Consumer, 69 Yale L.J. 1099; *Escola v. Coca Cola Bottling Co.*, 24 Cal.2d 453, 461, concurring opinion.) The purpose of such liability is to ensure that the costs of injuries resulting from defective products are borne by the manufacturers that put such products on the market rather than by the injured persons who are powerless to protect themselves. Sales warranties serve this purpose *64 fitfully at best. (See Prosser, Strict Liability to the Consumer, 69 Yale L.J. 1099, 1124-1134.) In the present case, for example, plaintiff was able to plead and prove an express warranty only because he read and relied on the representations of the Shopsmith's ruggedness contained in the manufacturer's brochure. Implicit in the machine's presence on the market, however, was a representation that it would safely do the jobs for which it was built.

Under these circumstances, it should not be controlling whether plaintiff selected the machine because of the statements in the brochure, or because of the machine's own appearance of excellence that belied the defect lurking beneath the surface, or because he merely assumed that it would safely do the jobs it was built to do. It should not be controlling whether the details of the sales from manufacturer to retailer and from retailer to plaintiff's wife were such that one or more of the implied warranties of the sales act arose. [cc] "The remedies of injured consumers ought not to be made to depend upon the intricacies of the law of sales." [***] To establish the manufacturer's liability it was sufficient that plaintiff proved that he was injured while using the Shopsmith in a way it was intended to be used as a result of a defect in design and manufacture of which plaintiff was not aware that made the Shopsmith unsafe for its intended use.

... The judgment is affirmed.

Note 1. What is the holding in this case? How does Justice Traynor build on and extend the concurrence he authored in *Escola v. Coca Cola Bottling (supra* under Express Warranty)?

Note 2. Why does Justice Traynor find that Greenman's failure to provide timely notice should not bar his breach of warranty claim against the manufacturer?

Note 3. In what way was the Shopsmith potentially defectively constructed?

Note 4. The jury was presented with theories of negligent construction as well as breach of express warranties. The manufacturer argued on appeal that the jury verdict might have been decided due to the breach of warranty claim which (it asserted) was time-barred. Traynor decided that it was irrelevant which theory of liability had persuaded the jury. Why?

Check Your Understanding (5-1)

Question 1. True or false: The legal reasoning in *Coca Cola v. Lyons* provided an example of formalism, rather than functionalism.

An interactive H5P element has been excluded from this version of the text. You can view it online here: <https://saidtorts2d.lawbooks.cali.org/?p=83#h5p-105>

Question 2. Which of the following arguments are inconsistent with the views of Justice Traynor on product liability law?

An interactive H5P element has been excluded from this version of the text. You can view it online here: <https://saidtorts2d.lawbooks.cali.org/?p=83#h5p-106>

The question was aimed at distinguishing consistent views in favor of expanding liability from a theory under which one might shrink liability instead (namely, that liability should not attach if the risks are low or infrequent or unforeseeable, or all of the above). The distinction is important partly because it reflects the schism in products liability law between strict liability (Traynor's aspirations) and negligence (which is what *much* of the law in this area eventually returned to as a standard, with the exceptions of manufacturing defect, express warranty, or any jurisdiction-specific rules creating strict liability). Some jurisdictions no longer allow strict liability for products liability cases at all.

Chapter 29. Product Liability Based on Dangerous or Defective Condition

Restatement (Second) of Torts: Defective, Unreasonably Dangerous Products

In 1965, The American Law Institute endorsed The Restatement (Second) of Torts § 402(A) which, under certain conditions, imposes strict liability upon a seller or manufacturer of a product who sells “any product in a defective condition **unreasonably dangerous** to the user or consumer...” (emphasis added) for physical harm to the consumer caused by such product. Section 402(A) has since been adopted by the vast majority of states.

§ 402A. Special Liability of Seller of Product for Physical Harm to User or Consumer

(1) One who sells any product **in a defective condition** unreasonably dangerous to the user or consumer or to his property is subject to liability for physical harm thereby caused to the ultimate user or consumer, or to his property, if

- (a) the seller is engaged in the business of selling such a product, and
- (b) it is expected to and does reach the user or consumer without substantial change in the condition in which it is sold.

(2) The rule stated in Subsection (1) applies although

- (a) the seller has exercised all possible care in the preparation and sale of his product, and
- (b) the user or consumer has not bought the product from or entered into any contractual relation with the seller.

Note 1. In Section 402A(1), what does “a defective condition unreasonably dangerous to the user” mean? Can a defective condition escape legal consequences for its manufacturer or seller if it is only *reasonably* dangerous? Who do you think is likely to decide what constitutes a defective condition? Who would you think is likely to decide whether the defect is reasonably versus unreasonably dangerous? Why do you think that is so? What sorts of evidence might be used to prove defectiveness, dangerousness and reasonableness, respectively?

Note 2. Would it surprise you to learn that the phrase, as adopted in most jurisdictions, expressly omits the word “unreasonably”? The standard is often stated thus: “defective condition dangerous to the user.” Why do you think that might be?

Note 3. How do Sections 402A(1)(a) and (b) **limit** the scope of liability? What do you imagine are the real-world effects of such provisions?

Note 4. How do Sections 402A(2)(a) and (b) **expand** the scope of liability? What is the practical legal effect of each of those provisions?

A Categorical Approach to Liability for Defective Products

In addition to § 402(A), The American Law Institute adopted Restatement (Third) of Torts §§ 1 & 2 in 1998. These newer sections impose liability upon commercial sellers and distributors for harm caused by defective products, and delineate categories of “product defect.” Sections 1 & 2 have been controversial due partly to their use of the reasonable alternative design (as an apparent requirement *imposed on* the plaintiff rather than a theory of liability and admissible evidence *available for* the plaintiff).

The relevant volume of the Restatement (Third) of Torts sets out three types of defects that may render a product “unreasonably dangerous”: manufacturing defect; design defect; and defective (or inadequate) warning.

Restatement (Third) of Torts: Products Liability (1998)

§ 1. Liability of Commercial Seller or Distributor for Harm Caused by Defective Products

One engaged in the business of selling or otherwise distributing products who sells or distributes a defective product is subject to liability for harm to persons or property caused by the defect.

§ 2. Categories of Product Defect

A product is defective when, at the time of sale or distribution, it contains a manufacturing defect, is defective in design, or is defective because of inadequate instructions or warnings.

A product:

- (a) contains a **manufacturing defect** when the product departs from its intended design even though all possible care was exercised in the preparation and marketing of the product;
- (b) is **defective in design** when the foreseeable risks of harm posed by the product could have been reduced or avoided by the adoption of a reasonable alternative design by the seller or other distributor, or a predecessor in the commercial chain of distribution, and the omission of the alternative design renders the product not reasonably safe;
- (c) is **defective because of inadequate instructions or warnings** when the foreseeable risks of harm posed by the product could have been reduced or avoided by the provision of reasonable instructions or warnings by the seller or other distributor, or a predecessor in the commercial chain of distribution, and the omission of the instructions or warnings renders the product not reasonably safe.

Contemporary case law has widely adopted this categorical approach as the cases in this section of the book illustrate. A particular unit of a product may be defective because of an imperfection in the manufacturing process. (*Ford Motor Co. v. Ledesma*, 242 S.W.3d 32 (Tex. 2007). Additionally, a product’s design may render the item “unreasonably dangerous.” *Ford Motor Co. v. Trejo*, 133 Nev. 520 (2017). Finally, a failure to post adequate warnings may deem a product “unreasonably dangerous.” *Shinedling v. Sunbeam Products, Inc.*, U.S. Dist. Court, C.D. Cal. (2014) (2014 WL 12589646).

Exam Tip: When facing a products liability fact pattern, you will need to identify what sort of defect, if any, exists, before you can identify which liability regime will apply.

Manufacturing Defects

Ford Motor Co. v. Ledesma, Supreme Court of Texas (2007) (242 S.W.3d 32)

In this products liability case, Ford Motor Co. argues that the trial court reversibly erred in charging the jury by giving an incomplete definition of “manufacturing defect.” We agree. [***] We remand the case for a new trial under a jury charge that reflects our applicable caselaw, including our decision today. In March 1999, Tiburicio Ledesma, Jr. purchased a new Ford F-350 Super Duty pickup truck for his construction business. The truck had four rear tires, two on each side, surrounded by fiberglass fenders extending beyond the sides of the truck.

On June 5, 1999, Ledesma turned onto a two-lane street in Austin and began to accelerate. He testified that after shifting gears the truck suddenly began to lurch, and he lost control, striking two parked cars, a Firebird and a Civic, on the side of the street. The truck then hit the street curb and came to rest. At the time of the accident, the truck’s odometer read about 4,100 miles. Power from the truck engine is conveyed to the rear axle by the drive shaft, which connects the transmission in the front of the truck with the differential/rear axle assembly in the rear. As seen in the trial exhibit reproduced below, the rear-axle housing is attached to two sets of rear leaf springs by u-bolts, which wrap around the axle housing and are bolted to a rear spring plate that sits on top of the leaf-spring assembly. On each side of the truck, two u-bolts attach the rear-axle housing to a spring plate and set of leaf springs.

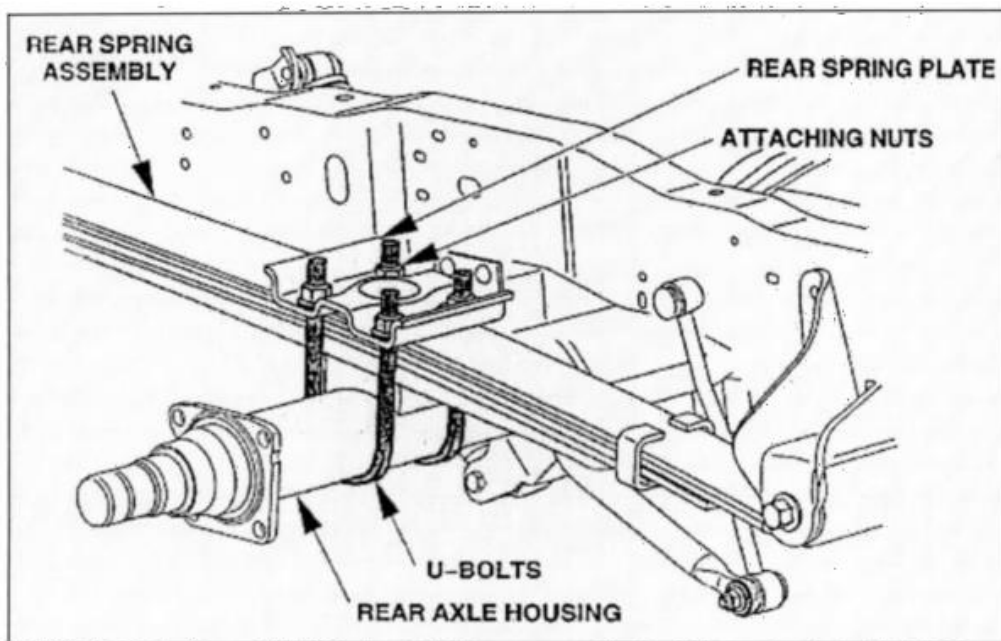

Both parties agree that the truck's rear leaf spring and axle assembly came apart and that this separation caused the drive shaft to dislodge from the transmission. The core dispute centers on *when* and *why* this malfunction occurred and whether it *caused* the collision or *resulted* from it. That is, did a manufacturing defect trigger the right rear-axle displacement and cause Ledesma to lose control of the truck and strike the parked cars (as Ledesma claims), or did the right rear axle detach when Ledesma struck the parked cars and curb (as Ford claims)?

At trial, Ledesma claimed that he lost control of the truck when its drive shaft separated from the transmission and “pronged” on the pavement, causing him to hit the parked cars. A police officer testified that he investigated the accident scene and prepared a report based on Ledesma's description of the accident. The report makes no mention of any other witnesses. Ledesma also presented two expert witnesses in support of his manufacturing defect claim, as discussed below.

Ford presented an expert, Dan May, in support of its theory that the axle-to-spring attachment failed, not because of a manufacturing defect, but because of the forces exerted on it when Ledesma struck the parked vehicles and curb. Among other efforts to discredit May, Ledesma emphasized to the jury that May was a long-time Ford employee and had never found a defect in a Ford product.

Ford also called the owner of the Firebird, Edward Plyant, who testified by deposition that he witnessed the accident from a driveway. Plyant testified that Ledesma was speeding and inattentive and struck the Firebird at a high rate of speed. Ledesma testified that Plyant did not see the accident, but came outside after hearing the ensuing commotion, and that Plyant had unsuccessfully sued Ledesma.

The jury sided 11–1 with Ledesma, finding that a manufacturing defect caused the accident and that Ledesma was not contributorily negligent, and awarding economic damages of \$215,380. The court of *37 appeals affirmed. [***]

A. Admissibility of Ledesma's Expert Testimony. [discussion omitted]

B. Jury Charge

Ford complains that, over its objection, the trial court improperly instructed the jury on the definitions of manufacturing defect and producing cause. The jury affirmatively answered Question No. 1 of the jury charge, which asked:

Was there a manufacturing defect in the 1999 Ford F–350 pickup truck at the time it left Ford's possession that was a producing cause of the June 5, 1999 incident in question?

A “defect” means a condition of the product that renders it unreasonably dangerous. An “unreasonably dangerous” product is one that is dangerous to an extent beyond that which would be contemplated by the ordinary user of the product, with the ordinary knowledge common to the community as to the product's characteristics.

“Producing cause” means an efficient, exciting, or contributing cause that, in a natural sequence, produces the incident in question. There may be more than one producing cause.

In defining defect, the trial court followed Texas Pattern Jury Charge (PJC) 71.3.¹⁵⁹ As specified in the comment to PJC 71.3, the trial court included in the question the definition of producing cause found in PJC 70.1. Ford objected that both PJC 71.3 and PJC 70.1 were “not accurate under the law” and failed to track this Court’s precedent. We agree. Ledesma may have *argued* a manufacturing defect to the jury, but the law requires the jury to determine specifically whether he had *proven* one. The jury here received a legally incorrect charge that omitted an indispensable element: that the product deviated, in its construction or quality, from its specifications or planned output in a manner that rendered it unreasonably dangerous.

1. The Court’s Charge on Manufacturing Defect Failed to Include the Essential Element of a Deviation from Design

The trial court submitted the pattern jury charge’s definition on manufacturing defect. We agree with Ford, however, that the model charge is erroneous, as it does not include the requirement that a manufacturing defect must deviate from its specifications or planned output in a manner that renders the product unreasonably dangerous. We established this standard in *American Tobacco Co. v. Grinnell* (951 S.W.2d 420, 434 (Tex.1997)) and in three other cases since *Grinnell* was issued a decade ago, we have recognized, with essentially identical statements, the “deviation from specifications or planned output” requirement [Citations omitted]. This *42 requirement is separate from, and in addition to, the requirements that the product was defective when it left the manufacturer and that the defect was a producing cause of the plaintiff’s injuries. [***]

We note that the current Restatement of Torts essentially follows the same concept of a deviation from the manufacturer’s design by providing that a product “contains a manufacturing defect when the product departs from its intended design even though all possible care was exercised in the preparation and marketing of the product...”¹⁶⁰ The requirement of a deviation from the manufacturer’s specifications or planned output serves the essential purpose of distinguishing a manufacturing defect from a design defect. PJC 71.3 refers to a “manufacturing defect” in the product “at the time it left” the manufacturer. A jury—without further guidance—may view any defect in a product at the time it leaves the manufacturer as satisfying the PJC’s reference to a “manufacturing defect,” rather than making the essential distinction between a manufacturing and design defect. As it stood, the court’s charge merely inquired whether a “condition” of the product rendered it unreasonably dangerous. That “condition” could have been a design defect or a manufacturing defect.

The distinction is material. The danger of allowing a jury to conclude that the defect was or might have been a design defect is that “[a] design defect claim requires proof and a jury finding of a safer alternative design.” [fn] The charge did not make such an inquiry.

Moreover, requiring a deviation from specifications or planned output permits a jury to determine whether a specific defect caused the accident, rather than premising liability on a belief that a product failure, standing alone, is enough to find a product defect. Texas law does not generally recognize a product failure or malfunction, standing alone, as sufficient proof of a product defect. [fn] Instead, we have held that “a specific defect must be identified by competent evidence and other possible causes

¹⁵⁹ COMM. ON PATTERN JURY CHARGES, STATE BAR OF TEX., TEXAS PATTERN JURY CHARGES—MALPRACTICE, PREMISES & PRODUCTS PJC 71.3 (2d ed.2002).

¹⁶⁰ RESTATEMENT (THIRD) OF TORTS: PRODUCTS LIABILITY § 2(a) (1998); see also id. § 1 cmt. a (“A manufacturing defect is a physical departure from a product’s intended design.”).

must be ruled out.” [fn] Our law requires more than finding an undifferentiated “condition” that renders the product unreasonably dangerous, which is all the court’s charge mandated. While a products liability claim does not of course require proof of manufacturer negligence, the deviation from design that caused the injury must be identified. Otherwise, the jury is invited to find liability based on speculation as to the cause of the incident in issue.

Requiring proof of a deviation from manufacturer specifications or planned output also comports with our recognition that expert testimony is generally encouraged if not required to establish a products liability claim. [Citations omitted] If juries were *43 generally free to infer a product defect and injury causation from an accident or product failure alone, without any proof of the specific deviation from design that caused the accident, expert testimony would hardly seem essential. Yet we have repeatedly said otherwise.

For these reasons, we hold that the court’s charge was fundamentally flawed in omitting the requirement that the product deviate, in its construction or quality, from its specifications or planned output in a manner that renders it unreasonably dangerous.

Since Ford preserved error, we turn to whether the charge error is reversible. We hold that it is. “It is fundamental to our system of justice that parties have the right to be judged by a jury properly instructed in the law.” [fn] “There can be no question that it was [the plaintiff’s] burden to obtain affirmative answers to jury questions as to the necessary elements of his cause of action.” [fn] The jury was not asked to decide an essential element of a manufacturing defect claim, namely whether the u-bolt deviated from Ford’s specifications or planned output.

[***] In the pending case, the trial court followed the [Pattern Jury Charges (“PJC”)]. On one occasion we not only approved a PJC issue and instruction for design defect cases, we expressly disapproved of the use of any other instructions in such cases, [fn] prompting one court of appeals to remark that “[o]ur highest court has made it abundantly clear that to deviate from the pattern jury charges in products liability cases is a perilous journey.” Given that our trial courts routinely rely on the Pattern Jury Charges in submitting cases to juries,¹⁶¹ and we rarely disapprove of these charges, we conclude that the interests of justice would not be served by reversing and rendering judgment in favor of Ford. The more appropriate remedy is to reverse and remand for a new trial.

Note 1. The court remands with a warning about the “perilous journey” of deviating from pattern jury instructions. If the challenges of instructing juries are so high, and the risks of error so seemingly significant that judges describe the adjudication as “perilous,” does it continue to make sense to allocate so much authority to juries? Can you think of alternatives (in terms of decisional allocation, instructional practice, or doctrinal development)?

Note 2. For your own review and understanding, articulate the difference between a manufacturing defect and a design defect, as you understand it so far. Can you come up with an example of what those might look like in a domain that is familiar to you because of a product you have purchased or routinely purchase?

¹⁶¹ Indeed, Ford’s own brief contends that until this Court corrects the PJC 71.3, “it will continue to be used in every case in Texas in which [a manufacturing] defect is alleged.”

Note 3. What sort of evidence would a plaintiff need to show to prove that *a defect caused the accident* that caused the plaintiff's injury? What sort of evidence might a defendant offer if trying to prove that *the accident caused the product to look defective*?

Check Your Understanding (5-2)

Question 1. *Ford Motor Co. v. Ledesma* articulates the standard for finding a manufacturing defect: “the product [must] deviate, in its construction or quality, from its specifications or planned output in a manner that renders it unreasonably dangerous.” The plaintiff must provide evidence of deviation from design as distinct from manufacturing. Apply that standard to the following hypothetical.

True or false: A new pour-over coffee brewing device, “WydePour” is created with a wide spout to preserve maximum flavor while brewing coffee. Its shape makes spills slightly more likely. A purchaser of WydePour sustains burns when pouring hot coffee into their mug and would like to sue. If any products liability claim is available on the basis of a product defect, the facts suggest that the plaintiff might be able to prove that there was a manufacturing defect but not a design defect.

An interactive H5P element has been excluded from this version of the text. You can view it online here: <https://saidtorts2d.lawbooks.cali.org/?p=86#h5p-107>

Chapter 30. Design Defects (Socratic Script)

Ford Motor Company v. Trejo, Supreme Court of Nevada (2017) (133 Nev. 520)

[***] In 1999, appellant Ford Motor Company introduced the Ford Excursion, the largest and heaviest SUV ever produced and sold in North America. At trial, Ford conceded that it did not perform any physical roof-crush tests on the Excursion. In 2002, Ford ran computer-simulated testing on the Excursion, using modeling that had been developed during the development of the Super Duty pickup trucks [on which the Excursion’s design had been based]. Ford’s internal guidelines required that a vehicle weighing less than 8,500 pounds have a roof strength-to-weight ratio of 1.725 pounds. The strength-to-weight ratio of the Excursion was only 1.25. If the windows *522 were not available to act as added support (e.g., if the windows broke), the strength-to-weight ratio dropped to 0.79. Though the Excursion’s actual weight was 7,730 pounds, its gross vehicle weight rating was 8,600 pounds. Ford did not have internal guidelines for strength-to-weight ratios for vehicles weighing over 8,500 pounds. Therefore, Ford did not issue any recalls on the Excursion, or otherwise advise dealerships or the public that early versions of the Excursion did not meet Ford’s internal guidelines for roof strength.

On December 16, 2009, respondent Teresa Trejo, a resident of Las Vegas, was driving a 2000 Ford Excursion, with a trailer attached, through New Mexico. Her husband Rafael Trejo was seated in the passenger seat. While driving on the highway, Trejo attempted to change lanes to make room for merging traffic. The trailer attached to the Excursion started to fishtail. Trejo swerved, and though the Excursion slowed, it began to roll, somewhere between 1.5 and 2.5 times.

After the rollover sequence, the Excursion came to rest upside down. Trejo managed to remove her seatbelt and exit the Excursion through the driver’s side window. She went to the passenger side of the vehicle, but the roof was so crushed that Trejo was unable to see Rafael. She returned to look through the driver’s side window. Trejo saw Rafael, who could not move but was looking back at her. Trejo later testified that Rafael’s eyes were moving at this time. A couple driving by assisted Trejo in removing Rafael from the vehicle. Emergency services arrived shortly thereafter and confirmed that Rafael had died.

Trejo subsequently filed a complaint against Ford, alleging a design defect in the roof of the Excursion and seeking damages based on twin theories of strict products liability and common law negligence. The case proceeded to trial solely on the strict products liability theory. During trial, Trejo presented expert testimony to support her theory of “hyperflexion”—that the roof of the Excursion crushed, breaking and pinning Rafael’s neck, and causing him to suffocate. Trejo also presented evidence that Ford could have reinforced the roof of the Excursion for an additional \$70 in production costs, adding an additional 70 pounds of weight to the Excursion.

Ford presented evidence supporting its theory of “torso augmentation”—that Rafael died during the first rollover, because the moment the Excursion turned upside down, the weight of Rafael’s body “diving” into the roof caused his neck to break, killing him instantly. *523 Ford also disputed the feasibility of Trejo’s proposed reinforcement to the roof design of the Excursion.

While settling jury instructions, Ford requested the district court to give design defect instructions based on the “risk-utility” test set forth in the Third Restatement.¹⁶² To this end, Ford requested Instruction nos. 21, 22, and 23. The parties also provided the district court with agreed upon alternatives to these instructions, nos. 21A, 22A, and 23A, in the event the court declined to adopt the Third Restatement. Noting that Nevada has not adopted the Third Restatement approach to claims of design defect, the district court declined to give Ford’s requested instructions. The district court instead gave the parties their *agreed-upon* alternatives which were stock instructions and reflected the current state of the law.

Ultimately, the jury returned a special verdict in favor of Trejo, answering in the affirmative the following two questions: (1) whether the 2000 Ford Excursion’s roof was defective in design, and, if so, (2) whether the 2000 Ford Excursion’s roof design defect was a proximate cause of Rafael Trejo’s death. The district court entered judgment on the jury’s \$4.5 million damages award and granted in part and denied in part Ford’s subsequent motion to relax costs. Ford filed a motion for judgment as a matter of law or for a new trial, which the district court denied. Ford now appeals.

To determine whether a product is defective in its design under strict tort liability, Nevada has long used the consumer-expectation test. *Ginnis v. Mapes Hotel Corp.*, 86 Nev. 408, 413(1970). Under the consumer expectation test, a plaintiff must demonstrate that a product “failed to perform in the manner reasonably to be expected in light of its nature and intended function and was more dangerous than would be contemplated by the ordinary user having the ordinary knowledge available in the community.” [c]

In 1998, the drafters of the Third Restatement proposed the risk-utility test for strict product liability design defect claims. Under this test, a product “is defective in design when the foreseeable risks of harm posed by the product could have been reduced or avoided by the adoption of a reasonable alternative design ... and the omission of the alternative design renders the product not reasonably safe.” *524 Restatement (Third) of Torts: Prods. Liab. § 2(b) (Am. Law Inst. 1998). Thus, under the risk-utility test, in addition to proving elements of negligence, plaintiffs also bear the new burden of proving a “reasonable alternative design.” *Id.*

[***] The risk-utility test, especially its requirement of proof of a reasonable alternative design, would prove fundamentally unfair to Nevada plaintiffs. Instead of being allowed to bolster their case with evidence of an alternative design after the discovery process, a plaintiff would face the barrier of establishing a reasonable alternative design from the outset, even in those cases where no reasonable design may exist, or where the defendant is in complete control of the necessary information related to product design. Because we further conclude that Trejo presented sufficient evidence of design defect under the consumer-expectation test and causation, we affirm the judgment of the district court. [c]

In 1966, this court examined a case in which Leo Dolinski purchased a bottle of Squirt soda from a vending machine, took a drink, and discovered the remains of a decomposing mouse. *Shoshone Coca-Cola Bottling Co. v. Dolinski*, 82 Nev. 439, 441 (1966). Dolinski presented his case to the jury solely on the theory of strict product liability, and the jury awarded Dolinski \$2,500 in damages. In affirming

¹⁶² The dissent conflates Ford’s requested instructions, which change the standard under which a plaintiff must prove a design defect, with instructions that may assist a jury on how to use relevant information. Ford only proffered instructions on the former, and once denied by the district court, agreed to the instructions given and sought no further clarifications to assist the jury with the latter.

the jury's verdict, this court determined that when a manufacturer has placed a dangerous or defective product into the stream of commerce, sound public policy requires the imposition of strict liability, even in those situations where "the seller has exercised all reasonable care, and the user has not entered into a contractual relation with him." [***]

Nonetheless, this court cautioned that while a manufacturer and distributor of a bottled beverage may be strictly liable without a showing of negligence or privity, the adoption of strict tort liability as a theory of recovery "does not mean that the plaintiff is relieved of the burden of proving a case." *Id.* at 443. Rather, this court noted that a plaintiff was required to demonstrate that (1) the product at issue was defective, (2) the defect existed at the time the product left the manufacturer, and (3) the defect caused the plaintiff's injury. [c]

Four years later in *Ginnis*, this court extended the doctrine of strict tort liability "to the design and manufacture of all types of products." 86 Nev. at 413. With respect to proving whether a product is defective, this court also adopted the consumer-expectation test, which is set forth in Section 402A of the Restatement (Second) of Torts (Am. Law Inst. 1965). *Id.* at 414. In adopting the consumer-expectation test in *Ginnis*, this court explained that

[a]lthough the definitions of the term "defect" in the context of products liability law use varying language, all of them rest upon the common premise that those products are defective which are dangerous because they fail to perform in the manner reasonably to be expected in light of their nature and intended function.

Id. at 413 [c]. Further, defective products are "more dangerous than would be contemplated by the ordinary user having the ordinary knowledge available in the community." [c]

This court has subsequently recognized three categories of strict tort liability claims: manufacturing defects, design defects, and the failure to warn. [cc] In the realm of manufacturing and design defects, this court has consistently applied the consumer-expectation test to determine liability. [cc]

In the context of proving that a product was defective under the consumer-expectation test, this court has concluded that "[a]lternative design is one factor for the jury to consider when evaluating *526 whether a product is unreasonably dangerous." [c] Therefore, a plaintiff may choose to support their case with evidence "that a safer alternative design was feasible at the time of manufacture." [c] However, any alternative design presented must be commercially feasible. [***] In addition to evidence of alternative designs, evidence of other accidents involving analogous products, post-manufacture design changes, and post-manufacture industry standards will support a strict product liability claim. [c]

Ford urges this court to depart from this well-settled line of jurisprudence and adopt the risk-utility test for design defects set forth in the Third Restatement. Under the risk-utility test, a product

is defective in design when the foreseeable risks of harm posed by the product could have been reduced or avoided by the adoption of a reasonable alternative design by the seller or other distributor, or a predecessor in the commercial chain of distribution, and the omission of the alternative design renders the product not reasonably safe.

Restatement (Third) of Torts: Prods. Liab. § 2(b) (Am. Law Inst. 1998). The drafters of the Third Restatement provide a number of factors relevant to analyzing whether there was a reasonable

alternative design and whether the omission of the alternative design renders a product not reasonably safe. Some of the factors for consideration include the magnitude and probability of foreseeable risks of harm; the instructions and warnings included with the product; the nature and strength of consumer expectations regarding the product, including expectations arising from product advertising and marketing; the advantages and disadvantages of product function arising from the alternative design, as well as the effects of the alternative design on production costs; and the effects of the alternative design on product longevity, maintenance, repair, and esthetics. *Id.* § 2 cmt. f.

Some analysts of the risk-utility approach have posited that the test is better suited to analyzing cases involving complicated or technical design. These proponents of the risk-utility approach also contend that the average consumer does not have ascertainable “expectations” about the performance of a complex product, such as a car, in unfamiliar circumstances. *See* Douglas A. Kysar, *The Expectations of Consumers*, 103 Colum. L. Rev. 1700, 1716 (2003). *527 Accordingly, adopting courts have observed that when faced with a complicated or technical design, the risk-utility analysis “provides objective factors for a trier of fact to analyze when presented with a challenge to a manufacturer’s design.” *Branham v. Ford Motor Co.*, 390 S.C. 203 (2010).

Based on these perceived advantages, a number of jurisdictions have exclusively adopted the risk-utility analysis in design defect cases through either caselaw or statute. [Collecting cases from Alabama, Georgia, Iowa, Kentucky, Louisiana, Mississippi, Montana and Texas] Still others have adopted a hybrid approach, utilizing the risk-utility approach only in complex design situations. [Citing cases from California and Illinois]

Ford urges this court to join those jurisdictions that have concluded that the risk-utility test better allows a jury to analyze complex cases in which consumer expectations are less clear. Ford also argues that the risk-utility test provides a lay jury with a concrete framework in which to analyze complex or technical products. Despite Ford’s arguments, we find that the proposed advantages of the risk-utility test over the consumer-expectations test are largely overstated. Further, as discussed below, the adoption of negligence standards into strict products liability, as well as the affirmative requirement that plaintiffs provide proof of a reasonable alternative design, stands contrary to the public policy supporting Nevada’s long-standing use of the consumer-expectation test.

With respect to the clarity of consumer expectations, we conclude that even in cases of complex or technical products, a lay jury is sufficiently equipped to determine whether a product performs in a manner to be reasonably expected under certain circumstances, pursuant to the consumer-expectation test. [***]

With respect to the instant case, Ford argues that it is extremely unlikely that the Trejos bought their Excursion with any specific expectation regarding the strength-to-weight ratio of the vehicle roof. Nonetheless, Trejo presented sufficient evidence for the jury to conclude that the level of protection actually provided by the roof in a rollover accident was less than would be expected by a reasonable consumer, indicating that in this case, the distinction between the risk-utility and consumer expectation tests is without practical difference.

Further, to the extent scientific or technical evidence is presented, we note that juries are often requested to digest unfamiliar technical material. [***] “[J]uries are always called upon to make decisions based upon complex facts in many different kinds of litigation. ... The problems presented in products liability jury trials would appear no more insurmountable than similar problems in other

areas of the law.” [cc] Ford presents no evidence that the jury was incapable of digesting the expert testimony and evidence admitted in this case.

[***] In addition to our determination that the proposed benefits of the risk-utility test are overstated, the risk-utility approach also presents several tangible disadvantages. When we first adopted the theory of strict liability in *Shoshone*, this court reasoned that when a seller has advertised a product, and invited and solicited its use, the seller should not be permitted to avoid the consequences of a “disaster” by arguing that he used all reasonable care. 82 Nev. at 442. Accordingly, the consumer-expectation test focuses on the reasonable expectations of a consumer regarding the use and performance of a product. Rather than focus on the product itself, the risk-utility test subverts this analysis, focusing on the “foreseeable risks of harm” apparent to a manufacturer when adopting a design. This inserts a negligence standard into an area of law where this court has intentionally departed from traditional negligence analysis. See *Aubin*, 177 So.3d at 506; [c] (noting that the risk-utility test unnecessarily “blurs the distinction between strict products liability claims and negligence claims”). By focusing on the conduct of the manufacturer in designing and developing, rather than the product itself, the risk-utility test is in direct conflict with the reasoning of this court in *Shoshone* and its progeny.

Further, as noted by the Kansas Supreme Court, the risk-utility test

is impoverished especially insofar as the [drafters of the Third Restatement] ruled out consumer expectations as an independent test. They thereby ignored the centrality of what we all know as people ...: the centrality of product portrayals and images and their role in creating consumer motives to purchase or encounter products.

[cc]. Given the unique position of manufacturers, we agree that by advocating for the negligence-based risk-utility approach, “the Third Restatement fails to consider the crucial link *530 between a manufacturer establishing the reasonable expectations of a product that in turn cause consumers to demand that product.” *Aubin* at 508. [***]

The jury in this case was properly instructed on the consumer-expectation test. Further, the record demonstrates that Trejo presented sufficient evidence to demonstrate that the roof of the Ford Excursion failed to perform in a manner reasonably expected in light of its nature and intended function and was more dangerous than would be contemplated by the ordinary user having the ordinary knowledge available in the community. Trejo also presented evidence sufficient to demonstrate that Rafael Trejo’s death was caused by this defect. Therefore, we affirm the judgment on the jury verdict, as well as the post-judgment order awarding costs.

PICKERING, J., dissenting:

The jury instructions the district court gave and the majority affirms were inadequate. They told the jury to decide this case based solely on “consumer expectations,” that is, on how the jurors thought an “ordinary user having the ordinary knowledge available in the community” would have expected the Excursion’s roof to function in a highway-speed rollover. The district court refused Ford’s request that the court also instruct the jury on whether, based on the expert testimony they heard, a feasible alternative design existed *533 for the roof that would have protected Trejo, who was in the front passenger seat, from being crushed in the rollover.

Neither Nevada law, nor the law nationally, supports deciding a design defect case such as this based solely on consumer expectations. The failure to instruct the jury on alternative design left the jurors with no specific guidance on the law by which to decide the case. While I would not pursue an alternative design or “risk-utility” analysis to the exclusion of consumer expectations—a position the majority erroneously attributes to the Restatement (Third) of Torts: Products Liability (Am. Law Inst. 1998)—the jury can and should be instructed on alternative design in addition to consumer expectations where, as here, evidence has been presented to support it. As this instructional error clouds the verdict’s reliability, I would reverse and remand for a new trial. I therefore dissent.

Nevada imposes strict liability on manufacturers and distributors who place in the hands of users a product that is “unreasonably dangerous.” [c] As the majority notes, there are three principal types of products liability claims: manufacturing defect; design defect; and inadequate warnings. In *Ginnis v. Mapes Hotel Corp.*, 86 Nev. 408, 413 (1970), we endorsed what has come to be known as the consumer expectation test as an appropriate means of assessing “unreasonable dangerousness.” Under this test, the plaintiff must demonstrate that the product “fail[ed] to perform in the manner reasonably to be expected in light of [its] nature and intended function” and “was more dangerous than would be contemplated by the ordinary user having the ordinary knowledge available in the community.” [***] As part of, or in addition to, the consumer expectation test, Nevada has endorsed using the existence of a safer alternative design to prove that a design defect or lack of warnings made a product unreasonably dangerous. *McCourt v. J.C. Penney Co.*, 103 Nev. 101, 102, 104 (1987) (citing *Ginnis* and reversing because the district court erred in refusing, in a design defect case, to admit evidence of feasible alternative design: “Alternative design is one factor for the jury to consider when evaluating whether a product is unreasonably dangerous”); *see also* *534 [***] *Robinson v. G.G.C., Inc.*, 107 Nev. 135, 138 (1991) (“a manufacturer may be liable for the failure to provide a safety device if the inclusion of the device is commercially feasible, will not affect product efficiency, and is within the state of the art at the time the product was placed in the stream of commerce”); [c]. Though not denominated as such by our case law, this balancing of a possible safer alternative design against its commercial feasibility is known as the “risk-utility” approach to determining product defect. *See* 1 David G. Owen & Mary J. Davis, *Owen & Davis on Products Liability* § 8:7 (4th ed. 2014). A risk-utility analysis determines “[w]hether a particular design danger is ‘unreasonable’ (that is, ‘defective’)” by balancing “ ‘the probability and seriousness of harm against the costs of taking precautions. Relevant factors to be considered include the availability of alternative designs, the cost and feasibility of adopting alternative designs, and the frequency or infrequency of injury resulting from the design.’ ” *Id.*

At trial, both sides presented evidence regarding alternative roof designs and their commercial feasibility, as *McCourt* and its progeny allow. Trejo affirmatively alleged that a safer alternative design was available and presented expert testimony that the design was commercially reasonable. Ford presented contradictory evidence, to the effect that Trejo’s expert’s proposed design was not, in fact, safer and, further, created issues of commercial unreasonableness.

Based on this admitted evidence, Ford sought to have the jury instructed on alternative design by adding the italicized language to the stock product-defect jury instruction:

[Proposed] Instruction No. 21

In order to establish a claim of strict liability for a defendant product, the plaintiff must prove the following elements by a preponderance of the evidence:

1. That Ford Motor Company was the manufacturer of the 2000 Ford Excursion;
2. That the 2000 Ford Excursion's roof structure was defectively designed;
3. That the defect existed when the 2000 Ford Excursion left Ford Motor Company's possession;
- *535 4. That the 2000 Ford Excursion was used in a manner which was reasonably foreseeable by Ford Motor Company;
5. *There existed a reasonable alternative design*; and
6. That the defect was a proximate cause of the injury to Rafael Trejo.

(emphasis added to show proposed addition to *Nevada Jury Instructions—Civil* § 7PL.4 (2011)).

Ford also offered [Proposed] Instruction No. 22, as follows:

A product is defective in design when the foreseeable risks of harm posed by the product could have been reduced or avoided by the adoption of a reasonable alternative design and the omission of the alternative design renders the product not reasonably safe.

Although these requested instructions accurately stated Nevada law under *McCourt*, the district court rejected them. It also rejected every other jury instruction Ford proposed that touched on reasonable alternate design.¹⁶³ As a result, the jury received no instructions on how to apply the evidence regarding a safer alternative design and its commercial feasibility to determine whether the Excursion was unreasonably dangerous due to a design defect.

The court gave only stock product liability instructions to the jury. Thus, the district court gave as Instruction No. 19 what Ford had tendered as [Proposed] Instruction No. 21, *minus* the italicized language about reasonable alternative design, *reprinted supra* at 3–4. It also gave, as the only other guidance on how the jury should decide design defect, the following stock instructions:

Instruction No. 20

A product is defective in its design if, as a result of its design, the product is unreasonably dangerous.

¹⁶³ In addition to the instructions reprinted in the text, Ford proposed a “state of the art defense” instruction and, citing *Robinson v. G.G.C., Inc.*, 107 Nev. at 139–40, an instruction that would have told the jury as a minimal alternative that “[a] manufacturer is not required to produce the safest design possible.” Both were refused, as was Ford’s additional proposed instruction based on the Restatement (Third) section 2(b) that would have told the jury that, in assessing risk-utility, to consider “(a) the likelihood that the product will cause injury considering the product as sold with any instructions or warnings regarding its use; (b) the ability of the plaintiff to have avoided injury; (c) the plaintiff’s awareness of the product’s dangers; (d) the usefulness of the product as designed as compared to a safe design; (e) the functional and monetary cost of using the alternative design; and (f) the likely effect of liability for failure to adopt the alternative design on the range of consumer choice among products.

***536** Instruction No. 21

A product is unreasonably dangerous if it failed to perform in the manner reasonably to be expected in light of its nature and intended function, and was more dangerous than would be contemplated by the ordinary user having the ordinary knowledge available in the community.

See Nevada Jury Instructions—Civil § 7PL.7 (2011). While these instructions are accurate, they are incomplete and misleading as a result. “[C]onsumers comprehend that automobiles are not completely crashproof, but they have no meaningful expectations as to the extent to which a vehicle may be compromised in the event of a collision or rollover at substantial speeds.” 1 Owen & Davis, *supra*, at § 8:5. The jury should have been instructed on all of the law pertinent to the evidence presented, including alternative design.

The instructions the jury received failed to give them any guidance on how to utilize the ample expert evidence presented over the course of the two-week trial regarding Trejo’s proffered alternative design and Ford’s arguments that the alternative design was proven neither to be safer nor commercially feasible. *See Woosley v. State Farm Ins. Co.*, 117 Nev. 182, 188 (2001) (providing that it is error for the court to refuse to give a jury “instruction when the law applies to the facts of the case”). Indeed, with the instructions given to the jury, such evidence would not even factor into their decision as to whether the Excursion was unreasonably dangerous as designed.

The refusal to give an instruction regarding the evidence presented contravenes this court’s long-held tenet that “a party is entitled to have the jury instructed on all of [its] case theories that are supported by the evidence.” [cc] While the majority recognizes that Nevada’s jurisprudence allows for the presentation of risk-utility evidence in products liability cases (albeit as part of the consumer-expectation test), it disconcertingly concludes that there was no error in the district court’s failure to instruct the jury regarding alternative design or risk-utility in this case.¹⁶⁴ With this holding, it is unclear whether the majority intends to *537 place limits on the use of risk-utility evidence in products liability cases¹⁶⁵ or intends to relax the requirement that district courts must instruct juries based on the evidence presented at trial, but what is clear is that this holding diverges from current Nevada law. The failure to give the jury instructions that are supported by both this court’s prior jurisprudence and the evidence and pleadings presented by the parties constitutes reversible error because, had the jury been instructed on the risk-utility test, the outcome of the case may have been different. *Id.*; [***].

¹⁶⁴ The majority characterizes Ford’s proposed jury instructions as asking the district court to overrule or change existing Nevada law, something a district court cannot do. But this misreads the record and the law. Nevada has never rejected feasible alternative design as an appropriate consideration in a design defect case. *See McCourt*, 103 Nev. at 102, and Nevada cases cited, *supra* [c]. And, even in its proposed risk-utility instructions, Ford included consumer expectations as a factor to be considered. Also unavailing is the majority’s suggestion that Ford somehow waived its right to have the jury instructed on alternative feasible design. It requested the instructions; it objected to the failure to give them; and it moved for a new trial based on instructional error. The law does not require more. *See Johnson v. Egtedar*, 112 Nev. 428, 434–35 (1996) (recognizing that if a court is “adequately apprised of the issue of law involved and was given an opportunity to correct the error,” then a party has adequately reserved a jury instruction issue for appellate review).

¹⁶⁵ If this is the majority’s intent, such a holding would place Nevada in the extreme minority of jurisdictions that do not allow any evidence of risk-utility in design defect cases as is discussed more in depth in the next section. See Aaron D. Twerski & James A. Henderson, Jr., *Manufacturers’ Liability for Defective Product Designs: The Triumph of Risk–Utility*, 74 Brook. L. Rev. 1061, 1104–05 (2009).

This court encountered a similar jury instruction issue in *Lewis v. Sea Ray Boats, Inc.*, 119 Nev. 100 (2003). In that case involving an allegation of an inadequate warning on a boat’s generator, a party requested an instruction that would define “adequate warning” for the jury. *Id.* at 104–05. The court refused to give the instruction and instead gave more generalized instructions.¹⁶⁶ *Id.* at 105. On appeal, this court held that the general instructions were insufficient to guide the jury both because jurors had “to search their imaginations to test the adequacy of the warnings” and because, due to the expert witness testimony given, the jurors were “entitled to more specific guidance” on the law governing the case. *Id.* at 108.

The same reasoning should be applied here: the more specific instructions provided greater guidance to the jury and the district court’s failure to give those more specific instructions warrants a reversal of the jury verdict and a remand for a new trial. [***]

Based on the foregoing, I would reverse and remand this matter for a new trial.

The majority’s approval of jury instructions that focus on consumer expectations to the exclusion of risk-utility considerations not only contravenes preexisting Nevada law, it also makes Nevada an outlier, as only a small minority of jurisdictions rely solely on consumer expectations in design defect cases. *See Twerski & Henderson, Manufacturers’ Liability for Defective Product Designs*, 74 Brook. L. Rev. at 1104–05 (stating that only Kansas, Nebraska, Oklahoma, Wisconsin, and possibly Maryland solely apply a consumer-expectation test to design defect claims); *but see* Wis. Stat. Ann. § 895.047(1)(a) (West 2015) (by statute adopted in 2011, Wisconsin follows a risk-utility approach in design defect cases). En route to this holding, the majority also mischaracterizes the risk-utility test as presented by the Restatement (Third) and how it is applied.

Like Nevada (at least until today), most jurisdictions recognize that both consumer expectations and feasible alternative design or risk-utility evidence have legitimate roles to play in design defect cases. Feasible alternative design evidence plays a predominant role in design defect, as opposed to manufacturing defect, cases because of the difference in the two types of claims: “Whereas a manufacturing defect consists of a product unit’s failure to meet the manufacturer’s design specifications, a product asserted to have a defective design meets the manufacturer’s design specifications but raises the question whether the specifications themselves create unreasonable risk.” Restatement (Third) of Torts: Products Liability § 2 cmt. d.

Analyzing the manufacturer’s design choice cannot be done in a void, leading courts to strike a balance between the consumer-expectation test and risk-utility test. California has created a test *539 wherein consumer expectations are reserved for those cases where “*everyday experience* of the product’s users permits a conclusion that the product’s design violated *minimum* safety assumptions, and is thus defective *regardless of expert opinion about the merits of the design.*” [c]; *see also* Twerski & Henderson, *Manufacturers’ Liability for Defective Product Designs*, 74 Brook. L. Rev. at 1098–1101 (listing ten other jurisdictions that use the same approach as California). Thus, the jury [in those jurisdictions] is exclusively instructed on risk-utility only when the evidence presented would not support a jury verdict based on consumer expectations. [c] Illinois’ approach is to include consumer

¹⁶⁶ The proposed instruction provided that a warning must be designed to catch the attention of the consumer, give a fair indication of the specific risks attributable to the product, and that the intensity of the warning match the danger being warned against. *Lewis*, 119 Nev. at 105. In comparison, the given instruction merely provided that whether a warning was legally sufficient depended upon the language used and its impression on the consumer. *Id.*

expectations as a factor to consider under the risk-utility test when the evidence presented at trial implicates both tests, with the alternative design criteria controlling in design defect cases. [c]

Even those jurisdictions that appear to exclusively adopt a risk-utility test for design defect cases nevertheless recognize consumer expectations as a factor for consideration. *Compare Gen. Motors Corp. v. Jernigan*, 883 So.2d 646, 662 (Ala. 2003) (holding that a safer alternative design is required in design defect cases raised under Alabama’s Extended Manufacturer’s Liability Doctrine and cited by the majority for the proposition that Alabama exclusively uses the risk-utility test), *with Horn v. Fadal Machining Ctrs., LLC*, 972 So.2d 63, 70 (Ala. 2007) (providing that a claim under the same doctrine can be won by showing the product failed to meet consumer expectations). *See also Banks v. ICI Americas, Inc.*, 264 Ga. 732 (1994) (listing factors relevant to a risk-utility analysis, which include “the user’s knowledge of the product ... as well as common knowledge and the expectation of danger”); *Wright v. Brooke Grp. Ltd.*, 652 N.W.2d 159, 170 (Iowa 2002) (“Although consumer expectations are not the sole focus in evaluating the defectiveness of a product under the [Third] Products Restatement, consumer expectations remain relevant in design defect cases.”); *Nichols v. Union Underwear Co.*, 602 S.W.2d 429, 432–33 (Ky. 1980) (holding that consumer expectations is a factor to be considered in a design defect case, along with other risk-utility factors); *Williams v. Bennett*, 921 So.2d 1269, 1275 (Miss. 2006) (quoting *Clark v. Brass Eagle, Inc.*, 866 So.2d 456, 460 (Miss. 2004), with approval and *Clark* notes that Mississippi’s products liability law is a hybrid of the consumer-expectation test and the risk-utility test); *Uniroyal Goodrich Tire Co. v. Martinez*, 977 S.W.2d 328, 335–37 (Tex. 1998) (refusing to adopt a new rule of law regarding design defect and recognizing that the risk-utility test includes consideration of the consumer’s expectations of the product). The Restatement (Third) also provides a comprehensive analysis of this issue, concluding that the risk-utility analysis should predominate in design defect cases but *540 still include consideration of consumers’ expectations. Restatement (Third) of Torts: Products Liability § 2 & cmt. f.

The varied foregoing approaches to incorporating both the consumer-expectations test and the risk-utility test into design defect cases demonstrate the difficulty presented by this issue. The fact that the task is difficult or that there may be more than one possible solution, however, does not justify the majority’s decision to exclude all references to risk-utility evidence in the instructions given to the jury.

The majority gives a series of reasons for rejecting the risk-utility approach offered by the Restatement (Third). On the surface, the concerns seem legitimate but, at their core, they rest on a fundamental misunderstanding of what the Restatement (Third) actually proposes in design defect cases.

First, the majority asserts that by requiring evidence of a feasible alternative design prior to the discovery process, the risk-utility test places a “prohibitive barrier” to a plaintiff bringing a case, especially since the defendant controls the information related to product design. [c] But the Restatement’s feasible alternative design provision relates to proof *at trial*, after discovery, and specifically “assume[s] that the plaintiff will have the opportunity to conduct reasonable discovery so as to ascertain whether an alternative design is practical.” Restatement (Third) of Torts: Products Liability § 2 cmt. f. Thus, the feasible alternative design requirement is not a mandatory prerequisite to filing a design defect claim under the Restatement (Third).

Second, the majority criticizes the Restatement (Third) as failing to recognize that proof of a feasible alternative design should not be required in every design defect case, especially those where no feasible alternative design exists. [c] But again, the Restatement (Third) does not propose the rule the majority criticizes. On the contrary, the Restatement makes specific provision for design defect claims that do not require feasible alternative design evidence. For example, if the product is manifestly unreasonable, or it has little social use and a high degree of danger, a court may declare it to be defective in design without evidence of a feasible alternative design. See Restatement (Third) of Torts: Products Liability § 2 cmt. e (using the example of a child’s pellet gun that uses pellets hard enough to cause injury).

Going beyond the comments to section 2, section 3 of the Restatement (Third) provides for imposition of strict liability without regard to alternative design in cases involving inexplicable product malfunction. Restatement (Third) of Torts: Products Liability § 3 *541 [***] This section comports with Nevada product liability law. Indeed, the Reporter’s Note to section 3, cmt. b, of the Restatement (Third) quotes with approval this court’s holding in *Stackiewicz v. Nissan Motor Corp. in U.S.A.*, 100 Nev. 443, 448 (1984), “that proof of an unexpected, dangerous malfunction may suffice to establish a prima facie case for the plaintiff of the existence of a product defect.” [***]

In sum, the majority’s suggestion that the Restatement (Third) requires proof of alternative design in all design defect cases is simply incorrect. There are numerous instances wherein a plaintiff could succeed on a design defect claim without providing evidence of a feasible alternative design.

The error in the instructions requires reversal and remand for a new trial. By affirming the instructions the jury was given, the majority has moved Nevada from the mainstream—where courts and commentators alike are striving to strike the proper balance between risk-utility and consumer-expectations analyses in design defect cases—to a minority of three or four jurisdictions that rely solely on consumer expectations. While I do not necessarily advocate for the Restatement (Third) over the approaches variously taken by California or Illinois, Nevada should at a minimum adhere to its prior case law recognizing that feasible alternative design has a legitimate and important role to play in design defect cases. As the complete elimination of feasible alternative design from the design-defect calculus is unsound, I respectfully dissent.

Note 1. The Role of the Jury. *Trejo* reflects the extensive process that can take place when the parties seek to finalize jury instructions before a trial. They may fight about the language of a single instruction or dispute the legal accuracy of one or more instructions as they are “settling instructions,” as the court puts it. In general, jury decision making is like a “black box” in that we do not know what led to jurors’ decisions or how they arrived at particular numbers, other than by comparing final verdicts with what parties requested or argued. However, in certain cases, the parties may propose use of a “special verdict” form in which the jury is asked to answer a number of questions or to provide answers regarding elements, claims or amounts of damages. In *Trejo*, the jury was asked to answer (1) whether the 2000 Ford Excursion’s roof was defective in design, and, if so, (2) whether the 2000 Ford Excursion’s roof design defect was a proximate cause of Rafael Trejo’s death.

Judges are very reluctant to set aside a jury verdict once it has been issued. To do so usually requires that it be “against the weight of the evidence.” With a general verdict—one in which a jury is asked only whether a party is liable or not—the parties may struggle on appeal since there is little to which to attach criticism of or praise for the jury’s verdict. Unlike judicial opinions, which contain precedents and other authorities as well as rationales and reasoning to critique, jury verdicts do not reflect the

juries' analysis in a manner that permits subsequent parties to review jury decision making. The black-box nature of jury review shields their work and consequently places additional pressure on the wording and nature of the jury instructions since those are easier to attack as erroneous on appeal. Appellate review of the accuracy and propriety of jury instructions is a question of law subject to the de novo standard of review. Judges do have considerably more latitude to find errors exist with respect to jury *instructions* versus their much more limited ability to disturb jury *verdicts*. However, even if judges find errors in the jury instructions, "harmless errors" will not provide grounds for reversal. If the instructions were erroneous but the court believes the error did not taint the final verdict, the errors will be considered "harmless" and the court will not disturb the jury verdict merely to correct them. Consider why you might wish to use a general verdict versus a special verdict if you were involved in litigation. What factors might shape your thinking?

Fewer and fewer cases make it all the way to a jury in civil litigation in our era; the institution has been referred to as "the vanishing jury" and "the disappearing jury," for instance. This change is partly a function of changes to motion practice and partly reflective of the rise of administrative mechanisms for resolving claims in a fashion that permits parties to end disputes more inexpensively and quickly. In addition, insurance companies played an increasingly larger role in tort law over the course of the 20th century, which meant both that efficiency drove decision making and individual claims could be more easily handled at scale. Yet many of the cases you read feature a fight over the jury, or jury instructions. Students learning the law read many cases in which the jury plays a prominent role. Is the fixation on the jury a relic? Or is it purely symbolic, given the dropping rates at which trials are statistically likely to feature them? Lawyers at the start of significant litigation often start by consulting the jury instructions relevant to the issue and jurisdiction of the dispute as a means of assessing and framing the case. One theory of the jury's role is that it scares both parties into settling more readily since juries are thought to be more unpredictable. If the parties do proceed to a full jury trial, it will prove to be critical that the case's issues have been framed in terms of jury instructions from the very start. In some sense, then, anticipating the jury's very possibility continues to exert an impact on the shape and operation of the law, regardless of the lower number of jury trials. Another theory of the jury function is that it humanizes and democratizes the law, however, and that its role remains critical in our legal regime whatever the case count. If tort law continues to require determinations of what is "reasonable" under the circumstances, doesn't it still need the jury? What alternatives would make the most sense to you? What costs and benefits arise with any of those you may be considering?

Note 2. State of the Art Defense. The court mentions that Ford requested a "state of the art defense" (and was refused). This is an affirmative defense recognized judicially or legislatively in a number of jurisdictions which permits defendant manufacturers to assert that they behaved according to the best available knowledge at the time. In other words, their theory of non-liability is that they could not have known about the hazard when they made or sold their product because the state of the art at that time had not yet discovered particular risks. As you can see, there may be overlap between the evidence required to show the feasibility of a reasonable alternative design and the evidence required to prove up the state of the art defense. Who should be taxed with offering this kind of evidence, in your view, the plaintiff or the defendant?

Note 3. In the unabridged version of *Ford v. Trejo*, the court cites to a Wisconsin case that held that the consumer expectations test "does not inevitably require any degree of scientific understanding about the product itself. Rather, it requires understanding of how safely the ordinary consumer would

expect the product to serve its intended purpose.” (p. *528 citing *Green v. Smith & Nephew AHP, Inc.*, 245 Wis.2d 772 (2001)). Ford argued that it was “extremely unlikely that the Trejos bought their Excursion with any specific expectation regarding the strength-to-weight ratio of the vehicle roof.” Ultimately, the court disregarded Ford’s argument and ruled that Trejo had presented sufficient evidence for the jury to conclude that the level of protection actually provided by the roof in a rollover accident was less than would be expected by a reasonable consumer. The court stated that, in this case, the distinction between the risk-utility and consumer expectation tests was immaterial. But was Ford’s argument the right one, in any event? Do you think that the consumer expectations test asks jurors to determine whether a reasonable consumer would investigate and form expectations about the strength-to-weight ratios of vehicles? What would your questions look like if you were considering purchase of an expensive and complex consumer product such as a vehicle? What do you assume about how you make such decisions versus how you imagine others might? Can you imagine alternative framings for the consumer expectations test in this case?

Expand On Your Understanding – Socratic Script: Ford Motor Company v. Trejo

Question 1. What is the holding of this case?

An interactive H5P element has been excluded from this version of the text. You can view it online here: <https://saidtorts2d.lawbooks.cali.org/?p=88#h5p-108>

Question 2. What’s the difference between the majority and dissenting opinions’ views of the proper use of alternative design evidence?

An interactive H5P element has been excluded from this version of the text. You can view it online here: <https://saidtorts2d.lawbooks.cali.org/?p=88#h5p-109>

Question 3. What is California’s test, according to *Ford v. Trejo*? Try to put it in your own words for your answer rather than quoting directly from the case. Articulating the test for yourself will then allow you to use the answer, which quotes directly from the case, to test your active (rather than merely passive) understanding.

An interactive H5P element has been excluded from this version of the text. You can view it online here: <https://saidtorts2d.lawbooks.cali.org/?p=88#h5p-110>

Question 4. What do you think are the effects of the California test?

An interactive H5P element has been excluded from this version of the text. You can view it online here: <https://saidtorts2d.lawbooks.cali.org/?p=88#h5p-111>

Question 5. The court refers to the distinction between focusing on **the conduct of the manufacturer in designing and developing the product**, rather than **the product itself**, and states that focusing on the manufacturer’s conduct is in “direct conflict with the reasoning of this court in *Shoshone* and its progeny.” What is the significance of this distinction between conduct and product? What is the conflict to which the court alludes concerning *Shoshone* (which was the case about the decomposing mouse in the bottle of Squirt mentioned in the majority opinion)?

An interactive H5P element has been excluded from this version of the text. You can view it online here: <https://saidtorts2d.lawbooks.cali.org/?p=88#h5p-112>

Question 6. In its discussion of *Shoshone*, the court reaffirms its commitment to the application of strict liability, even when there is no evidence of fault and the injured party is not in a contract with the defendant, so long as “a manufacturer has placed a dangerous or defective product into the stream of commerce.” Applying the logic of *Thomas v. Winchester*, how would you formulate a rationale for the court’s statement?

An interactive H5P element has been excluded from this version of the text. You can view it online here: <https://saidtorts2d.lawbooks.cali.org/?p=88#h5p-113>

Question 7. How significant do you think it is that the vehicle did not meet Ford’s own internal guidelines for roof strength? Can you think of reasons why it should or should not matter to the ultimate determination?

An interactive H5P element has been excluded from this version of the text. You can view it online here: <https://saidtorts2d.lawbooks.cali.org/?p=88#h5p-114>

Defective Instructions or Warnings

Shinedling v. Sunbeam Products, Inc., U.S. Dist. Court, C.D. Cal. (2014) (2014 WL 12589646)(not reported)

This is a products liability action arising from the death of Amy Celeste Shinedling in a house fire on January 5, 2011. Ms. Shinedling’s surviving husband, Kenneth Shinedling, brought this action on behalf of himself and as Guardian ad Litem for their surviving children (collectively, “Plaintiffs”) on December 15, 2011. Plaintiffs’ remaining claims assert strict products liability and negligence against Defendant Sunbeam Products, Inc., (“Sunbeam”), the manufacturer of the portable space heater that allegedly caused the house fire. [c] Plaintiffs allege that the heater caused the fire because it was

defectively designed, contained a manufacturing defect, and failed to include adequate warnings. Before the Court is Sunbeam's motion for partial summary judgment as to Plaintiffs' manufacturing defect and failure-to-warn bases for their strict products liability and negligence claims. [fn]

The product at issue is the Holmes Quartz Heater, Model HQH307, manufactured in 2006 (the "Heater"). [fn] The Heater is a type of portable electric heater known as a radiant quartz heater. As opposed to ceramic or convection-type heaters, which blow hot air to heat an entire space, radiant heaters radiate infrared heat that directly heats solid objects in its path. The Heater is sold with an instructional leaflet with a number of warnings, including:

"When using electrical appliances, basic safety precautions should always be followed to reduce the risk of fire, electric shock, and injury to persons, including the following:
... 3. This heater is hot when in use. To avoid burns, do not let bare skin touch hot surfaces. If provided, use handles when moving this heater. Keep combustible materials, such as furniture, pillows, bedding, paper, clothes, and curtains at least 3 feet (0.9 m) from the front of the heater and keep them away from the sides and rear."

A similar warning regarding keeping materials 3 feet away was displayed on the Heater's power cord and on the body of the Heater itself. The instructional leaflet provided with the Heater also describes the Heater's "Auto Safety Shut-Off" feature. The description states:

"The heater is equipped with a patented, technologically-advanced safety system that requires the user to reset the heater if there is a potential overheat situation. When a potential overheat temperature is reached, the system will automatically shut the heater off."

***2** The night of January 4, 2011, Mr. and Mrs. Shinedling went to sleep with the Heater and another space heater in operation in the master bedroom of their home. At the time Mr. Shinedling went to sleep there were no clothes or combustible materials within 3 feet of the Heater. In the early morning hours, Mr. Shinedling awoke to the sound of a smoke alarm. He got up and saw clothes in front of the Heater which had caught fire, along with the Heater itself. His wife told him to get the children out of the house, which he did, and then he called 911. Mr. Shinedling attempted to reenter the home to locate his wife but the fire had grown too intense. Mrs. Shinedling died in the fire.

[***] ***3** Under California law, "[a] manufacturer is strictly liable in tort when an article he places on the market, knowing that it is to be used without inspection for defects, proves to have a defect that causes injury to a human being." [c]. [***] Sunbeam's motion for partial summary judgment is limited to Plaintiffs' manufacturing defect and warning defect theories only. The Court will address these theories in turn.

a. Manufacturing Defect

[***] ("[A] product has a manufacturing defect if the product as manufactured does not conform to the manufacturer's design."). "[T]o establish liability, it is not enough that the action happened, nor may liability inferences favorable to plaintiff be drawn from that fact. The plaintiff must prove by competent evidence that the product was [defective in manufacture]." [c]

Plaintiffs have not introduced sufficient evidence to create a genuine dispute that the Heater in question contained a manufacturing defect. Plaintiffs concede that they have no direct evidence of any

manufacturing defect. Instead, Plaintiffs rely on *Vandermark v. Ford Motor Co.*, 61 Cal. 2d 256, 260 (1964), and *Elmore v. American Motors Corp.*, 70 Cal. 2d 578 (1969), to argue that circumstantial evidence may suffice to prove the existence of a manufacturing defect where the product was destroyed in the incident at issue. The circumstantial evidence that, according to Plaintiffs, creates a genuine dispute that the Heater had a manufacturing defect includes: there is no evidence that the Heater was modified after it left Sunbeam's possession; "there are historical reports of the bottom of this type of heater burning and melting and starting fires, as verified by Sunbeam"; Mr. Shinedling testified that he saw the Heater itself on fire in addition to the clothes surrounding the Heater; a failure of an internal connection could potentially start a fire; such a failure could have produced a fire burning at the same temperature as the fire at issue; the carpet underneath the Heater was burned; and the point of origin of the fire was determined to be at or near the Heater's location.

Plaintiffs' circumstantial evidence is too speculative to proceed before a jury on the issue of whether the Heater contained a manufacturing defect. The cases Plaintiffs rely on for the proposition that the existence of a defect can be established by circumstantial evidence all involved at least *some* evidence from which an inference of a defect could be drawn. *Elmore*, for instance, was a products liability action arising from a car accident that occurred because a part detached from the bottom of the plaintiff's car and dragged on the cement, causing her to lose control and crash. [c] The plaintiff's evidence included expert testimony that the vehicle's drive shaft detached prior to the accident, the cause of the drive shaft detaching was loose fastenings or metal failure, and a drive shaft would not detach because of normal wear and tear, the forces of the subsequent accident, or "anything the driver did." [c] The expert testified that it was his opinion that the drive shaft connection was defective. In contrast, Plaintiffs' own expert on the issue of manufacturing defect cannot conclude that the Heater contained a manufacturing defect. Plaintiffs' expert merely states that he *could not rule out the possibility* of a manufacturing defect. ("[T]he possibility that extreme heat was generated at that connection leading to ignition of the heater from the inside could be neither confirmed nor refuted.") Further, Plaintiffs concede that their "origin and cause" expert, as well as Sunbeam's experts, all agree that "it is more likely than not that the cause of the fire was the ignition of the clothing by the heater." Sunbeam is entitled to partial summary judgment as to the manufacturing defect basis for Plaintiffs' strict liability claim.¹⁶⁷

b. Failure to Warn

*4 To prevail on a failure-to-warn theory, the plaintiff must show that the defendant "did not adequately warn of a particular risk that was known or knowable in light of the generally recognized and prevailing best scientific and medical knowledge available at the time of manufacture and

¹⁶⁷ The relevant evidence Plaintiffs submit in support of their assertion that "there are historical reports of the bottom of this type of heater burning and melting and starting fires" consists of two customer complaints involving the same or similar heaters in the time period from 2004 to 2014 which reported failure of internal wiring that burned through the bottom of the heater. Internal wire failures that result in fires, according to Plaintiffs' expert, are "typically the result of a poor electrical contact due to improper assembly of the connection." Notably, Plaintiffs' expert found that the customer complaints contained "insufficient information ... to perform an independent analysis, so the comments within the summary are not intended to reflect conclusions," and based on the information available to him, "it is impractical to make an independent determination of cause with specificity for any of the reported incidents." Even taking the evidence in the light most favorable to Plaintiffs, it would be too speculative to say that these isolated reports of fire-causing internal wire failure in other heaters over a 10-year period create a triable issue that the Shinedlings' heater contained an internal wiring defect that existed because of a manufacturing error, and that failure of this defective internal wiring substantially caused the fire at issue.

distribution.” [c] (“[A] product, although faultlessly made, may nevertheless be deemed ‘defective’ under the rule and subject the supplier thereof to strict liability if it is unreasonably dangerous to place the product in the hands of a user without a suitable warning and the product is supplied and no warning is given.”) California courts have identified several factors pertinent to determining the adequacy of warnings, including the risk of harm and magnitude of potential harm the product presents, the normal expectations of the consumer as to how the product will perform, how complicated it is to use the product, and the feasibility and beneficial effect of a warning. [c] The adequacy of the warnings provided with a product is generally a question of fact for the jury. [c]

Genuine disputed issues regarding the adequacy of the Heater’s warnings preclude partial summary judgment on Plaintiffs’ failure-to-warn theory. These issues include, among others, whether the warnings were inadequate because they failed to advise the user that the Heater should never be left on while sleeping. A bulletin published by the U.S. Consumer Products Safety Commission regarding portable electric heater fires between 2008 and 2010 included safety warnings which, in addition to warning consumers to keep materials at least 3 feet away from heaters, also warned consumers “[n]ever leave the heater operating while unattended, or while you are sleeping.”

A triable issue also exists as to Plaintiffs’ contention that additional warnings should have been given regarding the Heater’s Auto Safety Shut-Off feature. Sunbeam argues that this feature was intended to address potential overheat temperatures occurring inside the Heater only. A reasonable jury, however, could find that, in light of the representation in the Heater leaflet that “[w]hen a potential overheat temperature is reached, the system will automatically shut the heater off” and the risk of danger and magnitude of harm a space heater could cause, the lack of additional warnings made the Heater defective. Nor does the fact that Mr. Shinedling testified at deposition that he read and understand the warning to keep materials 3 feet away from the Heater preclude a jury determination as to whether additional warnings were necessary under these circumstances.

c. Negligence

Sunbeam also moves for partial summary judgment on Plaintiffs’ negligence claim to the extent it relies on manufacturing defect or warning defect theories. Negligent products liability, like strict liability, requires proof that a defect in the product caused the plaintiff’s injury. [c] A negligence claim requires the additional element that the defect in the product was due to the defendant’s negligence. Sunbeam is entitled to partial summary judgment on Plaintiffs’ negligence claim to the extent that it is premised on a manufacturing defect in the Heater, for the same reasons discussed in connection with strict liability above. Sunbeam has not shown that summary judgment is warranted as to Plaintiffs’ negligent warning defect theory.

For the foregoing reasons, the Court GRANTS IN PART Sunbeam’s motion for partial summary judgment.

Note 1. Why did the court find that the plaintiffs had failed to make out a manufacturing defect? What might have made a difference, in your view?

Note 2. What was the significance of the plaintiffs’ assertion that the heater had not been modified after it left Sunbeam’s possession?

Note 3. A manufacturer may be liable for a failure to warn if they “did not adequately warn of a particular risk that was *known or knowable* in light of the generally recognized and prevailing best scientific and medical knowledge available at the time of manufacture and distribution” (emphasis added). What does it mean for a risk to be “known or knowable”? What standard or standards of conduct does the phrase reflect, and why do you think the range exists?

Note 4. What factors, in combination, caused the court to allow the case to proceed on a theory of failure to warn? What standard (objective or subjective) did the court’s reasoning reflect? Why did it not seem to matter that Mr. Shinedling testified that he had understood the warning to keep materials three feet away from the heater? You may recall *Garrison v. Deschutes* (Sup. Ct. Or. 2002) from Module 3, Causation, in which the court found there was no liability for Deschutes County’s failure to warn of risk of falling due to the lack of any barrier guarding the drop-off at the Fryrear transfer station because Garrison and his wife admitted knowing of the danger). Is this case distinguishable, in your opinion? If so, what makes it so?

Note 5. The Malleability of The “Unreasonably Dangerous” Standard. California rejected the Restatement § 402A’s approach to “unreasonably dangerous” products. Given that the majority of jurisdictions have chosen to retain it in some fashion, how are “unreasonably dangerous” products defined? Many accidents occur each year in connection with ladders, lawn mowers, and swimming pools. Significant injuries and death continue to result from gun ownership and tobacco use (which also causes substantial disease in users and those in their households). But all—from ladders through tobacco—are indisputably prevalent features of American life. Should all products that are classified as “inherently dangerous” in some way be treated the same way under tort law or do they merit particularized treatment? For instance, what warnings should manufacturers (and sellers) be required to provide for products like cigarettes? Alcohol? Vapes? Cannabis-infused products? How about products that include butter (as an ingredient traced to heart disease)? Sugary sodas and fatty foods? Should products associated with significant dangerous allergies be required to carry warnings?

There are doctrinal and pragmatic answers to these questions. Doctrinally, once significant risks become foreseeable (“known or knowable,” to be more precise), a failure to warn can lead to liability but usually requires that the risk be general enough to be of common application. If a tiny percentage of the population has a rare allergy to some component of a product, the risk may not be enough to create a duty to warn. The sufferer of this rare allergy is almost certainly on notice that they must take extra precautions. But the greater the prevalence of the risk, the greater the likelihood that the duty to warn exists. Pragmatically, the answer is partly a function of political power; products with powerful industry organizations can and do lobby for favorable legislation that may immunize or limit their likely liability, regardless of the danger of their products.

Check Your Understanding (5-3)

Question 1. A self-driving car crashes into a pedestrian and the pedestrian seeks to recover for their injuries. Which of the following, if true, would make recovery easiest?

An interactive H5P element has been excluded from this version of the text. You can view it online here: <https://saidtorts2d.lawbooks.cali.org/?p=88#h5p-115>

Expand On Your Understanding – Stinky Raw Cheese Hypothetical

Practice Applying Rules from Prior Cases

A local farmer's market that runs every Saturday morning features a business, Fox Farms, which sells stinky fresh cheese made on their farm. Some of their cheeses are unpasteurized, which their customers love. It is difficult to find stinky unpasteurized cheeses in stores since they carry the risk of harboring e. coli, salmonella, listeria, and other pathogens that can cause vomiting, diarrhea and other serious gastrointestinal complications. Pregnant women, for instance, are advised to avoid unpasteurized food entirely. Fox Farms' clients seek this farm's cheeses out specially and the business runs out well before the end of the market every week. The farm maintains a chalkboard that lists its selections and most weeks, one of the employees writes UNPASTEURIZED at the top of the board and marks which cheeses are unpasteurized. In smaller print, there is a warning about the health hazards of eating such cheeses. One line specifically states: "We recommend that PREGNANT WOMAN avoid these cheeses!"

On a recent Saturday, a new employee forgot to write UNPASTEURIZED at the top of the board and thus failed to list which cheeses were unpasteurized. In at least a few cases, he remembers verbally telling customers that the cheeses they were selecting were unpasteurized but he concedes that he cannot recall, in all cases, whether he did so. As usual that day, the unpasteurized cheeses sold out much faster than the other offerings, suggesting that at least some consumers were, as usual, seeking out these particular cheeses with knowledge of their benefits and risks.

Unfortunately, Fox discovered its first-ever e. coli outbreak and diligently began trying to trace its steps to minimize the possible harm. However, the damage was done and several customers were made violently ill, including one pregnant woman, who died as a result. The employee who had forgotten to warn felt terrible upon learning that some people were unaware of the risk. He was otherwise a very careful and responsible individual.

For the following hypotheticals, consider whether the plaintiffs are likely to recover. Each is designed to trigger the application of a rule from a case you have read. (If the facts look completely unfamiliar, this exercise may either serve as a helpful review or may indicate a case that your professor has not assigned; don't worry about it too much either way. These exercises are meant to teach and reinforce as much as they "review what you already know.") As a side note, in the real world, layers of regulation may apply to safeguard food sources (and certain immunities may also exist to shield some actors in the supply and vending chain). For our purposes, focus only on the principles of law you have learned in connection with your study of tort law. Turn each card to reveal the answer.

An interactive H5P element has been excluded from this version of the text. You can view it online here: <https://saidtorts2d.lawbooks.cali.org/?p=88#h5p-116>

Chapter 31. Defenses to Products Liability

Various defenses limit the scope of potential liability for injuries caused in connection with defective products. The most common doctrinal defenses are probably **misuse** and **modification**. In addition to having to prove some form of defect (or alternatively, breach of either warranty or due care), plaintiffs must often be able to show that they **did not misuse a product**. If a plaintiff suffers injuries when trying to use a car as a boat, for instance, the fault lies with the plaintiff, not the defendant for failing to anticipate such a use. However, some uses are so common that they have become foreseeable even if they are not the intended use for the product. For instance, a chair is meant to be sat on, not climbed. Yet it has long been treated as foreseeable that a chair will be used as a stepstool in lieu of a ladder, for reaching higher-up items. It would not be a misuse for someone to use a chair in such a way in their home. There may be a duty to anticipate foreseeable misuses, in other words. Plaintiffs may also need to be able to show **the product has not been modified** since leaving the defendant's control. This may require proof that the plaintiff has not altered the product or that there was no intervening third-party force that could constitute a **superseding cause** and sever the chain of causation.

In some instances, courts will use duty to limit defendants' liability, as when the risks associated with a product are open and obvious. Consider the case of aboveground pools, which are swimming pools that rise above ground level rather than being dug into a corresponding hole in the ground. In the 1980s, the pool construction industry found itself targeted in multiple lawsuits over spinal injuries suffered by people who dived headfirst into these structures. Unlike most other bodies of water, including in-ground swimming pools, the depth—or more accurately, the shallowness—of an aboveground pool is plainly discernible to tort law's "reasonable person." The general rule is that there is **no duty to warn of open and obvious dangers**. So as long as the defendant can prove that the danger was indeed open and obvious, duty analysis may shield them their liability.

Is what is "open and obvious" the same for all people? If warnings express a risk well enough that many or *most* people understand it and can choose whether to avoid the risk, is that good enough or should a warning make risks patently clear to all foreseeable users?

Recent Controversy. In 2021, a young woman, Tessica Brown, apparently ran out of her regular hair product, "Got2Be Glued" and used Gorilla Glue adhesive spray to set her hair instead. When she was unable to remove it for a month, she posted a video on TikTok seeking help. The video immediately went viral and has now been viewed over 50 million times as of Feb. 24, 2022, see: <https://www.klfy.com/louisiana/one-year-later-gorilla-glue-girl-tessica-browns-life-is-transformed-for-the-better/>. Brown did receive advice and some offers of help though she also was subject to some criticism for using the glue in this way. A report that she was contemplating litigation against the manufacturer of Gorilla Glue turned out to false, but at least two personal injury attorneys believed Brown had a claim that could survive the pleading stage had she decided to sue. <https://www.insider.com/tessica-brown-gorilla-glue-hair-lawyers-weigh-in-2021-2>

Presumably, Gorilla Glue's purported liability would be based on a failure to warn since the company "says do not use on eyes, skin or clothing ... with no mention of hair."

What do you think? Is it “open and obvious” that glue should not be used on hair? Are you familiar with Got2Be Glued and its uses on hair? Would it matter to your answer if you knew or learned that a subset of the population—mainly women of color—used a product that included glue-like characteristics on their hair? Consider the following excerpt of an article about using that product:

Got2b glued is a “water-resistant” hair styling/spiking gel from the brand Schwarzkopf. Schwarzkopf is a professional brand of hair care products. The Got2b glued gel is the newest trend of securing wig and frontal units. ... Got2b glued comes in a white (regular) or clear (ultra hold) form. Both products boast water-resistant claims of a screaming hold. Still not following me? That’s okay. What these users are doing, including myself, is applying a thin layer of the gel to whatever area they want their lace wig to be applied to. Once the gel has dried to a tacky consistency, the lace wig is then applied for a strong glue-like hold! Awesome, right? Well, maybe not so awesome for some. I have come across reports of lack of hold, difficulty removing, and hair loss as a result of this product. <https://thecrissymack.com/2017/04/13/7-things-they-didnt-tell-you-about-got2b-glued-for-your-lace-wig/>

Does Brown’s use of Gorilla Glue seem different in light of the existence of this existing hair adhesion product and its widespread use in hair care? Does Gorilla Glue have a responsibility to anticipate foreseeable misuses such as these, and whose perspective determines what is deemed foreseeable? In the alternative, should a risk like extra-strong glue’s remaining adhered to hair be considered “open and obvious”? How might tort law’s purposes guide your considerations?

Happily, a year and a half after the incident, Tessica Brown appears to be all healed and the owner of a successful haircare business: <https://www.klfy.com/louisiana/one-year-later-gorilla-glue-girl-tessica-browns-life-is-transformed-for-the-better/> “She now also owns a successful haircare line.”

Certain categories of actors have been immunized from liability in connection with injuries caused by products liability. Pharmaceutical and medical device manufacturers are protected by the **learned intermediary doctrine**, which holds that the “learned intermediary” who interacts with patients or consumers of the product is the one responsible for warning them of the products’ risks. The manufacturers owe a duty to warn the learned intermediary appropriately but from that point forward, their liability is limited or extinguished. A general exception for oral contraceptives has been recognized in light of the fact that consumers may not consult as meaningfully with a doctor in that medical context as in almost every other. The learned intermediary doctrine has been adopted in most U.S. jurisdictions, though it is subject to multiple critiques. Pharmaceutical companies often market directly to consumers, which would seem to eliminate the role of a learned intermediary. Physicians may enter consulting arrangements or otherwise accept compensation from pharmaceutical companies, which has also subjected the doctrine to criticisms of potential conflicts of interest. Notwithstanding these critiques, efforts among representatives of the plaintiffs’ bar to create “direct to consumer” or “physician compensation” exceptions have failed to gain much traction. *See e.g. DiBartolo v. Abbott Labs.*, 2012 WL 6681704 (S.D.N.Y. Dec.21, 2012); *Calisi v. Abbott Labs.*, 2013 WL 5462274 (D. Mass. Feb. 25, 2013).

Victims of injury are typically immunized from suit by first responders, fire fighters and professional rescuers (see Module 3, discussion of the “Firefighter’s rule” in connection with *Clinkscales v. Nelson Securities*, , 697 N.W.2d 836 (Iowa, 2005). However, this limitation does *not* apply to claims by professional rescuers against manufacturers or sellers of equipment or uniforms, so this is an area in which an ordinarily available defense becomes unavailable in the context of products liability.

Finally, as with other torts claims, product liability actions may be subject to **statutes of limitation and repose** (see Module 4).

The next case provides an opportunity to synthesize the various theories of product liability in a case concerning a toxin that caused respiratory disease (“popcorn lung”) due to its widespread use in microwave popcorn.

Daughetee v. Chr. Hansen Inc., U.S. District Court Iowa, Western Division (2013) (960 F. Supp.2d 849)

This case brings to mind the idiom, “Too much of a good thing can be bad for you.” In this diversity action under Iowa products liability law, plaintiffs allege that Deborah Daughetee developed “popcorn lung” by consuming multiple bags of microwave popcorn daily for several years. Presently, I am asked to determine whether the plaintiffs are entitled to present to a jury both their failure to warn and design defects. *853 [***]

Plaintiffs Deborah Daughetee and Steven Daughetee are married and residing in Albuquerque, New Mexico. [***] Symrise, Firmenich, and Hansen (collectively “defendants”) all produced butter flavorings containing diacetyl. [***] Defendants sold their butter flavorings to microwave popcorn manufacturers, including ConAgra, General Mills, and American Popcorn. General Mills and ConAgra have been aware, since the 1990s’s, that defendants’ butter flavorings contained diacetyl. ConAgra is the largest manufacturer of microwave popcorn in the United States. It operates five microwave popcorn factories and has been in the microwave popcorn business since the 1980’s. Diacetyl is a basic food chemical present in all cheeses and butters. It is an ingredient used to manufacture butter flavorings. Diacetyl is one of a number of potentially volatile organic compounds present in butter flavorings. Butter flavorings are intended to provide “buttery” taste and smell. Upon opening a microwave popcorn bag with butter flavoring, diacetyl vapors are released.

Between 1989 and 2004, Deborah regularly ate microwave popcorn. From 1989 to 2004, she prepared and consumed approximately one or two bags of microwave popcorn each day. Deborah prepared a “Product Identification” Sheet (“Product ID Sheet”) in which she identified the brands of microwave popcorn she has eaten since 1989 [including] various brands manufactured by General Mills, ConAgra, and American Popcorn. [***]

After removing a bag of butter flavored microwave popcorn from the microwave, Deborah would open the bag and draw the buttery smell into her nose and lungs. She “liked the smell of opening a bag near my face,” and liked the taste of butter flavored, microwave popcorn. Deborah first ate microwave popcorn in 1989 while working as a writer for the television show “Tour of Duty.” She prepared and

ate two bags of microwave popcorn while she worked on Tour of Duty. Typically, she would eat one bag at the office and then take another bag home with her.

[The court reviews the facts in granular detail: plaintiff was able to link certain kinds of popcorn she ate while working on certain shows, during certain time frames and purchased from certain stores (for example, Costco, where particular brands could be identified).

Deborah stopped eating popcorn in 2004 because she grew tired of it.

[The court conducts an extensive survey of the industry's actions and knowledge, including its industry-wide self-regulation mechanisms and safety protocols, the practices and state of knowledge of the various defendants with respect to the risks associated with diacetyl, and the actions of various entities that discovered that plant workers were developing lung issues and did not take responsible actions to curb the risk or inform relevant parties and partners.] [***]

[D]efendants make three arguments in support of their claim that they had no duty to warn Deborah about the harms allegedly associated with exposure to their butter flavorings. First, defendants contend that they did not owe Deborah a duty to warn because, during the time that Deborah ate microwave popcorn containing their flavorings, it was not reasonably foreseeable that their flavorings posed a risk to consumers. Second, defendants assert that, because General Mills and ConAgra were sophisticated users of flavoring products, General Mills and ConAgra were in a better position to warn consumers about their products. Finally, defendants argue that they were bulk suppliers of flavorings ingredients and were not in a position to warn consumers of General Mills and ConAgra's microwave popcorn about the dangers associated with the finished popcorn products. [***]

Under Iowa law, “[a] claim alleging a manufacturer failed to warn of the dangers involved in using a product is properly based on a theory of negligence, not strict liability.” [***] *865 Defendants, as manufacturers, are held to have the knowledge of an expert and therefore should have known of the hazards inherent in their products. “The relevant inquiry therefore is whether the reasonable manufacturer knew or should have known of the danger, in light of the generally recognized and prevailing best scientific knowledge yet failed to provide adequate warning to users or consumers.” [c] Thus, reasonable foreseeability of danger to users of a product triggers the duty to warn. A manufacturer has no duty to warn when it did not or should not have known of the danger. [c]

Defendants argue that there was no scientific or medical knowledge at the time Deborah was consuming microwave popcorn with butter flavorings which would have given them a reasonable basis to believe their product could cause injuries to consumers. The Daughetees counter that defendants had knowledge of the hazards associated with their butter flavorings, at least at some level, or that knowledge was ascertainable prior to and during Deborah's exposure. [***]

[Editor's summary: The court then details information available through the flavor industry's trade organization, FEMA, including a warning in 1985 that diacetyl was “harmful” and high concentrations were “capable of producing systemic toxicity.” From 1991-1997, the defendants were placed on varying degrees of notice. In 1991, a consultant was hired who informed Firmenich of the dangers of potent inhalation hazards of numerous chemicals, including diacetyl, and advised the company to specially label the chemical, provide additional warnings, and take additional precautions in its use and storage. In 1992, Givaudan discovered one of its employees

had been diagnosed with bronchiolitis obliterans and that one of the employees may have died as a result. In 1996, Givaudan informed FEMA of the bronchiolitis obliterans diagnosis. In 1997, FEMA held a special conference to discuss respiratory safety and discussed the suspected links between diacetyl exposure and bronchiolitis obliterans. In 2001, the Wall Street Journal published an article about the prevalence of lung disease among employees at an artificial butter flavoring manufacturing plant. Some changes in ventilation may have been made to minimize workers' exposure to diacetyl and other respiratory hazards. On August 2, 2002, [the National Institute for Occupational Safety and Health ("NIOSH")] conducted testing of the plant in question and issued an update stating that they believed that "butter flavoring in the air caused lung disease in workers at this plant."

The NIOSH update made the following observation concerning quality control exposures: "Many quality control workers had abnormal breathing tests and have continued risk even after the ventilation changes in the plant. Based on our survey results, we believe that they may receive many peak exposures to flavoring vapors when microwaving the popcorn bags, opening them, and measuring the amount of hot popcorn. When the popcorn/flavorings temperature increased, the vapor increased, although the high exposures only lasted for seconds or a few minutes. We are concerned about these short peak exposures in the quality control room and have provided recommendations for control." By 2003, NIOSH had broadened the scope of its investigations to include several of ConAgra's microwave popcorn plants. A medical survey of ConAgra's workers identified evidence of the same type of lung disease. By the end of 2003, a number of ConAgra workers had filed lawsuits alleging that they suffered lung disease as a result of exposure to butter flavorings.]

The plain language of § 2(c) focuses on the concept of "reasonableness" for judging the adequacy of warnings, a malleable concept that is intertwined with the facts and circumstances of each case. "Whether the warning actually given was reasonable in the circumstances is to be decided by the trier of fact." RESTATEMENT (THIRD) OF TORTS: PRODUCTS LIABILITY § 2 cmt. i. [***] No easy guideline exists for courts to adopt in assessing the adequacy of product warnings and instructions. In making their assessments, courts must focus on various factors, such as content and comprehensibility, intensity of expression, and the characteristics of expected user groups. *Id.*

I find that the information and circumstances detailed above, considered in the light most favorable to the Daughetees, generates genuine issues of material fact as to whether defendants knew or had reason to know that their butter flavorings posed a potential risk, at some level, to consumers, thus triggering the necessity for a warning. Therefore, this portion of defendants' motion for summary judgment on the failure-to-warn claims is denied.

b. Intermediary user defense

Defendants also move for summary judgment on the Daughetees' failure to warn claims because General Mills and ConAgra were "sophisticated" intermediary users of their butter flavoring products and, thus, defendants were entitled to rely on General Mills and ConAgra to provide appropriate warnings to consumers. The Daughetees argue that defendants cannot avail themselves of the intermediary user defense because they failed to fully communicate the possible hazards of their butter

flavorings to General Mills and ConAgra and therefore could not reasonably rely on General Mills and ConAgra to provide appropriate warnings.

***870** In *Nationwide Agribusiness Ins. Co. v. SMA Elevator Constr., Inc.*, 816 F.Supp.2d 631, 653-54 (N.D. Iowa 2011), I specifically found that:

“intermediary” defense is still viable under Iowa law. ... Restatement (Third) § 2(c) and comment i recognize a defense to a warning defect claim based on the duty of an intermediary—and not even necessarily a “learned” or “sophisticated” intermediary—to warn the end user. Section 2 expressly considers whether “the foreseeable risks of harm posed by the product could have been reduced or avoided by the provision of reasonable instructions or warnings by the seller or other distributor, or a predecessor in the commercial chain of distribution.”

[fn] Comment i distills down to three non-exclusive factors the considerations set out at length in Comment n for determining when a warning to an intermediary is sufficient.

***871** I conclude, taking the facts in the light most favorable to the Daughetees, the non-moving party, *see Torgerson*, 643 F.3d at 1042–43, that a reasonable juror could reject application of defendants’ “intermediary” defense. Significantly, a reasonable juror could conclude that defendants’ butter flavorings containing diacetyl were dangerous products if inhaled. Moreover, a reasonable juror could conclude that the likelihood that the intermediaries, General Mills and ConAgra, would convey the information to the ultimate user was greatly reduced or eliminated if defendants withheld information concerning the dangers posed by their butter flavorings from General Mills and ConAgra. General Mills and ConAgra could not be relied on as reasonable conduits for the necessary information concerning defendants’ butter flavorings if defendants were not first forthcoming to them about the respiratory dangers posed by their products. Finally, a reasonable juror could conclude that placing an adequate warning on microwave popcorn products containing defendants butter flavorings would not be burdensome. There is no material in the summary judgment record that either General Mills or ConAgra were likely to refuse placement of a warning on their microwave popcorn product.

Therefore, this portion of defendants’ motion for summary judgment on the failure-to-warn claims is also denied. [***]

2. Proximate cause

Defendants also seek summary judgment on the Daughetees’ failure to warn claims on the grounds that the Daughetees cannot establish that defendants’ failure to warn Deborah was the proximate cause of her lung condition. ...

a. Proximate cause requirement

[***]“ In products liability, the plaintiff must prove his or her injuries were proximately caused by an item manufactured or supplied by the defendant.” *Spaur v. Owens–Corning Fiberglas Corp.*, 510 N.W.2d 854, 858 (Iowa 1994); [***]. It is well-settled that questions of “proximate cause are ordinarily for the jury,” and “only in exceptional cases should they be decided as a matter of law.” *Thompson v. Kaczinski*, 774 N.W.2d 829, 832 (Iowa 2009) (quoting *Clinkscapes v. Nelson Sec., Inc.*, 697 N.W.2d 836, 841 (Iowa 2005)) [***]

This is not an “exceptional” case. “In the context of a failure to warn claim, proximate cause can be established by showing a warning would have altered the plaintiff’s conduct so as to avoid injury.” ... There is no material in the summary judgment record that *873 Deborah would have ignored a warning to avoid breathing in the vapors from a freshly popped bag of microwave popcorn. A reasonable juror could conclude that a person would not risk permanent, severe lung damage in order to enjoy breathing in the buttery smelling vapors from microwave popcorn if warned about possible serious consequences. There is also no material in the summary judgment record that either General Mills or ConAgra were likely to refuse placement of a reasonable warning on their microwave popcorn product. [***] Given these circumstances, I conclude that questions of proximate cause, here, are for the jury to determine and deny this portion of defendants’ motion for summary judgment. ...

C. Breach Of Implied Warranty Claims

Defendants also seek summary judgment on the Daughetees’ breach of implied warranty claims.

1. Are implied warranty claims redundant?

Defendants argue that the Daughetees’ breach of implied warranty claims in Count II are redundant with their negligence claims found in Count I. Defendants argue that to submit both claims to the jury will generate confusion and may well lead to inconsistent verdicts. The Daughetees respond that, under Iowa law, both claims may be asserted in the same case. [***] The Iowa Supreme Court ... has clearly stated that “personal injury plaintiffs are permitted to seek recovery under tort and warranty theories that in essence allege the same wrongful acts.” *Wright*, 652 N.W.2d at 181; *see Mercer*, 616 N.W.2d at 621 (holding no error in submitting personal injury claims under both strict liability and breach of warranty theories); *see also Lovick*, 588 N.W.2d at 698 (stating that although claims for negligence, strict liability, and breach of warranty are separate and distinct theories of liability under products liability law, the same facts often give rise to those three claims). Thus, the Daughetees’ negligence claims and implied warranty claims are not redundant. I also note that the risks of jury confusion can be alleviated by instructions to the jury during trial and the manner in which the Daughetees’ claims are submitted to the jury for deliberation. Accordingly, I deny this portion of defendants’ motion for summary judgment.

2. Proof of a product defect

Defendants also argue that the Daughetees have offered no proof of a product defect, and, therefore, their breach of implied warranty claims fail as a matter of law. The Daughetees respond that they have adduced sufficient evidence to prevail on a breach of implied warranty claim based on either a failure to warn or a design defect.

a. Defective because of inadequate warnings

Defendants assert that the Daughetees’ implied warranty claims based on inadequate warnings fail because they had no duty to warn Deborah about the dangers associated with their butter flavorings. The Daughetees dispute defendants’ assertion. Both parties reassert all of their arguments addressed above concerning the Daughetees’ failure to warn claims. For the reasons stated at length above, I conclude genuine issues of material fact have been generated on whether defendants knew or had reason to know that their butter flavorings posed a potential risk, at some level, to consumers, thus

triggering the necessity for a warning. Therefore, this portion of defendants' motion for summary judgment is denied.

***876 b. Defective design**

The Iowa Supreme Court has explained that, “[t]o succeed under [Restatement (Third)] section 2(b), a plaintiff must ordinarily show the existence of a reasonable alternative design, *Wright*, 652 N.W.2d at 169, and that this design would, at a reasonable cost, have reduced the foreseeability of harm posed by the product[,] Restatement § 2 cmt. d.” *Parish v. Jumpking, Inc.*, 719 N.W.2d 540, 543 (Iowa 2008); accord *Scott*, 774 N.W.2d at 506 (“The Third Products Restatement section 2, as adopted in *Wright*, requires plaintiffs in design defect cases to demonstrate the existence of a reasonable alternative design.”). Defendants assert that the Daughetees’ implied warranty claims based on defective designs fail because they have offered no evidence of a reasonable alternative design. The Daughetees contend that defendants’ assertion is untrue and that they have put forward evidence that diacetyl-free butter flavorings was a viable alternative design. A review of those materials belies that claim. None of the materials cited by the Daughetees supports the proposition that defendants have or could have produced diacetyl-free butter flavorings. Thus, I find that the materials submitted by the Daughetees are insufficient for a jury to conclude that a reasonable alternative design was available to butter flavorings with diacetyl. Accordingly, this portion of defendants’ motion for summary judgment is granted. [***]

D. Symrise Butter Flavor in ConAgra Microwave Popcorn

Defendant Symrise also seeks summary judgment on the Daughetees’ claims as they relate to Dragoco butter flavorings contained in ConAgra ACT II Butter Lover’s microwave popcorn. Symrise asserts that the Daughetees cannot prove that her lung disease was caused by Dragoco butter flavorings contained in ConAgra ACT II Butter Lover’s microwave popcorn. Symrise argues that Dragoco only provided butter flavorings containing diacetyl to ConAgra for a short time in the early 1990’s and that the amount of Dragoco’s butter flavorings used in ConAgra’s ACT II Butter Lover’s microwave popcorn is unknown. As a result, Symrise argues that Deborah’s exposure levels to it are ***877** speculative and cannot support a finding of causation. Symrise further argues that any claim based on Deborah’s exposure to Dragoco butter flavorings contained in ConAgra ACT II Butter Lover’s microwave popcorn is barred under Iowa’s statute of repose, Iowa Code § 614.1.

The Daughetees respond that Dragoco’s butter flavorings are not the only butter flavorings containing diacetyl that Symrise supplied and that Deborah’s cumulative exposure to Symrise’s products is sufficient to generate a genuine issue of material fact with respect to causation. The Daughetees also argue that Iowa’s statute of repose does not bar their claims because of Iowa’s discovery rule. [c]

Symrise’s statute of repose argument requires me to explain Iowa’s statute of repose, Iowa Code § 614.1, and its discovery rule exception found in Iowa Code § 614.1(2A)(b). See *Great Plains Trust Co. v. Union Pac. R.R. Co.*, 492 F.3d 986, 992 (8th Cir.2007) [***] Iowa’s statute of repose contains the following relevant provisions:

Actions may be brought within the times herein limited, respectively, after their causes accrue, and not afterwards, except when otherwise specially declared:

....

2A. With respect to products.

a. Those founded on the death of a person or injuries to the person or property brought against the manufacturer, assembler, designer, supplier of specifications, seller, lessor, or distributor of a product based upon an alleged defect in the design, inspection, testing, manufacturing, formulation, marketing, packaging, warning, labeling of the product, or any other alleged defect or failure of whatever nature or kind, based on the theories of strict liability in tort, negligence, or breach of an implied warranty shall not be commenced more than fifteen years after the product was first purchased, leased, bailed, or installed for use or consumption unless expressly warranted for a longer period of time by the manufacturer, assembler, designer, supplier of specifications, seller, lessor, or distributor of the product. This subsection shall not affect the time during which a person found liable may seek and obtain contribution or indemnity from another person whose actual fault caused a product to be defective. This subsection shall not apply if the manufacturer, assembler, designer, supplier of specifications, seller, lessor, or distributor of the product intentionally misrepresents facts about the product or fraudulently conceals information about the product and that conduct was a substantial cause of the claimant's harm.

b. (1) The fifteen-year limitation in paragraph "a" shall not apply to the time period in which to discover a disease that is latent and caused by exposure to a harmful material, in which event the cause of action shall be deemed to have accrued when the disease and such disease's cause have been made known to the person or at the point the person should have been aware of the disease and such disease's cause. This subsection shall not apply to cases governed by subsection 11 of this section.

(2) As used in this paragraph, "harmful material" means silicone gel breast implants, which were implanted prior to July 12, 1992; and chemical substances commonly known as asbestos, dioxins, tobacco, or polychlorinated biphenyls, *878 whether alone or as part of any product; or any substance which is determined to present an unreasonable risk of injury to health or the environment by the United States environmental protection agency pursuant to the federal Toxic Substance Control Act, 15 U.S.C. § 2601 et seq., or by this state, if that risk is regulated by the United States environmental protection agency or this state. IOWA CODE § 614.1(2A).

A statute of repose runs from the time the product is first purchased and not from the time harm is first suffered. In other words, "a statute of limitations runs from the accrual of a cause of action, whereas a statute of repose runs from a different, earlier date." *Albrecht v. General Motors Corp.*, 648 N.W.2d 87, 90 (Iowa 2002). Thus, Iowa Code § 614.1(2A) is "clearly [a] statute[] of repose." *Id.* at 92.

The Daughetees do not dispute that their claims fall within the ambit of this statute of repose. Rather, they argue that their claims are allowed by an exception provided for in the statute. Specifically, the exception in § 614.1(2A)(b)(1) for the discovery of latent disease caused by exposure to a "harmful material." However, the term harmful material is specifically defined as: (1) "silicone gel breast implants, which were implanted prior to July 12, 1992;" (2) "chemical substances commonly known as asbestos, dioxins, tobacco, or polychlorinated biphenyls, whether alone or as part of any product;" or (3) "any substance which is determined to present an unreasonable risk of injury to health or the

environment by the United States environmental protection agency pursuant to the federal Toxic Substance Control Act, 15 U.S.C. § 2601 et seq., or by this state, if that risk is regulated by the United States environmental protection agency or this state.” IOWA CODE § 614.1(2A)(b)(2).

The harmful material at issue here is diacetyl. In order for diacetyl to fall within the third category of harmful materials, it must have been determined by either the United States EPA, pursuant to the federal Toxic Substance Control Act, 15 U.S.C. § 2601, or Iowa, to “present an unreasonable risk of injury to health or the environment” and that risk must be regulated by the United States EPA or Iowa. Diacetyl is not classified as harmful material by either the United States EPA or Iowa. To the contrary, it is listed as a food ingredient that is generally recognized as safe for human consumption. *See* 21 C.F.R. § 184.1278. Accordingly, no statutory exception applies and the Daughetees’ claims are subject to Iowa’s fifteen year statute of repose. Deborah first consumed or purchased ConAgra ACT II Butter Lover’s microwave popcorn containing Dragoco butter flavorings with diacetyl in 1992. The Daughetees’ filed their initial complaint on December 8, 2009, more than fifteen years after Deborah first purchased ConAgra ACT II Butter Lover’s microwave popcorn containing Dragoco butter flavorings with diacetyl. Thus, the Daughetees’ claims as to ConAgra ACT II Butter Lover’s microwave popcorn containing Dragoco butter flavorings with diacetyl are barred under Iowa’s statute of repose.

Therefore, Symrise’s Motion For Summary Judgment As To Plaintiff’s Alleged Exposure To Symrise Butter Flavor In ConAgra Microwave Popcorn is granted.

Note 1. Why was the theory of design defect rejected? Not that you will ever eat microwave popcorn again most likely (#bronchiolitisobliterans) but do you agree with the court’s resolution of this issue? What more would you need to know?

Note 2. In the context of this fact pattern, practice identifying for yourself the different ways that a plaintiff can recover in products liability law (express warranty, implied warranty, and the three kinds of action rooted in defects). You can see that the court may blend them to some extent, but it is helpful to try to keep the theories distinct. Can you see some of the reasons why? What facts would you need to change to bring this case within the scope of the other products liability actions?

Note 3. The case illustrates how a statute of repose may limit the plaintiff’s ability to recover. What do you think, *normatively*, of the role the statute plays in *Daughete*? How would a statute of limitation operate here, in contrast?

MODULE 6. DAMAGES

Tort law aims to compensate victims for the actual expenses incurred in connection with losses and injuries suffered due to the tortious conduct of others. The idea is **compensatory in nature**, but also aimed at achieving fairness and efficiency through risk allocation, loss distribution and identifying “deep pockets” (who can best pay and/or internalize the costs). While damages undoubtedly **deter** unreasonable behavior to some extent, the force of deterrence may be different in the civil law context of torts. In the criminal context, by contrast, unsuccessful defendants may face financial penalties but also risk social judgment, severe impact on employment prospects, potential loss of voting rights and of course loss of liberty through imprisonment. In tort law, the deterring factors are different and arguably weaker; it is the fact and size of money damages that is thought to induce fear (or simply caution) on the part of potential tortfeasors.

In some cases, significant reputational harms attach, beyond and discrete from the financial burden imposed by money damages. For instance, the defendant in a professional malpractice case may find that paying a damages award does less harm to their ongoing and future business prospects than the simple fact that their negligent professional conduct has been brought to light. Depending on the industry as well as the extent of the malpractice, the legal ruling could make continued participation in the profession all but impossible. Hence reputational interests may also play a role in bolstering tort law’s rules, apart from the anticipated impact of damages. However, in a great many cases, corporations and businesses treat tort liability as a cost of doing business. Such entities don’t really care how tort liability makes them appear to the public. To invoke (and again paraphrase) Judge Richard Posner’s point, perhaps some accidents aren’t worth the cost of avoiding, or of taking precautions to avoid. Some risk is cheaper to internalize than to prevent. The **negligence calculus (or “Hand formula”)** covered in Module 3 offers a way to approach determinations of negligence by juxtaposing the costs of taking precautions against the likelihood and severity of harm that will flow if the precautions are not taken. Another way of putting this is that the defendant may have acted reasonably from an economic perspective even when choosing not to take some precautions that would definitely have minimized some injuries.

Finally, in a small number of cases, plaintiffs aren’t seeking money damages, they’re seeking some form of injunctive relief, more like a property remedy. They may wish to stop their neighbor from using part of their land for some objectionable purpose or they may wish to force a company to stop polluting a community’s water source. But in most tort disputes, the remedy at hand is money.

A signal feature of the tort law system is its view that money damages can compensate victims for some amount of their pain and suffering even above and beyond paying for the literal costs of the tortfeasance. Recall from Modules 1 and 2 that tort law barred or restricted recovery for purely emotional harms. Damages for emotional distress have a special character that tracks this historical reluctance. For one thing, such damages are harder to articulate and prove than purely financial losses, which tend to be fairly straightforward to prove. (This is true for past financial losses; projecting future losses can be a good deal more complicated.)

For numerous reasons, courts tend to separate the questions of liability (will this defendant be liable to this plaintiff on account of the defendant’s alleged wrongdoing) distinct from damages (how much will

the defendant be required to pay this plaintiff in light of the defendant's liability). Most trials bifurcate into separate liability and damages phases and, as with so many parts of tort law, the jury plays a significant role in determinations of damages. Even in trials that do not bifurcate, the jury will almost always be given separate verdict forms for the liability and damages verdicts, reflecting the importance of continuing to keep distinct from each other the questions of liability and damages.

Several kinds of damages exist. **Nominal damages** are largely symbolic and awarded by a judge to clarify parties' positions or vindicate an interest even where money damages do not attach or additional harms have not been proven (as you saw in Modules 1 and 2 with respect to battery and trespass). The court may order \$1 or instruct the losing part to pay court costs, for example (which are much smaller than legal fees; those require a different showing and are infrequently awarded). The purpose of nominal damages is to clarify the parties respective interests and/or show that the defendant committed the tort, which will presumably cause a change in behaviors going forward.

Compensatory damages exist to repay the plaintiff for the expenses they have incurred as a result of the tortfeasor's conduct. These awards, when made for expenses associated with physical injuries, are not usually treated as taxable income. Instead, they are analogous to a reimbursement of expenses that would not have been incurred but for the defendant's breach of due care. Such damages are thought to be the best approximation of what the P actually suffered, that is, the means of "making the plaintiff whole again." Compensatory damages are by far the most common kind of damages encountered in tort litigation.

There are two types of compensatory damages: pecuniary (or financial) and non-pecuniary losses. Pecuniary losses may include damage to property and the costs to repair or replace (as well as costs associated with temporary substitution such as a rental car or home during the pendency of repairs). Pecuniary losses may also include the costs associated with personal injury damages including present and relevant future medical expenses; lost wages and/or future diminished earning capacity as well as any other economic costs associated with the physical injury, including any other economic expenses incurred because of the injury (think of transportation; maybe the plaintiff can no longer drive and will require buses, taxis, or a specially outfitted vehicle). When lost wages are awarded, they are ordinarily taxed in the way that employment compensation would have been. Other exceptions apply and the rules are both complex and liable to change with various tax reforms. However, it can be a helpful dividing line conceptually for students to think of compensatory damages as being the amount that plaintiffs proved they had spent for their suffering or persuaded the trier of fact that their suffering was "worth." Punitive damages differ in being additional to that baseline amount. All of those pecuniary losses are sometimes called "special damages" and distinguished from "general damages" which are awarded in connection with pain and suffering.

General damages are sometimes harder to quantify but they are not controversial when allocated in connection with physical injury. Some jurisdictions have created statutory caps on damages and those that do may cap general damages in particular. They are associated with potentially arbitrary and excessive awards because they may lack the specific and trackable character of special damages. Note that the defendant's conduct does not control the amount of the plaintiff's compensatory damages. The damages are based on the plaintiff's injury because these damage awards aim to restore the plaintiff to a pre-accident state. In that sense, compensatory damages reflect the commitments underlying the eggshell plaintiff doctrine.

By contrast, **punitive damages** exist only in extraordinary cases and the plaintiff must prove that the defendant's conduct was not merely unreasonable (which was established in the liability phase of the trial) but also included something like "malice" or "wanton or willful violence" (the precise standard varies by jurisdiction). These are damages intended to deter and punish egregious conduct. Unlike compensatory damages, punitive damages are taxable by default because they are considered to be extra compensation, beyond the remuneration the plaintiff needs to be whole again. They are sometimes used for amounts that might not otherwise be recoverable such as attorney's fees or time lost litigating (especially in bitter litigation with a vindictive or trivial aspect to it). Most often awards of punitive damages go straight to the plaintiff. However, in some states, because these awarding of punitive damages is thought to be similar in purpose to criminal punishment and the plaintiff does not need them, awards of punitive damages may go to the state. These damages are always permissive, not mandatory—that is, they are discretionary for the jury and never awarded automatically. In some instances, such as in cases of vicarious liability in claims arising under the FTCA, punitive damages are unavailable.

Questions or Areas of Focus for the Reading

- Are damages truly intended to "make P whole again"? Is this a subjective standard?
- If so, why are juries told to make "fair and *reasonable*" awards?
- Should the language of "wholeness" be abandoned?
- Where do awards for pain and suffering fit in?
- Should punitive damages be subject to the same or different rules and limitations as compensatory damages?
- Why does the system require proof of harm in some cases, and not others?
- Why does the system take some kinds of harm more seriously than others?
- Are statutory caps on damages (which have been ruled constitutional) undercutting the compensation principle?
- Consider what interests or experiences, if any, strike you as being impossible to remedy through money damages. Is there anything tort law can do to improve a situation in such cases?
- Doctrines provide one level of understanding of tort's damages scheme. As you read, consider the sociological factors that may play a role in effectuating (or undermining) tort law's purposes with respect to money damages.

Chapter 32. Punitive Damages

Most cases are *not* about punitive damages. While cases featuring punitive damages seek to punish, and thus to deter, the majority of cases center instead on compensating plaintiffs for their suffering and losses. Nonetheless, punitive damages play an important role in shaping behavior even through the *possibility* that they may be sought. They also define a boundary between more and less conventionally tortious conduct. Accordingly, they merit discussion for their ongoing role in shaping tort policy. The behavior associated with punitive damages must be reprehensible, not just irresponsible and unreasonable (“The most important indicium of the reasonableness of a punitive damages award is the degree of reprehensibility of the defendant’s conduct.” *BMW of North America, Inc. v. Gore*, 517 U.S. 559, 575 (1996)). In tort law, “reprehensibility” may mean looking for conduct that is “wanton and willful” or that “shocks the conscience”; diverse formulations exist depending on the jurisdiction. These determinations will require an extra showing in addition to merely proving liability and damages. In many cases, courts use a separate verdict form to determine the existence and amount of any punitive damages.

The next case, featuring an opinion by Judge Richard Posner, reviews the most commonly deployed rationales for punitive damages.

Kemezy v. Peters, United States Court of Appeals, Seventh Circuit (1996) (79 F.3d 33)

Jeffrey Kemezy sued a Muncie, Indiana policeman named James Peters under 42 U.S.C. § 1983, claiming that Peters had wantonly beaten him with the officer’s nightstick in an altercation in a bowling alley where Peters was moonlighting as a security guard. The jury awarded Kemezy \$10,000 in compensatory damages and \$20,000 in punitive damages. Peters’ appeal challenges only the award of punitive damages, and that on the narrowest of grounds: that it was the plaintiff’s burden to introduce evidence concerning the defendant’s net worth for purposes of equipping the jury with information essential to a just measurement of punitive damages. [***]

The standard judicial formulation of the purpose of punitive damages is that it is to punish the defendant for reprehensible conduct and to deter him and others from engaging in similar conduct. [cc] This formulation is cryptic, since deterrence is a purpose of punishment, rather than, as the formulation implies, a parallel purpose, along with punishment itself, for imposing the specific form of punishment that is punitive damages. [***] A review of the reasons will point us toward a sound choice between the majority and minority views.

1. Compensatory damages do not always compensate fully. Because courts insist that an award of compensatory damages have an objective basis in evidence, such awards are likely to fall short in some cases, especially when the injury is of an elusive or intangible character. If you spit upon another person in anger, you inflict a real injury but one exceedingly difficult to quantify. If the court is confident that the injurious conduct had no redeeming social value, so that “overdeterring” such conduct by an

“excessive” award of damages is not a concern, a generous award of punitive damages will assure full compensation without impeding socially valuable conduct.

2. By the same token, punitive damages are necessary in such cases in order to make sure that tortious conduct is not underdeterred, as it might be if compensatory damages fell short of the actual injury inflicted by the tort.

These two points bring out the close relation between the compensatory and deterrent objectives of tort law, or, more precisely perhaps, its rectificatory and regulatory purposes. Knowing that he will have to pay compensation for harm inflicted, the potential injurer will be deterred from inflicting that harm unless the benefits to him are greater. If we do not want him to balance costs and benefits in this fashion, we can add a dollop of punitive damages to make the costs greater.

3. Punitive damages are necessary in some cases to make sure that people channel transactions through the market when the costs of voluntary transactions are low. We do not want a person to be able to take his neighbor’s car and when the neighbor complains tell him to go sue for its value. Guido Calabresi & A. Douglas Melamed, “Property Rules, Liability Rules, and Inalienability: One View of the Cathedral,” 85 *Harv. L. Rev.* 1089, 1124–27 (1972). We want to make such expropriations valueless to the expropriator *35 and we can do this by adding a punitive exaction to the judgment for the market value of what is taken. This function of punitive damages is particularly important in areas such as defamation and sexual assault, where the tortfeasor may, if the only price of the tort is having to compensate his victim, commit the tort because he derives greater pleasure from the act than the victim incurs pain.

4. When a tortious act is concealable, a judgment equal to the harm done by the act will underdeter. Suppose a person who goes around assaulting other people is caught only half the time. Then in comparing the costs, in the form of anticipated damages, of the assaults with the benefits to him, he will discount the costs (but not the benefits, because they are realized in every assault) by 50 percent, and so in deciding whether to commit the next assault he will not be confronted by the full social cost of his activity.

5. An award of punitive damages expresses the community’s abhorrence at the defendant’s act. We understand that otherwise upright, decent, law-abiding people are sometimes careless and that their carelessness can result in unintentional injury for which compensation should be required. We react far more strongly to the deliberate or reckless wrongdoer, and an award of punitive damages commutes our indignation into a kind of civil fine, civil punishment.

Some of these functions are also performed by the criminal justice system. Many legal systems do not permit awards of punitive damages at all, believing that such awards anomalously intrude the principles of criminal justice into civil cases. Even our cousins the English allow punitive damages only in an excruciatingly narrow category of cases. See, e.g., *AB v. South West Water Services Ltd.*, [1993] 1 All E.R. 609 (Ct.App.1992). But whether because the American legal and political cultures are unique, or because the criminal justice system in this country is overloaded and some of its functions have devolved upon the tort system, punitive damages are a regular feature of American tort cases, though reserved generally for intentional torts, including the deliberate use of excess force as here. This suggests additional functions of punitive damages:

6. Punitive damages relieve the pressures on the criminal justice system. They do this not so much by creating an additional sanction, which could be done by increasing the fines imposed in criminal cases, as by giving private individuals—the tort victims themselves—a monetary incentive to shoulder the costs of enforcement.

7. If we assume realistically that the criminal justice system could not or would not take up the slack if punitive damages were abolished, then they have the additional function of heading off breaches of the peace by giving individuals injured by relatively minor outrages a judicial remedy in lieu of the violent self-help to which they might resort if their complaints to the criminal justice authorities were certain to be ignored and they had no other legal remedy.

What is striking about the purposes that are served by the awarding of punitive damages is that none of them depends critically on proof that the defendant's income or wealth *exceeds* some specified level. The more wealth the defendant has, the smaller is the relative bite that an award of punitive damages not actually geared to that wealth will take out of his pocketbook, while if he has very little wealth the award of punitive damages may exceed his ability to pay and perhaps drive him into bankruptcy. To a very rich person, the pain of having to pay a heavy award of damages may be a mere pinprick and so not deter him (or people like him) from continuing to engage in the same type of wrongdoing. *Zazú Designs v. L'Oréal, S.A.*, 979 F.2d 499, 508 (7th Cir. 1992) *Zazú Designs v. L'Oréal, S.A.*, *supra*, 979 F.2d at 508. What in economics is called the principle of diminishing marginal utility teaches, what is anyway obvious, that losing \$1 is likely to cause less unhappiness (disutility) to a rich person than to a poor one. (This point, as the opinion in *Zazú Designs* emphasizes, does not apply to institutions as distinct from natural persons. *Id.* at 508–09.)

But rich people are not famous for being indifferent to money, and if they are forced to pay not merely the cost of the harm to the victims of their torts but also some multiple of that cost they are likely to think twice before engaging in such expensive *36 behavior again. Juries, rightly or wrongly, think differently, so plaintiffs who are seeking punitive damages often present evidence of the defendant's wealth. The question is whether they *must* present such evidence—whether it is somehow unjust to allow a jury to award punitive damages without knowing that the defendant really is a wealthy person. The answer, obviously, is no. A plaintiff is not required to seek punitive damages in the first place, so he should not be denied an award of punitive damages merely because he does not present evidence that if believed would persuade the jury to award him even more than he is asking.

Take the question from the other side: if the defendant is not as wealthy as the jury might in the absence of any evidence suppose, should the plaintiff be required to show this? That seems an odd suggestion too. The reprehensibility of a person's conduct is not mitigated by his not being a rich person, and plaintiffs are never required to apologize for seeking damages that if awarded will precipitate the defendant into bankruptcy. A plea of poverty is a classic appeal to the mercy of the judge or jury, and why the plaintiff should be required to make the plea on behalf of his opponent eludes us.

The usual practice with respect to fines is not to proportion the fine to the defendant's wealth, but to allow him to argue that the fine should be waived or lowered because he cannot possibly pay it. [***] Given the close relation between fines and punitive damages, this is the proper approach to punitive damages as well. The defendant who cannot pay a large award of punitive damages can point this out to the jury so that they will not waste their time and that of the bankruptcy courts by awarding an amount that exceeds his ability to pay.

It ill becomes *defendants* to argue that plaintiffs *must* introduce evidence of the defendant's wealth. Since most tort defendants against whom punitive damages are sought are enterprises rather than individuals, the effect of such a rule would be to encourage plaintiffs to seek punitive damages whether or not justified, in order to be able to put before the jury evidence that the defendant has a deep pocket and therefore should be made to pay a large judgment regardless of any nice calculation of actual culpability. (The judge might not allow this, if persuaded by the suggestion in *Zazú Designs* that the defendant's net worth is irrelevant to the size of the award of punitive damages when the defendant is a corporation or other institution rather than an individual.) Individual defendants, as in the present case, are reluctant to disclose their net worth in any circumstances, so that compelling plaintiffs to seek discovery of that information would invite a particularly intrusive and resented form of pretrial discovery and disable the defendant from objecting. Since, moreover, information about net worth is in the possession of the person whose net worth is in issue, the normal principles of pleading would put the burden of production on the defendant—which, as we have been at pains to stress, is just where defendants as a whole would want it.

Peters argues that a defendant who presents evidence of his net worth to the jury in an effort to minimize any award of punitive damages will be understood by the jury to be conceding the appropriateness of awarding punitive damages in at least the amount suggested by the defendant. This is just the kind of thinking that has so often led defendants into disaster when they decided not to put into evidence their own estimate of the damages to which the plaintiff was entitled, but instead played the equivalent of double or nothing. [c] Most jurors should be able to understand the structure of an argument to the effect that the defendant does not concede liability, let alone liability for punitive damages, but that if the jury disagrees it should award only a nominal amount of punitive damages because the defendant is a person of limited means.

***37** The defendant should not be allowed to plead poverty if his employer or an insurance company is going to pick up the tab. [cc] The contrary argument, accepted in *Michael v. Cole*, 122 Ariz. 450, 452 (1979), that the insurance contract is a purely private matter between the defendant and his insured, ignores the consequence of such a view for the deterrent efficacy of punitive damages. It is bad enough that insurance or other indemnification reduces the financial incentive to avoid wrongdoing—which is why insuring against criminal liability is prohibited. It would be worse if the cost of the insurance fell, reducing the financial disincentive to engage in wrongful behavior, because the insurance company knew that its insured could plead poverty to the jury.

We were told by Peters' lawyer without contradiction that Peters will not be indemnified for the punitive damages that he has been ordered to pay. We have noted the inappropriateness of allowing the defendant to plead poverty if he will be indemnified not because such a plea was attempted here, but to underscore the anomaly of requiring plaintiffs seeking punitive damages always to put in evidence of the defendant's net worth. When the defendant is to be fully indemnified, such evidence, far from being required, is inadmissible. Thus, in some cases it is inadmissible, but in no cases is it required.

AFFIRMED.

Note 1. What is the legal issue in this case? What is the holding?

Note 2. How does Judge Posner describe the interrelationship between the compensatory and punitive functions of damages awards?

Note 3. Are punitive damages efficient, according to Judge Posner? How about fair? Do you agree with his reasoning?

Note 4. Judge Posner offers a theory of punitive damages that suggests interplay between the torts and criminal systems. What do you think, descriptively and normatively, of using tort law as a kind of backstop or complement to criminal law?

Note 5. There are certain predictable pitfalls and areas of confusion involved in punitive damages. One is the use of the word “malice.” Make a mental note now to use and interpret the word differently in each new context in which it arises in your legal education. “Malice” plays a different role in criminal law, and a different role even within tort law, where “actual malice” holds a special meaning for defamation jurisprudence. Another area of complexity in punitive damages involves intent. In setting a higher culpability standard, some states require proof of “willful and wanton” conduct. Iowa, for example, defines that standard as follows:

[T]he actor has *intentionally* done an act of an *unreasonable* character in disregard of a known or obvious risk that was so great as to make it *highly probable that harm* would follow, and which thus is usually accompanied by a *conscious indifference to the consequences* [emphasis supplied]. *Daughetee v. Chr. Hansen Inc.*, U.S. District Court Iowa, Western Division, 960 F. Supp.2d 849, 879 (2013)

The language may seem to confound the distinction between negligence and the intentional torts, yet it is important to keep the two domains distinct. First, there are enduring differences in the facts needed to prove the various torts that will continue to make the distinction between these regimes significant. Second, the willful and wanton standard cited above applies to the *level* of liability, and thus arises in the damages phase of the trial; it does not apply to the *fact* of liability and its determination is thus not dispositive of the liability phase of the trial. Put another way, a plaintiff may win on liability and receive all the compensatory damages sought but lose on the request for punitive damages.

Check Your Understanding (6-1)

Question 1. True or false: If the defendant’s conduct is malicious (satisfying the “malice,” or “wanton and willful disregard of safety” standard), punitive damages will definitely be granted.

An interactive H5P element has been excluded from this version of the text. You can view it online here: <https://saidtorts2d.lawbooks.cali.org/?p=93#h5p-117>

Question 2. True or False: Specific intent—the intent to cause harm in the realm of intentional torts—satisfies the standard required for punitive damages in most states.

An interactive H5P element has been excluded from this version of the text. You can view it online here: <https://saidtorts2d.lawbooks.cali.org/?p=93#h5p-118>

Chapter 33. Compensatory Damages

Villa v. Derouen Court of Appeal of Louisiana, Third Circuit (1993) (614 So.2d 714)

[Recall the fact pattern from this case covered in Module 2 under Intent.]

Villa sustained second degree burns to his penis, scrotum, and both thighs. He was first seen by Dr. James Falterman, Sr. on May 8, 1986, who hospitalized him from May 8, 1986, through May 16, 1986. Dr. Falterman testified that Villa was reasonably comfortable, with pain medication and treatment, within three (3) to four (4) days and, at a maximum, within one (1) week after the accident. Villa's physical wounds healed completely, with some depigmentation, but no functional disability. He was discharged from treatment of his burns as of June 20, 1986.

Villa complained of being nervous and depressed on May 15, of 1986, and requested to see a psychiatrist. Villa was referred by Dr. Falterman to Dr. Warren Lowe, a clinical psychologist, who first saw Villa on June 9, 1986. Dr. Lowe diagnosed Villa as suffering from atypical anxiety disorder with depressive features together with some symptoms of post-traumatic stress disorder. At the time of trial, Dr. Lowe felt that Villa was getting better and was capable of entering a rehabilitation program.

Dr. Lowe's partner, Dr. Jim Blackburn, was offered as an expert in psychiatry. He saw Villa in August of 1986 and again, saw Villa and his wife on January 26, 1988. He diagnosed Villa as suffering from a major depression with some elements of post-traumatic stress. He felt that Villa was a very good candidate for rehabilitation and believed that Villa would make a good recovery and be able to resume a normal functional life. At the time of trial, in April of 1990, Villa had not, as yet, returned to work and remained nervous about returning to work.

Total medicals paid by Liberty Mutual, the worker's compensation insurer of M.A. Patout and Sons, Inc., Villa's employer, up to the time of trial were \$14,300.00.

Glenn Hebert, a vocational rehabilitation specialist, testified that Villa was ready for and would need several years of rehabilitation counseling and/or retraining to build up his self-esteem and self-respect, and to recover from his loss of trust in people. He testified that a vocational school would cost approximately \$2,000.00 for two (2) years, while concurrent counseling would cost about \$900.00 per month, which would total \$21,600.00 for twenty-four (24) months of counseling. This would total \$23,600.00 for rehabilitation. Hebert also testified that Villa needs to go to work but would recommend conditions where he can work part-time, alone or with one other person.

Dr. Cornwell, an expert economist, testified that Villa has suffered a \$57,907.00 loss of earnings from the date of the accident until trial. This figure is based upon an annual pre-accident wage of \$14,772.00 per year. If Villa works, as recommended by Hebert, for twenty-five (25) hours per week at \$4.25 per

hour, assuming a two (2) *720 year rehabilitation period, he would have an additional loss of \$18,500.00.¹⁶⁸

At the time of the accident, Villa was earning \$5.75 per hour and should be able to earn that or more with the benefit of two (2) years of rehabilitation. Thus, Villa's total special damages would be:

Medicals

\$14,300.00

Loss of wages:

Pre-trial

\$57,907.00

Post-trial

\$18,500.00

Total Rehabilitation

\$23,600.00

TOTAL SPECIAL DAMAGES

\$114,307.00

We find that a reasonable general damage award for Villa's past and future physical and mental pain and suffering would be \$60,000.00.

CONCLUSION

The jury's verdict finding that Michael Derouen did not commit an intentional tort is hereby reversed.

IT IS HEREBY ORDERED, ADJUDGED AND DECREED that there be judgment in favor of Eusebio Villa and against Michael Derouen and Louisiana Farm Bureau Mutual Insurance Company, Derouen's homeowner insurer, in the amount of ONE HUNDRED FOURTEEN THOUSAND THREE HUNDRED SEVEN AND NO/100 (\$114,307.00) DOLLARS in special damages and SIXTY THOUSAND AND NO/100 (\$60,000.00) DOLLARS in general damages. Judicial interest and costs at trial and on appeal to be paid by Michael Derouen and Louisiana Farm Bureau Mutual Insurance Company.

Note 1. The role of insurance companies can be significant in both the liability and damages phase of trial. What is the significance of the insurance company's role in this case?

Note 2. What do you observe about the determination of special versus general damages? Damage determinations are not meant to be binding on subsequent courts. Courts are guided, of course, by evidence the parties submit regarding damages. However, in some sense, courts or juries come up with the final award amounts "from scratch" in each case since they do not start with prior verdicts or rulings. Courts and trial lawyers may also consult something called a "Schedule of Loss" used in each state to determine the compensation under Workers Compensation claims. It typically lays out the guidelines and amounts for typical injuries so that each time a person suffers a catastrophic loss of a

¹⁶⁸ \$14,770.00 pre-accident annual wage offset by \$5,524.00 per year earned equals an annual loss of \$9,250.00 per year.

thumb or leg, for instance, the calculations of impact on a person's life do not have to begin entirely anew. The loss schedules will require actuarial adjustment and tailoring to a given case, and they may not be admissible directly, depending on the case and jurisdiction. But they may nonetheless play a role in shaping litigation strategy and outcomes.

The aim of “making the plaintiff whole” reflects tort law’s compensation principle, as well as the fiction that money can ever really achieve such a goal. Money damages are usually a very distant second-best option. Even assuming a good-faith desire to try to restore to the plaintiff the state they were in before the tortious conduct, the question of how to do that possesses its own complexities, logistically, and philosophically. What gets counted, who measures and proves that, and what sorts of socioeconomic assumptions and biases influence the process? All of these considerations come to bear in the following FTCA case featuring a woman who was negligently dispensed with a drug that quickly led to her death.

Zuchowicz v. U.S., United States District Court, D. Connecticut (1996) (Not Reported in F. Supp.) (1996 WL 776585)

*1 Plaintiff, Steven F. Zuchowicz, brought this wrongful death action as Executor of the estate of his deceased wife, Patricia Zuchowicz, under the Federal Tort Claims Act, 28 U.S.C. §§ 1346(b), 2671-2680 (“FTCA”). Plaintiff alleged that his wife developed primary pulmonary hypertension (“PPH”) and died as a result of ingesting an excessive amount of the drug Danocrine, dispensed to her at the Naval Submarine Base Naval Hospital in Groton, Connecticut.

This matter was tried to the Court for 16 days principally on the issue of proximate cause.¹⁶⁹ At trial, defendant conceded that its agents or employees negligently prescribed an overdose of Danocrine to the plaintiff’s decedent but denied that this negligence caused her to develop PPH. On July 8, 1996, the Court issued a Memorandum of Decision entering Findings of Fact and Conclusions of Law pursuant to Fed. R. Civ. P. 52(a) finding that plaintiff met his burden of demonstrating that defendant’s negligence caused the decedent’s PPH. The Court instructed the parties to file supplemental briefs regarding damages.

Plaintiff seeks damages for medical and funeral expenses, plaintiff’s decedent’s conscious pain and suffering, lost wages, lost earning capacity and compensation for destruction of life’s enjoyment. In ruling on the damages to be awarded plaintiff, the Court incorporates its Findings of Fact and Conclusions of Law dated July 8, 1996.

Under the FTCA, damages are determined in accordance with the law of the place where the act or omission occurred. 28 U.S.C. § 1346(b). Here, the law of Connecticut governs the issue of damages,

¹⁶⁹ Editor’s Note: the trial took “16 days principally on the issue of proximate cause.” If you’re wondering why we talk about burden-shifting mechanisms, shortcuts to establish negligence, and—most crucially—about whether to limit liability as a matter of duty (*Palsgraf’s* majority) versus doing so as a function of proximate cause (*Palsgraf’s* dissent), this is it, in a nutshell. Facts are resource-intensive to litigate, and juries are resource-intensive to empanel and instruct. 16 days of trial is a long, expensive thing to engage in even when there’s a really compelling case involved.

specifically Conn. Gen. Stat. § 52-555, which creates a cause of action belonging to the decedent during her lifetime which passes to the executor or administrator by right of survival. [***]

Section 52-555 provides in relevant part that an executor or administrator, “may recover from the party legally at fault for such injuries just damages together with the cost of reasonably necessary medical, hospital and nursing services, and including funeral expenses....” “Just damages” include: (1) damages for lost earning capacity less deductions for taxes and necessary living expenses, and discounted to present value; (2) damages for conscious pain and suffering; and (3) compensation for the loss of the capacity to enjoy life’s activities in a way the decedent would have had she lived. [c]

There is no mathematical formula or ironclad rule for assessing damages in a wrongful death case. *Id.* at 657. The trier of fact is required to take all of the evidence and make an intelligent estimate of the appropriate damages. [c] Since no one life is like another, comparing damage awards from other wrongful death cases serves no useful purpose: “the damages for the destruction of one furnish no fixed standard for others.” *Id.* at 661.

Medical and Funeral Expenses

*2 The parties stipulated at trial that plaintiff incurred funeral and “noncovered” medical expenses of \$29,203.51. By the phrase “noncovered,” the Court is referring to medical expenses not paid by CHAMPUS, Mrs. Zuchowicz’s medical insurance carrier. Based on the parties’ agreement and the reasonableness of this amount, the Court will award funeral and non-covered medical expenses in the amount of \$29,203.51.

Lost Wages

Plaintiff seeks lost wages in the amount of \$15,193.46 for the time period between February 18 1989, when Mrs. Zuchowicz was prescribed Danocrine, and December 31, 1991, the date of her death, approximately 34.5 months. Plaintiff arrives at this amount of lost wages by calculating Mrs. Zuchowicz’s average monthly earnings for the years 1987 and 1988 and multiplying this figure by 34.5 months.

Defendant argues that there is no evidence before the Court to reasonably infer Mrs. Zuchowicz’s past wages. To the contrary, the record reveals that Mrs. Zuchowicz was a high school graduate and attended community college for less than one year. In 1987, after training, she became a nurse’s aide working both full-time and part-time hours until January 1989. Also, prior to trial the parties stipulated in their proposed stipulations of fact (doc. # 143) that Mrs. Zuchowicz’s earnings for 1987 and 1988 were \$4301.14 and \$6268.16, respectively. These amounts average out to \$5,284.65 per year or \$440.39 per month. Finally, Mrs. Zuchowicz testified that she was physically incapable of continuing her work as a nurse’s aide after February 18, 1989.

This evidence is sufficient guidance for the Court to determine lost wages. Proof to a mathematical certainty is not required; only evidence that lays a foundation from which the factfinder can estimate a proper award. *Delott v. Roraback*, 179 Conn. 406, 411 (1980). The Court finds appropriate damages for lost wages in the amount of \$15,193.46.

Lost Earning Capacity

In determining a proper award for lost earning capacity in a wrongful death case, the court must inquire into a decedent's capacity or capability to obtain gainful employment at the time of their death and for the remainder of their life. ... The court may take into consideration the decedent's earnings history, qualifications and experience. ... From this amount the court must deduct decedent's probable income tax liability, personal living expenses, and discount the award to its present cash value. ...

Plaintiff has submitted with his brief on damages, the U.S. Department of Health and Human Services, Public Health Service, National Center for Health Statistics, Vital Statistics of the U.S., Vol. II, Sec. 6, as applied in 1988. The Court takes judicial notice from these statistics that plaintiff's decedent, a white female of 31 at the time of her death, had a potential life expectancy of 49.2 years and a work life expectancy of 34 years, or until age 65.

*3 Plaintiff seeks damages for lost earning capacity in the amount of \$89,839.05. In arriving at this amount, plaintiff assumes a base lost earning capacity of \$179,678.10 (\$5,284.65 per year X 34 years). This base amount does not take into account any potential savings from increased earnings or inflation. Plaintiff has then reduced this amount by half to account for potential income tax liability, discounting to present value, personal living expenses and any likelihood that Mrs. Zuchowicz may have left the workplace to care for her children. The Court finds that this is a fair estimate and awards damages for lost earning capacity in the amount of \$89,839.05.

Pain and Suffering

Plaintiff seeks \$1,040,718 for Mrs. Zuchowicz's pain and suffering from February 18, 1989 to December 31, 1991. Plaintiff calculates this award based on the amount awarded by this Court in *Parkins v. United States*, 842 F. Supp. 617, 619-621 (D. Conn. 1993), another FTCA case. However, as the Court noted earlier, comparing awards in other cases serves no useful purpose.

An award for pain and suffering is appropriate in a medical negligence case where evidence has been presented in support. [***] Here, damages for pain and suffering are appropriate.

When initially taking Danocrine, Mrs. Zuchowicz experienced night sweats, a racing heart, chest pains, dizziness and headaches. During the summer of 1989, she continued to have fatigue and chest tightness and pain and began experiencing shortness of breath, which became progressively worse. Mrs. Zuchowicz was diagnosed with PPH in October 1989 after a nine-day hospital stay and several tests, including a pulmonary artery catheterization. She was told she would need a heart and lung transplant. She was treated with Procardia XL, a calcium channel blocker, to which she responded well.

Although aware of her diagnosis and treatment, she testified that she did not learn that her disease was terminal until several months later when she read Dr. Michael Shea's memorandum dated October 14, 1989. This report stated that Mrs. Zuchowicz's prognosis was very poor and that death commonly occurred in patients with PPH within 2-3 years of diagnosis.

After an extensive evaluation and medical screening at the Cleveland Clinic in June 1990, Mrs. Zuchowicz was put on a lung transplant list. She was also informed at that time that she could suffer a sudden death. She underwent counseling to assist her in coping with her condition.

Mrs. Zuchowicz testified that during this time she was able to avoid physical pain and breathe without significant difficulty by limiting her physical activity and avoiding humid conditions. She was unable to participate in any sports activities as she previously had or even climb stairs. She could do light housekeeping, read and garden. In May 1990, she and her husband took a trip to Atlantic City and, several months later, they took a foster child into their home.

*4 Despite past problems with infertility, Mrs. Zuchowicz became pregnant in March 1991. Her physicians advised her that the pregnancy would exacerbate her illness, reduce her lifespan and temporarily disqualify her as a candidate for a lung or heart transplant. During her pregnancy, Mrs. Zuchowicz suffered from numerous complications. While in her third trimester, she began to get increasingly short of breath and blacked out as many as five times a day. On November 21, 1991, Mrs. Zuchowicz delivered a baby boy by Cesarian section approximately 4 ½ weeks early.

On December 17, 1991, Mrs. Zuchowicz's pulmonary condition worsened and she was admitted into the Cleveland Clinic on December 20, 1991, in the hopes of undergoing a single lung transplant. While hospitalized Mrs. Zuchowicz experienced among other things, nausea and hallucinations as well as depression over her inability to care for her child. Her condition became progressively worse and on the morning of December 31, 1991 she was intubated. She died later that afternoon.

Taking into account all of the above factors, the Court finds that an award of \$350,000.00 is reasonable compensation for Mrs. Zuchowicz's pain and suffering.

Loss of Life's Activities

Plaintiff seeks an award of \$4,930,493 for Mrs. Zuchowicz's loss of life's activities, specifically in enjoying her marriage and rearing her son. This amount is again based on the amount awarded in *Parkins*.

Determining damages for the loss of life's activities "with any exactness is ... beset with insurmountable difficulties. The law, nevertheless, undertakes to do justice as best it can, although of necessity crudely." *Lane v. United Elec. Light & Water Co.*, 90 Conn. 35, 37 (1915). Damages are essentially limited to the probable length of life of the deceased had she not died. The trier must also consider the extent to which the "ordinary vicissitudes of life" would have likely affected the decedent's continued enjoyment of her life. *Chase v. Fitzgerald*, 132 Conn. at 469.

By having a child, Mrs. Zuchowicz was able to fulfill her dream of becoming a mother. Due to her untimely death, she was deprived of participating in the rearing of her son. She was also unable to continue her relationship with her husband which, despite many difficulties in the past, became closer during her illness.

The Court finds that damages in the amount of \$550,000 is an appropriate award to compensate for Mrs. Zuchowicz's loss of life's activities.

Based on foregoing [*sic*], damages shall be awarded in the following amounts:

Medical and Funeral Expenses	\$29,203.51
Lost Wages	\$15,193.46
Lost Earning Capacity	\$89,839.05
Pain and Suffering	\$350,000.00
Loss of Life's Activities	\$550,000.00
Total:	\$1,034,236.02

The Clerk is directed to enter judgment in favor of plaintiff accordingly.

Note 1. In your estimation, does tort law take a reasonable approach to determining damages associated with loss of enjoyment of life, and loss of companionship? These so-called “hedonic damages” are intended to try to put a dollar value on the pleasures of a life lived without the intrusion of tortious injury. What occurs to you about how they seem to operate, and what do you think they fail to capture?

Note 2. The court notes that “[b]y having a child, Mrs. Zuchowicz was able to fulfill her dream of becoming a mother. Due to her untimely death, she was deprived of participating in the rearing of her son.” What do you think of the court’s reasoning here? Does it seem unreasonable to plan for a pregnancy and a child in light of significant, known health complications (even if these have been induced by someone else’s tortious conduct)? Who should be accountable for her inability to accept a lung transplant when it became available? Is this an eggshell plaintiff type of situation? Or does it seem reasonable to wish to impose limits on such a pregnancy on the basis of tort law? Did Mrs. Zuchowicz have a duty to mitigate here, even though she was the victim of wrongdoing?

Does the court’s rhetoric reflect any bias, in your view? Do you think that the ruling would have come out the same way, and/or sounded the same in rhetoric and tone, had a same-sex couple taken great pains to fulfill a dream of becoming parents, with the same basic facts in the background? Should it matter whether parties dream of becoming parents or not, when tabulating and allocating damages? If the opinion can be accused of naturalizing a heteronormative view of the world with fixed notions of gender (e.g. women dream of having babies; it’s tragic if they can’t), should we worry about whether courts will misalign with a world in which gender increasingly needs to be understood as fluid? Should gender roles continue to be allowed to carry the same weight and meanings as they may once have, in light of present understandings of gender? What can tort law do to address such concerns and questions?

The case was upheld on appeal, *Zuchowicz v. U.S.*, 140 F.3d 381, 391-392 (1998). The court made only the briefest mention of her pregnancy: “Mrs. Zuchowicz was on the waiting list for a lung

transplant when she became pregnant. Pregnant women are not eligible for transplants, and pregnancy exacerbates PPH. Mrs. Zuchowicz gave birth to a son on November 21, 1991. She died one month later, on December 31, 1991.” *Id.* at 384.

Chapter 34. Statutory Caps on Damages (Socratic Script)

Many states have passed statutes that create mandatory maximums or “caps” on the damages that victims in civil lawsuits may recover. In several states, the statutes were found unconstitutional (and in a subset of those, the statutes were amended and passed again after being found unconstitutional). The majority (42 states plus the District of Columbia) have no caps in personal injury cases and products liability cases. Only 22 (plus the District of Columbia) have no caps in medical malpractice lawsuits. Statutory caps frequently focus on establishing limits to general (noneconomic) damages although in the medical context some statutes are sometimes drafted more broadly to limit special damages as well. By far the most common limits, however, are generally on compensation for noneconomic damages, which include disfigurement, permanent disability, mutilation, loss of a limb, trauma, sexual or reproductive harm and other types of pain and suffering. Anything that has had or will continue to have a challenging or negative effect on the plaintiff and that was caused by the tortious conduct and not otherwise accounted for in financial terms can count. The next case applies Maryland’s cap on statutory damages for the loss of a beloved family pet and clarifies the issue of whether the statute permits recovery for non-economic damages pursuant to the loss.

Anne Arundel County v. Reeves, Court of Appeals of Maryland (2021) (Only the Westlaw citation is currently available) (2021 WL 2306720)

This case affords us the opportunity to address the scope of compensatory damages available in the case of the tortious injury or death of a pet. Resolution of that issue requires our examination of the text of Md. Code Cts. & Jud. Proc. (“CJP”) § 11-110. The General Assembly enacted CJP § 11-110 to allow pet owners to recover certain capped damages for the death or injury of their pet as a result of a tort. We are asked to determine whether a pet owner may recover other forms of compensatory damages not expressly included within that statute. We must also address the separate question of whether there was sufficient evidence of gross negligence in this case.

These questions stem from Anne Arundel County Police Officer Rodney Price’s fatal shooting of a family dog while carrying out his duties as a police officer. On February 1, 2014, Officer Price encountered Respondent Michael Reeves’ dog, Vern, a Chesapeake Bay retriever, in the front yard of Mr. Reeves’ home. Evidently believing he would be attacked, Officer Price shot Vern twice. The dog died soon thereafter. Mr. Reeves subsequently brought suit alleging, inter alia, that by fatally shooting Vern, Officer Price committed a trespass to Mr. Reeves’ chattel, acted with gross negligence, and violated Mr. Reeves’ rights under Articles 24 and 26 of the Maryland Declaration of Rights.

The case went to trial before a jury in the Circuit Court for Anne Arundel County. The jury returned a verdict in favor of Mr. Reeves, finding that Officer Price committed a trespass to Mr. Reeves’ chattel, acted with gross negligence, and violated Mr. Reeves’ constitutional rights under Articles 24 and 26 of the Maryland Declaration of Rights. The jury awarded no damages for the constitutional violations, \$10,000 for the trespass to chattel claim, and \$500,000 in economic damages and \$750,000 in noneconomic damages for the gross negligence claim. The circuit court then reduced the gross

negligence damages to \$200,000 pursuant to the Local Government Tort Claims Act (“LGTC”). CJP § 5-301 *et seq.* The circuit court also reduced the trespass to chattel damages to \$7,500 pursuant to the then-applicable damages cap in CJP § 11-110.¹⁷⁰

***2** On appeal, the Court of Special Appeals affirmed in part and held in an unreported divided decision that CJP § 11-110 did not bar Mr. Reeves from recovering noneconomic damages related to the death of his dog. The same majority also held that there was legally sufficient evidence to support the jury’s verdict that Officer Price acted with gross negligence.

For reasons that follow we hold that CJP § 11-110 limits the recovery for compensatory damages to the amount specified by that statute and does not allow for recovery of noneconomic compensatory damages stemming from the tortious injury or death of a pet. In addition, we hold that there was legally sufficient evidence to support the jury’s finding that Officer Price was grossly negligent in the fatal shooting of Vern. However, under the single recovery rule, we also hold that Mr. Reeves may not recover any damages under the gross negligence claim. Accordingly, we reverse in part and affirm in part the judgment of the Court of Special Appeals.

On February 1, 2014, as part of an ongoing investigation into a spate of burglaries in a residential neighborhood in Anne Arundel County, Officer Price was going door-to-door seeking relevant information. Officer Price, the only witness to the events that ensued immediately thereafter, would later testify at trial to the following. At approximately 4:45 p.m., Officer Price approached Mr. Reeves’ residence from the house next door. He saw a light on inside and noticed that some of the windows were open. [***] Officer Price determined from those indicators that the house was occupied at the time. He testified that he had no reason to believe that any member of the Reeves family had any involvement with the burglaries and he did not have any “cause for concern” as he approached the house.

Officer Price walked onto the front porch of Mr. Reeves’ home and knocked on the closed door. When no one answered, he left the porch and headed towards Mr. Reeves’ driveway, where he stood with his back to the house. As he was taking notes in his notepad, Officer Price heard the sound of a door behind him. He turned around and saw a dog “coming at” him from about five feet away. According to Officer Price, the dog was growling and barked once.

Officer Price testified that he put his left forearm up at “roughly” the level of his neck as the dog approached. Officer Price stated that the dog placed its front paws on his forearm for about one second. He recalled taking one step back and pushing the dog away from him. Afraid that the dog was going to attack his face, Officer Price testified that he shot the dog twice while the dog’s paws were still on his left arm. The dog then made a screeching noise and limped across the yard, where the dog collapsed. After the shooting, Officer Price informed dispatch of what happened, saying “a dog came at me.” According to Officer Price, the dog did not bite or scratch him during the incident.

Officer Price is 5’8” and, at the time of the incident, weighed about 250 pounds. He testified that he had a taser, baton, and mace on his person at the time. Furthermore, he admitted that he did not vocalize

¹⁷⁰ Since the conduct underlying this case occurred, the Legislature has increased the cap to \$10,000. *See* S. 143, 2017 Leg., 437th Sess. (Md. 2017). Throughout this opinion, we shall refer to the version of the statute in place at the time of the events of this case.

any commands to the dog. At the time of the incident, Officer Price had been a sworn officer for less than a year.

3** Shortly after the shooting Mr. Reeves exited the house, approached Officer Price, and asked him what had happened. [] Mr. Reeves testified that he then stepped forward and Officer Price responded by drawing his firearm. With his hand on the weapon, Officer Price told Mr. Reeves: “Stop. Don’t take another step.”¹⁷¹ Mr. Reeves then turned around and rushed to where his dog Vern had collapsed on the other side of the yard and was curled up beneath the neighbor’s fence. Mr. Reeves proceeded to administer CPR to Vern.

Additional officers arrived at the scene, and Officer Price returned to headquarters. Mr. Reeves testified that he believed that Vern died on the scene, but his son, Michael Reeves Jr., drove Vern to a nearby veterinary hospital where the dog was confirmed dead.¹⁷²

On September 24, 2015, Mr. Reeves and his sons, Michael Jr. and Timothy, filed a complaint asserting thirteen claims against Anne Arundel County (the “County”), Anne Arundel County Police Chief Kevin Davis, and Officer Price. [fn] The claims that ultimately proceeded to trial against the County and Officer Price (“Petitioners”) were: (1) trespass to chattel; (2) violation of Mr. Reeves’ constitutional rights under Article 24 of the Maryland Declaration of Rights for the unlawful shooting of his dog; (3) violation of Mr. Reeves’ constitutional rights under Article 26 of the Maryland Declaration of Rights for the unlawful seizure of the dog; and (4) gross negligence.

Trial in the circuit court began on May 4, 2017. Mr. Reeves’ counsel called Officer Price as an adverse witness. Officer Price had previously stated in a deposition that because the dog’s paws were muddy, paw prints covered his uniform. He had also stated during the deposition that he had dirt on both of his shoulders and on his badge. At trial, counsel for Mr. Reeves introduced photographs that the police department took shortly after the incident. When shown the photographs, one of which was magnified 300 times, Officer Price admitted that there was no mud or dirt from the dog’s paws on his upper body or badge. He further acknowledged that the photographs showed mud on the thigh area of his pants. He also admitted that there were no cuts or scratches on his forearm or tears in his uniform.

Mr. Reeves’ counsel then played a video deposition of the testimony of an out-of-state witness, Dr. Kevin Lahmers, a veterinary pathologist at the Virginia-Maryland College of Veterinary Medicine. [***]

***4** Dr. Lahmers explained that Vern weighed around 75 pounds and, based on images of the dog, if standing on hind legs Vern would only reach the stomach or mid-abdomen of an adult man of average height. Dr. Lahmer’s testimony was thus at odds with Officer Price’s account that Vern could have reached the height of the officer’s neck while the dog’s front paws were on the officer’s forearm.

Mr. Reeves’ son Timothy then took the stand and explained that his father had purchased Vern as a puppy in 2009. According to Timothy, Vern was intelligent, playful, sweet, and a quick learner. He testified that Vern had not displayed aggression towards other pets or people, including children, and

¹⁷¹ Mr. Reeves also testified that Officer Price likewise “put[] his hand on his weapon” on two other occasions when Mr. Reeves’ two sons approached Officer Price.

¹⁷² Michael Reeves Jr. testified at trial that the officers on the scene were blocking his truck for twenty to thirty minutes before he was ultimately able to drive to the veterinary hospital.

Vern had no problems with large crowds in the neighborhood park. Mr. Reeves' other son, Michael Jr., testified that Vern was a member of their family.

After the testimony of his two sons, Mr. Reeves took the stand. He stated that he became interested in training dogs while stationed in Afghanistan.¹⁷³ Mr. Reeves explained that he purchased Vern for \$3,000 with the goal of eventually breeding Chesapeake Bay retrievers. He took a year off from work to train the dog. Mr. Reeves taught Vern voice commands, silent commands, and water training. Mr. Reeves testified that Vern "was my best friend in the world, period." Mr. Reeves also testified that he was taking medication to cope with the loss of Vern. He stated that he no longer had any plans to breed Chesapeake Bay retrievers. Timothy testified that his father moved from Maryland to California after Vern was killed, and that the family "had all left because that incident for my father has just destroyed him."

At the close of trial, the circuit court denied the Petitioners' motion for judgment as to Mr. Reeves' claims under Articles 24 and 26. The court submitted those claims, along with the trespass to chattel and gross negligence claims, to the jury. The circuit court foreclosed the availability of punitive damages, though, by granting the Petitioners' motion for judgment on the issue of actual malice and punitive damages.

After deliberating for approximately one hour and thirty minutes, the jury returned the verdict finding that Petitioners had violated Mr. Reeves' constitutional rights under Articles 24 and 26 of the Maryland Declaration of Rights, Officer Price had acted with gross negligence, and he had committed a trespass to Mr. Reeves' chattel.

The jury found a violation of Mr. Reeves' due process rights under Article 24 by depriving him of his dog. However, the jury awarded him \$0 in damages for that constitutional claim. The jury further found that Officer Price had violated Mr. Reeves' constitutional rights under Article 26 by "seizing" Vern and/or interfering with the use or enjoyment of the dog. The jury likewise awarded Mr. Reeves \$0 in damages for that constitutional claim. As to both constitutional claims, the jury also found that Officer Price did not act with "ill will or improper motivation."¹⁷⁴

***5** The jury then found that Officer Price was grossly negligent and awarded Mr. Reeves \$500,000 in economic damages and \$750,000 in noneconomic damages, for a total of \$1,250,000. Finally, for the trespass to chattel claim, the jury awarded Mr. Reeves \$10,000 in economic damages. The jury also made a factual finding on the verdict sheet that the dog was not attacking Officer Price at the time of the shooting.

On May 18, 2017, Petitioners filed a motion for judgment notwithstanding the verdict, remittitur, and/or a new trial. The circuit court denied the motion in full. The circuit court then reduced the jury

¹⁷³ Mr. Reeves testified that, after serving in the Marines, he had worked as a contractor in the power industry. He testified as to the wages that he earned and the fact that he had not worked since the death of Vern. Per Mr. Reeves' gross negligence claim, he alleged economic damages in the form of lost wages.

¹⁷⁴ This factual finding was relevant to the personal immunity of Officer Price under the LGTCA. Local government employees in Maryland have no immunity if they act with "actual malice," which is defined as "ill will or improper motivation." See LGTCA, CJP § 5-301(b) (" 'Actual malice' means ill will or improper motivation."); CJP § 5-302(b)(2)(i) ("An employee shall be fully liable for all damages awarded in an action in which it is found that the employee acted with actual malice."). Because the jury found that Officer Price did not act with "ill will or improper motivation," the County is liable.

award for trespass to chattel from \$10,000 to \$7,500, pursuant to CJP § 11-110. The court further reduced the total damages award for the gross negligence claim from \$1,250,000 to \$200,000 pursuant to the LGTCA, resulting in Mr. Reeves receiving a total of \$207,500 in damages. Petitioners appealed to the Court of Special Appeals.

The Court of Special Appeals affirmed in part and vacated in part the judgment of the circuit court in a divided unreported opinion. *Reeves v. Davis*, No. 1191, Sept. Term 2018, 2019 WL 5606605 (Oct. 30, 2019). The majority held that CJP § 11-110 did not limit Mr. Reeves' total available damages to the capped amount stated in the statute. The majority reasoned that *Brooks v. Jenkins*, a reported Court of Special Appeals opinion also addressing the fatal shooting of a dog by a police officer, was controlling. *Reeves*, 2019 WL 5606605, at *9; see *Brooks*, 220 Md. App. 444 (2014). The majority explained that:

The County ... asks that we distinguish *Brooks* from this case because the jury did not award Reeves any damages for the County's constitutional violations, whereas the jury in *Brooks* did. However, ... *Brooks* stands for the proposition that CJP § 11-110 does not bar recovery for non-economic damages, at least when the tortfeasor has been grossly negligent.

Reeves, 2019 WL 5606605, at *9. The majority also held that the jury was provided legally sufficient evidence to support its finding that Officer Price had acted with gross negligence. *Id.* at *13.

Judge Friedman dissented, disagreeing with the majority on both issues. He interpreted CJP § 11-110 as limiting all available compensatory damages, including noneconomic damages, to the capped amount provided in the statute when the injury is to a pet. *Id.* at *14 (Friedman, J., dissenting). Given that the jury awarded no damages for the constitutional violations, under the one injury, one recovery rule, the only injury for which Mr. Reeves could recover compensatory damages was the death of his dog Vern, which is capped by the statute. *Id.* at *13–14 (“Calling Mr. Reeves' claims by different names—trespass to chattel, negligence, gross negligence, or even an intentional tort—doesn't change the analysis: there is still just one injury.”) (citation omitted). Judge Friedman also would not have found that there was sufficient evidence to support a finding of gross negligence. *Id.* at *14 n.2.

On appeal to this Court, Petitioners present the following questions for review:

- 1) As a matter of first impression, does [CJP § 11-110] limit the amount of damages recoverable for negligently causing the death of a pet?
- 2) Did the Court of Special Appeals err in finding sufficient evidence of gross negligence?

We affirm the holding of the Court of Special Appeals that there was sufficient evidence to support the jury's finding of gross negligence. However, we reverse on the statutory construction issue and hold that CJP § 11-110 limits the recovery for compensatory damages to the amount specified by the statute and does not allow recovery for noneconomic damages stemming from the tortious injury or death of a pet.

A. Statutory Construction of CJP § 11-110

*6 We are tasked with construing CJP § 11-110 to determine whether, as a matter of first impression before this Court, at the time of the incident the statute limited the recovery of all compensatory

damages to \$7,500 when a pet is tortiously injured or killed. Statutory interpretation is a question of law reviewed *de novo* by this Court. *Brown v. State*, 454 Md. 546, 550 (2017). [***]

We start with the text of CJP § 11-110. At the time of the incident, the statute provided in full:

(a) *Definitions*. — (1) In this section the following words have the meanings indicated.

(2) “Compensatory damages” means:

(i) In the case of the death of a pet, the fair market value of the pet before death and the reasonable and necessary cost of veterinary care; and

(ii) In the case of an injury to a pet, the reasonable and necessary cost of veterinary care.

(3) (i) “Pet” means a domesticated animal.

(ii) “Pet” does not include livestock.

*7 (b) *Measure of damages*. — (1) A person who tortiously causes an injury to or death of a pet while acting individually or through an animal under the person’s direction or control is liable to the owner of the pet for compensatory damages.

(2) The damages awarded under paragraph (1) of this subsection may not exceed \$7,500.

Petitioners contend that CJP § 11-110 applies to all torts, defines the types of compensatory damages a pet owner can recover, and limits those damages to the capped amount. In support of this argument, Petitioners refer to the statute’s structure, which defines compensatory damages in the case of the death or injury of a pet, provides when a pet owner is entitled to those compensatory damages, and caps damages recoverable under the statute.

Mr. Reeves argues that, given the statute’s unique definition of compensatory damages, the damages cap pertains only to reasonable and necessary veterinary care expenses and the pet’s fair market value. Mr. Reeves asserts that nothing in the statute expressly limits the recovery of other possible types of damages, including pain and suffering or lost wages. He notes that the 2005 amendment removed the words “[t]he measure of damages ... is” from the 1999 version and replaced them with “[a] person who tortiously causes an injury to or death of a pet ... is liable to the owner of the pet for compensatory damages,” as defined in the statute. Mr. Reeves argues that this indicates that the Legislature amended the statute in 2005 to allow for the recovery of noneconomic damages.

We disagree with Mr. Reeves’ reading of the statute. The meaning of CJP § 11-110 is plain. CJP § 11-110(b)(1) provides that “[a] person who tortiously causes an injury to or death of a pet while acting individually or through an animal under the person’s direction or control is liable to the owner of the pet for compensatory damages.” Although “tortiously” is not defined in the statute, negligence, gross negligence, and trespass to chattel are torts. As such, the statute applies to cases of gross negligence and trespass to chattel where the injury is to a pet.

“Maryland has long accepted the doctrine of *expressio (or inclusio) unius est exclusio alterius*, or the expression of one thing is the exclusion of another.” *Comptroller v. Blanton*, 390 Md. 528, 537, 890 A.2d 279 (2006). Under the statute, “ ‘Pet’ means a domesticated animal” and “does not include livestock.” CJP § 11-110(a)(3)(i)–(ii). The statute’s definition of “Compensatory damages” in the case of the death of a “Pet” expressly states two things: “the fair market value of the pet before death” and

“the reasonable and necessary cost of veterinary care.” *Id.* § 11-110(a)(2)(i). Additionally, the definition uses the word “means,” indicating that the Legislature intended for the list to be exhaustive. *Id.* § 11-110(a)(2) [***].

The text evinces legislative intent to allow for certain, defined compensatory damages in the case of the tortious death or injury of a pet. Noneconomic damages, such as mental anguish and loss of companionship, are not included in the exhaustive definition of compensatory damages. As such, noneconomic damages are unavailable under the plain meaning of CJP § 11-110. The statute goes on to limit the recovery of damages under the statute to the capped amount. CJP § 11-110(b)(2).

8** We do not read the plain language of CJP § 11-110 in a vacuum. Analogous damages cap provisions in Title 11 of the Courts and Judicial Proceedings Article confirm our understanding of the text’s plain meaning. Maryland’s Wrongful Death Act provides a statutory cause of action for the recovery of certain economic and noneconomic compensatory damages in the case of the wrongful death of a person and strictly limits beneficiaries to spouses, parents, and children. *See* CJP § 3-904. CJP §§ 11-108 and 11-109 define and cap the availability of noneconomic and economic damages in the case of wrongful death or personal injury. The General Assembly has thus expressly provided for the recovery of noneconomic damages when a person has been wrongfully killed. *See* CJP § 11-108(a)(2)(i) (“‘Noneconomic damages’ means: ... In an action for wrongful death, mental anguish, emotional pain and suffering, loss of society, companionship, comfort, protection, care ... or other noneconomic damages authorized under Title 3, Subtitle 9 of this article.”). In contrast, CJP § 11-110 does not expressly provide for similar damages in the case of the wrongful death of a pet. []

In other words, CJP § 11-110’s relationship with other laws in Title 11 of the same Article does not support the anomalous result that legislative silence on the recovery of noneconomic damages for the wrongful death of pets means that they are available when the Legislature has capped recovery of those damages in the case of the wrongful death of people. Mr. Reeves’ reading of the statute would allow, for example, for the recovery of millions of dollars in uncapped noneconomic damages in a case involving veterinary malpractice, while noneconomic damages in a medical malpractice case remain capped. To read CJP § 11-110 in this way would produce absurd results.¹⁷⁵

It would also be illogical for CJP § 11-110 to apply a cap solely on damages related to fair market value and reasonable and necessary veterinary expenses, while allowing pet owners to recover an unlimited amount of other compensatory damages for their emotional loss. Fair market value and veterinary expenses are much more easily susceptible to calculation in monetary terms than are seemingly unlimited damages for emotional pain and suffering. Indeed, in this case the jury awarded Mr. Reeves, in addition to the maximum amount allowable under CJP § 11-110 of \$7,500, noneconomic damages equal to 100 times that amount.¹⁷⁶

¹⁷⁵ One such result would be that a pet owner could recover noneconomic damages for the death of a pet, while that same person could not receive such damages for the loss of a best friend, sibling, fiancé(e), or grandparent. We do not dispute that the Legislature could create such a scheme, but we will not interpret it as doing so through mere silence and in the face of the statute’s plain meaning.

¹⁷⁶ Mr. Reeves argues that recovery of other economic and noneconomic damages under CJP § 11-110 would not be limitless in this case because, at the time of the incident, the LGTCA capped those damages at \$200,000. CJP § 5-303(a)(1) (2013). The LGTCA, however, would not apply in the case of veterinary malpractice, a person’s dog attacking a neighbor’s cat, or numerous other situations covered under the statute where a private individual and not

***9** If the General Assembly’s goal was to cap compensatory damages for pet owners, how strange for it to do so exclusively with respect to such a narrowly defined subset thereof. Doing so would have left all other forms of compensatory damages both uncapped and without guidelines for calculation. Unlike the Wrongful Death Act, the General Assembly did not provide a formula in CJP § 11-110 for quantifying emotional loss in the situation of the wrongful death of a pet. Our reading of CJP § 11-110 in light of the Wrongful Death Act provisions confirms our understanding that such damages are unavailable in the case of the tortious injury to or death of a pet. Certainly, the General Assembly knows how to expressly provide for noneconomic damages when it wants to, as it did with respect to the damages under the Wrongful Death Act.

[***][A]n award for compensatory damages must be anchored to a rational basis on which to ensure that the awards are not merely speculative.” [c]

Punitive damages are designed to accomplish another goal entirely—to punish the wrongdoer for particularly egregious or heinous conduct and to deter others from following suit. [c] When the trial court in this case granted the Petitioners’ motion on the issue of actual malice and punitive damages, it precluded the jury from awarding them to Mr. Reeves.¹⁷⁷ As a result, the only type of damages available to Mr. Reeves for the grossly negligent shooting of his dog and the trespass to his chattel are compensatory damages, which are exhaustively defined and limited by the express terms of CJP § 11-110.¹⁷⁸

10** Additionally, there can be only one recovery of damages for each injury under Maryland law. [cc] *Francis v. Johnson*, 219 Md. App. 531, 561 (2014) (“The Maryland appellate courts have made clear that there can be only one recovery of damages for one wrong or injury.”). We have explained that “[u]nder the Maryland rules, [d]ifferent legal theories for the same recovery, based on the same facts or transaction, do not create separate claims.” *Beall*, 446 Md. at 70 [].

Here, Mr. Reeves’ gross negligence and trespass to chattel claims are premised on the same set of operative facts. They are thus alternative legal theories for the same recovery. Therefore, Mr. Reeves is entitled to one recovery as compensation. Notwithstanding the fact that Mr. Reeves suffered a tragic loss, the only injury before us for which Mr. Reeves can recover is the death of his dog, because the jury awarded no damages for the constitutional harms.

a local government is at fault. CJP § 11-110 does not distinguish between tort claims against local governments and claims against private individuals.

¹⁷⁷ The Dissent states that our reading of CJP § 11-110 would “limit all possible recovery” to a complainant in the case of the “injury or death of a pet.” However, this case does not deal with “all possible recovery” in such cases. Rather, it deals solely with compensatory damages, as distinguished from punitive damages, and as they are defined in the statute. The statute, by its own terms, does not address punitive damages, and they are also not at issue in this case. Also not at issue here is the exception to the common law rule that allows for certain forms of noneconomic damages when property is damaged by a tortfeasor whose acts are “inspired by fraud, malice, or like motives.” [cc] This case clearly does not involve fraud, and the jury expressly found that Officer Price did not act with actual malice, i.e. “ill will or improper motivation.”

¹⁷⁸ CJP § 11-110 was not enacted upon tabula rasa. Rather, it augmented well-established common law principles of recovery in cases of tortious injury to personal property. Under the common law, domestic animals such as pets have been legally classified as personal property. [***] CJP § 11-110 merely codified the existing recovery rule in cases involving pets, allowed for an additional and limited form of damages in the way of defined veterinary expenses, including veterinary expenses that exceed the pet’s fair market value, and capped all available compensatory damages.

[***] The Dissent contends that we have passed on the opportunity to change Maryland’s common law to expand the damages available in the case of the tortious death or injury of a pet, in line with a minority modern trend. However, no such opportunity is before us. The issue in this case is not whether our common law is or should be in line with modern sensibilities regarding pets. Also not before us is the issue of whether Maryland law classifying pets as personal property should be changed. Rather, this case presents the narrow issue of whether CJP § 11-110, which defines all compensatory damages in cases involving the injury to or death of a pet, can also be read to allow for types of damages it leaves out of that exhaustive definition. We conclude that the statute cannot be read in such a manner.

***11** The Legislature may wish to amend CJP § 11-110 in response to the various policy arguments in this case in order to allow for other forms of compensatory damages in cases involving the tortious injury or death of pets.¹⁷⁹ However, under the statute in its current form, such damages are strictly limited to the two forms provided. If the Legislature intended to compensate pet owners for noneconomic damages associated with the tortious death of their pets, it would have stated so plainly in the language of CJP § 11-110.

In sum, the plain meaning of CJP § 11-110 is that it defines what compensatory damages are available in the case of the tortious injury to or death of a pet and limits the total amount that may be recovered. It does not allow for recovery of other forms of compensatory damages not expressly included therein.

[The Court then reviewed the legislative history of CJP § 11-110.]

B. Sufficiency of the Evidence of Gross Negligence

We turn now to whether the jury had sufficient evidence to reach a finding of gross negligence against Officer Price and the circuit court’s denial of the Petitioners’ motion for judgment notwithstanding the verdict. “Issues involving gross negligence are often more troublesome than those involving malice because a fine line exists between allegations of negligence and gross negligence.” [cc] Gross negligence is “something *more* than simple negligence, and likely more akin to reckless conduct.” [c] It is “an intentional failure to perform a manifest duty in reckless disregard of the consequences as affecting the life or property of another, and also implies a thoughtless disregard of the consequences without the exertion of any effort to avoid them.” Additionally, “a wrongdoer is guilty of gross negligence or acts wantonly and willfully only when he inflicts injury intentionally or is so utterly indifferent to the rights of others that he acts as if such rights did not exist.”

13** In *Brooks v. Jenkins*, the Court of Special Appeals held that the trial court did not err by permitting the jury to decide whether the deputy was grossly negligent when he shot the Jenkinse’s family dog. 220 Md. App. at 461–62. [] In *Brooks*, the court noted that there was no evidence the dog was a vicious animal or posed a threat; the video recording from the deputy’s body camera showed the dog’s tail wagging as it approached the deputy, and the dog did not approach the deputy with speed or in a

¹⁷⁹ One such policy argument is that advanced by the Maryland Veterinary Medical Association, the American Kennel Club, the Cat Fanciers’ Association, the Animal Health Institute, the American Veterinary Medical Association, the National Animal Interest Alliance, the American Pet Products Association, the American Animal Hospital Association, and the Pet Industry Joint Advisory Council, who submitted an *amici curiae* brief with this Court. Therein, they stated that if awards of noneconomic damages are permitted for negligence, the cost of veterinary care, pet food and other products, and other pet services would increase to accommodate the new liability, and pet owners might not be able to afford these necessary products and services. Such policy considerations are the proper province of the Legislature.

crouched position; and the video recording showed the deputy point his gun directly at the dog’s chest and shoot, rather than use lesser force. [c] court stated that “the evidence sufficed to support the jury’s finding that the Deputy overreacted to the potential threat, responded with excessive force, and acted with reckless indifference, and the court was correct to allow the jury to make that decision.”

Here, the jury was presented with more than evidence of “simple negligence.” When “viewing the evidence and the reasonable inferences to be drawn from it in the light most favorable to the non-moving party,” there was sufficient evidence for a juror to have drawn the rational inference that Officer Price acted with utter indifference towards Mr. Reeves’ rights when Officer Price shot his dog twice. [***]

Accordingly, viewing the facts in the light most favorable to Mr. Reeves, we agree with the Court of Special Appeals that Mr. Reeves presented sufficient evidence at trial for a rational juror to find that Officer Price was grossly negligent. Thus, we uphold the circuit court’s denial of the Petitioners’ motion for judgment notwithstanding the verdict. However, despite the fact that there was sufficient evidence on the gross negligence claim, as explained above Mr. Reeves’ damages are limited to \$7,500 for his claims, as both the trespass to chattel claim and the gross negligence claim sought recovery for the same harm and both are torts covered by CJP § 11-110. Thus, consistent with the jury’s award and the circuit court’s reduction of the award, Mr. Reeves is limited to \$7,500 on his trespass to chattel claim, and \$0 on his alternative gross negligence claim.

***14** In light of CJP § 11-110’s plain language and structure, its relationship with the Wrongful Death Act, and its legislative history, we conclude that the statute defines and caps the recovery of compensatory damages in the case of the tortious death or injury of a pet. Construing CJP § 11-110 to allow recovery for additional undefined and uncapped compensatory damages, including lost wages and mental anguish, would produce illogical results. Accordingly, we reverse the judgment of the Court of Special Appeals on the statutory construction issue.

Further, we affirm the judgment of the Court of Special Appeals on the gross negligence issue. There was sufficient evidence at trial for the jury to [***] have found that Officer Price acted willfully or with utter indifference towards Mr. Reeves’ rights, and thus, was grossly negligent. However, pursuant to the single recovery rule and CJP § 11-110, we reduce the total damages award to \$7,500, consistent with the statutory cap at the time that this cause of action arose.

Hotten, J., dissenting

For while we have our eyes on the future[,]
history has its eyes on us[.]
This is the era of just redemption[.]
We feared at its inception[.]
We did not feel prepared to be the heirs
of such a terrifying hour
but within it we found the power
to author a new chapter[.]¹⁸⁰

¹⁸⁰ Amanda Gorman, The Hill We Climb, The Hill, <https://thehill.com/homenews/news/535052-read-transcript-of-amanda-gormans-inaugural-poem> (Jan. 21, 2021), archived at <https://perma.cc/YR5V-WGZX>.

Respectfully, I dissent. The Majority interpreted Md. Code Ann., Courts and Judicial Proceedings (“Cts. & Jud. Proc.”) § 11-110 to preclude the recovery of noneconomic damages for a pet dog killed as a result of gross negligence. The Majority need not have reached its conclusion under a narrow construction of the statute and Maryland common law. Assuming *arguendo* that our controlling authority mandated the result found in the Majority opinion, the ineffable societal value ascribed to pets warrants a reassessment of Maryland law that continues to treat cherished family pets as mere chattel.

***15** The Majority affirmed in part the Court of Special Appeals’ holding that Officer Price acted with gross negligence when he shot and killed Vern, but the Majority reversed in part the Court’s holding that Cts. & Jud. Proc. § 11-110 permits recovery of emotional damages that arise from grossly negligent harm to pets. The Majority reads the statute’s \$10,000 compensatory damage cap to limit *all possible* recovery for an injury or death of a pet.

The Majority did not have to reach this conclusion and should have concluded that pets killed or injured with gross negligence may permit the recovery of emotional damages. We are bound to interpret statutes that displace common law as narrowly as possible. [***] To date, Maryland common law has not clearly specified whether gross negligence is equivalent to “fraud, malice, or like motives” especially in the context of tortious harm to pets. This Court has noted that there is not a consistent usage of gross negligence across “more than twenty-five appearances in our statutes[.]” *Taylor*, 384 Md. at 227.¹⁸¹ This Court in some instances equated gross negligence with “fraud, malice, or like motives” in the past,¹⁸² which according to longstanding precepts of Maryland common law may render a tortfeasor liable for emotional damages for damage to property. *Aronoff*, 197 Md. at 539. It would have been sound, especially given the strong emotional bond between people and pets, for the Majority to recognize an additional exception to the common law that grossly negligent harm to pets may entail liability for emotional damages. Pets, particularly dogs, possess individual personalities, emotions, intelligences, and behaviors.¹⁸³ Maryland law should distinguish between the recovery of grossly negligent harms to pets and inanimate objects accordingly.

***16** Pets already hold an anomalous position within Maryland law. They are the only type of “property” with capped *compensatory* damages. The Majority’s decision places pets in a doubly anomalous position: they are the only type of property subject to a compensatory and non-compensatory cap. A

¹⁸¹ See, e.g., Md. Code Ann., Insurance § 5-201(j) (“Except for fraud, willful misconduct, or gross negligence, a qualified actuary is not liable for damages ...”); Md. Code Ann., Business, Occupations & Professions § 3-311(a)(1)(iii) (revoking an architecture license if applicant or licensee “is guilty of any fraud, gross negligence, incompetence, or misconduct...”); Md. Code Ann., Natural Resources § 8-716.1(f)(1) (waiving statute of limitations for personal tax debt if “proof of fraud or gross negligence...”).

¹⁸² *Cooper v. Rodriguez*, 443 Md. 680, 710, 118 A.3d 829, 846 (2015) (holding corrections officer acted with gross negligence to lose immunity under Maryland Tort Claims Act); *Booth v. Robinson*, 55 Md. 419 (1881) (holding directors of a corporation breach their fiduciary duty through gross negligence in the same way directors would be for fraud); see also *Ford v. Balt. City Sheriff’s Office*, 149 Md. App. 107, 120-21, 814 A.2d 127, 134 (2002) (if “the State employee has acted with *malice or gross negligence*, . . . the State is immune from suit and the injured party may only bring a viable tort claim against the State employee.”) (emphasis added); but see *Ellerin v. Fairfax Sav., F.S.B.*, 337 Md. 216, 228, 652 A.2d 1117, 1123 (1995) (precluding gross negligence as a basis for punitive damages in non-intentional tort cases).

¹⁸³ News and social media are replete with stories that reinforce common experience and understanding of pets as cherished companions. See, e.g., *The Dodo*, <http://www.thedodo.com> (last visited May 25, 2021), archived at <https://perma.cc/V52M-TRHK>.

tortfeasor may “wantonly and willfully” shoot and kill a beloved, family dog, “utterly indifferent” to the family’s emotional bond and pay no more than \$10,000 in damages, while a fraudster who intentionally tricks a family into selling a painting of their dog would face uncapped compensatory damages and punitive damages.

The Majority’s decision also creates an incongruous result where a person can be *criminally liable* for neglecting their pet under Maryland’s animal cruelty law, Md. Code Ann., Criminal Law § 10-601(c)(1) (“ ‘Cruelty’ means the unnecessary or unjustifiable physical pain or suffering caused or allowed by an act, omission, or neglect[]”), but if *someone else kills* one’s pet with gross negligence, they will only face a maximum compensatory damage penalty of \$10,000.

The Majority’s decision stands at odds with the modern trend of our sister jurisdictions that have recognized a greater right of recovery for injured or killed pets. More than fifty years ago, the Florida Supreme Court held in *La Porte v. Associated Independents, Inc.* that “the malicious destruction of the pet provides an element of damage for which the owner should recover, irrespective of the value of the animal[.]” 163 So. 2d 267, 269 (Fla. 1964). The plaintiff saw a garbage collector throw a trash can at her dog, Heidi. The garbage collector laughed and drove away. Heidi died from the impact. The trial court limited the plaintiff’s recovery to the fair market value of the dog. The Florida Supreme Court reversed recognizing the “very real” affection between a person and their pet.

Similar decisions have since been reached in Alaska, California, Florida, Hawaii, Idaho, Kentucky, Puerto Rico and Washington. [cc] In *Plotnik v. Meihaus*, 208 Cal. App. 4th 1590 (4th Dist. 2012), the plaintiffs sued their neighbor after he allegedly struck their 12-inch tall miniature pinscher with a baseball bat after the dog dashed into the neighbor’s yard. *Id.* at 1605, 146 Cal. Rptr.3d at 598. The California Court of Appeal for the Fourth District held:

We believe good cause exists to allow the recovery of damages for emotional distress under the circumstances of this case [W]hile it has been said that [dogs] have nearly always been held to be entitled to less regard and protection than more harmless domestic animals, it is equally true that there are no other domestic animals to which the owner or his family can become more strongly attached, or the loss of which will be more keenly felt. Additionally, one can be held liable for punitive damages if he or she willfully or through gross negligence wrongfully injures an animal.

Id. at 1607, 146 Cal. Rptr. 3d at 600 (internal citations and quotation omitted).

The court based its decision on California’s civil code that permits recovery of exemplary damages or “damages for the sake of example and by way of punishing the defendant[]” for malicious, oppressive, or fraudulent conduct. Cal. Civ. Code § 3294 (1992). These conditions for granting relief to an injured pet in California closely parallel Maryland’s common law basis of recovering emotional damages for property in Maryland. *See Zeigler*, 248 Md. at 226 (allowing recovery of emotional damages for harms to real property “inspired by fraud, malice, or like motives[]”). By permitting the recovery of emotional damages for injuries or death sustained by pets, as a result of grossly negligent conduct, we would have joined a modern trend among sister jurisdictions that recognize the close emotional bond humans share with their pets. [***]

Marylanders have strong emotional bonds with their pets, especially their dogs. Most people, including Mr. Reeves, considered his dog a part of the family and “his best friend in the world[.]” The designation

of dogs as mere personal property belies common experience, cultural values, and societal expectations. Treating dogs as mere property also erases a dog's intrinsic attributes as a living being and the irreplaceable instinct to love and protect human companions. A dog, unlike an inanimate object, welcomes its human companion after a day at work, protects its human companion when in danger, and exhibits behavior and emotions that is consistent with grief and distress when its human companion is ill, injured, or passes away. Given prevailing societal values, attitudes, and norms, it no longer appears tenable to deny emotional damages for a cherished family dog, killed with gross negligence, in the same way that the common law precludes emotional damages for an inanimate object that was accidentally broken. [c]

Marylanders can no longer rely on *Brooks* to vindicate the loss of a cherished pet companion. The Majority's decision comes at a time when pet ownership is surging. The 2019-2020 National Pet Owners Survey estimated 67% of U.S. households have a pet, up from 56% in 1988. This data omits the recent uptick following the Covid-19 global pandemic. Kim Kavin, *Dog Adoptions and Sales Soar During the Pandemic*, The Washington Post (Aug. 12, 2020). Pet adoption has always provided more than just companionship, it establishes a connection and unconditional love. KK Ottesen, *Humane Society President Discusses the Surge of Pet Ownership During the Pandemic – And What Animals Can Teach Us*, The Washington Post (Apr. 27, 2021) (“[Animals] provide [connection and unconditional love]. That’s who they are. That’s what they do.”).

The Majority has missed an opportunity to recognize pets, not just as emotive, intelligent, loving, and cherished members of our families, but as representing more than mere personal property. In the past, courts did not wait for legislative enactment to expand the concept of personage when societal needs, values, and interests demanded it. This Court can break from precedent when “passage of time and evolving events” render it “archaic or inapplicable to modern society[.]” *State v. Stachowski*, 440 Md. 504, 520 (2014). Greater legal protection of beloved family pets is long overdue.¹⁸⁴

19** The average Marylander may be surprised to hear that while the law treats a caring, loyal, and vivacious pet dog as personal property, it treats a corporation as a person. Common law has recognized corporate personhood for centuries. []

The average Marylander may be more surprised to hear that the law has recognized a *boat*, or more precisely, a vessel, as a legal person. *Ralli v. Troop*, 157 U.S. 386, 403 (1895) (affirming “a distinct principle of the maritime law, namely, that *the vessel*, in whosoever hands she lawfully is, *is herself*

¹⁸⁴ The perpetuation of Maryland common law's categorization of pets as personal property, despite prevailing societal sentiment, calls to mind a vigorous dissent from Judge Starcher of the West Virginia Supreme Court: This opinion is simply medieval. The majority blithely says that “our law categorizes dogs as personal property”—that “damages for sentimental value, mental suffering, and emotional distress are not recoverable” when one's pet is injured or killed by the negligence of another person. In coming to this conclusion, the majority overlooks the fact that the “law” in question is the common law which is controlled by this Court. There was nothing stopping the majority from changing that common law other than their lack of concern for pet owners and the emotional bonds that exist between owners and their pets. When the common law of the past is no longer in harmony with the institutions or societal conditions of the present, this Court is constitutionally empowered to adjust the common law to current needs. ... As Justice Holmes succinctly reflected, “[t]he common law is not a brooding omnipresence in the sky but the articulate voice of some sovereign or quas sovereign that can be identified.” ... Yet the majority opinion continues to maintain the primitive limits of the common law, and refuses to adjust to the realities of the modern world, and permit recovery of damages for sentimental values, mental suffering, or emotional distress. *Carbasha v. Musulin*, 217 W. Va. 359, 363, 618 S.E.2d 368, 372 (2005) (Starcher, J., dissenting).

considered the wrongdoer, liable for the tort, and subject to a maritime lien for the damages”) (emphasis added). Even though vessels constitute inanimate amalgamations of mostly steel, aluminum, fiberglass and timber, the law endows the vessel with a legal personality (usually gendered as female) and empowers “her” recovery for tort damages.

The common law extended recognition of legal personage to what the average person would consider property not because people loved corporations and vessels more than their pets. Instead, legal, commercial, and societal interests demanded it. “[A]nything can be made a legal unit, and the subject of rights and duties, a fund, a building, a child unborn, a family. There is no reason, except the practical one, why, as someone has suggested, the law should not accord to the last rose of summer a legal right not to be plucked.” [c]

Similarly, extending legal personhood to pets on a limited basis to recover for emotional damages for the pet’s grossly negligent injury or death could present an incremental change to Maryland tort law. More importantly, it serves to dignify the deep emotional connection between humans and their pets and underscores a widely shared belief in modern society that animals are not chattel, but members of the family.¹⁸⁵

The law should similarly extend a recognition of limited personhood to pets, if only so their human companions can seek recovery for grossly negligent conduct that caused injury or death to that pet. The law should reflect the importance and centrality of pets to individual families and society as a whole. It has already done so for multinational corporations and vessels. Pets deserve similar treatment.

***20** The designation of pets under the common law as mere personal property deprives pets the dignity of living beings. When Maryland became a state in 1788, it formally inherited the common law of England, which still considered slaves, women, and pets as property. Over decades of struggle and progress, Maryland, like every state in the union, cast aside the harmful classification of people as property.¹⁸⁶ Pets should not be consigned to eighteenth-century notions of property. It denies the

¹⁸⁵ The law already allows a mother, who sustains personal injury, and as a result of the negligent conduct of another, suffers the loss of a fetus, to recover emotional damages for the death of an unborn child. *Smith v. Borello*, 370 Md. 227, 247 (2002) (holding that a mother may recover demonstrable emotional distress that accompanies and is attributable to the loss of the fetus and the distress recoverable includes that arising from the unexpected termination of her pregnancy and the enduring of a miscarriage or stillbirth).

¹⁸⁶ History has taken a dim view on legal decisions that perpetuated the treatment of people as property merely because the law previously prescribed it. The United States Supreme Court infamously held in *Dred Scott v. Sandford*, “[b]ut it is too clear for dispute, that the enslaved African race were not intended to be included, and formed no part of the people who framed and adopted this declaration[.]” 60 U.S. 393, 410 (1857). The *Dred Scott* decision has been widely condemned and regarded as one of the most repudiated decisions by the United States Supreme Court. [***] This Court made the same mistake as the United States Supreme Court when it decided *Hughes v. Jackson*, 12 Md. 450 (1858) (recognizing Maryland’s common law treatment of slaves as property, devoid of civil rights, including the right to sue or be sued). While different in kind and degree, courts propagated the doctrine of coverture, which treated married women as quasi property of the husband. *R. & E. Builders, Inc. v. Chandler*, 144 Vt. 302, 304 (1984) (describing “common law legal fiction that a husband and wife are one person for most legal purposes[.]”). Notably, “a wife could not sue anyone for a tort committed against her without her husband’s consent; neither could she be sued for committing a tort without having her husband joined as a defendant.” *Id.* at 304. Courts only gradually removed de jure subjugation of women from the common law in the twentieth century. *Trammel v. United States*, 445 U.S. 40 (1980) (“Chip by chip, ... cast aside so that [n]o longer is the female destined solely for the home and the rearing of the family, and only the male for the marketplace and the world of ideas[.]”).

dignity abundantly ascribed to pets by society. It prevents people of Maryland from being made whole after a tragic injury or death of their pet.

The legal arc of Maryland is one of progress and bends inexorably towards greater recognition of rights. The common law designation of pets as personal property, rooted in legal formalism, conflicts with society's values and the trajectory of common law in Maryland and throughout the country. Our pets are more than just living beings. They are widely considered best friends, guardians, and members of the family. Maryland law should recognize and bestow pets with the same degree of dignity.

In this instance, it appears that pet owners who sustain the loss of the pet as the result of the grossly negligent acts of another will have no recourse other than with the General Assembly to move Maryland forward.

For these reasons, I dissent and would affirm the judgment of the Court of Special Appeals.

Note 1. What evidence did the plaintiff offer for why he was seeking noneconomic damages? If you were a juror, what would you have thought of that claim? Which elements struck you as more or less persuasive?

Note 2. How did the statute define the pet's value? Considering that in light of how the plaintiff described his attachment, does it seem that certain sorts of things the law tries to value are incommensurate? That is, does the law's system of valuation fail to align with how individuals experience their lives (and losses)? Is the cap on damages an injustice that fails to account for that incommensurability, if so, or might it be a response to it?

Note 3. The dissent argues for an extension of limited personhood to pets and it offers multiple arguments in support of its argument. One of these is dignitarian in nature (designating pets as personal property "deprives pets of the dignity of living beings," p. *20). It points to 18th-century common law under which people of color were enslaved and treated as property. Courts have sometimes suppressed ugly aspects of our national history, including the extent to which the country profited from the labor of enslaved persons. Hence not shying from it seems healthy, in many cases. Is the analogy apt here, however well intended? Or could elevating the interests of animals in this way seem like an affront to those who were enslaved? Is creating an equivalence between groups of living beings (women, people of color and dogs) simply part of a pragmatic strategy to expand the rights of all these groups or could it be read as a subtle devaluation of the autonomy of the human groups relative to animals, a lingering marker of a system of law built on white male supremacy? Is your assessment of this personhood argument affected at all by knowing that the author of the dissent, Judge Michele D. Hotten, is an African-American woman who grew up poor, raised by a single mother in southeast Washington, and went on to become only the second African American woman appointed to the state's highest court? See https://www.washingtonpost.com/local/md-politics/michele-hotten-is-officially-sworn-in-to-serve-on-marylands-highest-court/2015/12/22/9a9fab62-a8b4-11e5-bff5-905b92f5f94b_story.html. As students and scholars, should we be considering the background experiences and identities of the judiciary and the profession at large when interpreting their reasoning? What mistakes can flow from doing so, and what might be missed when not doing so?

Expand On Your Understanding – Socratic Script: Anne Arundel County v. Reeves

Question 1. What was the ruling of the trial court, including kind and amount of damages awarded?

An interactive H5P element has been excluded from this version of the text. You can view it online here: <https://saidtorts2d.lawbooks.cali.org/?p=97#h5p-119>

Question 2. What were the subsequent rulings on appeal? What is the court's holding here?

An interactive H5P element has been excluded from this version of the text. You can view it online here: <https://saidtorts2d.lawbooks.cali.org/?p=97#h5p-120>

Question 3. What was the purpose of the statute at issue in this case?

An interactive H5P element has been excluded from this version of the text. You can view it online here: <https://saidtorts2d.lawbooks.cali.org/?p=97#h5p-121>

Question 4. What conflicting facts arose in the accounts of Price's encounter with Vern? What was their legal significance? What sorts of evidence was used to persuade the jury as to these conflicting facts?

An interactive H5P element has been excluded from this version of the text. You can view it online here: <https://saidtorts2d.lawbooks.cali.org/?p=97#h5p-122>

Question 5. What kinds of arguments did the majority offer in ruling against the availability of noneconomic damages in cases of tortious injury to pets?

An interactive H5P element has been excluded from this version of the text. You can view it online here: <https://saidtorts2d.lawbooks.cali.org/?p=97#h5p-123>

Question 6. The dissent begins with an excerpt of Amanda Gorman's stirring inaugural poem. Why? What is the overarching theory of the dissent's position? What sort of argument is it, in terms of the theories of tort law?

An interactive H5P element has been excluded from this version of the text. You can view it online here: <https://saidtorts2d.lawbooks.cali.org/?p=97#h5p-124>

Question 7. As a descriptive matter, the dissent offers at least five legal arguments to support its position. Whether or not you agree with the dissent, what are a few of those arguments?

An interactive H5P element has been excluded from this version of the text. You can view it online here: <https://saidtorts2d.lawbooks.cali.org/?p=97#h5p-125>

Chapter 35. Implications for Social Justice

In many jurisdictions, courts may still use race, gender and other attributes to determine how much to award for a lost life, or loss of earning potential. On the one hand, in a capitalist society in which people do earn different salaries and do have different professional trajectories, tort law's position is facially defensible. On the other hand, it entrenches the advantages of some over the disadvantages of many. Moreover, it signals that the inequities built into the system are worth continuing to protect and double-down on. *See e.g. Kim Soffen, In One Corner of the Law, Minorities and Women Are Often Valued Less*, Wash. Post; Wonkblog (Oct. 25, 2016),

<https://www.washingtonpost.com/graphics/business/wonk/settlements/>

In many cases, the fact pattern may feel especially unfair intuitively, as when someone's injury seems already to be linked in some way to their racial or socioeconomic status. When the law awards a comparatively small recovery, it conveys, with the cloak of judicial authority, that some injuries matter less and some lives are less valuable than others. The next case takes up these questions in earnest, with tragic and triggering facts.

Let me underscore that the next case features graphic details of a pregnant woman dying in a medical malpractice case. Because at least some of the details of her unnecessarily painful death are relevant to the nature and size of her damages, they are not edited out.

Clemons v. U.S., United States District Court, S.D. Mississippi, (2012) (Not Reported in F. Supp.2d)(2012 WL 5364737)

*1 On May 1 and 2, 2012, the Court held a bench trial in this medical malpractice case. Counsel for the plaintiff and counsel for the defendant announced ready, proceeded to trial, presented evidence, and finally rested. Having considered the evidence and applicable law, the Court now issues its findings of fact and conclusions of law.

Before proceeding, a preliminary statement is in order.

This case is about the tragic and senseless deaths of Tiara Renea Clemons and Aubrey Anna Clemons. They died because an emergency room doctor refused to provide them basic treatment.

The evidence revealed three especially terrible facts. First, the doctor's malpractice caused Tiara Clemons to suffer tremendously before her death. Second, the doctor's malpractice caused the death of Tiara's unborn child, Aubrey Anna, who at 30 weeks along was only a few weeks shy of birth. Third, the deaths of Tiara and Aubrey Anna were completely and utterly preventable. They would be alive today, but for the doctor's refusal to treat them. A more profound case of willful disregard can hardly be imagined.

The United States government indirectly employed the doctor in question. Acknowledging that there was no excuse for the doctor's incompetence, the government admitted liability. The sole dispute at trial was over the amount of damages recoverable by plaintiff Kathy Clemons, who is Tiara's mother,

Aubrey Anna’s grandmother, and guardian to Tiara’s two surviving children. That issue is resolved below.¹⁸⁷

1. Stipulated Facts

The following facts were stipulated by the parties in the Pretrial Order and are therefore accepted by the Court as true. Docket No. 56. The footnotes in this section help explain the stipulations but are not themselves stipulations.

1. On June 27, 2009, Tiara Clemons was a 20 year old Native American female, and a citizen of the Choctaw Nation, residing in Choctaw, Neshoba County, Mississippi. On June 27, 2009, Tiara received a puncture wound near the top of her right scapula. At that time, Tiara Clemons was 30 weeks pregnant with Aubrey Clemons, a minor child. As a result of the wound, Tiara Clemons sought medical treatment for herself and her unborn child from the Choctaw Health Center located in Choctaw, Neshoba County, Mississippi.

2. At approximately 5:19 p.m., on June 27, 2009, Tiara Clemons was examined by Choctaw ambulance EMTs who responded to her call for assistance due to injuries received from a puncture wound to her back. She was examined, and her vital signs were stable. She was noted to be awake and alert, and sitting on the ground. Importantly, the Choctaw EMT noted that she had “bilateral breath sounds clear to auscultation.” Her wound was bandaged, and she was not bleeding externally. Tiara Clemons was given oxygen, and an IV was started on her left hand. In that condition, Tiara Clemons and her unborn child, Aubrey Anna Clemons, were transported to Choctaw Health Center, recognized by the Mississippi Department of Health as a Level IV Trauma Center. *2

3. Tiara and Aubrey Anna arrived at the Choctaw Health Center by ambulance at 5:22 p.m. (Testimony showed that the trip took no more than two minutes. Trial Transcript 89–91 [*hereinafter* “Tr.”]). The Clemons family lived less than a mile from the Choctaw Health Center. *Id.*) They were not seen, examined, or triaged until 5:42 p.m.

4. At 5:42 p.m., Jill Shaw, a family nurse practitioner, examined Tiara. Nurse Shaw noted that Tiara was 30 weeks pregnant with Aubrey Anna, and recorded Tiara’s pain at a “10” on a scale of 1 to 10, with 10 being the “most severe” pain. Nurse Shaw ordered laboratory tests on Tiara’s blood, a chest x-ray, and that a fetal monitor be placed on Tiara to monitor Aubrey Anna. At 5:42 p.m., Nurse Shaw obtained a blood pressure of 109/62.

5. At 5:45 p.m., Tiara and Aubrey Anna were examined by Dr. [Victoria] Guevarra, the ER doctor staffing the Choctaw Health Center Emergency Room. Dr. Guevarra noted that Tiara had received a stab wound in the right scapula, and that by 5:45 p.m., she had decreased breath sounds on the right upper fields. Dr. Guevarra ordered laboratory tests, and ordered that Tiara be given morphine for pain.

6. At 5:53 p.m., Tiara was taken to the radiology room very near the emergency room, where two chest x-rays were taken. The first x-ray was placed in the developer at 5:53 p.m.—the second at 5:57 p.m.

¹⁸⁷ The deaths generated two lawsuits, which have been consolidated. The first suit was filed by Kathy Clemons, as guardian of the minor children, Elona and Keontray Clemons, and on behalf of the wrongful death beneficiaries of Tiara Clemons (the mother of Elona and Keontray). The second suit was filed by Kathy Clemons, as guardian of the minor children, Elona and Keontray Clemons, and on behalf of the wrongful death beneficiaries of Aubrey Anna Clemons (the sister of Elona and Keontray).

These x-rays were available to be viewed by Dr. Guevarra in the emergency room no later than 6:00 p.m. By 6:10 p.m. Dr. Guevarra had reviewed the x-rays and was aware of the internal bleeding.

7. The 5:53 p.m. and 5:57 p.m. chest x-rays revealed that Tiara had a large right pleural effusion, with unilateral pulmonary infiltrate in the right lung, a hemothorax on the right with a fifteen to twenty percent pneumothorax on the right. Upon viewing the x-ray, Dr. Guevarra diagnosed Tiara with a pneumothorax in her right lung, and that she was bleeding internally.

8. At 6:21 p.m., Dr. Guevarra received the result of the blood tests previously ordered. The results showed diminished hemoglobin and hematocrit levels. By 6:40 p.m.¹⁸⁸ Tiara had become hypotensive. Her blood pressure was recorded at 81/47.¹⁸⁹

9. Between 6:50 p.m. and 7:05 p.m. Dr. Guevarra attempted to arrange a transfer of Tiara to Anderson Medical Center in Meridian, Mississippi, by ground ambulance. Dr. Guevarra called Anderson Regional Medical Center in Meridian, Mississippi, located about 40 miles distance, about a transfer. However, the ER doctor at Anderson denied Dr. Guevarra's request for transfer because Clemons was pregnant. Dr. Guevarra did not tell the doctor at Anderson that it was a life threatening situation regarding Clemons.¹⁹⁰ She did not contact or try to transport Clemons to Neshoba County General Hospital, about 8 miles distance.

10. It was at least 6:50 p.m. [***] when Dr. Guevarra began trying to have Clemons transported to [a] medical facility with emergency services. Dr. Guevarra only began this process after being urged by CHC nursing personnel and Choctaw EMS personnel to have Clemons transported to a hospital.

11. Todd Harrison, one of the Choctaw EMT/paramedics, told Dr. Guevarra that Tiara was not stable enough to transport by ground ambulance, and told her to call the AirCare dispatch and send a helicopter to transport Tiara to University Medical Center ["UMC"] in Jackson, Mississippi, a Level I Trauma Center. Dr. Guevarra then called for the UMC AirCare helicopter to transport Tiara. When contacted, UMC immediately dispatched a helicopter with EMT personnel.¹⁹¹ Dr. Guevarra did not relay that CHC had no blood nor ability to drain fluids from Clemons' chest. *3

12. At approximately 7:00 p.m., Dr. Guevarra ordered another chest x-ray, which revealed a "massive" right hemothorax.

13. At 7:30 p.m., Tiara Clemons was assessed by the UMC AirCare EMTs upon their arrival at the Choctaw Health Center. Upon assessment, Tiara was hypoxic, hypotensive, and worsening. Her blood pressure had fallen to 82/54, her oxygen saturation was at 86%, ... and her respirations were 36.¹⁹² The UMC EMTs noted the massive hemothorax visualized on the chest x-ray. Tiara was gasping for breath, and no breath sounds could be heard on the right side of her chest. The UMC EMTs requested that Dr. Guevarra perform a thoracostomy. EMT medical notes reflect that Dr. Guevarra repeatedly refused to

¹⁸⁸ This was approximately one hour and twenty minutes after Tiara arrived in the emergency room, and it was thirty minutes after internal bleeding was confirmed.

¹⁸⁹ This blood pressure reading was obviously lower than that recorded when she arrived.

¹⁹⁰ No explanation for Dr. Guevarra's failure was provided at trial.

¹⁹¹ Evidence shows that UMC AirCare was called and dispatched at 6:47 p.m. PX-37, at 3. The UMC EMTs arrived on the scene at 7:23 p.m. *Id.*; see Tr. 114.

¹⁹² Testimony indicated that Tiara was "breathing twice as fast as she normally should be." Tr. 53.

perform the thoracostomy, a procedure which involves inserting a tube into Clemons' chest to drain the blood, despite requests by UMC EMT.¹⁹³ The UMC EMTs also requested that Dr. Guevarra give blood to Tiara Clemons. Dr. Guevarra did not order blood to be given, and informed that none was available at the Choctaw Health Center.

14. At approximately 7:30 p.m., the UMC EMTs noted that there was a failure to protect Tiara's airway, and intubated Tiara at 7:35 p.m. At 7:45 p.m., due to observed cyanosis (turning blue), decreased breath sounds, severe shortness of breath, decreased cardiac output, low oxygen and oxygen saturation rates, the UMC EMTs performed a needle thoracostomy on the right chest, which returned approximately 300 ml of air and blood.¹⁹⁴

15. At 8:09 p.m., the UMC AirCare EMTs departed for UMC in the helicopter with Tiara and Aubrey Anna. Measured at 8:15 p.m. and 8:30 p.m., Tiara's oxygen saturation level was 42%. By 8:40 p.m., Tiara's oxygen saturation level had dropped so low that it was incapable of measurement, and was recorded as "0%".

16. At 8:42 p.m., as the AirCare helicopter was approaching UMC, while over the VA Hospital [The Court will note that the VA Hospital is next door to UMC], Tiara went into cardiac arrest. At 8:44 p.m., Advanced Cardiac Life Support protocols were employed by the EMTs, including administration of atropine and epinephrine. From 8:44 p.m. until 8:54 p.m. cardiopulmonary resuscitation (CPR) was performed. At 8:45 p.m., the UMC EMTs performed a needle thoracostomy to Tiara's left chest, which returned 20 ml of air and blood. At 8:50 p.m., the UMC EMTs delivered Tiara to the UMC emergency physicians.

17. At 8:50 p.m., the UMC emergency physicians performed a thoracostomy and inserted bilateral chest tubes. The chest tube on the right returned 2400–2500 cc's of blood.¹⁹⁵ A cardiac ultrasound was performed, which revealed no cardiac activity present in either Tiara or Aubrey Anna.

¹⁹³ One UMC EMT testified that Dr. Guevarra "said she did not feel comfortable doing [the chest tube insertion], that she was a family doctor and that she was not going to do it." Tr. 120. This exchange followed: Q [by counsel for plaintiff]. So is it fair to say at 7:30 p.m. you warned Dr. Guevarra ... if she didn't put that chest tube in both Tiara and the baby were going to die? A [by UMC EMT]. Yes. Q. In response to that warning did she take any other action? A. No. Q. What did she do, if anything? A. Honestly she left the room. Q. Did she come back? A. I did not see her after that. Q. So after the warning she basically left you and Mr. King to treat Tiara and Aubrey Anna? A. Yes. Q. And no other physician came? A. I did not see any. *Id.* at 121. The UMC EMTs even offered to show Dr. Guevarra how to insert a chest tube "and basically coach her through the process," since they had seen the simple procedure done many times, but were rebuffed. *Id.* at 127, 136–37, 148–49. (The EMTs were not authorized to perform the procedure themselves. *Id.* at 69–70, 138.) In her deposition, Dr. Guevarra confirmed that she declined to insert a chest tube. PX–49 at 142–44. Plaintiff's expert Dr. Stodard testified that physicians at a Level IV trauma center should "absolutely" have been able to insert a chest tube, as that was an "essential" procedure. *Id.* at 35. "[I]f you can't do that you should not have trauma patients coming to your door." *Id.*; see also *id.* at 198–99 (testimony of Dr. Owens that "[m]ost upper level providers have had some degree of experience [inserting chest tubes].... The people who are in critical care situations are very well versed in them.").

¹⁹⁴ 300 ml is slightly more than 10 ounces. The UMC EMT testified that this procedure produced "the most [blood] I've ever seen out of a needle [thoracostomy]," and concluded that Tiara's "hemothorax was very very significant." Tr. 126. And yet it would not have been necessary if the physician had inserted a chest tube. *Id.* at 26. A needle thoracostomy is "a quick fix" only, performed "just to buy you some time," because it does not drain as much blood as a chest tube, and because the blood continues to flow into the lung. *Id.* at 26, 58–59, 127–28.

¹⁹⁵ This is approximately 2.5 liters of blood—a shocking amount.

18. At 8:52 p.m., Aubrey Anna was delivered by emergency Caesarean section, but showed no signs of life. CPR was continued on Tiara Clemons. At 8:54 p.m., another cardiac ultrasound was performed. With no cardiac activity noted, Tiara Clemons and Aubrey Anna Clemons were pronounced dead.

19. At all material times, Dr. Victoria Guevarra, Jill Shaw, FNP, and all other individuals who provided medical care and treatment to Tiara Clemons and Aubrey Anna Clemons were acting in the course and scope of their employment with the Choctaw Health Center, a healthcare facility owned and operated by, and located on property occupied by, the Mississippi Band of Choctaw Indians, in Choctaw, Mississippi.

*4 20. The United States of America, Defendant, is statutorily and at common law responsible for the wrongful and negligent acts, if any,¹⁹⁶ with respect to Tiara Clemons and Aubrey Anna Clemons which occurred at the Choctaw Health Center, located on property occupied by the Mississippi Band of Choctaw Indians, in Choctaw, Mississippi.¹⁹⁷

21. As the sole wrongful death beneficiaries of Tiara Clemons and Aubrey Anna Clemons, deceased, Elona Clemons and Keontray Clemons, by and through Kathy Clemons and Bill Clemons, Guardians, are entitled to assert and prosecute a claim for damages arising out of the wrongful death of Tiara Clemons and Aubrey Anna Clemons.

22. The care rendered to Tiara and Aubrey Anna Clemons on June 27, 2009 did not comply with, and fell below, the standard of care applicable to the Choctaw Health Center, and Dr. Guevarra.

23. Dr. Guevarra and the Choctaw Health Center breached the applicable standard of care while rendering medical care and treatment to Tiara and Aubrey Anna Clemons. The breach of the standard of care included a failure to timely transfer Tiara and Aubrey Anna to a healthcare facility with additional treatment capabilities, and/or failing to insert a chest tube, i.e., perform a thoracostomy, to protect Tiara Clemons' airway.

24. Had Tiara and Aubrey Anna Clemons received treatment at the Choctaw Health Center consistent with the applicable standard of care, i.e., timely transfer to a healthcare facility with additional treatment options available and/or insertion of a chest tube, both Tiara and Aubrey Anna Clemons would have survived intact.

¹⁹⁶ While this stipulation hedges on the existence of any wrongful or negligent acts by using the term "if any," the United States conceded liability shortly before trial. Stipulation Nos. 22–25 confirm that employees of the United States breached the standard of care, causing Tiara and Aubrey Anna's deaths.

¹⁹⁷ The government has explained the situation as follows: The CHC is a Section 638 contract facility (Public Law 93–638), operated pursuant to the Indian Self–Determination and Education Assistance Act, 25 U.S.C. § 450f(a) (1994). The Act provides that tribes may enter into self-determinative contracts with the Secretary of the Interior and the Secretary of Health and Human Services (HHS) to administer programs or services that otherwise would be administrated by the federal government. For the purposes of 42 U.S.C. § 233, such tribal facilities are deemed part of the Public Health Service, and their employees are deemed Public Health Service Employees while acting within the scope of their employment in carrying out the contract. The FTCA provides the exclusive remedy for any related claims. However, neither the Department of the Interior or HHS has any authority or input to the employment of any person providing care at such facilities. Their employment is exclusively a matter of tribal control. While HHS could arguably decertify a facility such as CHC, such action would involve political decisions at the highest level of the federal government and would be characterized as actions between nations, i.e. the United States and the Choctaw Tribe. Any amounts paid as damages in the present case will come from the judgment fund of the United States and not from the Choctaw Tribe. Docket No. 61, at 4 n. 2.

25. The breaches of the standard of care of Dr. Guevarra and the Choctaw Health Center while rendering medical care and treatment to Tiara Clemons and Aubrey Anna Clemons were a proximate cause of the deaths of Tiara Clemons and Aubrey Anna Clemons.

26. On June 27, 2009, Tiara Clemons was stabbed by an individual, consistent with the notations in the medical records and autopsy report.¹⁹⁸

27. The medical expenses associated with Tiara Clemons and Aubrey Anna Clemons treatment at University Medical Center on June 27, 2009 and the funeral expenses of Tiara Clemons and Aubrey Anna Clemons were paid by the Mississippi Band of Choctaw Indians.

28. Subsequent to June 27, 2009, Dr. Guevarra was removed from staffing the emergency room at Choctaw Health Center as an emergency physician.¹⁹⁹

II. The Court's Findings

This wrongful death suit was brought pursuant to the Federal Tort Claims Act (FTCA), 28 U.S.C. § 2671 *et seq.* [***] *5 Under Mississippi's wrongful death law, Kathy Clemons is an appropriate representative to file suit on behalf of herself and Tiara Clemons' children. Miss. Code § 11-7-13; PX-34; PX-35. The statute states that she "shall recover such damages allowable by law as the jury may determine to be just, taking into consideration *all the damages of every kind to the decedent and all damages of every kind to any and all parties interested in the suit.*" Miss. Code § 11-7-13 (emphasis added). "Compensation in a wrongful death action is not limited to actual damages and lost wages, but extends to the pain and suffering of the deceased, as well as the loss of companionship and society." [c]

Kathy Clemons may recover for the wrongful deaths of Tiara and Aubrey Anna with no distinction made for Aubrey Anna being a 30-week old fetus in the womb. Mississippi's wrongful death statute states that recovery may be made for the wrongful death of persons or "any unborn quick child." Miss.Code § 11-7-13; *see [c]* ("When a family loses a potential member because of tortious conduct of another, it suffers an injury of the same order as when it loses an existing member."). It is undisputed that Aubrey Anna was 'quick in the womb' and viable outside of the womb. Tr. 183, 200 (testimony of Dr. Owens); [c] (discussing 'quickening' and viability). Accordingly, Kathy Clemons may recover for the wrongful deaths of both Tiara and Aubrey Anna.

Before continuing, the Court must emphasize that its determination of the amount of damages properly recoverable in this case is in no way a declaration of the value of Tiara or Aubrey Anna's lives. It is

¹⁹⁸ The individual is Tiara's sister, Marena Clemons, who for her act was charged with a crime under tribal law and served time in the tribe's custody. Tr. 176-77. For several factual and legal reasons, however, Marena is not liable for Tiara and Aubrey Anna's deaths. The facts show that the stab wound was relatively minor and not the proximate cause of the deaths. The paramedic dispatched to the Clemons' home testified that Tiara's stab wound "was just a slit in the skin" that did not look bad and was not bleeding. Id. at 92-93. At that point Tiara was breathing well, had normal vital signs, and did not want to go to the hospital. Id. at 93, 95. Her mother testified that Tiara was calm and not experiencing any physical difficulties then. Id. at 164-65. The injury should have been easy to repair and resolve. Further, as will be discussed later, the parties agree that under Mississippi law, "no fault or responsibility for the death of Tiara or Aubrey Anna Clemons can be apportioned or assigned to Marena Clemons or any other intentional tortfeasor for purposes of reducing or mitigating liability attributable to the United States for the deaths, or damages owed by the United States to the wrongful death beneficiaries." See Part III, *infra*; Docket No. 61, at 9.

¹⁹⁹ Dr. Guevarra continued to staff the emergency room at Choctaw Health Center for several months after Tiara and Aubrey Anna's deaths. PX-49 at 174.

not possible to assign a dollar value to anyone's life. As the Mississippi Supreme Court wrote over 80 years ago, "the loss sustained by a wife and children in the death of the husband and father frequently cannot be compensated by any amount of money." *Gulf Ref. Co. v. Miller*, 121 So. 482, 483 (Miss.1929); see also *Dickey v. Parham*, 331 So.2d 917, 919 (Miss.1976) ("how to test the adequacy or inadequacy of verdicts in a wrongful death action is a most perplexing problem. This is true because the value of human life even when considered along with applicable elements of damages is difficult of proof."); Weems & Weems, Mississippi Law of Torts § 14:10 (2d ed.2008).²⁰⁰ An award of monetary damages is simply the means by which our system of justice seeks to repair some of the loss and harm inflicted upon the victim and the victim's family.

The parties' various disputes concerning damages are resolved as follows:

A. Economic Damages

Mississippi law defines economic damages as:

objectively verifiable pecuniary damages arising from medical expenses and medical care, rehabilitation services, custodial care, disabilities, loss of earnings and earning capacity, loss of income, burial costs, loss of use of property, costs of repair or replacement of property, costs of obtaining substitute domestic services, loss of employment, loss of business or employment opportunities, and other objectively verifiable monetary losses. *6 Miss.Code § 11-1-60(1)(b).

The plaintiff put forward evidence of \$31,394 in reasonable and necessary medical expenses and \$4,014 in funeral expenses. The United States does not challenge either amount. They will be awarded.

1. Tiara's Economic Damages

The plaintiff called Dr. G. Richard Thompson to provide expert testimony about Tiara's economic damages, while the defendant called James A. Koerber for the same purpose. The Court will take up lost earnings first, then turn to the value of household services.

The experts' estimates of Tiara's lost earnings differed based upon their assumptions. For example, the plaintiff's expert's report had a high-end estimate of \$1.19 million, PX-31 at 8, while the defendant's expert's low-end estimate was \$256,497, DX-1 at App'x A. (All of these figures have been reduced to present value.) The Court will wade through several of these assumptions and determine which model is generally more persuasive.²⁰¹

²⁰⁰ This case magnifies the enormous difficulties inherent in wrongful death damages awards. Somehow dollar amounts must be assigned to the grief the decedents' loved ones endured because of the medical providers' negligence. As noted by one commentator: "Grief is a readily foreseeable and very real consequence of wrongful death. It can kill a human spirit as effectively as a motor vehicle crash can still a beating heart. Survivors of persons lost to sudden violent death suffer not only the lifetime loss of their loved one, but trauma induced by the loss and the manner in which it occurred." Andrew J. McClurg, *Dead Sorrow: A Story About Loss and a New Theory of Wrongful Death Damages*, 85 B.U. L. Rev. 1, 9-10 (2005). In addition, Tiara and Aubrey Anna actually endured pain and suffering prior to their deaths. In fact, Tiara saw death, but she could not turn her head or do anything to slow or stop it, which must have increased her anxiety. She was not here to testify about the emotion and feeling which engulfed her during this tragedy. The difficulty of placing a dollar figure on these and other intangibles does not escape the Court.

²⁰¹ The Court is necessarily constrained by its inability to conduct its own analysis. It cannot decide that one expert's take on two variables is better reasoned, import them into another expert's overall more compelling approach, and re-

The first dispute concerns the number of years Tiara could be expected to work. The plaintiff's expert assumed, based on certain sources, that Tiara would work until the normal retirement age of 67. PX-31 at 5. The defendant's expert assumed, based on other sources, that Tiara would work for approximately 21 and a half years. DX-1 at 6. The defense expert's assumption was based upon a study of "initially inactive women with less than a high school education." DX-1 at 10. Tiara did have some work experience, so it is not immediately obvious that she matches the "initially inactive" description. But grouping Tiara with the findings of that study is also not quite apt because the evidence indicated that Tiara was completing her GED, and therefore should be treated as a high school graduate, not a high school dropout. See *Rebelwood Apartments RP, LP v. English*, 48 So.3d 483, 495-96 (Miss.2010) (discussing caselaw affirming trial judge's decision to apply college-graduate average wages to decedents who were enrolled in college but had not yet completed college). All in all, the plaintiff's expert's assumption is more compelling on this point. [***]

Another disputed assumption is Tiara's expected tax rate. The plaintiff's expert testified that with three children and relatively modest earnings, Tiara's taxes would be negligible. Tr. 230-31, 239; PX-31 at 6. The defendant's expert assumed a greater rate, especially if Tiara went on to obtain a two-year degree. DX-1 at 6. The Court agrees that the former approach more closely matches our situation.

The contested assumption of most significance is how much education Tiara ultimately would have completed. Lifetime wages for graduates of community colleges are, on average, higher than lifetime wages for GED recipients. PX-31; DX-1; Tr. 235-36. As a result, each expert made two calculations, one for Tiara completing community college and one for her without that credential. Within that latter category, the experts appear to have made a further distinction: the plaintiff's expert assumed Tiara's wages as a GED holder, while the defense expert assumed Tiara's wages in a minimum wage-only job. Compare PX-31 at 6 with DX-1 at 6.

*7 On review, the available evidence was more supportive of Tiara completing her GED and entering the workforce without a two-year degree. Tiara's mother testified that after completing her GED, which Tiara was only two classes away from finishing, Tiara had said she would work for the tribe and raise her children. Tr. 175. On prompting by counsel, testimony was elicited that Tiara wanted to attend college, but the answer soon returned to working for the tribe and raising children. *Id.* at 178. Given the testimony and evidence, it is more likely that Tiara would have completed her GED and returned to the workforce directly. (Even though it is possible for a non-high school graduate, non-GED holder to enroll in community college in Mississippi.) See *id.* at 174-78; DX-4. At the same time, the Court disagrees with the defense expert's apparent restriction of Tiara to minimum wage-only jobs, and adopts the range of wages applicable to GED holders.²⁰²

All in all, the Court will adopt the plaintiff's expert's general model, credit the defendant's argument as to Tiara's reasonably expected education level, and accept the plaintiff's expert's reduction at trial (based upon the personal consumption rate), to assess Tiara's economic damages at \$740,764. Tr. 241, 254-55.

run the model. Instead, the Court can choose between variables only where the experts have provided differential analyses; and then, from what remains, select the more persuasive overall analysis.

²⁰² Another reason Tiara should not be limited to minimum wage jobs is that one of her prior employers paid her more than the minimum wage. Tr. 329.

Finally, both parties' experts agreed that a component of Tiara's economic damages should be \$133,969 in lost household services. Those damages will be awarded.

Consequently, Tiara's economic damages are \$874,733.

2. Aubrey Anna's Economic Damages

Again, the calculation will be broken down into lost earnings and lost household services.

The Court's general assessment of the competing expert models applies to Aubrey Anna's lost earnings. The plaintiff's expert's overall model will be applied and reduced to take into account Aubrey Anna's expected personal consumption rate. The most significant question remaining concerns Aubrey Anna's education level: would she have completed high school before entering the workforce, or gone on to complete a two-year degree?

It is impossible to answer this question with certitude. Aubrey Anna had no education or work history upon which to base a conclusion about her lost earnings. That does not preclude an award of damages, of course. *See TXG Intrastate Pipeline Co v. Grossnickle*, 716 So.2d 991, 1016–17 (Miss.1997) (“It is well recognized that Mississippi is equally firm in its determination that a party will not be permitted to escape liability because of the lack of a perfect measure of damages his wrong has caused... Where the existence of damages has been established, a plaintiff will not be denied the damages awarded by a fact finder merely because a measure of speculation and conjecture is required in determining the amount of damages.”) (quotation marks, citations, and brackets omitted); *see also Choctaw Maid Farms, Inc. v. Hailey*, 822 So.2d 911, 918 (Miss.2002) (“there is no exact yardstick for determining [lost income] damages”) (quotation marks, citation, and brackets omitted). But it does mean the Court must weigh carefully the evidence, as well as guidance from other courts.

***8** For these situations, the Mississippi Supreme Court has provided the following guidance:

The conclusion by the Court of Appeals that the income for the children should be based on some sort of average income for persons of the community in which they lived, as far as we can find, has no basis in our law. Additionally, such a method is just as speculative as basing the recovery on the earning history of the parents. It is both unfair and prejudicial to ground the projected future income of a deceased child on either basis. Both methods result in potentially disparate recoveries for children from affluent communities or with affluent parents, as opposed to children from less affluent areas or with less affluent parents.

Who is to say that a child from the most impoverished part of the state or with extremely poor parents has less of a future earnings potential than a child from the wealthiest part of the state or with wealthy parents? Today's society is much more mobile than in the past. Additionally, there are many more educational and job-training opportunities available for children as a whole today. We must not assume that individuals forever remain shackled by the bounds of community or class. The law loves certainty and economy of effort, but the law also respects individual aptitudes and differences.

Therefore, we hold that in cases brought for the wrongful death of a child where there is no past income upon which to base a calculation of projected future income, there is

a rebuttable presumption that the deceased child's income would have been the equivalent of the national average as set forth by the United States Department of Labor. This presumption will give both parties in civil actions a reasonable benchmark to follow in assessing damages. Either party may rebut the presumption by presenting relevant credible evidence to the finder of fact. Such evidence might include, but is certainly not limited to, testimony regarding the child's age, life expectancy, precocity, mental and physical health, intellectual development, and relevant family circumstances. This evidence will allow the litigants to tailor their proof to the aptitudes and talents of the individual's life being measured. *Greyhound Lines, Inc. v. Sutton*, 765 So.2d 1269, 1276–77 (Miss. 2000).

It follows that this Court cannot base Aubrey Anna's expected education level upon her mother's education level. Such a conclusion would be at odds with the greater number of opportunities available to Aubrey Anna and other children in her generation. *See id.* And there is no "relevant credible evidence" from either party to bolster or rebut the presumption of using national benchmarks. *Id.* The defendant was given ample opportunity to rebut the presumption but failed to do so.

If the Mississippi Supreme Court is correct that we live in a more upwardly-mobile society, with "many more educational and job-training opportunities available for children" today than in the past, it is reasonable to expect Aubrey Anna to somewhat exceed her mother's educational achievement. *Id.* The Court may also take judicial notice of America's history of increased educational attainment, *i.e.*, the fact that over time the percentage of the population that graduates from high school and college has risen substantially.

*9 For example, between 1940 and 2009 there was "more than a three-fold increase in high school attainment and more than a five-fold increase in college attainment." U.S. Census Bureau, *Educational Attainment in the United States: 2009*, at 1, Feb. 2012, available at <https://www.census.gov/content/dam/Census/library/publications/2012/demo/p20-566.pdf>. The graphical representation of this trend shows that the increase is fairly consistent and continues to present day—or, more accurately, to 2009, the most recent year data were available. *Id.* at 3; *see generally* Gage Raley, *Yoder Revisited: Why the Landmark Amish School Case Could—And Should—Be Overturned*, 97 Va. L. Rev. 681, 696–97 (2011) (collecting figures showing a substantial increase in educational attainment in the United States over the past 35 years, and attributing the dramatic rise to a stronger, more direct "link between secondary education and business," the fact that "more jobs now demand greater educational skills," "[i]ncreasing global competition," and states' recognition that they are engaged in an "educational arms race") (quotation marks and citations omitted); Bill Ong Hing, *NAFTA, Globalization, and Mexican Migrants*, 5 J.L. Econ. & Pol'y 87, 136 (2009) ("Younger and older workers alike are now more educated as the share of adult native-born men without a high school diploma have plunged, from 53.6% in 1960 to 9.0 [%] in 1998. During that same period, the share with college degrees has gone up from 11.4% to 29.8%.") (citation omitted).

It bears repeating that no one, not even the capable experts who testified in this suit, can predict accurately what Aubrey Anna would have earned had she survived. She was only 30 weeks old. The Court—which has been given only two options, high school completion or two-year degree holder—must make a reasonable guess informed by prior caselaw, national averages, and long-term trends. It concludes that Aubrey Anna would more likely than not move at least one rung up the ladder of

economic opportunity. As a result, her grandmother will be awarded \$773,280 for lost earnings.²⁰³ See Tr. 243–44.

The parties dispute whether the plaintiff may recover the value of Aubrey Anna’s lost household services. The plaintiff’s expert recommended that they be awarded on essentially the same terms as Tiara’s lost household services. Tr. 245. The defendant’s expert thought none were warranted because of an assumption that Aubrey Anna would live alone. DX–2 at 15. Testimony supported that Aubrey Anna would probably not live alone. Tr. 158–60. The plaintiff will be awarded \$133,969 for Aubrey Anna’s lost household services.

As a result, Aubrey Anna’s total economic damages are \$907,249.

B. Non-Economic Damages

Mississippi law defines non-economic damages as:

subjective, nonpecuniary damages arising from death, pain, suffering, inconvenience, mental anguish, worry, emotional distress, loss of society and companionship, loss of consortium, bystander injury, physical impairment, disfigurement, injury to reputation, humiliation, embarrassment, loss of the enjoyment of life, hedonic damages, other nonpecuniary damages, and any other theory of damages such as fear of loss, illness or injury. *10 Miss. Code § 11–1–60(1)(a).

1. Tiara’s Pain and Suffering

At trial, the plaintiff called Dr. Michael Stodard to provide expert testimony on Tiara’s condition. Dr. Stodard testified that Tiara’s stab wound caused air and blood to flow into her chest cavity and slowly fill up the space normally occupied by her lung, causing respiratory distress. Tr. 22–24, 31, 43; PX–27 at 4. In addition, as the air and blood collected, they started to press against Tiara’s lung and heart, which pushed the lung toward collapse and impeded the heart’s ability to fill up and pump blood. Tr. 23–24.

Dr. Stodard testified that respiratory distress results in shortness of breath, suffocation, feelings of smothering, anxiety, restlessness, and “a sense of impending doom.” *Id.* at 24–25. Not only does the patient know that their breathing is impaired, but the body’s failure to oxygenate—how the lungs exchange oxygen into red blood cells, and the heart pumps that blood around the body—makes the patient feel like they are going to die. *Id.* at 25. Shock and a steadily decreasing blood pressure can result as the distress escalates. *Id.* Dr. Stodard explained that all of these symptoms could have been stopped with insertion of a chest tube, which provides immediate relief by draining the chest cavity and permitting the lung to expand. *Id.* at 26, 28.

²⁰³ The Court makes this finding notwithstanding the parties’ unnecessarily myopic perspective on Aubrey Anna’s expected educational attainment. The problem was illuminated most clearly when counsel for the plaintiff cross-examined the defendant’s expert economist. The expert failed to reconcile how in another case he had assumed that a deceased five-year old could have attended a four-year college, but here would not assume that Aubrey Anna, a 30-week old fetus, could have attended a four-year college. See Tr. 295–96, 304; see PX–55, at 5. Further, when questioned by the Court, the expert admitted that “most economists” would include a scenario where the child would finish college. Tr. 304. Yet here no such scenario was presented by either side’s expert economist. Both parties should have considered whether Aubrey Anna could have attended a four-year college.

Tiara was in distress by 5:42 P.M. and reported a 10 out of 10 pain level at that time. *Id.* at 37; PX–36 at 1. Dr. Guevarra testified in a deposition that Tiara was “screaming from pain and very restless,” and in obvious pain and distress. PX–49 at 133, 170–71. By 6:40 P.M., Tiara had gone into shock and had an abnormally low blood pressure because too much of her blood was in her chest cavity and not circulating through her body. Tr. 44. Dr. Stodard testified that she was experiencing extreme anxiety and distress, accompanied by a feeling of suffocation and impending doom. *Id.* at 45.

By 7:00 P.M., a chest x-ray ... showed that approximately half of Tiara’s blood was in her chest cavity, indicating that she was in hemorrhagic shock.²⁰⁴ *Id.* at 48, 56; *see id.* at 119. That condition is associated with greater physical and emotional suffering, including feelings of smothering. *Id.* at 49, 119.

Half an hour later, Tiara was gasping for breath and likely felt like she was drowning, Dr. Stodard said. *Id.* at 52, 80. She could not lay flat because the blood in her chest would have increased the pressure on her heart. *Id.* at 54. Instead, she was upright and leaning forward slightly in the tripod position, which helps keep blood away from the heart.²⁰⁵ *Id.*; *see id.* at 102 (testimony of EMT), 166 (testimony of UMC EMT). She told the UMC EMT that she was hurting and having a hard time breathing, and later begged, “please help me.” *Id.* at 117, 123. At one point, her mother testified, Tiara looked to be in fear of dying and said she was scared. *Id.* at 167–68. Dr. Guevarra admitted that Tiara was crying out for help. PX–49 at 172.

***11** Dr. Stodard testified that Tiara’s death was a slow process, during which she was conscious and aware of what was going on around her, as well as conscious of her own mortality. Tr. 56, 75–76. Later administration of a sedative (morphine) and a paralytic rendered Tiara unconscious and paralyzed until her death. *Id.* at 82, 147.

At times, the defendant argued that Tiara suffered relatively little because morphine was provided at or around 5:45 P.M., and also because Tiara became unconscious while being evacuated to UMC. *Id.* at 323, 325; *see* Stipulation No. 5. But the considerable evidence recited above shows the degree of her pain and suffering between the first administration of morphine and her later, final fall into unconsciousness. At other times, in fact, the defendant did not deny that Tiara’s death was slow and painful, and that she was conscious of it. Tr. 75. It later acknowledged the pain, significant difficulty breathing, and “awful” panic she suffered. *Id.* at 323, 325.

Taking all of this into account, the evidence shows that Tiara suffered tremendously, both physically and mentally, before dying. The Court will award \$1.5 million for her pain and suffering and \$500,000 for her mental anguish. *See Motorola Comm. & Electronics, Inc. v. Wilkerson*, 555 So.2d 713, 724 (Miss.1989); *see also Hailey*, 822 So.2d at 927–28 (Cobb, J., concurring in part and dissenting in part).

This award is lower than those in other, reasonably similar cases. ... Tiara’s lower award is not disproportionate or unreasonable.

²⁰⁴ The evidence shows that Tiara needed additional blood in order to keep blood circulating through her body. PX–52 at 39–43. The Choctaw Health Center, though, had no blood on hand and no place to keep blood. PX–49 at 158; *see also* PX–6 at 3 (Defendant’s Responses to Plaintiff’s First Request for Admissions). Nor did it have a machine that could take Tiara’s recovered blood and re-circulate it through her body. PX–52 at 42.

²⁰⁵ There was some discussion at trial about the tripod position being a natural or instinctive stance the body adopts to facilitate breathing. Tr. 136.

2. Aubrey Anna's Pain and Suffering

The plaintiff introduced, via deposition, the expert testimony of Dr. John P. Elliott, a specialist in maternal fetal medicine, which is also known as high-risk obstetrics. PX-52, at 7. Dr. Elliott testified that Aubrey Anna was entirely dependent upon Tiara receiving adequate oxygen. *Id.* at 25. When Tiara's oxygen supply was restricted, Aubrey Anna's health also suffered. *Id.* at 31.

***12** For example, Aubrey Anna's heart rate, which was recorded via fetal heart monitor once at 5:45 P.M. and once more at a later (unknown) time, showed increased stress as a result of Tiara's deteriorating condition. *Id.* at 30-31. (Dr. Guevarra admitted as much at her deposition. PX-49 at 134.) As Dr. Elliott put it, Aubrey Anna "was responding to stress by increasing [her] heartbeat. Probably the lack of oxygen that was going on with the mother was affecting the baby at that point, and the baby is pumping its blood faster to get more oxygen per minute." PX-52 at 31.

The lack of oxygen in Tiara's body caused a placental abruption—which means part of the placenta separated from Tiara's uterus—and fatally decreased the oxygen being delivered to Aubrey Anna. *Id.* at 25-26, 52. In short, Aubrey Anna died from a lack of oxygen. *Id.* at 52. Her time of death was most likely when Tiara went into cardiac arrest in the helicopter, within 15 minutes of her arrival at UMC.²⁰⁶ *Id.* The doctors at UMC delivered Aubrey Anna stillborn. *Id.* at 50-51.

The defendant asserted that Aubrey Anna "just passed out, went to sleep" without pain or suffering. Tr. 76, 325. "In fact, ... more than likely what she did was slowly become deprived of oxygen and just lose whatever consciousness she had. There was no—there was no impact, there was no prodding, no needlesticks, nothing. She just lost oxygen and went to sleep." *Id.* at 326. The evidence, though, showed that a 30-week old fetus has well-developed reflexes and can respond to stimuli like touch. *Id.* at 201, 204. Dr. Elliott, meanwhile, testified that Aubrey Anna's heart rate increased as her body was stressed from a lack of oxygen. PX-52, at 30-31. Aubrey Anna's body responded to the lack of oxygen that was killing her by working harder and straining itself. As she was dying, her body displayed its instinctive will to live.

The defendant's argument that Aubrey Anna merely "went to sleep" glosses over the medical reality that, to borrow defense counsel's own words, "more than likely what [Aubrey Anna] did was slowly become deprived of oxygen." Tr. 326. Another way to describe a deprivation of oxygen is "suffocation." Webster's Third New International Dictionary (Unabridged) 2285 (1993) (defining suffocate as "to stop the respiration of (as by strangling or asphyxiation): deprive of oxygen: make unable to breathe."). Suffocation is obviously painful.

It is more likely than not that Aubrey Anna experienced physical pain and suffering before her death. The Court will award \$650,000 for that pain and suffering.

3. Loss of Society and Companionship

Tiara's two surviving children, seven-year old Elona and five-year old Keontray, are entitled to damages for the loss of society and companionship of their mother. The defendant argues that no such damages may be awarded because "Mississippi does not recognize damages for past and future loss of

²⁰⁶ These 15 minutes could easily have been made up for earlier. Recall that Tiara had waited approximately 90 minutes in the Choctaw Health Center before Dr. Guevarra attempted to arrange a transfer to a better-equipped hospital.

society and companionship for a child upon the loss of a parent.” Docket No. 61, at 8 (citing *Thompson v. Love*, 661 So.2d 1131 (Miss.1995)) (emphasis omitted).

***13** *Thompson* was a personal injury case where the parent did not die. In wrongful death cases like ours, though, children are permitted to recover loss of society and companionship damages for the death of a parent. *Long v. McKinney*, 897 So.2d 160, 169 (Miss. 2004) (“The beneficiaries are entitled to recover for their respective claims of loss of society and companionship.”); *Thompson*, 661 So.2d at 1136 (McRae, J., dissenting) (explaining difference between loss of companionship recovery in personal injury and wrongful death contexts); Jackson & Miller, 4 Encyclopedia of Mississippi Law § 25:18 (2001). Accordingly, Elona and Keontray will each be awarded \$750,000 for the loss of society and companionship of their mother.

The plaintiff also seeks damages for Elona and Keontray’s loss of society and companionship of their sister, Aubrey Anna. Such damages have long been permitted by the Mississippi Supreme Court. *E.g.*, *Miller*, 121 So. at 484 (observing that the decedent, a young boy, was “the pride of his father, the joy of his mother, the idol of his sisters, and the boon companion of his brothers”); *Gulf, M. & O.R. Co. v. White*, 68 So.2d 458, 460 (1953) (“where the interested parties suing for the death of another are the brothers and sisters of the deceased, loss of companionship may be considered as an element of damages”).

Here, the defendant’s specific argument is that the claim fails because there was “no proof of any preexisting relationship between Aubrey Anna Clemons prior to her death and her siblings that could be characterized as affectionate or devoted.” Docket No. 61, at 8. But, *of course* there was no preexisting relationship between Aubrey Anna and her siblings—she had not been born yet. The defendant deprived the siblings of the opportunity to form a relationship and do all the things that sisters and brothers do with each other, as well as experience the simple joys of life that siblings share.

The defendant’s argument has not taken into account the Mississippi Legislature’s decision in 2004 to amend the wrongful death statute to permit recovery for “the death of any person *or of any unborn quick child*.” Miss. Code § 11–7–13 (emphasis added); *see* 2004 Miss. Laws Ch. 515 (H.B.352). The amendment suggests that the legislature intended beneficiaries of unborn children who die a few weeks shy of birth to be treated akin to beneficiaries of children who die a few weeks after birth. A contrary interpretation would render meaningless the legislature’s repeated addition of the phrase “unborn quick child” to the wrongful death statute. Aubrey Anna’s siblings will each be awarded \$400,000 for the loss of society and companionship of their sister.

Kathy Clemons has also lost the society and companionship of her daughter and granddaughter. She testified that when she arrived at UMC and was told that Tiara and Aubrey Anna had died, it all went “blank.” Tr. 169–71. “It’s always cold and hard,” she said. *Id.* at 171. “I wouldn’t have ever thought I would lose my child like this.” *Id.* Dr. Owens, who met with Kathy Clemons and her family at UMC to explain what had happened, reported that they were distraught and that not much registered. *Id.* at 198. “They were very clearly just emotionally devastated.” *Id.*

***14** On this basis, Kathy Clemons will be awarded \$500,000 for the loss of society and companionship of her daughter Tiara and granddaughter Aubrey Anna. *See Gatlin v. Methodist Med. Ctr., Inc.*, 772 So.2d 1023, 1030 (Miss.2000).

4. Summary of Non–Economic Damages

The total award for non-economic damages is \$5.45 million. Although this amount exceeds the economic damages award of \$1,817,390, the ratio of economic damages to non-economic damages is well within acceptable boundaries.

The Mississippi Supreme Court has upheld damages with far greater disparities than the award in this case. *Estate of Jones v. Phillips*, 992 So.2d 1131, 1150 (¶ 52) (Miss. 2008) (upholding a \$5,000,000 verdict and finding although economic damages only totaled \$440,511.46, the amount of the verdict was not so excessive as to shock the conscience); *Gatewood v. Sampson*, 812 So.2d 212, 223 (¶¶ 25–27) (Miss. 2002) (upholding jury verdict of \$308,000 in compensatory damages although proof of lost wages and medical expenses only totaled \$8,002.50); *Dorrough v. Wilkes*, 817 So.2d 567, 575 (¶ 30) (Miss. 2002) (upholding jury verdict of \$1,500,000 although medical fees and loss of services only totaled \$339,000). *Kelly*, 88 So.3d at 780.

The 2.99x multiple in our case is lower than the 10.3x, 37.5x, and 3.4x ratios affirmed above.

5. Mississippi’s Cap on Non–Economic Damages [omitted]

6. The FTCA’s Administrative Limitation on Damages

Recall that before filing suit, plaintiff’s counsel mailed the United States a thorough Notice of Claim and two completed SF–95s—one for Tiara and one for Aubrey Anna. PX–4. Each SF–95 sought \$2.5 million in damages, for a total demand of \$5 million. *Id.* The plaintiff’s recovery in this case may not exceed that sum. 28 U.S.C. § 2675(b); *Corte–Real v. United States*, 949 F.2d 484, 487 (1st Cir. 1991) (collecting cases).

If Mississippi’s cap on non-economic damages is upheld and applied, the plaintiff will recover less than \$5 million, rendering the FTCA’s limit moot. On the other hand, if Mississippi’s cap is deemed unconstitutional, the FTCA’s limit will be applied to cap the plaintiff’s total recovery at \$5 million.

C. Punitive Damages

Punitive damages are not permitted under the FTCA. 28 U.S.C. § 2674. The plaintiff did not seek to recover them and the Court cannot award them. It will, though, observe that in addition to the evidence already described above, there is even more evidence that could have supported a finding of recklessness and an award of punitive damages. In other words, but for the fact that the government is the defendant, punitive damages would have been assessed.

One revealing piece of evidence is an April 17, 2009, letter from the Clinical Director of the Choctaw Health Center, Dr. C.V. Joshi, to the CEO of the Choctaw Health Center, in which Dr. Joshi warned the CEO about the Center’s condition and urged improvements in the Center’s care. PX–50 at 57–66 (deposition of Dr. Joshi); PX–17 (Dr. Joshi’s letter). The letter’s most salient points are reproduced here:

WITH [BUDGETARY] CUTS IT IS NECESSARY TO TAKE [A] SECOND LOOK AT [THE] LEVEL OF CARE WE CAN OFFER....

In last 10–15 years Emergency medicine in itself has become a separate medical speciality [*sic*]. These doctors are rigorously trained during their residency program in larger medical centers. These doctors are better equipped to handle critically ill patients

with heart attack, CVA; gun shot wounds and seriously hurt MVA patients. In order to stabilize critically ill ER patient some time availability of general surgeon, anesthesiologist, respiratory therapist, and internist with critical care experience and some time help of pediatrician is extremely necessary....

Emergency physicians at CHC are not full time ER physicians. Many of clinic physicians work part time in the emergency room. Even though these doctors take courses such as ACLS and PALS these courses and mock codes by no means substitute for day to day real life experience....

Our staff ... mainly consists of family physicians.... We do not have surgeon, anesthetist, and internist with ICU/CCU experience or pediatrician on staff. There fore there is no immediate back up for the ER physician....

***16 IN THE PAST I WAS ABLE TO EASE NEW PHYSICIAN AFTER SEVERAL MONTHS OF EXPOSURE TO UNDERSTAND OUR UNIQUE CULTURE, HEALTH PROBLEMS AND LIMITATIONS OF OUR FACILITY AND HOW TO PRACTICE SAFE MEDICINE IN HIGH RISK AREA SUCH AS EMERGENCY ROOM.**

IT IS TIME TO REEVALUATE OUR HEALTH DELIVERY SYSTEM AND MAKE GOVERNING BOARD AWARE ABOUT CHRONIC PROBLEMS

AFTER NEXT FEW WEEKS I THINK GIVING ADEQUATE QUALITY COVERAGE IS ALMOST DIFFICULT. PX-17, at 1-3.

No immediate action was taken. PX-50, at 60. Just a few weeks later, of course, Tiara Clemons was treated at Choctaw Health Center by a family physician who refused to perform a basic procedure. In short, Tiara Clemons was treated by a family physician who had no right to be in an emergency room, but even worse, was in charge of the emergency room, and her superiors knew it. As a result, Tiara and her baby suffered the unalterable consequence.

Additional evidence not discussed may also have supported an award of punitive damages, from Dr. Guevarra not knowing where the chest tube was physically located, to the fact that medical equipment Tiara needed had been broken (for an indefinite period) when she needed it. PX-49, at 59, 66, 69-70.

The bottom line is that serious deficiencies with the care offered at the Choctaw Health Center were known and discussed months before Tiara and Aubrey Anna's disastrous visit (*e.g.*, Dr. Joshi's letter), or should have been addressed and resolved beforehand (*e.g.*, the lack of functioning ER equipment). Had prompt action been taken, their deaths may never have occurred. Every justification for awarding punitive damages is present in this case.

[***] As a result of the defendant's breaches causing the deaths of Tiara and Aubrey Anna Clemons, the plaintiff is entitled to judgment against the defendant in the amount of \$1,817,390 in economic damages, in addition to non-economic damages to be determined after supplemental briefing, but in any event no less than \$500,000.

IV. For the foregoing reasons, the Court finds in favor of plaintiff Kathy Clemons in the amount of \$1,817,390 in economic damages and at least \$500,000 in non-economic damages. ...

Note 1. Why do you think the opinion goes out of its way to point out the following: “[B]ut for the fact that the government is the defendant, punitive damages would have been assessed”? Do you agree with the court’s assessment that “[e]very justification for awarding punitive damages is present in this case”?

Note 2. This judicial opinion at times reads like an episode of the tv program, ER (or any other medical drama), albeit one with an unhappy ending. Why do you think it goes into so much factual detail when liability has been conceded ab initio (from the start)?

Note 3. Not all courts are disposed to award significant damages for the loss of a fetus on the grounds of loss of companionship by existing siblings. What do you think is the right balance for tort law to strike?

Note 4. Given what you know about the apportionment of fault and damages, do you think it is reasonable that Tiara’s sister, an intentional tortfeasor who stabbed her, thus causing the initial injury, is excluded from the assessment of liability? Why or why not? What doctrines, or what rationales, support your conclusion? You might think back to *Smelser v. Paul* from Module 4 (a case involving allocation of damages related to a toddler’s injuries in light of parental immunity).

Note 5. A further critique of damages awards, on grounds of racial and social justice, is that they take a given status or fact at one point in time, and use that to predict future earnings and productivity without adjusting to account for progressive social changes such as increased access to institutions of higher education and correspondingly higher-paying employment. Accordingly, the standard approach fails to account for advances in social justice and increases in socioeconomic equity and thus entrenches inequities. What, if anything, can and should tort law do about this problem? How did this court approach the issue, and what did you think, descriptively and normatively, of its approach?

More generally, how proactive should tort law be in defining who can recover from the losses or deaths suffered by others? We have seen in the context of a wrongful death statute that a beneficiary interest may be created by statute for particular kinds of successors. Should the particular identity of the surviving members of the family unit be closely scrutinized? This is the question raised in the next case.

Langan v. St. Vincent’s was decided before *Obergefell v. Hodges*, 576 U.S. 644 (2015) struck down any state bans on same-sex marriage and bans on recognizing such marriages duly performed in other jurisdictions, holding them unconstitutional under the due process and equal protection clauses of the Fourteenth Amendment to the U.S. Constitution. But *Langan v. St. Vincent* offers lessons in how courts tread uncertain waters as they articulate the evolving interests of the state and the parties to a suit. In addition, the case offers practice balancing tort law’s interests and purposes with those of competing (or transcending) areas of law in the context of a dispute over statutory construction.

**Langan v. St. Vincent's Hospital of New York, Supreme Court, App. Div. 2d
Dept. (2005)
(25 A.D.3d 90)**

***91** The underlying facts of this case are not in dispute. After many years of living together in an exclusive intimate relationship, Neil Conrad Spicehandler (hereinafter Conrad) and John Langan endeavored to formalize their relationship by traveling to Vermont in November 2000 and entering into a civil union. They returned to New York and continued their close, loving, committed, monogamous relationship as a family unit in a manner indistinguishable from any traditional marital relationship.

In February 2002 Conrad was hit by a car and suffered a severe fracture requiring hospitalization at the defendant St. Vincent's Hospital of New York. After two surgeries Conrad died. ***92** The plaintiff commenced the instant action which asserted, inter alia, a claim pursuant to EPTL 5-4.1 to recover damages for the decedent's wrongful death. The defendant moved, inter alia, to dismiss that cause of action on the ground that the plaintiff and the decedent, being of the same sex, were incapable of being married and, therefore, the plaintiff had no standing as a surviving spouse to institute the present action. The Supreme Court, inter alia, denied that motion and the instant appeal ensued. For the reasons stated below, the Supreme Court's order must be reversed insofar as appealed from.

An action alleging wrongful death, unknown at common law, is a creature of statute requiring strict adherence to the four corners of the legislation [cc] The relevant portion of EPTL 5-4.1 provides as follows:

“The personal representative, duly appointed in this state or any other jurisdiction, of a decedent *who is survived by distributees* may maintain an action to recover damages for a wrongful act, neglect or default which caused the decedent's death” (emphasis added).

The class of distributees is set forth in EPTL 4-1.1. Included in that class is a surviving spouse. At the time of the drafting of these statutes, the thought that the surviving spouse would be of the same sex as the decedent was simply inconceivable and certainly there was no discriminatory intent to deny the benefits of the statute to a directed class. On the contrary, the clear and unmistakable purpose of the statute was to afford distributees a right to seek compensation for loss sustained by the wrongful death of the decedent [c].

Like all laws enacted by the people through their elected representatives, EPTL 5-4.1 is entitled to a strong presumption that it is constitutional [cc] (The plaintiff claims that application of the statute in such a manner as to preclude same-sex spouses as potential distributees is a violation of the Equal Protection Clauses of the Constitutions of the United States and the State of New York. However, any equal protection analysis must recognize that virtually all legislation entails classifications for one purpose or another which results in the advantage or disadvantage to the affected groups (*see Romer v. Evans*, 517 U.S. 620)). In order to survive constitutional scrutiny a law needs only to have a rational relationship to a legitimate state interest even if the ***93** law appears unwise or works to the detriment of one group or the other (*see Romer v. Evans, supra*). Thus, the plaintiff must demonstrate that the denial of the benefits of EPTL 5-4.1 to same-sex couples is not merely unwise or unfair but serves no legitimate governmental purpose. The plaintiff has failed to meet that burden.

In the absence of any prior precedent, the court would have to analyze whether the statute imposes a broad and undifferentiated disadvantage to a particular group and if such result is motivated by an animus to that group (*see Romer v. Evans, supra*). However, in this instance, it has already been established that confining marriage and all laws pertaining either directly or indirectly to the marital relationship to different sex couples is not offensive to the equal protection clause of either the Federal or State constitutions. In *Baker v. Nelson*, 291 Minn. 310, the Supreme Court of Minnesota held that the denial of marital status to same-sex couples did not violate the Fourteenth Amendment of the United States Constitution. The United States Supreme Court refused to review that result (*see Baker v. Nelson*, 409 U.S. 810). The plaintiff herein cannot meet his burden of proving the statute unconstitutional and does not refer this court to any binding or even persuasive authority that diminishes the import of the *Baker* precedent.

On the contrary, issues concerning the rights of same-sex couples have been before the United States Supreme Court on numerous occasions since *Baker* and, to date, no justice of that court has ever indicated that the holding in *Baker* is suspect. Although in *Lawrence v. Texas*, 539 U.S. 558, the Supreme Court ruled that laws criminalizing activity engaged in by same-sex couples and potentially adversely affecting their liberty interests could not withstand constitutional scrutiny, every justice of that court expressed an indication that exclusion of marital rights to same-sex couples did promote a legitimate state interest. Justices Scalia, Thomas, and Rehnquist concluded that disapprobation of homosexual conduct is a sufficient basis for virtually any law based on classification of such conduct. The majority opinion of Justices Kennedy, Stevens, Ginsberg, Souter, and Breyer declined to apply an equal protection analysis and nonetheless expressly noted that the holding (based on the penumbra of privacy derived from *Griswold v. Connecticut*, 381 U.S. 479) did not involve or require the government to give formal recognition to any relationship that homosexuals *94 wish to enter (*see Lawrence v. Texas, supra* at 578). Justice O'Connor, in her concurring opinion based on an equal protection analysis, specifically excluded marriage from the import of her conclusions, stating simply "... other reasons exist to promote the institution of marriage beyond mere moral disapproval of an excluded group" (*Lawrence v. Texas, supra* at 585).

Similarly, this court, in ruling on the very same issue in *Matter of Cooper*, 187 A.D.2d 128, *appeal dismissed*, 82 N.Y.2d 801, not only held that the term "surviving spouse" did not include same-sex life partners, but expressly stated as follows:

"Based on these authorities [including *Baker, supra*.], we agree with Acting Surrogate Pizzuto's conclusion that 'purported [homosexual] marriages do not give rise to any rights * * * pursuant to * * * EPTL 5-1.1 [and that] [n]o constitutional rights have been abrogated or violated in so holding'" (emphasis added)[c].

Although issues involving same-sex spouses have been presented in various contexts since the perfection of this appeal, no court decision has been issued which undermines our obligation to follow our own precedents. Recently, in the somewhat analogous case of *Valentine v. American Airlines*, 17 A.D.3d 38, the Appellate Division, Third Department, in denying spousal status to same-sex couples for purposes of Workers Compensations claims, cited both *Baker* and *Cooper* with approval. Thus, no cogent reason to depart from the established judicial precedent of both the courts of the United States and the courts of the State of New York has been demonstrated by the plaintiff or our dissenting colleagues.

The fact that since the perfection of this appeal the State of Massachusetts has judicially created such right for its citizens is of no moment here since the plaintiff and the decedent were not married in that jurisdiction. They opted for the most intimate sanctification of their relationship then permitted, to wit, a civil union pursuant to the laws of the State of Vermont. Although the dissenters equate civil union relationships with traditional heterosexual marriage, we note that neither the State of Vermont nor the parties to the subject relationship have made that jump in logic. In following the ruling of its Supreme Court in the case of *Baker v. State of Vermont*, 170 Vt. 194, the Vermont Legislature went to great pains to expressly decline to place civil unions and marriage on an identical basis. While affording same-sex couples the same rights as those afforded married couples, the Vermont Legislature refused to alter *95 traditional concepts of marriage (i.e., limiting the ability to marry to couples of two distinct sexes) (*see* Vt. Stat. Ann., tit. 15, § 8; Vt. Stat. Ann., tit. 15, § 1201 [4]). The import of that action is of no small moment. The decedent herein, upon entering the defendant hospital, failed to indicate that he was married. Moreover, in filing the various probate papers in this action, the plaintiff likewise declined to state that he was married. In essence, this court is being asked to create a relationship never intended by the State of Vermont in creating civil unions or by the decedent or the plaintiff in entering into their civil union. For the same reason, the theories of Full Faith and Credit and comity have no application to the present fact pattern.

The circumstances of the present case highlight the reality that there is a substantial segment of the population of this State that is desirous of achieving state recognition and regulation of their relationships on an equal footing with married couples. There is also a substantial segment of the population of this State that wishes to preserve traditional concepts of marriage as a unique institution confined solely to one man and one woman. Whether these two positions are not so hopelessly at variance (to all but the extremists in each camp) to prevent some type of redress is an issue not for the courts but for the Legislature. Unlike the court, which can only rule on the issues before it, the Legislature is empowered to act on all facets of the issue including, but not limited to, the issues of the solemnization and creation of such relationships, the dissolution of such relationships and the consequences attendant thereto, and all other rights and liabilities that flow from such a relationship. Any contrary decision, no matter how circumscribed, will be taken as judicial imprimatur of same-sex marriages and would constitute a usurpation of powers expressly reserved by our Constitution to the Legislature. Accordingly, the order must be reversed insofar as appealed from.

H. MILLER, J.P., and SCHMIDT, J., concur.

FISHER, J. dissents and votes to affirm the order with the following memorandum, in which CRANE, J., concurs:

The majority's forceful defense of the Legislature's prerogative to define what constitutes a marriage in New York seems to me to miss the point. This case is not about marriage. The plaintiff does not claim to have been married to the decedent, and clearly he was not, either under the laws of New York or in the eyes of Vermont.

What this case is about is the operation of a single statute—New York's wrongful death statute—that controls access to the courts for those seeking compensation for the loss of a pecuniary *96 expectancy created and guaranteed by law. The statute provides such access to a decedent's surviving spouse because the wrongful death of one spouse deprives the other of an expectation of continued support which the decedent would have been obligated by law to provide (*see e.g.* Family Ct. Act § 412; Social

Services Law § 101[1]).²⁰⁷ But, as applied here, the statute does not permit the surviving member of a Vermont civil union to sue for wrongful death, even though, like spouses, each member of the civil union is obligated by law to support the other (*see* Vt. Stat. Ann., tit. 15, § 1204[c]). The principal question presented, therefore, is whether, as it currently operates to permit spouses but not partners in a Vermont civil union to sue for wrongful death, the law draws a distinction between similarly-situated persons on the basis of sexual orientation and, if so, whether the distinction bears some rational relationship to any conceivable governmental objective promoted by the statute. Because I conclude that the statute as applied here does classify similarly-situated persons on the basis of sexual orientation without a rational relationship to any conceivable governmental purpose furthered by the statute, I respectfully dissent.

The facts are largely undisputed.

The plaintiff, John Langan, and the decedent, Neil Conrad Spicehandler, met in 1986 and soon began an intimate relationship that proved to be both stable and long lasting. Thirteen years later, they were living together in New York when the Supreme Court of Vermont issued its decision in *Baker v. State*, 170 Vt. 194. The Court held that the Common Benefits Clause of the Vermont Constitution (*see* Vt. Const., ch. I, art. 7) required that same-sex couples be granted the same statutory benefits and protections enjoyed by persons of the opposite sex who choose to marry, and it ordered the State to fashion a remedy to achieve that result [c].

As the majority correctly points out, Vermont’s Legislature responded by reaffirming the State’s traditional view that “[m]arriage’ means the legally recognized union of one man and one woman” (Vt. Stat. Ann., tit. 15, § 1201 [4]). It then established a new, parallel legal status, called a civil union, for same-sex couples not eligible to marry under Vermont law (*97 Vt. Stat. Ann., tit. 15, § 1202). The new legislation prescribed how a civil union could be established (*see id.*), and how it could be dissolved (*see* Vt. Stat. Ann., tit. 15, § 1206). And it provided that those who establish a civil union would have the same benefits, protections, and responsibilities as married couples had in Vermont (*see* Vt. Stat. Ann., tit. 15, § 1204[e]), including, importantly, the responsibility “for the support of one another to the same degree and in the same manner as prescribed under law for married persons” (Vt. Stat. Ann., tit. 15, § 1204[c]).²⁰⁸

In November 2000, approximately four months after Vermont’s civil union law went into effect, the plaintiff and the decedent traveled to Vermont with some 40 family members and friends and solemnized a civil union in a ceremony performed by a Justice of the Peace in accordance with Vermont law. After the ceremony, the plaintiff and the decedent returned to their home, and to their lives, in New York.

On February 12, 2002, the decedent was injured in midtown Manhattan by a hit-and-run driver. He was admitted to St. Vincent’s Hospital of New York (hereinafter St. Vincent’s) where he underwent two surgeries to address open fractures to his left tibia and fibula. At first, the plaintiff was told by

²⁰⁷ The statute does not limit wrongful death plaintiffs to spouses. Indeed, in some circumstances, because of their possible financial expectancy, the statute authorizes wrongful death suits by a decedent’s relatives as far distant as first cousin, once removed (*see* EPTL 4–1.1[a] [7]).

²⁰⁸ Effective October 1, 2005, Connecticut became the second State to allow same-sex couples to enter into civil unions conferring “all the same benefits, protections and responsibilities under law ... as are granted to spouses in a marriage” (Conn. Public Act No. 05–10, § 14).

hospital staff that the surgeries had been successful and that the decedent would be discharged. On the morning of February 15, 2002, however, the plaintiff received a telephone call from a physician at St. Vincent's informing him that the decedent had died.

The plaintiff subsequently commenced this action against St. Vincent's, both on his own behalf and as executor of the decedent's estate. As executor, he sought damages, inter alia, for medical malpractice and lack of informed consent. On his own behalf, he sought damages for wrongful death.

The defendant St. Vincent's moved, inter alia, to dismiss the wrongful death claim on the ground that the plaintiff was not the decedent's distributee and therefore could not recover damages for his wrongful death. The plaintiff cross-moved for summary judgment on the issue of his standing to assert the wrongful death claim. He argued that his status under Vermont's civil union law entitled him to sue as the decedent's surviving spouse.

In a detailed opinion, the Supreme Court denied St. Vincent's motion and granted the plaintiff's cross motion. The court found *98 that, because the plaintiff qualified as a surviving spouse under the laws of Vermont, he was included within the meaning of "spouse" as that term is used in New York's Estates, Powers and Trusts Law and therefore had standing to recover for the wrongful death of the decedent (*see Langan v. St. Vincent's Hosp. of New York*, 196 Misc.2d 440, 765 N.Y.S.2d 411). This appeal followed.²⁰⁹

New York's Estates, Powers and Trusts Law (hereinafter EPTL) allows an action for the wrongful death of any individual who is survived by one or more distributees, with the recovery to provide compensation for economic injuries suffered as a result of the death (*see* EPTL 5-4.1[1] and 5-4.4[a]). A distributee is any person who may be entitled under law to take or share in the decedent's property not disposed of by will (*see* EPTL 1-2.5 and 4-1.1). Distributees include certain of the decedent's blood relatives, his or her adopted children, and, unless disqualified, his or her "spouse" (*see* EPTL 4-1.1 and 5-1.2).

The majority writes that it would have been inconceivable to the drafters of the wrongful death statute that the surviving spouse would be of the same sex as the decedent. I agree.

Although the term "spouse" is not defined in the EPTL, its use in several provisions in that chapter leaves no doubt that it was intended to include only those persons joined together in marriage (*see Raum v. Restaurant Assoc.*, 252 A.D.2d 369, 370). For example, both sections 5-1.1(b)(1) and 5-1.1-A(b)(1) of the EPTL explicitly refer to "the date of the marriage" in determining whether a transaction benefitting the "spouse" constitutes a testamentary substitute. Similarly, both EPTL 5-1.1(f)(3)(A) and 5-1.1-A(e)(3)(A) provide, inter alia, that the waiver or release of the right of election is effective, whether executed "before or after the marriage of the spouses." And, perhaps most significantly, EPTL 5-1.2(a), (a)(1), and (a)(2) provide that, within the meaning and for the purposes of the wrongful death statute, "[a] husband or wife is a surviving spouse" unless, inter alia, "[a] final decree or judgment of divorce, of annulment or declaring the nullity of a marriage ... was in effect when the deceased spouse died," or "[t]he marriage was void as incestuous ..., bigamous ..., or a prohibited remarriage ..."

²⁰⁹ New York's Attorney General has submitted a brief amicus curiae urging affirmance, and the Court has received a second amicus brief, also urging affirmance, submitted by the Association of the Bar of the City of New York, and joined in by the New York County Lawyers' Association, the Women's Bar Association of the State of New York, and the New York Chapter of the American Academy of Matrimonial Lawyers.

*99 Significantly, although the EPTL has a number of different statutory sources, these particular sections—1–2.5, 4–1.1, 5–1.1, 5–1.2, and 5–4.1—all share a common predecessor in the Decedent Estate Law (*see* EPTL 14–2.1), and therefore call for a consistent reading of the word “spouse.” Clearly, then, the drafters of these EPTL sections contemplated that the word “spouse” would apply only to a person who had been married to the decedent at the time of death, and since the notion of same-sex marriage was largely unknown at the time, the majority is correct in saying that it would have been inconceivable to the drafters that the decedent and the surviving spouse would be of the same sex.

Indeed, even in more recent years, although New York’s Legislature has provided same-sex couples with certain rights and benefits, it has not seen fit to include them in the class of persons entitled to assert a wrongful death claim. For example, in the wake of the attacks of September 11, 2001, and more than two years after Vermont established civil unions, the Legislature declared, *inter alia*:

“that domestic partners of victims of the terrorist attacks are eligible for distributions from the federal victim compensation fund, and the requirements for awards under the New York State World Trade Center Relief Fund and other existing state laws, regulations, and executive orders should guide the federal special master in determining awards and ensuring that the distribution plan compensates such domestic partners for the losses they sustained” (L. 2002, ch. 73, § 1).

Subsequently, the Legislature enacted Workers’ Compensation Law § 4 for the specific purpose of providing death benefits to domestic partners of those killed on September 11, 2001 (*see* L. 2002, ch. 467, § 1). Indeed, the wrongful death statute itself was amended to lengthen the limitations period for the commencement of actions on behalf of decedents whose deaths were caused by the September 11th terrorist attacks (*see* EPTL 5–4.1, as amended by L. 2003, ch. 114, § 1). Yet the Legislature did not see fit to grant unmarried domestic partners the right to maintain an action to recover damages for wrongful death.

Because the wrongful death statute is in derogation of the common law, it must be strictly construed (*see Gonzalez v. New York City Hous. Auth.*, 77 N.Y.2d 663, 667). Thus, I agree with the majority that the term “spouse” as used in *100 EPTL 4–1.1 is limited to those persons who were married to a decedent at the time of death and cannot, through statutory construction, be interpreted expansively to include persons like the plaintiff and the decedent here who were partners in a Vermont civil union but were not joined in marriage (*see Matter of Cooper*, 187 A.D.2d 128).

As an alternative, the plaintiff attempts to invoke principles of equity to secure the right to bring this action. Relying on *Braschi v. Stahl Assoc. Co.*, 74 N.Y.2d 201, the plaintiff argues that, even if he does not expressly fall within the meaning of “spouse” as used in the EPTL, New York is nevertheless bound by considerations of equity to recognize his right to recover for the decedent’s wrongful death. In *Braschi*, the Court of Appeals was called upon to interpret a rent-control regulation providing that, upon the death of a tenant, the landlord may not dispossess “either the surviving spouse of the deceased tenant or some other member of the deceased tenant’s family who has been living with the tenant” (*id.* at 206 [quoting 9 NYCRR 2204.6(d)]). Noting that rent-control laws must be interpreted broadly to effectuate their purposes (*Braschi v. Stahl Assoc. Co.*, *supra* at 208), the Court held that the gay life partner of the deceased tenant could, under appropriate circumstances, fall within the meaning of the word “family” (*id.* at 211).

Unlike the non-eviction right at issue in *Braschi*, however, the right to assert a wrongful death claim is a vested property right [c] (that does not exist at common law or in equity. As a creature of statute, it must be founded on statutory authority (*see Liff v. Schildkrout*, 49 N.Y.2d 622, 632). Hence, if the plaintiff does not qualify as a “distributee” under the EPTL, he cannot otherwise assert a wrongful death claim under general principles of equity.

The majority appears to conclude that, simply because the plaintiff and the decedent were not married, “the theories of Full Faith and Credit and comity have no application.” It is certainly true that the constitutional requirement of Full Faith and Credit need not be considered here, if for no other reason than that the plaintiff has specifically disavowed reliance on it.²¹⁰ But the plaintiff and amici do strongly argue that New York is *101 bound to afford the plaintiff the right to sue for wrongful death because the doctrine of comity requires recognition of the “spousal rights” he derives from the laws of Vermont. I cannot agree.

A State is never obliged by considerations of comity to surrender its legitimate interests in deference to another State’s policy choices. [***] The plaintiff acknowledges, as he must, that he and the decedent never entered a marriage. Nevertheless, he and amici maintain that the same considerations of comity must lead New York to recognize his Vermont civil union inasmuch as there is nothing to suggest that a civil union of same-sex individuals is abhorrent to the public policy of New York (*cf. Workers *102 Comp. Law § 4; Executive Law § 291[1] and [2]; Civil Rights Law § 40–c; 18 NYCRR 421.16 [h][2]; Matter of Jacob*, 86 N.Y.2d 651, 662; *Braschi v. Stahl Assoc.*, *supra*; *People v. Onofre*, 51 N.Y.2d 476, *cert. denied* 451 U.S. 987). But recognition of a civil status validly created outside of New York does not necessarily imply that this State will give effect to all of the legal incidents of that status conferred by the foreign jurisdiction that created it. Where those incidents conflict with New York law, our courts will generally decide whether to give them effect by looking to traditional choice-of-law principles. [***]

*103 The right to maintain an action for wrongful death is a legal incident of the status conferred by Vermont’s civil union law (*see* Vt. Stat. Ann., tit. 15, § 1204[e][2]). On the question of whether to give that incident effect here, I find it significant that there is no evidence that the plaintiff and the decedent had any contacts with Vermont beyond the fact that their civil union was solemnized there. [***] Vermont, therefore, has no legitimate interest in determining whether the plaintiff, a resident of New York, has the right to maintain a wrongful death action against a New York defendant in connection with the death of another resident of New York occurring in this State. Indeed, during virtually all of their lives together, the plaintiff and the decedent resided in New York, and it was in this State that the conduct complained of occurred and the decedent died. Under these circumstances, New York certainly has the most significant contacts with the case and, therefore, the stronger interest in applying the provisions of its own wrongful death law [cc] ([***] Accordingly, like the majority, I reject the contention that the doctrine of comity demands that the plaintiff be permitted to sue in New York for wrongful death.

²¹⁰ I note that, in any event, “the Full Faith and Credit Clause does not compel a state to substitute the statutes of other states for its own statutes dealing with a subject matter concerning which it is competent to legislate” (*Franchise Tax Bd. of California v. Hyatt*, 538 U.S. 488, 494, [citation and internal quotation marks omitted]) so long as the State has “a significant contact or significant aggregation of contacts, creating state interests, such that choice of its law is neither arbitrary nor fundamentally unfair” (*Allstate Ins. Co. v. Hague*, 449 U.S. 302, 312).

I turn, then, to the area of my disagreement with the majority’s resolution of the appeal.

When a statute affords different treatment to similarly-situated persons on the basis of a constitutionally cognizable characteristic, the disparity of treatment must, at the least, *104 bear some rational relationship to a legitimate governmental objective promoted by the statute. As the United States Supreme Court long ago explained:

“It is unnecessary to say that the ‘equal protection of the laws’ required by the Fourteenth Amendment does not prevent the states from resorting to classification for the purposes of legislation ... But the classification must be reasonable, not arbitrary, and must rest upon some ground of difference having a fair and substantial relation to the object of the legislation, so that all persons similarly circumstanced shall be treated alike” [c].

Stated otherwise, “[t]he Equal Protection Clause ... [denies] to States the power to legislate that different treatment be accorded to persons placed by a statute into different classes on the basis of criteria wholly unrelated to the objective of that statute” (*Reed v. Reed*, 404 U.S. 71, 75–76). The question to be addressed, therefore, is whether, considering the purpose and objective of the wrongful death statute, there is some ground of difference that rationally explains the different treatment the statute accords to spouses and partners in a Vermont civil union [c].

The purpose of the wrongful death statute is well-defined and firmly established. It is not intended to recompense the survivor for the loss of companionship or consortium, or for the pain and anguish that accompanies the wrongful and unexpected loss of a loved one. It is instead designed solely to make a culpable tortfeasor liable for fair and just compensation to those who, by reason of their relationship to the decedent, suffer economic injury as a result of the decedent’s death (*see* EPTL 5–4.3[a]). A person suffers economic injury in this context when the death deprives him or her of a reasonable expectation of future financial assistance or support from the decedent [cc].

The plaintiff argues that, with respect to that objective, the wrongful death statute classifies similarly-situated persons on the basis of their sexual orientation. Sexual orientation is a constitutionally cognizable characteristic, and therefore when legislation is challenged on the ground that it classifies and treats persons differently on the basis of sexual orientation, courts will “insist on knowing the relation between the classification *105 adopted and the object to be attained” (*Romer v. Evans*, 517 U.S. 620, 632). This was so even before the Supreme Court repudiated *Bowers v. Hardwick*, 478 U.S. 186, 106 S. Ct. 2841, which upheld statutes criminalizing homosexual sodomy—the very conduct some saw as defining the class (*see e.g. Padula v. Webster*, 822 F.2d 97, 103). It certainly is true after the Supreme Court expressly overruled *Bowers*, recognizing that it “demean[ed] the lives of homosexual persons ... was not correct when it was decided”, and ... “is not correct today” (*Lawrence v. Texas*, 539 U.S. 558, 575, 560).

As to whether the wrongful death statute classifies on the basis of sexual orientation, I recognize that, in 1998, the Appellate Division, First Department, concluded that it did not, rejecting an equal protection challenge to the statute brought by the surviving member of an informal same-sex relationship not sanctioned by any State [c]. The Court wrote:

“[T]he wrongful-death statute (EPTL 5–4.1), which, by its terms (EPTL 1–2.5, 4–1.1, 5–1.2), does not give individuals not married to the decedent (other than certain blood

relatives) a right to bring a wrongful-death action, operates without regard to sexual orientation, in that unmarried couples living together, whether heterosexual or homosexual, similarly lack the right to bring a wrongful-death action, and, as such, the statute does not discriminate against same-sex partners in spousal-type relationships” (*id.* at 370, 675 N.Y.S.2d 343; [c]).

Leaving aside the fact that opposite-sex couples who remain unmarried do so out of choice while same-sex couples have little choice but to remain unmarried, the classification here is not between unmarried opposite-sex couples who choose to live together in an informal arrangement, and unmarried same-sex couples who do the same. The classification at issue here is between couples who enter into a committed, formalized, and state-sanctioned relationship that requires state action to dissolve and, perhaps most important, makes each partner legally responsible for the financial support of the other. For opposite-sex couples, of course, the relationship is marriage, sanctioned and recognized by the State (*see e.g.* Domestic Relations Law § 14–a), requiring a divorce or annulment to dissolve (*see e.g.* Domestic Relations Law §§ 140 and 170), and obligating each spouse *106 to provide for the support of the other (*see e.g.* Family Court Act § 412; Social Services Law § 101[1]). And, as relevant here, the relationship for same-sex couples is the Vermont civil union, sanctioned and recognized by the State (*see* Vt. Stat. Ann., Tit. 15, § 1201), requiring a court proceeding to dissolve (*see* Vt. Stat. Ann., Tit. 15 § 1206), and obligating each party to provide for the support of the other (*see* Vt. Stat. Ann., Tit. 15 § 1204 [c]).[fn]

With respect to the objectives of the wrongful death statute, spouses and parties to a Vermont civil union stand in precisely the same position. Marriage creates a legal and enforceable obligation of mutual support (*see e.g.* Family Court Act § 412; Social Services Law § 101[1]), and therefore the death of one spouse causes economic injury to the other because it results in the loss of an expectancy of future support created and guaranteed by law. And, in exactly the same way, because the state-sanctioned Vermont civil union gives rise to a legal and enforceable obligation of mutual support (*see* Vt. Stat. Ann., tit. 15, § 1204[c]), the death of one party to the union causes economic injury to the survivor because it results in the loss of an expectancy of future *107 support also created and guaranteed by law. Because no statute or authoritative holding in New York now permits or recognizes a marriage except between opposite-sex couples, and because Vermont civil unions are open only to same-sex couples (*see* Vt. Stat. Ann., tit. 15, § 1202[2]), the operation here of New York’s wrongful death statute to authorize a party to a marriage to recover damages for the wrongful death of his or her spouse, but not to permit a party to a Vermont civil union to recover damages for the wrongful death of his or her partner, in effect, affords different treatment to similarly-situated persons on the basis of sexual orientation.

The question, then, is whether there is a rational relationship between that disparity of treatment and some legitimate governmental interest or purpose (*see Romer v. Evans, supra* at 631–32, 116 S.Ct. 1620; [cc]; *Matter of Cooper, supra* at 134, 592 N.Y.S.2d 797).²¹¹ Ordinarily, when constitutional challenges are raised against laws prohibiting same-sex marriage, or laws favoring legal marriages over committed relationships between persons of the same sex, those who defend the challenged provisions do so on the basis of the traditional, religious, cultural, and legal understanding that marriage is the union of one man and one woman, and is the preferred environment for procreation and child-

²¹¹ The right to equal protection as guaranteed by the New York State Constitution is co-extensive with its federal counterpart [c].

rearing [cc]. Indeed, our own Court has declared that “[t]he institution of marriage as a union of man and woman, uniquely involving the procreation and rearing of children within a *108 family, is as old as the book of Genesis” (*Matter of Cooper, supra* at 133, 592 N.Y.S.2d 797, quoting *Baker v. Nelson, supra* at 312, 191 N.W.2d 185, *appeal dismissed* 409 U.S. 810; *cf. Skinner v. Oklahoma ex rel Williamson*, 316 U.S. 535, 541). The issue, therefore, is whether New York’s interest in fostering traditional marriage, and in preferring it to any other relationship between unrelated adults, is in any conceivable way advanced or promoted by a law that authorizes a surviving spouse, but not a surviving member of a Vermont civil union, to sue for wrongful death. Two cases decided by the United States Supreme Court are instructive on this question, and both involve the right to sue for wrongful death.

In *Levy v. Louisiana*, 391 U.S. 68, the Supreme Court struck down a statute which, because it was construed to authorize only legitimate children to maintain an action for the wrongful death of a parent, precluded five illegitimate children from suing for the wrongful death of their mother. The Supreme Court wrote:

“Legitimacy or illegitimacy of birth has no relation to the nature of the wrong allegedly inflicted on the mother. These children, though illegitimate, were dependent on her; she cared for them and nurtured them; they were indeed hers in the biological and in the spiritual sense; in her death they suffered wrong in the sense that any dependent would” (*id.* at 72, 88 S. Ct. 1509).

And, in the companion case of *Glonn v. American Guar. & Liab. Ins. Co.*, 391 U.S. 73, the Supreme Court struck down the same statute insofar as it was construed to bar a mother from maintaining an action for the wrongful death of her illegitimate child killed in an automobile accident. Here the court pointedly observed:

“[W]e see no possible rational basis for assuming that if the natural mother is allowed recovery for the wrongful death of her illegitimate child, the cause of illegitimacy will be served. It would, indeed, be farfetched to assume that women have illegitimate children so that they can be compensated in damages for their death. A law which creates an open season on illegitimates in the area of automobile accidents gives a windfall to tortfeasors. But it hardly has a causal connection with the ‘sin,’ which *109 is, we are told, the historic reason for the creation of the disability” (*id.* at 75, 88 S. Ct. 1515 [citation omitted]).²¹²

I recognize that “equal protection is not a license for courts to judge the wisdom, fairness, or logic of legislative choices ... [and that, i]n areas of social and economic policy, a statutory classification that neither proceeds along suspect lines nor infringes fundamental constitutional rights must be upheld against equal protection challenge if there is any reasonably conceivable state of facts that could provide a rational basis for the classification” [cc]. But just as the Supreme Court could find no

²¹² In contrast, the Court did find a rational relationship between the classification and the statutory purpose when it considered a challenge to the constitutionality of Louisiana’s intestate succession statutes which barred even publicly-acknowledged illegitimate children from sharing equally with legitimate children in the estate of their father when he died without a will. The Court upheld the statutes, noting, *inter alia*, that they clearly had a rational basis “in view of Louisiana’s interest in promoting family life *and of directing the disposition of property left within the State*” (*Labine v. Vincent*, 401 U.S. 532, 536 n. 6; *emphasis supplied*; but see *Trimble v. Gordon*, 430 U.S. 762, 97 S.Ct. 1459, 52 L.Ed.2d 31 [striking down, on equal protection grounds, a provision of Illinois’ Probate Act which allowed illegitimate children to inherit by intestate succession only from their mother]).

conceivable rational relationship between any governmental purpose promoted by a wrongful death law and a classification of wrongful death plaintiffs or victims according to their legitimacy, neither can I identify any reasonably conceivable rational basis for classifying similarly-situated wrongful death plaintiffs on the basis of their sexual orientation.

Stated otherwise, I simply cannot reasonably conceive of any way in which New York's interest in fostering and promoting traditional marriage is furthered by a law that determines, based on a person's sexual orientation, whether he or she may have access to our courts to seek compensation for the loss of a pecuniary expectancy created and guaranteed by law [c]. *110 And, tellingly, the majority's rejection of the equal protection claim does not include any hint or suggestion of how preventing the plaintiff from asserting a wrongful death claim promotes the State's interest in fostering the institution of marriage, "thus leaving [its] constitutional analysis incomplete" [c]. Indeed, the only real effect of the majority's position is to provide a windfall to a potential tortfeasor.

Accordingly, I respectfully dissent and would hold that the application of New York's wrongful death statute to deny the right of a surviving member of a Vermont civil union to maintain an action to recover damages for the wrongful death of his or her partner is inconsistent with the right to equal protection of the laws. I would further hold that the proper remedy is to extend the benefit of EPTL 5-4.1 to include the plaintiff as a surviving member of a Vermont civil union (*see People v. Liberta*, 64 N.Y.2d 152, 170, *cert. denied* 471 U.S. 1020; *see also Califano v. Westcott*, 443 U.S. 76, 89-90). In my judgment, therefore, the order appealed from should be affirmed insofar as appealed from.

ORDERED that the order is reversed insofar as appealed from, on the law, without costs or disbursements, that branch of the motion which was to dismiss the cause of action to recover damages for wrongful death is granted, the cross motion is denied, and the cause of action to recover damages for wrongful death is dismissed.

Note 1. The court cites an **institutional competence** rationale partially to explain its ruling ("Unlike the court, which can only rule on the issues before it, the Legislature is empowered to act on all facets of the issue including but not limited to, the issues of the solemnization and creation of such relationships, the dissolution of such relationships and the consequences attendant thereto, and all other rights and liabilities that flow from such a relationship" (at p. *95)). How does the dissent come out on this issue? What is the dissent urging?

Note 2. The dissent's efforts to frame the issue did not convince the remaining members of the court, but they are worth our attention: "What this case is about is the operation of a single statute—New York's wrongful death statute—that controls access to the courts for those seeking compensation for the loss of a pecuniary expectancy created and guaranteed by law." Insisting on one technical definition of "spouse" in this context follows a formalistic understanding of law; broadening it to align with the plaintiff's real-life circumstances would serve a more functionalist vision of law. Setting aside the very important equal protection issues—since *Obergefell v. Hodges*, 576 U.S. 644 (2015) appears to have resolved those for subsequent cases on this issue—which understanding of "spouse" is more persuasive to you and why?

Recently, the Supreme Court overturned *Roe v. Wade* in *Dobbs v. Jackson Women's Health Organization*, No. 19-1392, 597 U.S. ____ (2022). Because the right to abortion had been understood as originating in a fundamental right to privacy on which a line of other cases likewise relied, commentators have wondered whether *Obergefell* and other protections for same-sex couples could be

endangered. Several justices have stated that *Dobbs* does not imperil existing protections relevant for the LGBTQ community, notwithstanding its concurrence by Justice Thomas, in which he calls for reconsidering all precedents based on the Court's substantive due process jurisprudence, including *Obergefell* (Slip Op. at 3). Judicial, executive and legislative changes on the horizon seem likely. Consider which entity you believe most appropriate to shape policy on these significant issues, and why. Does your answer depend on the issue's political salience or do you hold the same beliefs about institutional competence with respect to other areas you have studied in tort law?

MODULE 7. DEFAMATION

Chapter 36. Introduction to Defamation's Elements at Common Law (Until 1964)

Defamation is a distinctly different sort of legal claim from those covered in the course so far. It is in some key respects a hybrid tort. It usually requires *some intent*, making it at least partly an intentional tort insofar as the elements include (1) **a defamatory statement** (2) **about the plaintiff** (3) intentionally made (or “**published**”) to a third party, (4) **without privilege** or authorization to do so, that (5) caused “**special damages**” (which are pecuniary losses) *or* falls into a category of enumerated kinds of communications whose for which such **damages may be presumed**.

Yet contemporary defamation has become something of a hybrid tort. In some instances, such as when speaking about a private figure on a private matter, intent may not be needed and mere negligence may be deemed sufficient to allow recovery. Contemporary defamation's culpability standard reflects the possible range from a minimum of fault amounting to at least negligence on the part of the publisher to a special standard you will learn about, known as “actual malice.” However, at common law, defamation was a strict liability tort, so the plaintiff was not required to prove fault merely to make out a claim.

It is important to learn the elements of defamation at common law because they shape pleading requirements and various defenses. However, it is equally important to understand at the outset that you will be learning about significant changes that have produced our contemporary defamation laws. For instance, until 1964, states were free to allow plaintiffs to bring defamation claims in strict liability; after that time, they were forbidden from doing so. In an unprecedented move, the Supreme Court handed down a landmark decision that year and thus launched an era of several decades of “constitutionalizing” state defamation law.

One reason for the complexity associated with studying defamation law is that it varies a great deal by state and the common law rules are arcane and technical. Yet another is the need to understand the law before and after its constitutionalization. Defamation cases are compelling, however, both legally and culturally, and they make efforts to learn the relevant law well worth it.

Defamation's Elements at Common Law, A Deeper Dive

(1) A defamatory statement. The first element at common law is a defamatory statement. Historically, there was some variety regarding whether the burden was initially on the plaintiff to prove falsity (which is the modern trend) or whether it was up to the defendant to prove the truth of the communications as an affirmative defense. However at common law most jurisdictions, permitted the plaintiff to presume falsity (at least until 1964). This meant that the initial burden of proving truth or falsity was placed on the defendant rather than the plaintiff. That burden allocation reflected great solicitude for the reputational interests protected by the tort of defamation and a correspondingly lower protection for speech.

The standards and process for how to determine a statement's defamatory potential meaning and impact were largely the same at common law as they are today even if the terminology has been modernized in some jurisdictions to some extent. Whether a statement was *potentially* defamatory is a

question of law for the court. Whether it was indeed defamatory in its reception by others is a question for the jury, however. A statement is defamatory if it can be understood as an untrue communication that subjects the plaintiff to scorn or ridicule in the eyes of others. In evaluating any allegedly defamatory statement, the test is the effect it is “fairly calculated to produce, the impression it would naturally engender, in the minds of the average persons among whom it is intended to circulate.” *Corabi v. Curtis Publishing Company*, 441 Pa. 432, 447 (1971). Opinions, even when negative, are usually protected from defamation claims. In order for an opinion to be actionable, the “allegedly libeled party must demonstrate that the communicated opinion may reasonably be understood to imply the existence of undisclosed defamatory facts justifying the opinion.” *Beckman v. Dunn*, 276 Pa. Super. at 535, 419 A.2d at 587, citing Restatement (Second) Torts, Section 566 (1976). Mere statements of opinion that do not imply facts are not actionable. Defamation is a tort that protects against the reputational harm caused by allegations of false *facts* not simply unflattering opinions.

- **Statements defamatory on their face:** Some statements are very obviously defamatory and clearly identify the plaintiff. In such cases, at common law the plaintiff needed only to prove that the defamation was published to a third party without privilege and that this publication had either caused them pecuniary loss (“special damages”) or fell into a category that permitted the plaintiff to presume damages.
- **Statements not defamatory on their face:** However, if a statement’s meaning was unclear or not clearly about the plaintiff, the plaintiff faced additional pleading requirements. In a special part of the pleading known as the **inducement**, the plaintiff was required to offer extrinsic evidence and support for their theory of why the statement was defamatory and referring to them. The **innuendo** was the plaintiff’s explanation of how the statement was to be understood as defamatory.

(2) **About the plaintiff.** The statement must be “**of and concerning**” the plaintiff. This is still sometimes referred to as the **colloquium** requirement. In many cases, the defamatory statement clearly identifies the plaintiff, but if there is doubt on this question, or if the statement could plausibly be made to refer to many different possible people, the plaintiff must prove that it referred to them.

(3) **Made to a third party, or “publication.”** The tort of defamation is not designed to protect against hurt feelings but rather to guard against the loss of standing in the minds of people *other than* the plaintiff. Consequently, defamation requires that at least one third party have heard or seen the allegedly defamatory content. This is known as the “**publication**” requirement. A defamatory statement need not be “published” in the lay sense that describes a book or magazine’s publication, or even a website’s being posted or updated. For instance, an oral communication may be a publication. What matters is that it be **an intentional communication to a third party**.

(4) Publication must have been made **without a justification or privilege**. A privilege may be conditional or absolute, rather like the forms of immunity described in Module 4. An **absolute privilege** extends, for instance, to judicial proceedings and there can be no defamation claim pertaining to statements made about the parties in connection with a lawsuit, so long as the matters discussed are pertinent to the lawsuit. In suing a physician for medical malpractice, for instance, it would not be relevant to make allegations that they were an adulterer, unfriendly neighbor, or irreligious person, for instance (unless something about those characteristics caused the malpractice). Going off topic exceeds the scope of the privilege. A **conditional** (or “**qualified**”) **privilege** arises in particular contexts based on the idea that some interests could be harmed or limited if people did not speak due to fear of

defamation liability. For instance, qualified privileges shield from liability hiring conversations between a potential and former employer. Similarly, such privileges protect admissions processes through which entities may provide references or letters of recommendation for a prospect. These parties can discuss the prospective employee's or student's record and performance without fear of a defamation suit's succeeding, even if they share negative impressions of the applicant. Generally, such conversations are protected based on a theory that they are **based on a mutual interest** in the need for accurate informational exchange. (You will learn more about defenses and privileges below, but it is important to understand that a successful defamation claim requires that the publication of the statement not be privileged. You can think of this as somewhat analogous to the way that defeating "consent" can play a role in the plaintiff's making out a prima facie case when pleading battery.)

(5) Caused "special damages" or qualifies for presumed damages. In a significant number of defamation scenarios at common law, harm could be presumed. This possibility has become much more limited with the constitutionalization of defamation law. However, at common law, there were two major categories of communications in which harm could be presumed: **libel** or **slander per se**. If a plaintiff could make out a claim for libel or slander per se, the plaintiff benefited from being able to presume harm rather than proving it up. By contrast, when claiming only slander (a broader category than slander per se), the plaintiff needed to prove special damages (that is, economic losses caused by the alleged defamation). This was (and is) a notoriously difficult burden to meet, which is why the presumption was traditionally allowed. Permission to presume such harm has been sharply limited in our era due to rulings by the Supreme Court's holding that constitutional obligations to protect free speech take precedence over reputational interests in a number of scenarios.

Another way of putting this is that there is a special category of statements treated as so presumptively harmful that they are considered **defamation per se**, and they permit a party to presume damages under certain conditions. Conceptually, this may remind you of some of the intentional torts, such as battery, trespass and conversion. Recall that with those three torts, merely proving the elements permits the plaintiff not to have to prove they have suffered harm. Showing that a protected interest has been invaded effectively allows the plaintiff to presume the harm. Damages awarded in connection with those earlier intentional torts may be low or nominal in such cases, depending on the facts at hand. But the cases won't fail for lack of ability to prove harm. Defamation features a similar potential benefit, at least *in per se cases*, when other conditions are met.

Exam Tip: Remember, Defamation Vindicates Reputational Loss, Not Hurt Feelings.

Defamation is the tort that protects individuals' reputations. The measure of injury isn't whether the plaintiff thinks their reputation could suffer but whether the reputation actually has suffered, or could have suffered, in the minds of others. It is not intended to vindicate mere hurt feelings (though it often accompanies hurt feelings, emotional distress, and claims for IIED and/or invasion of privacy). For this reason, allegedly defamatory communications must have been made to a party other than the plaintiff, which is known as the "publication" requirement, and they must convey meanings about the plaintiff that are not merely negative but also false.

Federal Credit, Inc. v. Greg Fuller, Supreme Court of Alabama (2011) (72 So.3d 5)

[***] On September 14, 2001, Federal Credit and Fuller entered into a “Deferred Presentment Service Agreement” (“the contract”), under which Fuller borrowed \$1,000 from Federal Credit. Pursuant to the contract, Fuller provided Federal Credit with two checks in the amount of *7 \$500 each, plus one check in the amount of \$300 for a “service fee”; under the terms of the contract, Federal Credit agreed to hold Fuller’s checks until the “presentment date,” i.e., the date payment was due under the contract, October 5, 2001. Fuller, however, failed to pay the amount due under the contract on or before the presentment date. Shortly thereafter, Federal Credit presented Fuller’s checks to the bank on which the checks were drawn; the bank returned each of Fuller’s checks to Federal Credit stamped “account closed” and “payment stopped.”

On October 8, 2001, Federal Credit mailed Fuller a document styled as a “10 Day Legal Notice” (“the notice”); Federal Credit addressed the envelope containing the notice to Fuller’s employer, Charter Communications (“Charter”), with “Mr. Fuller” handwritten in significantly smaller letters immediately below “Charter Communications.”²¹³ When the notice arrived at Charter, three or four other employees of Charter, including Fuller’s boss, Tom Salters, viewed the notice before Fuller was called into Salters’s office and presented with the notice.²¹⁴ The notice stated:

“This statutory notice is provided pursuant to Section 13A–9–13[.]2 of the Code of Alabama. [fn] You are hereby notified that a check, apparently issued by you, has been dishonored. Pursuant to Alabama Law, *you have ten (10) days from receipt of this notice to render payment* of the full amount of such check or instrument plus service charges, *the total amount due being \$1573.00*. Unless this amount is paid in full within the specified time above, the holder of such check or instrument may assume that *you delivered the instrument with intent of [sic] defraud* and may turn over the dishonored check and all other available *8 information relating to this incident to the proper authorities for criminal and/or civil prosecution. A photocopy of your bad check which will be part of the evidence presented against you should this matter be transferred to the proper authorities, is attached for your review. This company utilizes the services of the **District Attorney Worthless Check Unit and District Court System.**”

(Boldface type and emphasis in original.) Copies of Fuller’s two checks for \$500 and one check for \$300 appeared at the bottom of the notice. Federal Credit had “stamped” the notice numerous times, including as follows: “DISTRICT COURT FILE EVIDENCE DATA BASE FILE # 8802 ds” next to

²¹³ In the contract, Fuller provided Federal Credit with both his home address and the name and telephone number of his employer, Charter. Atha Ellis, an employee of Federal Credit, testified that Federal Credit attempted to send the notice to Fuller at his home address by certified mail; however, Ellis testified, the certified letter was either “refused” or “not claimed” by Fuller.

²¹⁴ We note that, with regard to Federal Credit’s mailing of the notice to Fuller at his place of employment, the contract provided: “You [Fuller] agree to the release, disclosure and use of any information contained herein and in the ... information form including but not limited to *account/contract status ... to whomever deemed necessary by us.*” (Emphasis added.)

each check; and “APPROVED OCT 8 2001 FOR PICKUP TO ALABAMA DISTRICT COURT AUTHORIZATION CODE: 8805–d.s.” (Capitalization in original.)

On October 10, 2001, Federal Credit filed a statement of claim in the small-claims division of the Marshall District Court, seeking a judgment in the amount of \$1,573, plus court costs. On December 17, 2001, the district court entered the following notation on the case-action-summary sheet: “[Fuller] enters consent judgment for \$1500.00 plus cost[s] for the purpose of appeal to circuit court to file counter-claim in excess of jurisdictional amount of small claims court.” On the same day, Fuller appealed to the Marshall Circuit Court.

In August 2002, Fuller filed in the circuit court a counterclaim against Federal Credit, seeking compensatory damages in the amount of \$50,000 and punitive damages in the amount of \$5,000,000 on claims alleging defamation and “violation of the [Alabama] Small Loan[] Act and usury.” The case was tried before a jury beginning on April 12, 2006. At the close of Fuller’s case-in-chief, Federal Credit orally moved the circuit court for a “directed verdict,” [fn] arguing, in sum, that Fuller had failed to prove the elements of either defamation or usury; the circuit court partially granted Federal Credit’s motion, dismissing Fuller’s usury claim.

On April 13, 2006, the jury returned a verdict in favor of Fuller on Fuller’s defamation claim, awarding Fuller compensatory damages in the amount of \$25,000 and punitive damages in the amount of \$35,000.²¹⁵ On May 12, 2006, Federal Credit filed a motion for a new trial; a motion for remittitur; and a “renewal motion for a judgment as a matter of law.” In the last of those motions, Federal Credit argued that it was entitled to a judgment as a matter of law because, it said:

“Greg Fuller alleges that a letter being sent to him via his employer seeking repayment of a debt defamed him. Although indebtedness may be defamatory, the fact that he owed Federal Credit ... was absolutely true. Truth is an absolute defense to defamation.
[c]

“All statements in the communication were true. The letter states that Federal Credit ... utilized the services of the District Court System to collect on unpaid accounts. This statement is true and is not defamatory. In fact, Federal Credit ... did just that by initiating this *9 cause of action. The letter states that Federal Credit ... utilizes the services of the District Attorney Worthless Check Unit. This also is true. This statement recites company policy and does not defame Greg Fuller. Pursuant to Alabama law, a District Attorney can be utilized to collect on deferred presentments wherein the account has been closed or no account is in existence. [***] These statements do not defame Greg Fuller.”
[***]

“To establish a prima facie case of defamation, a plaintiff must show:

“ [1] that the defendant was at least negligent [2] in publishing [3] a *false* and defamatory statement to another [4] concerning the plaintiff, [5] which is either actionable without having to prove special harm (actionable per se) *10 or

²¹⁵ The record on appeal reveals that Fuller consented to the entry of a judgment against him in the circuit court in the amount of \$1,500. (“The nominal defendant [Fuller] has consented to judgment in the amount of \$1,500.”).

actionable upon allegations and proof of special harm (actionable per quod).’ ”
[cc]

Truth is a “complete and absolute defense” to defamation. [cc] Truthful statements cannot, as a matter of law, have a defamatory meaning. [***]

In his counterclaim, Fuller contended that the following statements set forth in the notice were false: (1) “[T]hat [Fuller] delivered the instrument with intent of [sic] defraud.” (emphasis in original); (2) that “[t]his company [Federal Credit] utilizes the services of the **District Attorney Worthless Check Unit and District Court System.**” (Boldface type and emphasis in original.)

There was a paucity of evidence presented at trial regarding Federal Credit’s allegedly defamatory statements. Regarding Fuller’s allegation that Federal Credit defamed him by stating in the notice that Fuller had “delivered the instrument with intent of [sic] defraud,” the only evidence Fuller presented at trial was his testimony that he did not “write those checks with the intent to defraud anyone.”

The notice does not specifically state that Fuller delivered the checks to Federal Credit with the intent to defraud Federal Credit; rather, the notice states, in relevant part: “Unless this amount is paid in full within the specified time above, the holder of such check or instrument may assume that [Fuller] delivered the instrument with intent of [sic] defraud and may *11 turn over the dishonored check ... to the proper authorities for criminal and/or civil prosecution.” (Original emphasis omitted.) Considering the above-quoted statement in its entirety (rather than, as Fuller has done, considering only a selective part of the statement), it is clear that the statement was not an allegation that Fuller intended to defraud Federal Credit when he wrote the checks, but was instead simply a notification to Fuller of the potential consequences if he failed to pay the amount due under the contract. Although Fuller and the other employees of Charter who saw the notice might have mistakenly *construed* the statement as accusing Fuller of intentionally defrauding Federal Credit, the statement was not false and, therefore, is not actionable.²¹⁶ [***]

In view of the evidence in the record, we conclude that Fuller failed to meet his burden of making a prima facie showing that false information was reported in the notice seen by other employees of Charter; thus, Federal Credit was entitled to a judgment as a matter of law on Fuller’s defamation claim. *See Liberty Loan Corp. of Gadsden v. Mizell*, 410 So.2d 45, 49 (Ala.1982) (reversing the trial court’s judgment in favor of the plaintiff and directing the entry of a judgment for the defendant, concluding, in part, that a truthful statement indicating that the plaintiff owed a debt to the defendant and had refused to *12 pay the debt was not defamatory). Accordingly, the circuit court’s judgment in favor of Fuller is due to be reversed and a judgment rendered for Federal Credit on Fuller’s claim against it. [***] For the reasons discussed above, we reverse the circuit court’s judgment and render a judgment for Federal Credit.

Note 1. What was Fuller claiming were the defamatory communications about him? Why did the court reject his theory?

Note 2. What had Fuller done, regarding the payments towards the debt he owed?

²¹⁶ Furthermore, we note that Fuller admitted at trial that he did not pay the amount due under the contract in a timely manner.

Note 3. Does the court find that the “publication” requirement had been met?

Check Your Understanding (7-1)

Question 1. True or False: Defamation at common law always required that the plaintiff prove special damages.

An interactive H5P element has been excluded from this version of the text. You can view it online here: <https://saidtorts2d.lawbooks.cali.org/?p=102#h5p-126>

Question 2. In *Fuller*, the most important factor in the plaintiff’s failure to recover for defamation was likely:

An interactive H5P element has been excluded from this version of the text. You can view it online here: <https://saidtorts2d.lawbooks.cali.org/?p=102#h5p-127>

Heightened Pleading Requirements at Common Law. Defamation possessed that same “checklist” quality of the early intentional torts reflecting their common origin in the writ system. In fact, defamation was historically subject to **extremely strict pleading requirements**, perhaps even to a greater extent than the other intentional torts you learned about in Module 2. It was a benefit to the plaintiff to forgo having to plead any fault (because recall that defamation was historically a strict liability tort). Yet if the plaintiff erred or omitted any of the arcane and technical requirements in their pleading, the claim would fail. Truth was a defense at common law although in many jurisdictions, even a minor, trivial mistake could defeat the defense of truth. Indeed, the default rule regarding defamation suits tended to protect reputational interests over those of speakers and publishers. Put another way, the burdens were heavier for defendants than for plaintiffs, and this was so by design.

Lower Substantive Requirements for Plaintiffs at Common Law. Whether the communications were true was, at common law before 1964, less important in the first instance than the fact that they had been uttered: if the plaintiff could prove this, and the defamatory meaning was clear, then the plaintiff won *unless the defendant could prove the statements were true*. In the contemporary era, plaintiffs usually bear the burden of proving falsity, in addition to making clear the defamatory aspects of the communication. The plaintiff usually loses if they cannot prove falsity. This shift in the burden from defendant (proving truth) to plaintiff (proving falsity) reflected profound changes in the view of the tort of defamation. Can you see why it mattered?

In addition, although at common law defamation was a strict liability tort, contemporary defamation law now requires proof of culpability in nearly all instances. This is either because of constitutional constraints that the Supreme Court articulated and expanded on or because state courts and legislatures have opted to include a minimum fault level, “at least negligence,” which can vary according to multiple factors you will learn about over the course of this Module.

Defamation's variable culpability standard is likely the most difficult aspect to understand for those learning contemporary defamation law. The culpability the plaintiff will need to prove is largely determined by the identity of the plaintiff, but it may also be affected to some extent by the general topic of the communication as well as the identity of the speaker (since in at least a few jurisdictions, media defendants are held to slightly different rules, and may avail themselves of slightly different defenses). Understanding the variety that constitutes the culpability requirement necessitates familiarity with case law you have yet to learn, but it is impossible to summarize contemporary defamation law responsibly without addressing the variable culpability standard. This variability is due to the sweeping changes made to state tort law by the Supreme Court as you read about *supra* under the Introduction to Defamation's Elements at Common Law.

Be patient as you learn the common law rules and be ready to layer on further complexity when learning about the constitutional limits of state defamation law. The interplay between state and constitutional rules provides a valuable introduction to dynamics you will explore in depth when you take a class in constitutional law. It will also represent a significant departure from the kind of cases and the reasoning with which you have become familiar in tort law thus far. The main takeaways at this point are that common law imposed arcane, technical and rigid pleading requirements on plaintiffs and those have relaxed to some extent. However, it afforded plaintiffs significant leeway in not requiring that they prove falsity or fault and in permitting them to presume rather than prove damages in a much broader category of cases than now available.

In sum, historically the law protected reputational interests more liberally and safeguarded speech intents correspondingly less. That balance has changed in the modern era.

Categories of Defamation: Diverse Forms of Libel and Slander

Libel Per Se versus Libel Per Quod. In *Fuller*, the court refers to a statement's being "actionable per quod." If an action is not "per se defamatory," it may be treated as "per quod defamatory," meaning that the communications do not clearly indicate how or why they are defamatory. The general rule is that per quod defamatory communications require proof, perhaps via extrinsic evidence, of the defamatory nature of the communications; per se defamatory communications are thought to speak for themselves.

Libel versus Slander (and Slander Per Se). There are two main types of defamation: **libel and slander**. Historically, libel referred to defamation that occurred in print and slander referred to oral communications (of which slander per se represents a special subset). In everyday conversation, many people use the terms "libel law" and "defamation law" interchangeably but lawyers do need to know that libel, technically, is just one kind of defamation.

Libel was historically a stronger tort and allowed plaintiffs to presume damages. The rationales for this distinction were somewhat haphazard yet the distinction has proven persistent nonetheless. ("As a result of historical accident, which, though not sensibly defensible today, is so well settled as to be beyond our ability to uproot it [c], there is a schism between the law governing slander and the law governing libel (see Restatement, Torts 2d, § 568, comment b)."*Matherson v. Marchello*, 100 A.D.2d 233, 235 (1984)). One oft-cited rationale for distinguishing libel from slander is that defamatory statements made in print may be more robust in their duration and reach, and thus likelier than oral communications to cause enduring harm. Some commenters have categorized libel as defamation that

is “visual” (whether communications are made in printed text or images). However, libel has been broadened beyond the merely visual to include dissemination by audio broadcasting and now includes also audiovisual broadcasts. It is a matter of state law whether statements and images disseminated over the internet (or via Twitter and other such platforms) constitutes libel or slander, but the majority trend is to treat such communications as libel.

Slander, by contrast, required proof of special damages (pecuniary loss), in addition to proving that someone had said something defamatory about the plaintiff, which could be difficult given that oral communications are often not recorded and may not have been made in front of the plaintiff. Various states have adopted different formulations of the elements though there is considerable overlap. In New York, which provides a representative example, the elements of slander are:

- (1) a defamatory statement of fact
- (2) that is false
- (3) published to a third party
- (4) of and concerning the plaintiff
- (5) made with the applicable level of fault on the speaker’s part
- (6) either causing special damages or constituting slander per se
- (7) and not privileged.

Germain v. M & T Bank Corp., 111 F. Supp.3d 506, 534 (S.D.N.Y.2015). These elements are sometimes collapsed into four inquiries: a “false statement, published without privilege or authorization to a third party, constituting fault as judged by, at a minimum, a negligence standard, and it must either cause special harm or constitute defamation per se.” *Salvatore v. Kumar*, 45 A.D.3d 560, 563 (2007)

Either way, both recitations of elements make clear that the culpability level can vary, as does the need to prove special harm. This is because a subset of slanderous communications, however, were categorized as “per se”—following the reasoning provided *supra* regarding “per se” versus “per quod” communications discussed above.

Slander Per Se. Many jurisdictions follow the common law rule of treating “slander per se” as though it were libel, meaning that damages may be presumed rather than needing to be proven. However, in the modern era, the availability of presumed damages has been restricted, as you will learn later in this module. Slander per se communications fall into one of four categories at common law.

Restatement Second of Torts § 570 (1977) Liability Without Proof of Special Harm—Slander

One who publishes matter defamatory to another in such a manner as to make the publication a slander is subject to liability to the other although no special harm results if the publication imputes to the other

- (a) a criminal offense, as stated in § 571, or
- (b) a loathsome disease, as stated in § 572, or
- (c) matter incompatible with his business, trade, profession, or office, as stated in § 573, or
- (d) serious sexual misconduct, as stated in § 574.

To qualify as slander per se, communications falsely suggesting someone was involved with or had committed a “criminal offense” required the imputation of a serious or “major” crime. Hinting at minor

criminality did not suffice to convert an allegedly defamatory oral statement into slander per se. Similarly, a loathsome disease had to be bad enough that it was likely to cause social exclusion or to make pecuniary loss foreseeable. Modern examples include herpes and AIDS (and one might imagine Monkeypox could be added to the list). The imputation of professional misconduct is often glossed as incompetence, negligence or misdealing. “Serious sexual misconduct” was very much a product of its times. In the earliest cases, it was used to permit recovery without proof of special harm in cases in which a woman was called unchaste, or for false allegations of adultery or homosexuality.

These default categorizations presume that a person might find it so intolerable to be falsely characterized as something other than straight that it is legally actionable without any proof of financial losses caused by the alleged defamation. Let’s be clear: for purposes of defamation law, courts treated being gay as functionally equivalent to being infectious, criminal or incompetent. This equivalence provides an example of how tort law can signal its values by protecting one set of interests at the expense of another set; tort law’s slander per se categories effectively endorse a form of deep homophobia in their solicitude for reputational interests. Some earlier courts had recognized the harmful message conveyed by judicial approbation of a doctrine that categorized homosexuality as functionally equivalent to offensive disease, major criminality and professional wrongdoing or incompetence. Yet unfortunately sometimes changes in the common law proceed slowly and may produce a jarring misalignment with cultural practice or values. Thus the slander (and defamation) per se rules in many jurisdictions still treat homosexuality under the older, homophobic approach. As the next case reveals, it was only in 2020 that socially progressive New York state formally stopped categorizing misstatements regarding sexual orientation as slander per se.

**Laguerre v. Maurice, Supreme Court, Appellate Division, Second Dept., New York (2020)
(192 A.D.3d 44)**

46** In this action, inter alia, to recover damages for defamation per se, the plaintiff alleges that he was defamed by the pastor of the defendant church when the pastor told members of the congregation that the plaintiff was a homosexual who viewed gay pornography on the church’s computer. [] [At issue is] whether the false imputation that a person is a homosexual constitutes defamation per se. For the reasons that follow, we answer both of these questions in the negative.

The plaintiff is a former elder in the Gethsemane SDA Church (hereinafter the church). The defendant Pastor Jean Renald Maurice is the pastor in charge of the church, which allegedly is operated by the defendant The Greater New York Corporation of Seventh Day Adventist. In September 2017, the plaintiff commenced this action against the defendants, inter alia, to recover damages for defamation per se. As set forth in the complaint, Pastor Maurice stated before approximately 300 members of the church that “the [p]laintiff was a homosexual,” and that “the [p]laintiff disrespected the church by viewing gay pornography on the church’s computer.” The complaint alleged that these statements constituted defamation per se, inasmuch as they falsely portrayed the plaintiff “as a homosexual man with no self-control who uses the church’s computer to view gay porn.” The complaint further alleged that Pastor Maurice used these statements to influence the church to vote to relieve the plaintiff of his responsibilities at the church and to terminate his membership.

*47 The [***] defendants argued that the complaint failed to state a cause of action to recover damages for defamation per se, since falsely ascribing homosexuality to a person no longer constituted defamation per se, and the plaintiff had failed to allege that he sustained any special damages. [***] [T]he court determined that the plaintiff had sufficiently stated a claim to recover damages for defamation per se. The defendants appeal.

[T]he Supreme Court erred in determining that the complaint sufficiently stated a cause of action to recover damages for defamation per se. [***] Here, the plaintiff, citing *Matherson v. Marchello*, 100 A.D.2d 233, and *Klepetko v. Reisman*, 41 A.D.3d 551, contends that the Second Department has previously recognized that the false imputation of homosexuality constitutes defamation per se.

In 1984, this Court decided *Matherson v. Marchello*, 100 A.D.2d 233. In *Matherson*, the plaintiffs, husband and wife, commenced an action to recover damages for defamation based upon certain statements made during a radio interview by the defendants, members of a singing group. The plaintiffs alleged, in pertinent part, that the statement directed at the plaintiff husband—“I think it was when somebody started messing around with his boyfriend that he really freaked out”—constituted an imputation of homosexuality which should be recognized as defamatory (*id.* at 241). This Court noted that “[i]t cannot be said that social opprobrium of homosexuality does not remain with us today,” and that “[r]ightly or wrongly, many individuals still view homosexuality as immoral” (*id.*). Additionally, we observed that “[l]egal sanctions imposed upon homosexuals in areas ranging from immigration to military service [had] recently been reaffirmed” (*id.* [citations omitted]). Thus, we concluded that “the potential and probable harm of a false charge of homosexuality, in terms of social and economic impact, cannot be ignored,” and “that the imputation of homosexuality is reasonably susceptible of a defamatory connotation ... and is actionable without proof of special damages” (*id.* at 242 [internal quotation marks and citation omitted]).

In *Klepetko v. Reisman*, 41 A.D.3d 551, which was decided in 2007, the plaintiff commenced an action to recover damages for allegedly defamatory statements made in a column in a daily newspaper. The plaintiff challenged, among other remarks, the statement that he “lived with another middle-aged man,” which the plaintiff alleged was “an insinuation that he is a homosexual” (*id.* at 551). This Court, quoting *Matherson*, stated that “[t]he false imputation of homosexuality is ‘reasonably susceptible of a defamatory connotation’ ” (*id.* at 552, quoting *Matherson v. Marchello*, 100 A.D.2d at 242). Ultimately, however, this Court held that “the statement that *52 the plaintiff lived together with another middle-aged man [did] not readily connote a sexual relationship, particularly when viewed in the context of a column concerning irresponsible dog owners” (*Klepetko v. Reisman*, 41 A.D.3d at 552).

As noted by the Third Department, the Appellate Division in all four Departments had recognized statements falsely imputing homosexuality as a category of defamation per se (*see Yonaty v. Mincolla*, 97 A.D.3d 141, 144, citing *Klepetko v. Reisman*, 41 A.D.3d at 552, [c], [c], *Matherson v. Marchello*, 100 A.D.2d at 241–242, and [c]).

In *Yonaty*, which was decided in 2012, the Third Department held that these Appellate Division decisions were “inconsistent with current public policy and should no longer be followed” (*Yonaty v. Mincolla*, 97 A.D.3d at 144). The court determined that “the prior cases categorizing statements that falsely impute homosexuality as defamatory per se [were] based upon the flawed premise that it is shameful and disgraceful to be described as lesbian, gay or bisexual,” and that “such a rule necessarily

equates individuals who are lesbian, gay or bisexual with those who have committed a ‘serious crime’—one of the four established per se categories.” The Third Department rejected this Court’s holding in *Matherson*. The court reasoned that “[i]n light of the tremendous evolution in social attitudes regarding homosexuality, the elimination of the legal sanctions that troubled the Second Department in 1984 and the considerable legal protection and respect that the law of this state now accords lesbians, gays and bisexuals, it cannot be said that current public opinion supports a rule that would equate statements imputing homosexuality with accusations of serious criminal conduct or insinuations that an individual has a loathsome disease” (*id.* at 146, 945 N.Y.S.2d 774).

We agree with our colleagues in the Third Department that the earlier cases, including this Court’s decision in *Matherson*, which held that the false imputation of homosexuality constitutes a category of defamation per se, are inconsistent with current public policy. This profound and notable transformation of cultural attitudes and governmental protective laws impacts our own consideration of stare decisis. Indeed, as *53 recognized by the United States District Court for the Southern District of New York in 2009, the decades since *Matherson* “have seen a veritable sea change in social attitudes about homosexuality,” including the decision of the United States Supreme Court in 2003, in which the Court invalidated laws criminalizing intimate homosexual conduct as violative of the Fourteenth Amendment’s Due Process Clause (*Stern v. Cosby*, 645 F. Supp. 2d 258, 273–274 [S.D. N.Y.], citing *Lawrence v. Texas*, 539 U.S. 558, 578). More recently, in 2015, the United States Supreme Court recognized the fundamental right of same-sex couples to marry in all states (*see Obergefell v. Hodges*, 576 U.S. 644, 675).

Notably, in New York, “the Human Rights Law, since 2002, has expressly prohibited discrimination based on sexual orientation in employment, public accommodations, credit, education and housing” (*Yonaty v. Mincolla*, 97 A.D.3d at 145, citing Executive Law § 296). Moreover, marriage between persons of the same sex was permitted in New York years before the United States Supreme Court’s decision in *Obergefell* (*see Matter of Kelly S. v. Farah M.*, 139 A.D.3d 90, 97; *Yonaty v. Mincolla*, 97 A.D.3d at 145). The New York Legislature enacted the Marriage Equality Act in June 2011 (L 2011, ch 95 [eff July 24, 2011]).

Based on the foregoing, we conclude that the false imputation of homosexuality does not constitute defamation per se. *Matherson*’s holding to the contrary should no longer be followed. Furthermore, the additional allegation that the plaintiff viewed gay pornography on the church’s computer likewise does not fit within any of the categories of defamation per se. Therefore, the plaintiff was required to allege special damages. He failed to do so, and, consequently, his cause of action alleging defamation per se must be dismissed (*see Yonaty v. Mincolla*, 97 A.D.3d at 146).

Note 1. The category of “slander per se” constituted a clear mechanism to assist plaintiffs’ recovery by allowing them to forgo proving that the defamatory statement had harmed them financially. It also reflected the legal system’s judgment about the sorts of values, attributes, identity markers and lifestyle choices that were intolerable as comments about an individual. The court refers to *Yonaty v. Mincolla*, a 2011 New York case in which the court upheld the use of homosexuality as one of the defamation per se categories. *Yonaty* was decided only a few days before the state adopted legislation protecting same-sex marriage, suggesting the misalignment of the judicial and legislative branches of New York at the time. In 2012, *Yonaty* was overturned on appeal but the underlying categorization of homosexuality as per se defamatory remained good law in the state until the ruling in *Laguerre*. Does it surprise you that despite the legislative legalization of same-sex marriage in 2011, New York state

had not yet abandoned this outdated categorization almost a full decade later? What are the competing interests that courts were likely balancing?

In California, the law was not much further ahead of New York in doing away with outdated defamation rules that conveyed these homophobic implications. In 2017, one court did expressly rule that being incorrectly described as transgender was not grounds for defamation per se. Richard Simmons, a former fitness star, had sued a tabloid and other defendants for claiming that his retreat from the media had been due to his plan to undergo transition. The court stated that “being misidentified as transgender is not libelous per se because such an identification does not expose ‘any person to hatred, contempt, ridicule, or obloquy, or which causes him to be shunned or avoided, or which has a tendency to injure him in his occupation.’” While, as a practical matter, the characteristic may be held in contempt by a portion of the population, the court will not validate those prejudices by legally recognizing them.” *Simmons v. American Media, Inc.*, No. BC660633, 2017 WL 5325381, at *7 (Cal.Super. Sep. 01, 2017). The ruling was heralded as a victory for transgender law; even though the court acknowledged existing biases, it refused to validate them by integrating them into the law of defamation.

Note 2. Judge versus Jury. Whether a communication is susceptible to defamatory interpretation is a question of law to be determined by the judge. *See e.g. Bongino v. Daily Beast Co., LLC*, 477 F. Supp. 3d 1310, 1317 (S.D. Fla. 2020); *Smith v. Maldonado*, 72 Cal. App. 4th 637, 647, 85 Cal. Rptr. 2d 397, 403 (1999), as modified (June 23, 1999). However, the jury is tasked with determining whether the potentially defamatory communication was indeed understood in the way the plaintiff alleges. The defamatory nature of the communication often involves questions of fact such as involve context-sensitive assessment of where and when the communications were perceived and by whom. In addition, the allegedly defamatory communication should not be read in isolation but must be considered holistically, as it was conveyed along with other communications, acts or gestures. Do you think judges or juries are better suited for the work of determining whether a communication is defamatory? Who would you want to determine the claim if you were a plaintiff? Would it differ if you were the defendant?

Note 3. Practical Impact of Per Se Categorizations. In some jurisdictions, the various forms of “per se” actions that permit a presumption of damages are dealt with as “defamation per se.” For example, in *Sleem v. Yale University*, the plaintiff, Dimitri Sleem, was a Yale alumnus who sued the university for defamation (and NIED) over a publication made in relation to his upcoming fifteenth-year reunion. The Alumni Office had sent most alumni a questionnaire about their collegiate experiences but they sent Sleem’s questionnaire to the address he had had on file during college (which was in Kingston, Jamaica). The Alumni Office possessed his updated address, which was in North Carolina, as well as his phone number, so it’s unclear why they sent the questionnaire to the wrong address. In any event, he never received his invitation and someone else unidentified filled it out pretending to be Sleem. The entry was never corrected or edited, and included the following lines: “I have come to terms with my homosexuality and the reality of AIDS in my life. I am at peace.” Yale had the questionnaire for five months before copies of the questionnaires were made into books and sent to other members of the Class of 1975. No attempt was made to verify the statements made about Plaintiff in the personal statement bearing his name even though there were people and resources that could have helped confirm the statements. In addition, two staff members spent a total of 146 hours proofreading the “Yale 1975—Fifteen Years Out” reunion book. They confirmed by deposition that they were aware

that AIDS is an infectious disease and that no other entry in the “Yale 1975—Fifteen Years Out” book alleged that the individual has a sexually transmitted disease. *Sleem v. Yale Univ.*, 843 F. Supp. 57, 59, 59-60 (M.D.N.C. 1993) Sleem had no way of proving special damages, so his case would have failed had the statements not qualified as some form of defamation per se. (A quirk of North Carolina libel law permitted the case to survive a motion for summary judgment without deciding the issue of defamation per se, and the parties appear to have settled. The court’s criticism of Yale’s conduct with respect to the defamatory publication telegraphed likely success on at least some issues on the merits of Sleem’s case.)

Do you think it is likely that an alumni publication will cause pecuniary losses? If it seems unlikely to do so, should there be another way of recognizing the harms someone like Sleem would suffer as a result of Yale’s conduct? Is pecuniary loss the right threshold for defamation claims, in other words? Do you think the context of the publication ought to make special damages unnecessary irrespective of the nature of the defamatory content? Does permitting a presumption of damages with some form of defamation per se get the balance right between protecting reputational interests and also not overly burdening speech?

Note 4. To what extent does liability for defamation require that a claim be reasonably credible? If a student posted on social media that their law professor was not just incompetent but the worst professor in the world, the statement would be inactionable because it can be discounted as pure opinion. (You’ll learn more about the status of opinions when covering defenses, *infra*.) Consider the following examples.

Student One posts on social media that their law professor was incompetent. Without more, this is merely an opinion and lacks any verifiable (whether true or false) statements of fact.

Student Two posts the same but also provides details explaining their assessment of the professor’s incompetence and wondering whether this incompetence could cause law students to fail their future bar exams. This communication remains primarily opinion even if it also contains a professionally negative implication that the alleged incompetence could translate into concrete and negative outcomes (students failing the bar).

Student Three posts that her law professor was incompetent and that her entire section felt they never learned the topic well enough to pass the bar. Moreover, she shares a graph of recent bar exam results showing a sharp decrease in bar passage, along with the caption, “See what I mean??” Now there is a statement of fact: fewer students passed the bar (fact) and a communication (“See what I mean??”) which intentionally attributes the decreased passage to the professor’s alleged incompetence. While the incompetence is still the student’s opinion and not actionable by itself, attaching it to verifiable facts that prove to be false will make the communication actionable. Of course if the statements are verifiably true, the defamation action will fail. But the point is the extent to which a statement is a credible statement of fact versus purely an expression of opinion or even a fictitious or fantastic invention, as in the final example.

Student Four posted that their law professor was an evil villain in charge of a giant weather machine which was responsible for causing bad weather during every exam week. Here the claim is not defamatory because there is no reasonable way to believe it as a potential statement of fact that happens to be false. Mere fantasy is not usually enough to cause a claim to be

cognizably defamatory. Often tabloids benefit from this presumption, falling back on the notion that nobody believes the stories they report. Consider as you read the next case where the line falls between fact and opinion as well as fact and fiction, and tort law's role in assessing that.

**Peoples Bank & Trust Co. v. Globe Int'l, Inc., U.S. Dis. Ct. W.D. Arkansas
(1992)
(786 F. Supp. 791)**

The plaintiff, Peoples Bank and Trust Company of Mountain Home, conservator of the estate of Nellie Mitchell, an aged person, by amended complaint filed September 24, 1991, brought defamation [***] and intentional infliction of emotional distress claims against the defendant, Globe International, Inc. d/b/a "Sun". Mrs. Mitchell is a 96-year-old resident of Mountain Home, Arkansas. She has operated a newsstand on the town square since 1963. Prior to that she delivered newspapers on a paper route, and according to the evidence, still makes deliveries to certain "downtown" business establishments and select customers.

It appears that Nellie, as she is known to almost everyone in this small Ozark Mountain town, is a town "landmark" or "treasure". She has cared for herself and raised a family as a single parent for all of these years on what must have been the meager earnings of a "paper girl." According to the evidence, the newspaper stand which she operates was once a short, dead end alley between two commercial buildings on the town square. She apparently gained permission to put a roof over the alley and this became her newsstand and sole source of livelihood, apparently providing life's necessities for her and her family to this day. When one of the lawyers asked Nellie during the course of her testimony *793 whether she lived with her adult daughter, Betty, she quickly replied, "No, Betty lives with me."

The basis of the plaintiff's claims is an article and picture that appeared in the October 2, 1990, edition of the *Sun*. The October 2 edition published a photograph of the plaintiff in conjunction with a story entitled:

SPECIAL DELIVERY

World's oldest newspaper carrier, 101, quits because she's pregnant!

I guess walking all those miles kept me young

The "story" purports to be about a "papergal Audrey Wiles" in Stirling, Australia, who had been delivering papers for 94 years. Readers are told that Ms. Wiles became pregnant by "Will" a "reclusive millionaire" she met on her newspaper route. "I used to put Will's paper in the door when it rained, and one thing just kind of led to another."

In words that could certainly have described Nellie Mitchell, the article, which was in the form and style of a factual newspaper account, said:

[S]he's become like a city landmark because nearly everyone at one time or another has seen her trudging down the road with a large stack of papers under her arm.

A photograph of Nellie, apparently “trudging down the road with a large stack of papers under her arm” is used in conjunction with the story. The picture used in the October 2 edition of the *Sun* had been used by the defendant in a reasonably factual and accurate article about Mrs. Mitchell published in another of the defendant’s publications, the *Examiner*, in 1980. [***]

Testimony at trial indicated that most of the defendant’s articles are created “TOH” or “top of the head”, in the words of John Vadar, editor of the *Sun*. That is, the authors, none of whom use their real name, are given a headline and a picture and then “make up” the accompanying stories. In fact, according to the evidence, the editor and perhaps others “make up” a series of headlines for stories to appear in each issue, and they are placed on a table. The “reporters” or perhaps, according to defendant’s contentions at the trial, their “authors of fiction” select from this list the stories they wish to write.²¹⁷

*795 John Vadar, indicated that, when the picture of Mrs. Mitchell was selected, it was assumed she was dead. The *Sun*’s stated policy was to illustrate its articles with pictures of individuals from other countries who would not be damaged by the publication being circulated in the United States. The use of Mrs. Mitchell’s picture was merely a “mistake.”

Although defendant’s contention during the trial was that Nellie Mitchell could not have been defamed because the publication contained only fiction readily recognized as such by reasonable readers, some of its “authors” testified that some of the articles were factual or at least based on fact, and it became obvious that even they could not tell the difference. Some of defendant’s own witnesses could not agree which articles were purely fantasy and which were true or at least had some factual basis. For example, at trial Mr. Silver testified that an article about a farmer becoming a millionaire by making whips for wife beaters was a true story while Mr. Levy, also a witness for the defendant, stated the story was false. [***]

The jury heard the evidence and studied the exhibits which included the very issue of the *Sun* in which Nellie’s heretofore unsullied photograph, and thus her very “being”, were literally buried in what reasonable jurors might find is muck, mire and slime spewed forth by defendant, some of which is described as follows:

A front page containing Nellie’s picture surrounded by headlines promising stories about:

HUSBAND & WIFE LIVE TOGETHER WITHOUT SPEAKING FOR 56 YEARS

WOMAN CLAIMS: I’M MOM OF JIM BAKKER’S LOVE CHILD

²¹⁷ In this respect, Paul Greenberg, Pulitzer-prize winning journalist testified in a deposition used as evidence in this case, while being questioned by defendant’s attorney:

Q. If the author testifies that he made up a story, isn’t that fiction?

A. Sir, it’s false. All things that are false are not necessarily fiction.

Q. Tell me the difference between “false” and “fiction.”

A. I can give you an illustration. William Faulkner wrote fiction. Pravda published falsehoods.

BROTHER & SISTER MARRIAGE SHOCKER—

After 30 yrs of forbidden love, they would rather go to jail than divorce

PARALYZED WOMAN WALKS AFTER BEING HIT BY LIGHTNING

WORLD’S MOST HONEST COP ARRESTS OWN MOTHER—We later learn it is for picking flowers in the park.

*796 And inside pages again with Nellie’s photograph buried in what appear to be news stories about:

HIGHWAY TO HELL—*Wicked witch casts her deadly curse on intersection mangling 21—*accompanied by graphic photographs of mangled automobiles sitting at an intersection where the “witch” had caused a serious accident.

DRUG DEALERS’ DEVIL DOGS REPLACE PIT BULLS

BOY, 12, GETS OWN LAWYER TO DIVORCE DAD IN CUSTODY FIGHT

Revealed for first time: **CHURCHILL’S CLOSE ENCOUNTERS WITH UFO ALIENS—**the articles discloses that, although Winston Churchill implored them to do so, they declined to help the world defeat Hitler.

Mothers describe night of terror during ... **20-MILE RIDE WITH A HEADLESS GHOST**

‘DEAD MAN’ REVIVES AS DOCS TAKE ORGANS

ROAD KILL CANNIBAL—*He eats accident victims—*a news story, accompanied by a photograph of a black man whom, the story says, had applied to the government of the “African country of Swaziland” to be allowed to pick up from along roadsides and eat bodies of persons killed on the roadway. He describes the taste of human flesh, saying that he prefers adult meat because it is “firm, succulent and salty and doesn’t require seasonings”, while, on the other hand, “children’s meat is revolting because it tastes sweet and sticks to the teeth.”

FARMER BECOMES A MILLIONAIRE MAKING WHIPS FOR WIFE BEATERS—the story which at least one of defendant’s “authors” thought to be true.

HELL SCHOOL ... *Where students are chained to learn and whipped if they don’t read properly*

STUDENTS KILL TEACHER WITH VODOO DOLL

FARMER KILLS SELF BY BREATHING COW GAS—*He dies with his beloved animals*

It may be, as defendant in essence argues, that Mrs. Mitchell does not show a great deal of obvious injury, but a reasonable juror might conclude, after hearing the evidence and viewing the *Sun* issue in question, that Nellie Mitchell’s experience could be likened to that of a person who had been dragged slowly through a pile of untreated sewage. After that person had showered and a few weeks have

passed, there would be little remaining visible evidence of the ordeal which the person had endured and the resulting damages incurred, but few would doubt that substantial damage had been inflicted by the one doing the dragging. This court is certainly in no better position to determine what that is “worth” than 8 [fn] jurors picked from the citizenry of the Harrison Division of the Western District of Arkansas to hear and decide this case. The court concludes that reasonable jurors could find that it is “worth” a great deal to suddenly find your likeness buried in the slime of which this publication was made, directly in front of an article describing the relative tastiness of adult human flesh compared to that of children.

Defendant undoubtedly has the Constitutional right²¹⁸ to publish “newspaper stories,” “literature,” “fiction,” or whatever the articles described above and others in this issue are, but when it does and damages others by doing so, our system literally demands that the injured person be adequately compensated in an attempt to make them whole, or as whole as money can *797 make them. A properly picked jury made that determination after hearing ample evidence to create a jury question, and our system does not permit this judge to substitute his judgment for that of the jury.

[***] Plaintiff argues that the defendant’s method of publishing—not distinguishing between truth or fiction, off the top of their head, out of whole cloth—demonstrates at the very least reckless disregard. In fact, the defendant’s method of publishing was one of the major considerations resulting in the earlier denial of defendant’s summary judgment motion. See *Mitchell v. Globe International Publishing, Inc.*, 773 F. Supp. 1235, 1240 (W.D.Ark.1991). In that opinion we stated:

The court cannot say as a matter of law that the article is incapable of being interpreted as portraying actual events or facts regarding the plaintiff. The “facts” conveyed are not so inherently impossible or fantastic that they could not be understood to convey actual facts. Nor can we say that no person could take them seriously. Moreover, even if the headline and certain facts contained in the article could not be reasonably believed other facts *e.g.*, the implication of sexual promiscuity, could reasonably be believed.

In making this determination we ‘consider the surrounding circumstances in which the statements were made, the medium by which they were published and the audience for which they were intended.’ *Dworkin [v. Hustler Magazine, Inc.]*, 668 F. Supp. [1408] at 1416. The articles are written in a purportedly *799 factual manner. No distinction is made between those articles that are wholly fictional and the articles that are intended to be factual. Fictional articles are not denoted as such. The *Sun* apparently intends for the readers to determine which articles are fact and which are fiction or what percentage of a given article is fact or fiction.

The layout, captions, and style of writing contained in the article is similar in format to news articles. There are no cautionary statements appearing in this article or to the court’s knowledge in the entire edition of the *Sun. Id.*

²¹⁸ This court once said, in another context, that: “While few of us would want to change our system which protects such a large array of “rights,” it may be that we have more than most of us need, and more than is good for a majority of us.” *Norwood v. Soldier of Fortune Magazine, Inc.*, 651 F. Supp. 1397 (W.D.Ark.1987).

After hearing the testimony in this case, the court believes the jury could have, and apparently did, find that the defendant intended their readers to construe the article in question as conveying actual facts or events concerning Mrs. Mitchell or at the very least that the defendant recklessly failed to anticipate that the article would be so construed. [***] The defendant could very easily indicate to its readers in some fashion that the material conveyed in the *Sun* is fiction if it really intended that its readers recognize that the articles are false and made up fantasy. The court believes that it could be inferred from the manner of publication that the defendant intends its readers to believe its articles are conveying actual facts or at the very least leave the reader in doubt as to what portions are factual and what portions are pure fantasy.²¹⁹ [***]

Defendant argues there is no evidence to support the [jury's] award of \$650,000 in compensatory damages. We are informed that this is the highest award in Boone county history and it is also the highest jury award for compensatory damages in a defamation, invasion of privacy, or outrage case in the history of the State of Arkansas. Defendant provides the court with a comparison of awards made in other cases. (Defendant's brief at 4). Without intending to be flippant, the court's response is, "so what?" As far as those same records show, there has never before been a case like this in Boone County or the State of Arkansas. [***]

In general awards for mental anguish or pain and suffering are left to the discretion of the jury since these are highly subjective elements of damage and are extremely hard to quantify. *802 [***] The jury in this case was required to quantify damages for mental distress. We believe there is no basis on which to determine what portion, if any, of the damages awarded should be remitted. To do so would merely be a substitution of this judge's judgment for that of the jury. [***] [M]ental anguish is an element of damage that is not easily susceptible to measurement in economic terms. [***]

Defendant also argues that the award of \$850,000 punitive damages reflects passion and prejudice. At trial after the jury returned its verdict on the liability and compensatory damage aspects of the case, it was given a separate instruction listing various considerations that could be utilized in determining the amount of punitive damages to be awarded. [***] In this case the jury found that the defendant committed intentional torts, one of them requiring a finding of actual malice. Additionally, the ratio of punitive to compensatory damages does not suggest excessiveness.

Even if this court would, if it had been the trier of fact, have awarded less damages, that is not sufficient for the court to substitute its judgment for that of the jury. The court would only be speculating as to what is "right" if it were to reduce the verdicts. The court cannot say that the verdicts "shock the conscience of the court." [***]

The court believes and finds that there was ample evidence to support the jury's verdict in this case. Certainly, reasonable minds may differ, and the verdict was not against the "clear weight", "overwhelming weight", or "great weight" of the evidence.

²¹⁹ Although the court would certainly not allow a newspaper poll to affect in any way its judgment in this matter, it is interesting to note the responses to a poll contained in the December 10, 1991, issue of the Arkansas Democrat-Gazette. Readers were asked: "Do you believe the stories in the supermarket tabloids are real?" The response: Yes—53.1%, No—46.9%. While the article reporting the poll contained the disclaimer that it did not purport to be a "scientific survey and reflects only the opinion of those who choose to participate", it at least indicates that over one-half of those who bothered to respond either believed articles in supermarket tabloids to be true or lied about it. It, of course, might be that only people who read and believe supermarket tabloids respond to call in telephone polls.

Note 1. If authors of various communications are unclear on the truth or fiction of their writing, should that fact be used against them to create a presumption of falsity? Why or why not? What facts struck you as most important to the legal determination in this fact pattern, and why?

Note 2. Could Nellie have proven special damages in this case? Were you convinced by the court's analysis of her damages? Why or why not?

Note 3. How significant do you think it was that the victim of the defamation in this case was a vulnerable elderly woman, a beloved community figure now subject to a legal conservatorship? Would this have come out the same way had it been a case about an unpopular or little-known community recluse? How about if the plaintiff had been a muscular young man?

Note 4. What was the impact of the jury's role in this case, do you think?

Note 5. Viewpoints and Values. In its insistence on the plaintiff's right to their reputation—even among a small or countercultural group—defamation seeks to avoid playing favorites. In that sense, it reflects some reasoning found in First Amendment jurisprudence, which requires viewpoint neutrality. Yet defamation law is hardly neutral. All throughout a defamation action, if a plaintiff claims that a communication has injured their reputation, a court must determine whether that communication is capable of carrying defamatory meaning and whether it was in fact understood in the way the plaintiff alleges. Hence questions of meaning and intention frequently present themselves, and value judgments about whom the law protects and against what are omnipresent. In what ways do you imagine this might affect the kinds of claims that succeed and the kinds of parties willing to (or able to) bring defamation actions?

Note 6. Audience for the Defamation.

Recall that the tort of defamation protects a person's reputation. The Restatement (Second) of Torts § 559 defines a communication as defamatory “if it tends so to harm the reputation of another as to lower him in the estimation of the community or to deter third persons from associating or dealing with him.” Key to this definition is that the interest the tort protects would be meaningless if it protected only reputational interests with a community that did not matter to the plaintiff.

It is well-settled that defamation does not protect only the kind of reputation that everyone must agree is socially valuable; put another way, defamation does not only protect reputational interests as those are conceived of in the minds of “right-thinking people.” *Grant v. Reader's Digest Ass'n*, 151 F.2d 733, 734-735 (2d Cir. 1945). Judge Learned Hand's opinion in *Grant* states: “A man may value his reputation even among those who do not embrace the prevailing moral standards; and it would seem that the jury should be allowed to appraise how far he should be indemnified for the disesteem of such persons ... We do not believe, therefore, that we need say whether ‘right-thinking’ people would harbor similar feelings... It is enough if there be some... who would feel so, even though they would be ‘wrong-thinking’ people if they did.”

There is an outer limit to this flexibility, however. One court describes the problem aptly, framing it in terms of the cultural diversity in its jurisdiction:

Whether an utterance is defamatory depends on the values of the listener. Even in an ethnically homogeneous culture these values will not be uniform, and it is not always easy to predict what will be taken as defamatory. [fn] The confusion is compounded in

Alaska, because among the several ethnic groups which reside here there may be divergent views on what is, and what is not, disreputable. *Gottschalk v. State*, 575 P.2d 289, 293 (Alaska 1978)

In a footnote, the court expands on the challenges of determining defamatory meaning:

Establishing a standard against which potentially defamatory statements may be measured generates considerable difficulty in a democratic society which prides itself on pluralism. [***] American courts generally recognize that a person may suffer real damage by statements which tend to tarnish his reputation within a particular group or class even though the measuring group may be a small minority. Examples collected by Prosser include publication of a person's picture in connection with a whiskey advertisement, a statement that a person is about to be divorced, and the insinuation that a white man is a black man, that a businessman is a price cutter, or a Kosher meat dealer sells bacon. See, W. Prosser, *Handbook on the Law of Torts* s 111, at 743-44 (4th Ed. 1971). Taken to an extreme, this policy finds its limit in cases where the minority group is either insignificantly small or its values clearly anti-social. An example would be a thief attempting to recover damages against a person who charged him with being an informer.

A parallel problem is that what is defamatory changes over time. One commentator illustrates this as follows: An interesting example . . . is the line of British cases in which the alleged defamation consisted in calling a man a "Papist." Such a charge was held not actionable when James I was on the throne, but a contrary result was reached during the rule of Charles II, and it was also libelous during the period between the abdication of James II and the accession of William and Mary, when to call a man a Papist would subject him to danger. (citations omitted) 1 Harper & James, *The Law of Torts* s 5.1, at 353 (1956).

A more contemporary example might be labeling someone a "communist" or a "marxist", which within the past 50 years has been considered first defamatory, then non-defamatory, and next defamatory again, depending largely on United States foreign policy changes. W. Prosser, *supra* at 744 nn. 3, 4. *Id.*

How should tort law manage the historical fluctuation regarding various allegedly defamatory terms? What is the relationship between proving defamatory meaning and being able to prove damages given the dynamic nature of language and identity?

The next case provides historical perspective on the way that social values infuse the law of defamation.

Malone v. Stewart, Supreme Court of Ohio, In Bank (1846) (15 Ohio 319)

***319** This is a writ of error, directed to the court of common pleas of Jefferson county.

The action below was case for slander. The words charged in the declaration were, that Olive Stewart, the wife of said James Stewart, had said of the plaintiff below that she was a hermaphrodite. To the declaration the defendants interposed ***320** a general demurrer, and the court of common pleas sustained the demurrer, and gave judgment for the defendants. [***]

It is contended that the words charged in the declaration are not actionable. The court of common pleas took this view, and sustained the demurrer. It is said that the charge imports neither crime, guilt, nor moral turpitude. It is a well-established principle of law, that words which impute a charge necessarily tending to injure a man, or his trade, or occupation, or profession, or to exclude him from society, are actionable in themselves.

A more gross or indelicate slander could not well have been uttered against a female—especially a young girl—or one more calculated to wound her feelings and do her mischief. It unsexes her; makes her a thing to be stared at; converts her into a monster, whose very existence is shocking to nature; and would be certain, among the young or thoughtless, to bring her into ridicule and contempt; and excludes her from social intercourse and all hopes of marriage. It is infinitely worse than a charge of incontinence, as to its injurious results, to the feelings and prospects of the female.

To hold that there was no remedy for a case of this sort, would be an utter disgrace to the law and ourselves. It is said that, if the plaintiff would inquire around, and if she could ascertain that she had been especially injured to a certain amount, in dollars and cents, the law would assist her to recover it; in other words, that it is a case where the action must be sustained upon the ground of special damage. It is said the common law has not gone further; that the English courts have not gone further. It is sufficient to reply, that this court will not permit so gross a wrong to pass without a remedy. We shall apply the spirit of the law to embrace every case property falling within it.

It is precisely that sort of charge calculated to do infinite mischief, and of that vague and indefinite kind which can neither be met nor answered.

The case falls clearly within the oldest and soundest principles of the law, when properly understood and rightly applied. It is admitted that, if words are spoken to injure a man, to the value of a few dollars and cents, in his trade, it is actionable; but contended that, to speak words of a young girl, which necessarily inflict the deepest wound upon her feelings; break up her hopes, and exclude her from society, is not actionable. Such a conclusion cannot be tolerated. This court, in protecting reputation—a remedy for an injury to which is guaranteed by the constitution—will be careful that the judicial decisions of the land shall reflect that same delicate and profound respect for female character and feeling, which constitutes the proudest and dearest characteristic of our people. We hold it a sound principle of law, that words spoken of a female, which have a tendency to wound her feelings, bring her into contempt, and prevent her from occupying such position in society as is her right, as a woman, are actionable in themselves.

Judgment reversed, and remanded for further proceedings.

Note 1. When the court refers to words “actionable in themselves,” it is referring to slander per se. What is the rule here, in your own words? How far does it appear to go (descriptively)? You can certainly query how far it *should* go normatively but the descriptive question offers a valuable opportunity to formulate a rule and test what might allow recovery or fail to do so under the given rule. You can also formulate a pair of rules or a rule and sub-rule; the important thing is to practice stating the reasoning in terms of a principle that a subsequent court could apply.

Note 2. The court appears to ground its holding in the notion that the injury to a man’s trade ought not to be more actionable than the injury to a woman’s feelings: “if words are spoken to injure a man, to the value of a few dollars and cents, in his trade, it is actionable; but contended that, to speak words of a young girl, which necessarily inflict the deepest wound upon her feelings; break up her hopes, and exclude her from society, is not actionable. Such a conclusion cannot be tolerated.” Given what you know about the reluctance of courts to recognize claims for emotional distress, especially in the late 19th century when this case was decided, how might you explain what is different about this case? Do note that the wounded feelings themselves are not the cognizable injury; the alleged loss of reputation is the injury but it causes the emotional suffering. Always recall that the primary injury to seek and measure is reputational, not emotional. The damages may take that suffering into account, but they are not proof that the defamation occurred.

Note 3. The court’s rhetoric and substance both display a commitment to a particular, stable version of gender (and sexual identity) that the allegedly defamatory communications threatens. If the plaintiff is bothered by the communication, and the court permits recovery, should it be problematic if this is the way the court reasons its way to this outcome? Does your answer depend on whether the special damage requirement is usually ignored or treated as a genuine hurdle?

Scholars have noted that the rigid construction of gender and sexual identity in judicial opinions can create harm apart from the merits of the case, as well as in the substantive issues before the court. One writes:

[I]n tort litigation, courts do not take a neutral approach toward considering and weighing the credibility of competing narratives [about gender and sexual identity]. Instead, courts privilege narratives which treat sexual identity as if it were naturally binary, even as the cases in front of them suggest the opposite. In this respect, courts treat sexual identity quite differently than gender identity. While gender identity is understood as a cultural phenomenon, which may have elements of artificial construction, ... when it comes to sexual identity,” courts fall back on binary notions and cast those as the only “natural” possibilities. ... [P]rivileging ...one narrative of sexual identity above others in tort litigation has political implications that go well beyond the denial of the benefits of tort litigation to particular classes of people. The most important of these political effects is the impact of the litigation on our political consciousness and our perceptions of what is possible. When legal narratives, such as those produced in tort litigation, echo those that are expressed outside the courtroom, the law provides political and cultural legitimacy for dominant sexual identity narratives and delegitimizes others. Anne Bloom, *To Be Real: Sexual Identity Politics in Tort Litigation*, 88 N.C. L. Rev. 357, 366 (2010)

What role should tort law play, if any, in creating or challenging the cultural legitimacy of narratives about sexual identity? What alternatives exist? In the next case, Judge Learned Hand (originator of the “Negligence Calculus” case among other well-regarded opinions) reflects the many biases of his era. The case illustrates that recovery for defamation was available in order to “protect” the plaintiff’s reputation against the suggestions of racial impurity, sexual difference or impurity, and many kinds of disability or disease. It also exemplifies the way that judicial reasoning encoded particular values about social identity without being deliberate or transparent about the constructed nature of its value system.

Burton v. Crowell Pub. Co., Circuit Court of Appeals, Second Circuit (1936) (82 F.2d 154)

This appeal arises upon a judgment dismissing a complaint for libel upon the pleadings. The complaint alleged that the defendant had published an advertisement — annexed and incorporated by reference — made up of text and photographs; that one of the photographs was “susceptible of being regarded as representing plaintiff as guilty of indecent exposure and as being a person physically deformed and mentally perverted”; that some of the text, read with the offending photograph, was “susceptible of being regarded as falsely representing plaintiff as an utterer of salacious and obscene language”; and finally that “by reason of the premises plaintiff has been subjected to frequent and conspicuous ridicule, scandal, reproach, scorn, and indignity.”

The advertisement was of “Camel” cigarettes; the plaintiff was a widely known gentleman steeple-chaser, and the text quoted him as declaring that “Camel” cigarettes “restored” him after “a crowded business day.” Two photographs were inserted; the larger, a picture of the plaintiff in riding shirt and breeches, seated apparently outside a paddock with a cigarette in one hand and a cap and whip in the other. This contained the legend, “Get a lift with a Camel”; neither it, nor the photograph, is charged as part of the libel, except as the legend may be read upon the other and offending photograph. That represented him coming from a race to be weighed in; he is carrying his saddle in front of him with his right hand under the pommel and his left under the cantle; the line of the seat is about twelve inches below his waist. Over the pommel hangs a stirrup; over the seat at his middle a white girth falls loosely in such a way that it seems to be attached to the plaintiff and not to the saddle. So regarded, the photograph becomes grotesque, monstrous, and obscene; and the legends, which without undue violence can be made to match, reinforce the ribald interpretation. That is the libel.

The answer alleged that the plaintiff had posed for the photographs and been paid for their use as an advertisement; a reply, that they had never been shown to the plaintiff after they were taken. On this showing the judge held that the advertisement did not hold the plaintiff up to the hatred, ridicule, or contempt of fair-minded people, *155 and that in any event he consented to its use and might not complain.

We dismiss at once so much of the complaint as alleged that the advertisement might be read to say that the plaintiff was deformed, or that he had indecently exposed himself, or was making obscene jokes by means of the legends. Nobody could be fatuous enough to believe any of these things; everybody would at once see that it was the camera, and the camera alone, that had made the unfortunate mistake. If the advertisement is a libel, it is such in spite of the fact that it asserts nothing whatever about the plaintiff, even by the remotest implications. It does not profess to depict him as he

is; it does not exaggerate any part of his person so as to suggest that he is deformed; it is patently an optical illusion, and carries its correction on its face as much as though it were a verbal utterance which expressly declared that it was false.

It would be hard for words so guarded to carry any sting, but the same is not true of caricatures, and this is an example; for, notwithstanding all we have just said, it exposed the plaintiff to overwhelming ridicule. The contrast between the drawn and serious face and the accompanying fantastic and lewd deformity was so extravagant that, though utterly unfair, it in fact made of the plaintiff a preposterously ridiculous spectacle; and the obvious mistake only added to the amusement. Had such a picture been deliberately produced, surely every right-minded person would agree that he would have had a genuine grievance; and the effect is the same whether it is deliberate or not. Such a caricature affects a man's reputation, if by that is meant his position in the minds of others; the association so established may be beyond repair; he may become known indefinitely as the absurd victim of this unhappy mischance. Literally, therefore, the injury falls within the accepted rubric; it exposes the sufferer to "ridicule" and "contempt." Nevertheless, we have not been able to find very much in the books that is in point [*sic*], for although it has long been recognized that pictures may be libels, and in some cases they have been caricatures, in nearly all they have impugned the plaintiff at least by implication, directly or indirectly uttering some falsehood about him. [***]

The defendant answers that every libel must affect the plaintiff's character; but if by "character" is meant those moral qualities which the word ordinarily includes, the statement is certainly untrue, for there are many libels which do not affect the reputation of the victim in any such way. Thus, it is a libel to say that a man is insane [cc] or that he has negro blood if he professes to be white (*Stultz v. Cousins* [C.C.A.6] 242 F. 794); or is too educated to earn his living (*Martin v. Press Pub. Co.*, 93 App.Div. 531); or is desperately poor (*Moffatt v. Cauldwell*, 3 Hun [N.Y.] 26); or that he is a eunuch (*Eckert v. Van Pelt*, 69 Kan. 357); or that he has an infectious disease, even though not venereal (*Villers v. Monsley*, 2 Wils. 403; *Simpson v. Press Pub. Co.*, 33 Misc. 228); or that he is illegitimate (*Shelby v. Sun P. & P. Ass'n*, 38 Hun [N.Y.] 474, affirmed on opinion below, 109 N.Y. 611); or that his near relatives have committed a crime (*Van Wiginton v. Pulitzer Pub. Co.*, 218 F. 795 [C.C.A.8]; *Merrill v. Post Pub. Co.*, 197 Mass. 185); or that he was mistaken for Jack Ketch (*Cook v. Ward*, 6 Bing. 409); or that a woman was served with process in her bathtub (*Snyder v. New York Press Co.*, 137 App.Div. 291). It is indeed not true that all ridicule (*Lamberti v. Sun P. & P. Ass'n*), or all disagreeable comment (*Kimmerle v. New York Evening Journal, Inc.*, 262 N.Y. 99; *Cohen v. New York Times Co.*, 153 App.Div. 242), is actionable; a man must not be too thinskinny or a self-important prig; but this advertisement was more than what only a morbid person would not laugh off; the mortification, however ill-deserved, was a very substantial grievance.

156** A more plausible challenge is that a libel must be something that can be true or false, since truth is always a defense. It would follow that if, as we agree, the picture was a mistake on its face and declared nothing about the plaintiff, it was not a libel. We have been able to find very little on the point. In *Dunlop v. Dunlop Rubber Co.* (1920) 1 Irish Ch.&Ld.Com. 280, 290-292, the picture represented the plaintiff in foppish clothes, and the opinion seems to rely merely upon the contempt which that alone might have aroused, but those who saw it might have taken it to imply that the plaintiff was in fact a fop. [] The gravamen of the wrong in defamation is not so much the injury to reputation, measured by the opinions of others, as the feelings, that is, the repulsion or the light esteem, which those opinions engender. We are sensitive to the charge of murder only because our fellows deprecate

it in most forms; but a head-hunter, or an aboriginal American Indian, or a gangster, would regard such an accusation as a distinction, and during the Great War an “ace,” a man who had killed five others, was held in high regard.

Usually it is difficult to arouse feelings without expressing an opinion, or asserting a fact; and the common law has so much regard for truth that it excuses the utterance of anything that is true. But it is a non sequitur to argue that whenever truth is not a defense, there can be no libel; that would invert the proper approach to the whole subject. In all wrongs we must first ascertain whether the interest invaded is one which the law will protect at all; that is indeed especially important in defamation, for the common law did not recognize all injuries to reputation, especially when the utterance was oral. But the interest here is by hypothesis one which the law does protect; the plaintiff has been substantially enough ridiculed to be in a position to complain. The defendant must therefore find some excuse, and truth would be an excuse if it could be pleaded. The only reason why the law makes truth a defense is not because a libel must be false, but because the utterance of truth is in all circumstances an interest paramount to reputation; it is like a privileged communication, which is privileged only because the law prefers it conditionally to reputation. When there is no such countervailing interest, there is no excuse; and that is the situation here. In conclusion therefore we hold that because the picture taken with the legends was calculated to expose the plaintiff to more than trivial ridicule, it was prima facie actionable; that the fact that it did not assume to state a fact or an opinion is irrelevant; and that in consequence the publication is actionable.

Finally, the plaintiff's consent to the use of the photographs for which he posed as an advertisement was not a consent to the use of the offending photograph; he had no reason to anticipate that the lens would so distort his appearance. If the defendant wished to fix him with responsibility for whatever the camera might turn out, the result should have been shown him before publication. Possibly anyone who chooses to stir such a controversy in a court cannot have been very sensitive originally, but that is a consideration for the jury, which, if ever justified, is justified in actions for defamation.

Judgment reversed; cause remanded for trial.

Note 1. What is the defamatory statement or communication here?

Note 2. Proving Defamatory Meaning: Innuendo, Colloquium, and Inducement.

As mentioned above, defamation featured heightened pleading requirements at common law and it retains many archaic terms, at least in some jurisdictions. The Restatement describes a few of these.

Under common law pleading, in framing a declaration for defamation, when the defamatory meaning of the communication or its applicability to the plaintiff depended upon extrinsic circumstances, the pleader averred their existence in a prefatory statement called the “inducement.” In what was ordinarily called the “colloquium,” he alleged that the publication was made of and concerning the plaintiff and of and concerning the extrinsic circumstances. The communication he set forth verbatim and in the “innuendo” explained the meaning of the words. The function of the innuendo was explanation; it could not change or enlarge the sense or meaning of the words. It could only explain or apply them in the light of the other averments in the declaration.... Restatement (Second) of Torts § 563 (1977), **Comment f.**

If the communication is not obviously defamatory about the plaintiff, the plaintiff must prove the way in which the communication *may be understood as defamatory*. This is known as the **innuendo**. The plaintiff will also need to make clear that it refers to them. As noted above, this is also known as the **colloquium** or “of and concerning” requirement. In addition, the plaintiff may need to provide extrinsic evidence that offers context or proof of their claims about the innuendo and colloquium. This third element is known as the **inducement**. Be careful to keep the term as defined here narrowly tied to defamation since the word “inducement” has distinct and very different meanings in other legal contexts (such as criminal law and in intellectual property, for instance).

Note 3. Recall that *whether a statement can be read as defamatory* is a question for the judge. But whether it *was actually understood* in that way is a question for the jury. How would you explain this allocation of authority and do you think it makes sense, normatively, to divide and allocate the questions of defamatory meaning in this way?

Note 4. Why does Judge Learned Hand talk at length about the “defense” of truth?

Note 5. What do you observe about the constructed nature of what is or isn’t defamatory? Whom and what does the tort protect?

Note 6. Revisiting the Legacy (and Biases) of Renowned Jurists Like Learned Hand. Judge Learned Hand is held in extraordinarily high esteem as measured by his influence in tort law’s scholarship and case law. This case is rarely cited in full partly—I suspect—due to the offensive language and racist analogies. Yet this opinion, authored by one of the greatest American jurists, makes clear that at one time being a person of color was considered so negative a fact in terms of legal status that it was defamatory to falsely state that someone was a person of color if they were not (*Stultz v. Cousins*, cited above). Even more pointedly, Judge Learned Hand’s own analogizing leads him casually to equate Native Americans with gangsters and to assume without evidence that accusing them of murder would not be defamatory but rather celebratory. Ironically and unfortunately, an opinion vindicating the interests protected by the tort of defamation is, itself, false and defamatory towards Native Americans as a group.

How should the legacy of influential jurists be evaluated, and reevaluated, as our ideas about race, gender and other socially constructed categories evolve? Tort law’s fact-sensitivity and “reasonableness” standards are valuable in part because they can be tailored to the time and place of adjudication. The flip side of this jurisprudential benefit, however, is that tort law necessarily will be shaped by the various constructs and biases of its time. How should legal principles from earlier eras be considered and amended when applied in our (aspirationally) more progressive era? If we seek to overcome biases and make the law more just, how should we deal with the markers of racism, structural discrimination, and other implicit biases that infect the cases and scholarship of those the profession still holds in high esteem?

As you likely recall from Module 3 or your prior study of negligence, Judge Hand’s negligence calculus was formative in capturing how tort law might seek to balance deterrence and efficiency, and his many other opinions have remained crucial touchstones in many areas of the common law. It may be tempting to try to remove harmful speech or to minimize the work of people whose ideas are now plainly visible as biased and harmful. However, in a precedent-based system like ours, it could be significantly destabilizing to remove or ignore the work of a particular jurist, especially one with so powerful an imprint on the common law. Should the legal system try, in any event? How should the legacy of

influential jurists be evaluated, and reevaluated, as our ideas about race, gender and other socially constructed categories evolve? Casebook editors often make the decision to edit ugly language so as to sanitize earlier opinions. That choice is a harder one to defend in the context of defamation in which constructions of identity and value are central to allegations of defamatory meaning.

To what extent did Judge Learned Hand's peers do better on these points? Is the entire era tainted or just the work of a few? Does any potential solution require determining the scope of the problem? And if we retain the opinions and work of jurists like Learned Hand, should we remove offensive segments in cases like this one because they can be viscerally upsetting (or for other reasons), or should they remain a part of the record so that students and professors alike can highlight and learn from them, studying the forms of structural discrimination that were not even at issue or discussed in the case in chief? What are the risks, as well as the benefits, of adopting either the removal or highlighting approach? What other approaches can you imagine or would you recommend?

Should the legacy of racism and other discrimination be made more visible even when the subject matter doesn't seem to require it? In a system that bases progress on precedent, what duties does tort law have to revisit its historical foundations and revisit the voices and presumptions that shaped it?

Chapter 37. Constitutional Constraints

Contemporary defamation law has evolved to include substantial constitutional limits on the interests protected through the tort. At a pivotal moment in the Civil Rights Movement in 1964, the Supreme Court handed down a landmark decision, *New York Times v. Sullivan*, in which it ruled that Alabama's libel law unconstitutionally infringed on the First Amendment's protections for freedom of speech. *New York Times v. Sullivan* fundamentally altered the legal landscape. *Sullivan's* importance is hard to overstate. If you've worked in journalism or studied mass media or communications, you likely have lived with or studied its impact. It marks a critical moment when advocates succeeded in using the judicial system to expand journalists' capacity to report on civil rights violations, and it fundamentally changed the law of all U.S. jurisdictions with respect to defamation. By defining parameters within which the First Amendment trumped the rights of states to protect individuals' reputational interests, it "constitutionalized" state law essentially overnight.

"Heed Their Rising Voices," the advertisement at issue in *Sullivan* is reproduced below the opinion. The advertisement originally took up two full pages of the newspaper and was included as an appendix to the legal opinion.

Of further note: without intending anything derogatory or offensive, the opinion repeatedly uses the word "Negro." This was deemed a respectful term at the time but is no longer so. Please use appropriate contemporary language unless quoting verbatim from the text. (Alternatively, please follow any class agreements or ground rules your instructor has set on the topic).

N.Y. Times v. Sullivan, Supreme Court of the United States (1964) (84 S. Ct. 710)

Mr. Justice BRENNAN delivered the opinion of the Court.

We are required in this case to determine for the first time the extent to which the constitutional protections for speech and press limit a State's power to award damages in a libel action brought by a public official against critics of his official conduct.

Respondent L. B. Sullivan is one of the three elected Commissioners of the City of Montgomery, Alabama. He testified that he was 'Commissioner of Public Affairs and the duties are supervision of the Police Department, Fire Department, Department of Cemetery and Department of Scales' He brought this civil libel action against the four individual petitioners, who are Negroes and Alabama clergymen, and against petitioner the New York Times Company, a New York corporation which publishes the New York Times, a daily newspaper. A jury in the Circuit Court of Montgomery County awarded him damages of \$500,000, the full amount claimed, against all the petitioners, and the Supreme Court of Alabama affirmed. 273 Ala. 656, 144 So.2d 25.

Respondent's complaint alleged that he had been libeled by statements in a full-page advertisement that was carried in the New York Times on March 29, 1960. Entitled 'Heed Their Rising Voices,' the advertisement began by stating that 'As the whole world knows by now, thousands of Southern Negro

students are engaged in widespread non-violent demonstrations in positive affirmation of the right to live in human dignity as guaranteed by the U.S. Constitution and the Bill of Rights.’ It went on to charge that ‘in their efforts to uphold these guarantees, they are being met by an unprecedented wave of terror by those who would deny and negate that document which the whole world looks upon as setting the pattern for modern freedom. * * *’ Succeeding paragraphs purported to illustrate the ‘wave of terror’ by describing certain alleged events. The text concluded with an appeal for funds for three purposes: support of the student movement, ‘the struggle for the right-to-vote.’ and the legal defense of Dr. Martin Luther King, Jr., leader of the movement, against a perjury indictment then pending in Montgomery.

The text appeared over the names of 64 persons, many widely known for their ***714** activities in public affairs, religion, trade unions, and the performing arts. Below these names, and under a line reading ‘We in the south who are struggling daily for dignity and freedom warmly endorse this appeal,’ appeared the names of the four individual petitioners and of 16 other persons, all but two of whom were identified as clergymen in various Southern cities. The advertisement was signed at the bottom of the page by the ‘Committee to Defend Martin Luther King and the Struggle for Freedom in the South,’ and the officers of the Committee were listed.

Of the 10 paragraphs of text in the advertisement, the third and a portion of the sixth were the basis of respondent’s claim of libel. They read as follows:

Third paragraph: ‘In Montgomery, Alabama, after students sang ‘My Country, ‘Tis of Thee’ on the State Capitol steps, their leaders were expelled from school, and truckloads of police armed with shotguns and tear-gas ringed the Alabama State College Campus. When the entire student body protested to state authorities by refusing to re-register, their dining hall was padlocked in an attempt to starve them into submission.’

Sixth paragraph: ‘Again and again the Southern violators have answered Dr. King’s peaceful protests with intimidation and violence. They have bombed his home almost killing his wife and child. They have assaulted his person. They have arrested him seven times—for ‘speeding,’ ‘loitering’ and similar ‘offenses.’ And now they have charged him with ‘perjury’—a felony under which they could imprison him for ten years. * * *’

Although neither of these statements mentions respondent by name, he contended that the word ‘police’ in the third paragraph referred to him as the Montgomery Commissioner who supervised the Police Department, so that he was being accused of ‘ringing’ the campus with police. He further claimed that the paragraph would be read as imputing to the police, and hence to him, the padlocking of the dining hall in order to starve the students into submission.²²⁰ As to the sixth paragraph, he contended that since arrests are ordinarily made by the police, the statement ‘They have arrested (Dr. King) seven times’ would be read as referring to him; he further contended that the ‘They’ who did the arresting would be equated with the ‘They’ who committed the other described acts and with the ‘Southern violators.’ Thus, he argued, the paragraph would be read as accusing the Montgomery police, and hence him, of answering Dr. King’s protests with ‘intimidation and violence,’ bombing his home,

²²⁰ Respondent did not consider the charge of expelling the students to be applicable to him, since ‘that responsibility rests with the State Department of Education.’

assaulting his person, and charging him with perjury. Respondent and six other Montgomery residents testified that they read some or all of the statements as referring to him in his capacity as Commissioner.

It is uncontroverted that some of the statements contained in the two paragraphs were not accurate descriptions of events which occurred in Montgomery. Although Negro students staged a demonstration on the State Capitol steps, they sang the National Anthem and not 'My Country, 'Tis of Thee.' Although nine students were expelled by the State Board of Education, this was not for leading the demonstration at the Capitol, but for demanding service at a lunch counter in the Montgomery County Courthouse on another day. Not the entire student body, but most of it, had protested the expulsion, not by refusing to register, but by boycotting classes on *715 a single day; virtually all the students did register for the ensuing semester. The campus dining hall was not padlocked on any occasion, and the only students who may have been barred from eating there were the few who had neither signed a preregistration application nor requested temporary meal tickets. Although the police were deployed near the campus in large numbers on three occasions, they did not at any time 'ring' the campus, and they were not called to the campus in connection with the demonstration on the State Capitol steps, as the third paragraph implied. Dr. King had not been arrested seven times, but only four; and although he claimed to have been assaulted some years earlier in connection with his arrest for loitering outside a courtroom, one of the officers who made the arrest denied that there was such an assault.

On the premise that the charges in the sixth paragraph could be read as referring to him, respondent was allowed to prove that he had not participated in the events described. Although Dr. King's home had in fact been bombed twice when his wife and child were there, both of these occasions antedated respondent's tenure as Commissioner, and the police were not only not implicated in the bombings, but had made every effort to apprehend those who were. Three of Dr. King's four arrests took place before respondent became Commissioner. Although Dr. King had in fact been indicted (he was subsequently acquitted) on two counts of perjury, each of which carried a possible five-year sentence, respondent had nothing to do with procuring the indictment.

Respondent made no effort to prove that he suffered actual pecuniary loss as a result of the alleged libel.²²¹ One of his witnesses, a former employer, testified that if he had believed the statements, he doubted whether he 'would want to be associated with anybody who would be a party to such things that are stated in that ad,' and that he would not re-employ respondent if he believed 'that he allowed the Police Department to do the things that the paper say he did.' But neither this witness nor any of the others testified that he had actually believed the statements in their supposed reference to respondent. [***]

The trial judge submitted the case to the jury under instructions that the statements in the advertisement were 'libelous per se' and were not privileged, so that petitioners might be held liable if the jury found that they had published the advertisement and that the statements were made 'of and concerning' respondent.

The jury was instructed that, because the statements were libelous per se, 'the law * * * implies legal injury from the bare fact of publication itself,' 'falsity and malice are presumed,' 'general damages

²²¹ Approximately 394 copies of the edition of the Times containing the advertisement were circulated in Alabama. Of these, about 35 copies were distributed in Montgomery County. The total circulation of the Times for that day was approximately 650,000 copies.

need not be alleged or proved but are presumed,’ and ‘punitive damages may be awarded by the jury even though the amount of actual damages is neither found nor shown.’ An award of punitive damages—as distinguished from ‘general’ damages, which are compensatory in nature—apparently requires proof of actual malice under Alabama law, and the judge charged that ‘mere negligence or carelessness is not evidence of actual malice or malice in fact, and does not justify an award of exemplary or punitive damages.’ He refused to charge, however, that the jury must be ‘convinced’ of malice, in the sense of ‘actual intent’ to harm or ‘gross negligence and recklessness, to make such an award, and he also refused to require that a verdict for respondent differentiate between compensatory and punitive damages. The judge rejected petitioners’ contention that his rulings abridged the freedoms of speech and of the press that are guaranteed by the First and Fourteenth Amendments.

***717** In affirming the judgment, the Supreme Court of Alabama sustained the trial judge’s rulings and instructions in all respects. [c] It held that ‘(w)here the words published tend to injure a person libeled by them in his reputation, profession, trade or business, or charge him with an indictable offense, or tends to bring the individual into public contempt,’ they are ‘libelous per se’; that ‘the matter complained of is, under the above doctrine, libelous per se, if it was published of and concerning the plaintiff’; and that it was actionable without ‘proof of pecuniary injury * * *, such injury being implied.’ [c] It approved the trial court’s ruling that the jury could find the statements to have been made ‘of and concerning’ respondent, stating: ‘We think it common knowledge that the average person knows that municipal agents, such as police and firemen, and others, are under the control and direction of the city governing body, and more particularly under the direction and control of a single commissioner. In measuring the performance or deficiencies of such groups, praise or criticism is usually attached to the official in complete control of the body.’ [c]

In sustaining the trial court’s determination that the verdict was not excessive, the court said that malice could be inferred from the Times’ ‘irresponsibility’ in printing the advertisement while ‘the Times in its own files had articles already published which would have demonstrated the falsity of the allegations in the advertisement’; from the Times’ failure to retract for respondent while retracting for the Governor, whereas the falsity of some of the allegations was then known to the Times and ‘the matter contained in the advertisement was equally false as to both parties’; and from the testimony of the Times’ Secretary that, apart from the statement that the dining hall was padlocked, he thought the two paragraphs were ‘substantially correct.’ [c] The court reaffirmed a statement in an earlier opinion that ‘There is no legal measure of damages in cases of this character.’ [c] It rejected petitioners’ constitutional contentions with the brief statements that ‘The First Amendment of the U.S. Constitution does not protect libelous publications’ and ‘The Fourteenth Amendment is directed against State action and not private action.’ [c]

Because of the importance of the constitutional issues involved, we granted the separate petitions for certiorari of the individual petitioners and of the Times. [c] We reverse the judgment. We hold that the rule of law applied by the Alabama courts is constitutionally deficient for failure to provide the safeguards for freedom of speech and of the press that are required by the First and Fourteenth Amendments in a libel action brought by a public official against critics of his official conduct. [fn] ***718** We further hold that under the proper safeguards the evidence presented in this case is constitutionally insufficient to support the judgment for respondent. [***]

Under Alabama law as applied in this case, a publication is ‘libelous per se’ if the words ‘tend to injure a person * * * in his reputation’ or to ‘bring (him) into public contempt’; the trial court stated that the

standard was met if the words are such as to ‘injure him in his public office, or impute misconduct to him in his office, or want of official integrity, or want of fidelity to a public trust * * *.’ The jury must find that the words were published ‘of and concerning’ the plaintiff, but where the plaintiff is a public official his place in the governmental hierarchy is sufficient evidence to support a finding that his reputation has been affected by statements that reflect upon the agency of which he is in charge. Once ‘libel per se’ has been established, the defendant has no defense as to stated facts unless he can persuade the jury that they were true in all their particulars. [cc] His privilege of ‘fair comment’ for expressions of opinion depends on the truth of the facts upon which the comment is based. [c] Unless he can discharge the burden of proving truth, general damages are presumed, and may be awarded without proof of pecuniary injury. A showing of actual malice is apparently a prerequisite to recovery of punitive damages, and the defendant may in any event forestall a punitive award by a retraction meeting the statutory requirements. Good motives and belief in truth do not negate an inference of malice, but are relevant only in mitigation of punitive damages if the jury chooses to accord them weight. [c]

The question before us is whether this rule of liability, as applied to an action brought by a public official against critics of his official conduct, abridges the freedom of speech and of the press that is guaranteed by the First and Fourteenth Amendments. [Editor’s note: much of the discussion of the Fourteenth Amendment is omitted throughout the opinion.]

Respondent relies heavily, as did the Alabama courts, on statements of this Court to the effect that the Constitution does not protect libelous publications. [fn] Those statements do not foreclose our inquiry here. None of the cases sustained the use of libel laws to impose sanctions upon expression critical of the official conduct of public officials. [***] In the only previous case that did present the question of constitutional limitations upon the power to award damages for libel of a public official, the Court was equally divided and the question was not decided. [c] In deciding the question now, we are compelled by neither precedent nor policy to give any more weight to the epithet ‘libel’ than we have to other ‘mere labels’ of state law. [c] Like insurrection, [fn] contempt, [fn] advocacy of unlawful acts [fn], breach of the peace [fn], obscenity [fn], solicitation of legal business [fn], and the various other formulae for the repression of expression that have been challenged in this Court, libel can claim no talismanic immunity from constitutional limitations. It must be measured by standards that satisfy the First Amendment.

The general proposition that freedom of expression upon public questions is secured by the First Amendment has long been settled by our decisions. The constitutional safeguard, we have said, ‘was fashioned to assure unfettered interchange of ideas for the bringing about of political and social changes desired by the people.’ [c] ‘The maintenance of the opportunity for free political discussion to the end that government may be responsive to the will of the people and that changes may be obtained by lawful means, an opportunity essential to the security of the Republic, is a fundamental principle of our constitutional system.’ [c] ‘(I)t is a prized American privilege to speak one’s mind, although not always with perfect good taste, on all public institutions,’ [c] and this opportunity is to be afforded for ‘vigorous advocacy’ no less than ‘abstract discussion.’ [c]

The First Amendment, said Judge Learned Hand, ‘presupposes that right conclusions are more likely to be gathered out of a multitude of tongues, than through any kind of authoritative selection. To many this is, and always will be, folly; but we have staked upon it our all.’ *United States v. Associated Press*, 52 F. Supp. 362, 372 (D.C.S.D.N.Y.1943). Mr. Justice Brandeis, in his concurring opinion in *Whitney v. California*, 274 U.S. 357, 375—376, gave the principle its classic formulation:

‘Those who won our independence believed * * * that public discussion is a political duty; and that this should be a fundamental principle of the American government. They recognized the risks to which all human institutions are subject. But they knew that order cannot be secured merely through fear of punishment for its infraction; that it is hazardous to discourage thought, *721 hope and imagination; that fear breeds repression; that repression breeds hate; that hate menaces stable government; that the path of safety lies in the opportunity to discuss freely supposed grievances and proposed remedies; and that the fitting remedy for evil counsels is good ones. Believing in the power of reason as applied through public discussion, they eschewed silence coerced by law—the argument of force in its worst form. Recognizing the occasional tyrannies of governing majorities, they amended the Constitution so that free speech and assembly should be guaranteed.’

Thus we consider this case against the background of a profound national commitment to the principle that debate on public issues should be uninhibited, robust, and wide-open, and that it may well include vehement, caustic, and sometimes unpleasantly sharp attacks on government and public officials. [cc] The present advertisement, as an expression of grievance and protest on one of the major public issues of our time, would seem clearly to qualify for the constitutional protection. The question is whether it forfeits that protection by the falsity of some of its factual statements and by its alleged defamation of respondent.

Authoritative interpretations of the First Amendment guarantees have consistently refused to recognize an exception for any test of truth—whether administered by judges, juries, or administrative officials—and especially one that puts the burden of proving truth on the speaker. [c] The constitutional protection does not turn upon ‘the truth, popularity, or social utility of the ideas and beliefs which are offered.’ [c] As Madison said, ‘Some degree of abuse is inseparable from the proper use of everything; and in no instance is this more true than in that of the press.’ [c] [***]

That erroneous statement is inevitable in free debate, and that it must be protected if the freedoms of expression are to have the ‘breathing space’ that they ‘need * * * to survive,’ [c] was also recognized by the Court of Appeals for the District of Columbia Circuit [c]. Judge Edgerton spoke for a unanimous court which affirmed the dismissal of a Congressman’s libel suit based upon a newspaper article charging him with anti-Semitism in opposing a judicial appointment. He said:

‘Cases which impose liability for erroneous reports of the political conduct of officials reflect the obsolete doctrine that the governed must not criticize their governors. * * * The interest of the public here outweighs the interest of appellant *722 or any other individual. The protection of the public requires not merely discussion, but information. Political conduct and views which some respectable people approve, and others condemn, are constantly imputed to Congressmen. Errors of fact, particularly in regard to a man’s mental states and processes, are inevitable. * * * Whatever is added to the field of libel is taken from the field of free debate.’²²²

²²² See also Mill, *On Liberty* (Oxford: Blackwell, 1947), at 47: ‘* * * (T)o argue sophistically, to suppress facts or arguments, to misstate the elements of the case, or misrepresent the opposite opinion * * * all this, even to the most aggravated degree, is so continually done in perfect good faith, by persons who are not considered, and in many other respects may not deserve to be considered, ignorant or incompetent, that it is rarely possible, on adequate grounds,

Injury to official reputation error affords no more warrant for repressing speech that would otherwise be free than does factual error. Where judicial officers are involved, this Court has held that concern for the dignity and ***273** reputation of the courts does not justify the punishment as criminal contempt of criticism of the judge or his decision. [c] This is true even though the utterance contains ‘half-truths’ and ‘misinformation.’ [c] Such repression can be justified, if at all, only by a clear and present danger of the obstruction of justice. [cc] If judges are to be treated as ‘men of fortitude, able to thrive in a hardy climate,’ [c] surely the same must be true of other government officials, such as elected city commissioners.²²³ Criticism of their official conduct does not lose its constitutional protection merely because it is effective criticism and hence diminishes their official reputations.

If neither factual error nor defamatory content suffices to remove the constitutional shield from criticism of official conduct, the combination of the two elements is no less inadequate. This is the lesson to be drawn from the great controversy over the Sedition Act of 1798, 1 Stat. 596, which first crystallized a national awareness of the central meaning of the First Amendment.

[The Court discusses the Sedition Act of 1798, which made it a crime, punishable by a \$5,000 fine and five years in prison, ‘if any person shall write, print, utter or publish * * * any false, scandalous and malicious writing or writings against the government of the United States, or either house of the Congress * * *, or the President * * *, with intent to defame * * * or to bring them, or either of them, into contempt or disrepute; or to excite against them, or either or any of them, the hatred of the good people of the United States.’ The Act expired in 1801, but the Court concludes here that it was unconstitutional.]

What a State may not constitutionally bring about by means of a criminal statute is likewise beyond the reach of its civil law of libel. [fn] The fear of damage awards under a rule such as that invoked by the Alabama courts here may be markedly more inhibiting than the fear of prosecution under a criminal statute. [c] Alabama, for example, has a criminal libel law which subjects to prosecution ‘any person who speaks, writes, or prints of and concerning another any accusation falsely and maliciously importing the commission by such person of a felony, or any other indictable offense involving moral turpitude,’ and which allows as punishment upon conviction a fine not exceeding \$500 and a prison sentence of six months. Alabama Code, Tit. 14, s 350. Presumably a person charged with violation of this statute enjoys ordinary criminal-law safeguards such as the requirements of an indictment and of proof beyond a reasonable doubt. These safeguards are not available to the defendant in a civil action.

The judgment awarded in this case—without the need for any proof of actual pecuniary loss—was one thousand times greater than the maximum fine provided by the Alabama criminal statute, and one hundred times greater than that provided by the Sedition Act. And since there is no double-jeopardy limitation applicable to civil ***725** lawsuits, this is not the only judgment that may be awarded against petitioners for the same publication.²²⁴ Whether or not a newspaper can survive a succession of such

conscientiously to stamp the misrepresentation as morally culpable; and still less could law presume to interfere with this kind of controversial misconduct.’

²²³ The climate in which public officials operate, especially during a political campaign, has been described by one commentator in the following terms: ‘Charges of gross incompetence, disregard of the public interest, communist sympathies, and the like usually have filled the air; and hints of bribery, embezzlement, and other criminal conduct are not infrequent.’ Noel, *Defamation of Public Officers and Candidates*, 49 Col. L. Rev. 875 (1949).

²²⁴ The Times states that four other libel suits based on the advertisement have been filed against it by others who have served as Montgomery City Commissioners and by the Governor of Alabama; that another \$500,000 verdict has been

judgments, the pall of fear and timidity imposed upon those who would give voice to public criticism is an atmosphere in which the First Amendment freedoms cannot survive. Plainly the Alabama law of civil libel is ‘a form of regulation that creates hazards to protected freedoms markedly greater than those that attend reliance upon the criminal law.’ [c]

The state rule of law is not saved by its allowance of the defense of truth. A defense for erroneous statements honestly made is no less essential here than was the requirement of proof of guilty knowledge which, in *Smith v. California*, 361 U.S. 147, we held indispensable to a valid conviction of a bookseller for possessing obscene writings for sale. We said:

‘For if the bookseller is criminally liable without knowledge of the contents, * * * he will tend to restrict the books he sells to those he has inspected; and thus the State will have imposed a restriction upon the distribution of constitutionally protected as well as obscene literature. * * * And the bookseller’s burden would become the public’s burden, for by restricting him the public’s access to reading matter would be restricted. * * * (H)is timidity in the face of his absolute criminal liability, thus would tend to restrict the public’s access to forms of the printed word which the State could not constitutionally * suppress directly. The bookseller’s self-censorship, compelled by the State, would be a censorship affecting the whole public, hardly less virulent for being privately administered. Through it, the distribution of all books, both obscene and not obscene, would be impeded.’ [c]

A rule compelling the critic of official conduct to guarantee the truth of all his factual assertions—and to do so on pain of libel judgments virtually unlimited in amount—leads to a comparable ‘self-censorship.’ Allowance of the defense of truth, with the burden of proving it on the defendant, does not mean that only false speech will be deterred.²²⁵ Even courts accepting this defense as an adequate safeguard have recognized the difficulties of adducing legal proofs that the alleged libel was true in all its factual particulars. [cc] Under such a rule, would-be critics of official conduct may be deterred from voicing their criticism, even though it is believed to be true and even though it is in fact true, because of doubt whether it can be proved in court or fear of the expense of having to do so. They tend to make only statements which ‘steer far wider of the unlawful zone.’ [c] The rule thus dampens the vigor and limits the variety of public debate. It is ***726** inconsistent with the First and Fourteenth Amendments.

The constitutional guarantees require, we think, a federal rule that prohibits a public official from recovering damages for a defamatory falsehood relating to his official conduct unless he proves that the statement was made with ‘actual malice’—that is, with knowledge that it was false or with reckless disregard of whether it was false or not. An oft-cited statement of a like rule, which has been adopted by a number of state courts, [fn] is found in the Kansas case of *Coleman v. MacLennan*, 78 Kan. 711 (1908). The State Attorney General, a candidate for re-election and a member of the commission charged with the management and control of the state school fund, sued a newspaper publisher for alleged libel in an article purporting to state facts relating to his official conduct in connection with a

awarded in the only one of these cases that has yet gone to trial; and that the damages sought in the other three total \$2,000,000.

²²⁵ Even a false statement may be deemed to make a valuable contribution to public debate, since it brings about ‘the clearer perception and livelier impression of truth, produced by its collision with error.’ Mill, *On Liberty* (Oxford: Blackwell, 1947), at 15; see also Milton, *Areopagitica*, in *Prose Works* (Yale, 1959), Vol. II, at 561.

school-fund transaction. The defendant pleaded privilege and the trial judge, over the plaintiff's objection, instructed the jury that

'where an article is published and circulated among voters for the sole purpose of giving what the defendant * believes to be truthful information concerning a candidate for public office and for the purpose of enabling such voters to cast their ballot more intelligently, and the whole thing is done in good faith and without malice, the article is privileged, although the principal matters contained in the article may be untrue in fact and derogatory to the character of the plaintiff; and in such a case the burden is on the plaintiff to show actual malice in the publication of the article.'

In answer to a special question, the jury found that the plaintiff had not proved actual malice, and a general verdict was returned for the defendant. On appeal the Supreme Court of Kansas, in an opinion by Justice Burch, reasoned as follows (78 Kan., at 724, 98 P., at 286):

'(I)t is of the utmost consequence that the people should discuss the character and qualifications of candidates for their suffrages. The importance to the state and to society of such discussions is so vast, and the advantages derived are so great that they more than counterbalance the inconvenience of private persons whose conduct may be involved, and occasional injury to the reputations of individuals must yield to the public welfare, although at times such injury may be great. The *727 public benefit from publicity is so great and the chance of injury to private character so small that such discussion must be privileged.'

The court thus sustained the trial court's instruction as a correct statement of the law, saying:

'In such a case the occasion gives rise to a privilege qualified to this extent. Anyone claiming to be defamed by the communication must show actual malice, or go remediless. This privilege extends to a great variety of subjects and includes matters of * public concern, public men, and candidates for office.' [c]

Such a privilege for criticism of official conduct²²⁶ is appropriately analogous to the protection accorded a public official when he is sued for libel by a private citizen. In *Barr v. Matteo*, 360 U.S. 564, 575, this Court held the utterance of a federal official to be absolutely privileged if made 'within the outer perimeter' of his duties. The States accord the same immunity to statements of their highest officers, although some differentiate their lesser officials and qualify the privilege they enjoy. [fn] But all hold that all officials are protected unless actual malice can be proved. The reason for the official privilege is said to be that the threat of damage suits would otherwise 'inhibit the fearless, vigorous, and effective administration of policies of government' and 'dampen the ardor of all but the most resolute, or the most irresponsible, in the unflinching discharge of their duties.' [c]

Analogous considerations support the privilege for the citizen-critic of government. It is as much his duty to criticize as it is the official's duty to administer. [c] As Madison said, see *supra*, p. 723, 'the censorial power is in the people over the Government, and not in the Government over the people.' It

²²⁶ The privilege immunizing honest misstatements of fact is often referred to as a 'conditional' privilege to distinguish it from the 'absolute' privilege recognized in judicial, legislative, administrative and executive proceedings. See, e.g., Prosser, *Torts* (2d ed., 1955), s 95.

would give public servants an unjustified preference over the public they serve, if critics of official conduct did not have a fair equivalent of the immunity granted to the officials themselves.

We conclude that such a privilege is required by the First and Fourteenth Amendments.

We hold today that the Constitution delimits a State's power to award damages for libel in actions brought by public officials against critics of their official conduct. Since this is such an action,²²⁷ the rule requiring proof of actual malice is applicable. While *728 Alabama law apparently requires proof of actual malice for an award of punitive damages,²²⁸ where general damages are concerned malice is 'presumed.' Such a presumption is inconsistent with the federal rule. 'The power to create presumptions is not a means of escape from constitutional restrictions,' [c]; '(t)he showing of malice required for the forfeiture of the privilege is not presumed but is a matter for proof by the plaintiff * * *.' [c] Since the trial judge did not instruct the jury to differentiate between general and punitive damages, it may be that the verdict was wholly an award of one or the other. But it is impossible to know, in view of the general verdict returned. Because of this uncertainty, the judgment must be reversed and the case remanded. [cc]

Since respondent may seek a new trial, we deem that considerations of effective judicial administration require us to review the evidence in the present record to determine whether it could constitutionally support a judgment for respondent. This Court's duty is not limited to the elaboration of constitutional principles; we must also in proper cases review the evidence to make certain that those principles have

²²⁷ We have no occasion here to determine how far down into the lower ranks of government employees the 'public official' designation would extend for purposes of this rule, or otherwise to specify categories of persons who would or would not be included. ... Nor need we here determine the boundaries of the 'official conduct' concept. It is enough for the present case that respondent's position as an elected city commissioner clearly made him a public official, and that the allegations in the advertisement concerned what was allegedly his official conduct as Commissioner in charge of the Police Department. As to the statements alleging the assaulting of Dr. King and the bombing of his home, it is immaterial that they might not be considered to involve respondent's official conduct if he himself had been accused of perpetrating the assault and the bombing. Respondent does not claim that the statements charged him personally with these acts; his contention is that the advertisement connects him with them only in his official capacity as the Commissioner supervising the police, on the theory that the police might be equated with the 'They' who did the bombing and assaulting. Thus, if these allegations can be read as referring to respondent at all, they must be read as describing his performance of his official duties.

²²⁸ *Johnson Publishing Co. v. Davis*, 271 Ala. 474, 487 (1960). Thus, the trial judge here instructed the jury that 'mere negligence or carelessness is not evidence of actual malice or malice in fact, and does not justify an award of exemplary or punitive damages in an action for libel.' The court refused, however, to give the following instruction which had been requested by the Times:

'I charge you * * * that punitive damages, as the name indicates, are designed to punish the defendant, the New York Times Company, a corporation, and the other defendants in this case, * * * and I further charge you that such punitive damages may be awarded only in the event that you, the jury, are convinced by a fair preponderance of the evidence that the defendant * * * was motivated by personal illwill [sic], that is actual intent to do the plaintiff harm, or that the defendant * * * was guilty of gross negligence and recklessness and not of just ordinary negligence or carelessness in publishing the matter complained of so as to indicate a wanton disregard of plaintiff's rights.'

The trial court's error in failing to require any finding of actual malice for an award of general damages makes it unnecessary for us to consider the sufficiency under the federal standard of the instructions regarding actual malice that were given as to punitive damages.

been constitutionally applied. This is such a case, particularly since the question is one of alleged trespass across ‘the line between speech unconditionally guaranteed and speech which may legitimately be regulated.’ [c] [***]

Applying these standards, we consider that the proof presented to show actual malice lacks the convincing clarity which the constitutional standard demands, and hence that it would not constitutionally sustain the judgment for respondent under the proper rule of law. The case of the individual petitioners requires little discussion. Even assuming that they could constitutionally be found to have authorized the use of their names on the advertisement, there was no evidence whatever that they were aware of any erroneous statements or were in any way reckless in that regard. The judgment against them is thus without constitutional support.

As to the Times, we similarly conclude that the facts do not support a finding of actual malice. The statement by the Times’ Secretary that, apart from the padlocking allegation, he thought the advertisement was ‘substantially correct,’ affords no constitutional warrant for the Alabama Supreme Court’s conclusion that it was a ‘cavalier ignoring of the falsity of the advertisement (from which), the jury could not have but been impressed with the bad faith of The Times, and its maliciousness inferable therefrom.’ The statement does not indicate malice at the time of the publication; even if the advertisement was not ‘substantially correct’—although respondent’s own proofs tend to show that it was—that opinion was at least a reasonable one, and there was no evidence to impeach the witness’ good faith in holding it. The Times’ failure to retract upon respondent’s demand, although it later retracted upon the demand of Governor Patterson, is likewise not adequate evidence of malice for constitutional purposes. Whether or not a failure to retract may ever constitute such evidence, there are two reasons why it does not here.

First, the letter written by the Times reflected a reasonable doubt on its part as to whether the advertisement could reasonably be taken to refer to respondent at all. Second, it was not a final refusal, since it asked for an explanation on this point—a request that respondent chose to ignore. Nor does the retraction upon the demand of the Governor supply the necessary proof. It may be doubted that a failure to retract which is not itself evidence of malice can retroactively become such by virtue of a retraction subsequently made to another party. But in any event that did not happen here, since the *730 explanation given by the Times’ Secretary for the distinction drawn between respondent and the Governor was a reasonable one, the good faith of which was not impeached.

Finally, there is evidence that the Times published the advertisement without checking its accuracy against the news stories in the Times’ own files. The mere presence of the stories in the files does not, of course, establish that the Times ‘knew’ the advertisement was false, since the state of mind required for actual malice would have to be brought home to the persons in the Times’ organization having responsibility for the publication of the advertisement. With respect to the failure of those persons to make the check, the record shows that they relied upon their knowledge of the good reputation of many of those whose names were listed as sponsors of the advertisement, and upon the letter from A. Philip Randolph, known to them as a responsible individual, certifying that the use of the names was authorized. There was testimony that the persons handling the advertisement saw nothing in it that would render it unacceptable under the Times’ policy of rejecting advertisements containing ‘attacks

of a personal character’;²²⁹ their failure to reject it on this ground was not unreasonable. We think the evidence against the Times supports at most a finding of negligence in failing to discover the misstatements, and is constitutionally insufficient to show the recklessness that is required for a finding of actual malice. [cc]

We also think the evidence was constitutionally defective in another respect: it was incapable of supporting the jury’s finding that the allegedly libelous statements were made ‘of and concerning’ respondent. Respondent relies on the words of the advertisement and the testimony of six witnesses to establish a connection between it and himself. Thus, in his brief to this Court, he states:

‘The reference to respondent as police commissioner is clear from the ad. In addition, the jury heard the testimony of a newspaper editor * * *; a real estate and insurance man * * *; the sales manager of a men’s clothing store * * *; a food equipment man * * *; a service station operator * * *; and the operator of a truck line for whom respondent had formerly worked * * *. Each of these witnesses stated that he associated the statements with respondent * * *.’ (Citations to record omitted.)

There was no reference to respondent in the advertisement, either by name or official position. A number of the allegedly libelous statements—the charges that the dining hall was padlocked and that Dr. King’s home was bombed, his person assaulted, and a perjury prosecution instituted against him—did not even concern the police; despite the ingenuity of the arguments which would attach this significance to the word ‘They,’ it is plain that these statements could not reasonably be read as accusing respondent of personal involvement in the acts in question. The statements upon which respondent *731 principally relies as referring to him are the two allegations that did concern the police or police functions: that ‘truckloads of police * * * ringed the Alabama State College Campus’ after the demonstration on the State Capitol steps, and that Dr. King had been arrested * * * seven times.’ These statements were false only in that the police had been ‘deployed near’ the campus but had not actually ‘ringed’ it and had not gone there in connection with the State Capitol demonstration, and in that Dr. King had been arrested only four times. The ruling that these discrepancies between what was true and what was asserted were sufficient to injure respondent’s reputation may itself raise constitutional problems, but we need not consider them here.

Although the statements may be taken as referring to the police, they did not on their face make even an oblique reference to respondent as an individual. Support for the asserted reference must, therefore, be sought in the testimony of respondent’s witnesses. But none of them suggested any basis for the belief that respondent himself was attacked in the advertisement beyond the bare fact that he was in overall charge of the Police Department and thus bore official responsibility for police conduct; to the extent that some of the witnesses thought respondent to have been charged with ordering or approving the conduct or otherwise being personally involved in it, they based this notion not on any statements in the advertisement, and not on any evidence that he had in fact been so involved, but solely on the

²²⁹ The Times has set forth in a booklet its ‘Advertising Acceptability Standards.’ Listed among the classes of advertising that the newspaper does not accept are advertisements that are ‘fraudulent or deceptive,’ that are ‘ambiguous in wording and * * * may mislead,’ and that contain ‘attacks of a personal character.’ In replying to respondent’s interrogatories before the trial, the Secretary of the Times stated that ‘as the advertisement made no attacks of a personal character upon any individual and otherwise met the advertising acceptability standards promulgated,’ it had been approved for publication.

unsupported assumption that, because of his official position, he must have been.²³⁰ This reliance on the bare fact of respondent's ***732** official position [fn] was made explicit by the Supreme Court of Alabama. That court, in holding that the trial court 'did not err in overruling the demurrer (of the Times) in the aspect that the libelous matter was not of and concerning the (plaintiff,)' based its ruling on the proposition that:

'We think it common knowledge that the average person knows that municipal agents, such as police and firemen, and others, are under the control and direction of the city governing body, and more particularly under the direction and control of a single commissioner. In measuring the performance or deficiencies of such groups, praise or criticism is usually attached to the official in complete control of the body.' 273 Ala., at 674—675.

This proposition has disquieting implications for criticism of governmental conduct. For good reason, 'no court of last resort in this country has ever held, or even suggested, that prosecutions for libel on government have any place in the American system of jurisprudence.' *City of Chicago v. Tribune Co.*, 307 Ill. 595, 601 (1923).

The present proposition would sidestep this obstacle by transmuted criticism of government, however impersonal it may seem on its face, into personal criticism, and hence potential libel, of the officials of whom the government is composed. There is no legal alchemy by which a State may thus create the cause of action that would otherwise be denied for a publication which, as respondent himself said of the advertisement, 'reflects not only on me but on the other Commissioners and the community.' Raising as it does the possibility that a good-faith critic of government will be penalized for his criticism, the proposition relied on by the Alabama courts strikes at the very center of the constitutionally protected area of free expression.²³¹

We hold that such a proposition may not constitutionally be utilized to establish that an otherwise impersonal attack on governmental operations was a libel of an official responsible for those operations. Since it was relied on exclusively here, and there was no other evidence to connect the statements with respondent, the evidence was constitutionally insufficient to support a finding that the statements referred to respondent.

***733** The judgment of the Supreme Court of Alabama is reversed and the case is remanded to that court for further proceedings not inconsistent with this opinion.

²³⁰ Respondent's own testimony was that 'as Commissioner of Public Affairs it is part of my duty to supervise the Police Department and I certainly feel like it (a statement) is associated with me when it describes police activities.' He thought that 'by virtue of being Police Commissioner and Commissioner of Public Affairs,' he was charged with 'any activity on the part of the Police Department.' 'When it describes police action, certainly I feel it reflects on me as an individual.' He added that 'It is my feeling that it reflects not only on me but on the other Commissioners and the community.'

²³¹ Insofar as the proposition means only that the statements about police conduct libeled respondent by implicitly criticizing his ability to run the Police Department, recovery is also precluded in this case by the doctrine of fair comment. See American Law Institute, *Restatement of Torts* (1938), s 607. Since the Fourteenth Amendment requires recognition of the conditional privilege for honest misstatements of fact, it follows that a defense of fair comment must be afforded for honest expression of opinion based upon privileged, as well as true, statements of fact. Both defenses are of course defeasible if the public official proves actual malice, as was not done here.

Reversed and remanded.

Concurrence of Justice Black, joined by Justice Douglas

I concur in reversing this half-million-dollar judgment against the New York Times Company and the four individual defendants. In reversing the Court holds that 'the Constitution delimits a State's power to award damages for libel in actions brought by public officials against critics of their official conduct.' Ante, p. 727. I base my vote to reverse on the belief that the First and Fourteenth Amendments do not merely 'delimit' a State's power to award damages to 'public officials against critics of their official conduct' but completely prohibit a State from exercising such a power. The Court goes on to hold that a State can subject such critics to damages if 'actual malice' can be proved against them.

'Malice,' even as defined by the Court, is an elusive, abstract concept, hard to prove and hard to disprove. The requirement that malice be proved provides at best an evanescent protection for the right critically to discuss public affairs and certainly does not measure up to the sturdy safeguard embodied in the First Amendment. Unlike the Court, therefore, I vote to reverse exclusively on the ground that the Times and the individual defendants had an absolute, unconditional constitutional right to publish in the Times advertisement their criticisms of the Montgomery agencies and officials. I do not base my vote to reverse on any failure to prove that these individual defendants signed the advertisement or that their criticism of the Police Department was aimed at the plaintiff Sullivan, who was then the Montgomery City Commissioner having supervision of the City's police; for present purposes I assume these things were proved. Nor is my reason for reversal the size of the half-million-dollar judgment, large as it is. If Alabama has constitutional power to use its civil libel law to impose damages on the press for criticizing the way public officials perform or fail to perform their duties, I know of no provision in the Federal Constitution which either expressly or impliedly bars the State from fixing the amount of damages.

The half-million-dollar verdict does give dramatic proof, however, that state libel laws threaten the very existence of an American press virile enough to publish unpopular views on public affairs and bold enough to criticize the conduct of public officials. The factual background of this case emphasizes the imminence and enormity of that threat. One of the acute and highly emotional issues in this country arises out of efforts of many people, even including some public officials, to continue state-commanded segregation of races in the public schools and other public places, despite our several holdings that such a state practice is forbidden by the Fourteenth Amendment.

Montgomery is one of the localities in which widespread hostility to desegregation has been manifested. This hostility has sometimes extended itself to persons who favor desegregation, particularly to so-called 'outside agitators,' a term which can be made to fit papers like the Times, which is published in New York. The scarcity of testimony to show that Commissioner Sullivan suffered any actual damages at all suggests that these feelings of hostility had at least as much to do with rendition of this half-million-dollar verdict as did an appraisal of damages. Viewed realistically, this record lends support to an inference that instead of being damaged Commissioner Sullivan's political, social, and financial prestige has likely been enhanced by the Times' publication. Moreover, a second half-million-dollar libel verdict against the Times based on the same advertisement has already been *734 awarded to another Commissioner.

There a jury again gave the full amount claimed. There is no reason to believe that there are not more such huge verdicts lurking just around the corner for the Times or any other newspaper or broadcaster which might dare to criticize public officials. In fact, briefs before us show that in Alabama there are now pending eleven libel suits by local and state officials against the Times seeking \$5,600,000, and five such suits against the Columbia Broadcasting System seeking \$1,700,000. Moreover, this technique for harassing and punishing a free press—now that it has been shown to be possible—is by no means limited to cases with racial overtones; it can be used in other fields where public feelings may make local as well as out-of-state newspapers easy prey for libel verdict seekers.

In my opinion the Federal Constitution has dealt with this deadly danger to the press in the only way possible without leaving the free press open to destruction—by granting the press an absolute immunity for criticism of the way public officials do their public duty. [c] Stopgap measures like those the Court adopts are in my judgment not enough. This record certainly does not indicate that any different verdict would have been rendered here whatever the Court had charged the jury about ‘malice,’ ‘truth,’ ‘good motives,’ ‘justifiable ends,’ or any other legal formulas which in theory would protect the press. Nor does the record indicate that any of these legalistic words would have caused the courts below to set aside or to reduce the half-million-dollar verdict in any amount. [***]

We would, I think, more faithfully interpret the First Amendment by holding that at the very least it leaves the people and the press free to criticize officials and discuss public affairs with impunity. This Nation of our elects many of its important officials; so do the States, the municipalities, the counties, and even many precincts. These officials are responsible to the people for the way they perform their duties. While our Court has held that some kinds of speech and writings, such as ‘obscenity,’ *735 *Roth v. United States*, 354 U.S. 476, and ‘fighting words,’ *Chaplinsky v. New Hampshire*, 315 U.S. 568, are not expression within the protection of the First Amendment [c], freedom to discuss public affairs and public officials is unquestionably, as the Court today holds, the kind of speech the First Amendment was primarily designed to keep within the area of free discussion. To punish the exercise of this right to discuss public affairs or to penalize it through libel judgments is to abridge or shut off discussion of the very kind most needed.

This Nation, I suspect, can live in peace without libel suits based on public discussions of public affairs and public officials. But I doubt that a country can live in freedom where its people can be made to suffer physically or financially for criticizing their government, its actions, or its officials. ‘For a representative democracy ceases to exist the moment that the public functionaries are by any means absolved from their responsibility to their constituents; and this happens whenever the constituent can be restrained in any manner from speaking, writing, or publishing his opinions upon any public measure, or upon the conduct of those who may advise or execute it.’²³² An unconditional right to say what one pleases about public affairs is what I consider to be the minimum guarantee of the First Amendment. [fn] I regret that the Court has stopped short of this holding indispensable to preserve our free press from destruction.

Concurrence by Justice Goldberg, joined by Justice Douglas

²³² 1 Tucker, *Blackstone’s Commentaries* (1803), 297 (editor’s appendix; cf. Brant, *Seditious Libel: Myth and Reality*, 39 *N.Y.U.L. Rev.* 1.

The Court today announces a constitutional standard which prohibits ‘a public official from recovering damages for a defamatory falsehood relating to his official conduct unless he proves that the statement was made with ‘ACTUAL MALICE’—THAT IS, WITH KNOWLEDGE that it was false or with reckless disregard of whether it was false or not.’ Ante, at p. 726. The Court thus rules that the Constitution gives citizens and newspapers a ‘conditional privilege’ immunizing nonmalicious misstatements of fact regarding the official conduct of a government officer. The impressive array of history²³³ and precedent marshaled by the Court, however, confirms my belief that the Constitution affords greater protection than that provided by the Court’s standard to citizen and press in exercising the right of public criticism.

In my view, the First and Fourteenth Amendments to the Constitution afford to the citizen and to the press an absolute, unconditional privilege to criticize official conduct despite the harm which may flow from excesses and abuses. The prized American right ‘to speak one’s *736 mind,’ [c] about public officials and affairs needs ‘breathing space to survive,’ [c]. The right should not depend upon a probing by the jury of the motivation²³⁴ of the citizen or press. The theory of our Constitution is that every citizen may speak his mind and every newspaper express its view on matters of public concern and may not be barred from speaking or publishing because those in control of government think that what is said or written is unwise, unfair, false, or malicious. In a democratic society, one who assumes to act for the citizens in an executive, legislative, or judicial capacity must expect that his official acts will be commented upon and criticized. Such criticism cannot, in my opinion, be muzzled or deterred by the courts at the instance of public officials under the label of libel.

It has been recognized that ‘prosecutions for libel on government have (no) place in the American system of jurisprudence.’ *City of Chicago v. Tribune Co.*, 307 Ill. 595, 601. I fully agree. Government, however, is not an abstraction; it is made up of individuals—of governors responsible to the governed. In a democratic society where men are free by ballots to remove those in power, any statement critical of governmental action is necessarily ‘of and concerning’ the governors and any statement critical of the governors’ official conduct is necessarily ‘of and concerning’ the government. If the rule that libel on government has no place in our Constitution is to have real meaning, then libel on the official conduct of the governors likewise can have no place in our Constitution.

We must recognize that we are writing upon a clean slate.²³⁵ As the Court notes, although there have been ‘statements of this Court to the effect that the Constitution does not protect libelous publications * * * (n)one of the cases sustained the use of libel laws to impose sanctions upon expression critical of the official conduct of public officials.’ Ante, at p. 719. *737 [***]

²³³ I fully agree with the Court that the attack upon the validity of the Sedition Act of 1798, 1 Stat. 596 ‘has carried the day in the court of history,’ ante, at p. 723, and that the Act would today be declared unconstitutional. It should be pointed out, however, that the Sedition Act proscribed writings which were ‘false, scandalous and malicious.’

²³⁴ The requirement of proving actual malice or reckless disregard may, in the mind of the jury, add little to the requirement of proving falsity, a requirement which the Court recognizes not to be an adequate safeguard.

²³⁵ It was not until *Gitlow v. New York*, 268 U.S. 652, decided in 1925, that it was intimated that the freedom of speech guaranteed by the First Amendment was applicable to the States by reason of the Fourteenth Amendment. Other intimations followed. See *Whitney v. California*, 274 U.S. 357; *Fiske v. Kansas*, 274 U.S. 380. In 1931 Chief Justice Hughes speaking for the Court in *Stromberg v. California*, 283 U.S. 359, 368, declared: ‘It has been determined that the conception of liberty under the due process clause of the Fourteenth Amendment embraces the right of free speech.’ Thus we deal with a constitutional principle enunciated less than four decades ago, and consider for the first time the application of that principle to issues arising in libel cases brought by state officials.

[The real issue here] is whether that freedom of speech which all agree is constitutionally protected can be effectively safeguarded by a rule allowing the imposition of liability upon a jury's evaluation of the speaker's state of mind. If individual citizens may be held liable in damages for strong words, which a jury finds false and maliciously motivated, there can be little doubt that public debate and advocacy will be constrained. And if newspapers, publishing advertisements dealing with public issues, thereby risk liability, there can also be little doubt that the ability of minority groups to secure publication of their views on public affairs and to seek support for their causes will be greatly diminished. [c] The opinion of the Court conclusively demonstrates the chilling effect of the Alabama libel laws on First Amendment freedoms in the area of race relations. [***]To impose liability for critical, albeit erroneous or even malicious, comments on official conduct would effectively resurrect 'the obsolete doctrine that the governed must not criticize their governors.' [c]

Our national experience teaches that repressions breed hate and 'that hate menaces stable government.' [c]. We should be ever mindful of the wise counsel of Chief Justice Hughes:

'(I)mperative is the need to preserve inviolate the constitutional rights of free speech, free press and free assembly in order to maintain the opportunity for free political discussion, to the end that government may be responsive to the will of the people and that changes, if desired, may be obtained by peaceful means. Therein lies the security of the Republic, the very foundation of constitutional government.' [c]

This is not to say that the Constitution protects defamatory statements directed against the private conduct of a public official or private citizen. Freedom of press and of speech ensures that government will respond to the will of the people and that changes may be obtained by peaceful means. [c] [***] The imposition of liability for private defamation does not abridge the freedom of public speech or any other freedom protected by the First Amendment.²³⁶ This, of course, cannot be said 'where *738 public officials are concerned or where public matters are involved. * * * (O)ne main function of the First Amendment is to ensure ample opportunity for the people to determine and resolve public issues. Where public matters are involved, the doubts should be resolved in favor of freedom of expression rather than against it.' Douglas, *The Right of the People* (1958), p. 41.

In many jurisdictions, legislators, judges and executive officers are clothed with absolute immunity against liability for defamatory words uttered in the discharge of their public duties. [c]

Judge Learned Hand ably summarized the policies underlying the rule:

'It does indeed go without saying that an official, who is in fact guilty of using his powers to vent his spleen upon others, or for any other personal motive not connected with the public good, should not escape liability for the injuries he may so cause; and, if it were possible in practice to confine such complaints to the guilty, it would be monstrous to deny recovery. The justification for doing so is that it is impossible to know whether the claim is well founded until the case has been tried, and that to submit

²³⁶ In most cases, as in the case at bar, there will be little difficulty in distinguishing defamatory speech relating to private conduct from that relating to official conduct. I recognize, of course, that there will be a gray area. The difficulties of applying a public-private standard are, however, certainly, of a different genre from those attending the differentiation between a malicious and nonmalicious state of mind. If the constitutional standard is to be shaped by a concept of malice, the speaker takes the risk not only that the jury will inaccurately determine his state of mind but also that the injury will fail properly to apply the constitutional standard set by the elusive concept of malice.

all officials, the innocent as well as the guilty, to the burden of a trial and to the inevitable danger of its outcome, would dampen the ardor of all but the most resolute, or the most irresponsible, in the unflinching discharge of their duties. Again and again the public interest calls for action which may turn out to be founded on a mistake, in the face of which an official may later find himself hard put to it to satisfy a jury of his good faith. There must indeed be means of punishing public officers who have been truant to their duties; but that is quite another matter from exposing such as have been honestly mistaken to suit by anyone who has suffered from their errors. As is so often the case, the answer must be found in a balance between the evils inevitable in either alternative. In this instance it has been thought in the end better to leave unredressed the wrongs done by dishonest officers than to subject those who try to do their duty to the constant dread of retaliation. * * * [***] [c]

If the government official should be immune from libel actions so that his ardor to serve the public will not be dampened and ‘fearless, vigorous, and effective administration of policies of government’ not be inhibited, [c], then the citizen and the press should likewise be immune from libel actions for their criticism of official conduct. Their ardor as citizens will thus not be dampened and they will *739 be free ‘to applaud or to criticize the way public employees do their jobs, from the least to the most important.’ If liability can attach to political criticism because it damages the reputation of a public official as a public official, then no critical citizen can safely utter anything but faint praise about the government or its officials. The vigorous criticism by press and citizen of the conduct of the government of the day by the officials of the day will soon yield to silence if officials in control of government agencies, instead of answering criticisms, can resort to friendly juries to forestall criticism of their official conduct.

The conclusion that the Constitution affords the citizen and the press an absolute privilege for criticism of official conduct does not leave the public official without defenses against unsubstantiated opinions or deliberate misstatements. ‘Under our system of government, counterargument and education are the weapons available to expose these matters, not abridgment * * * of free speech * * *.’ [c] The public official certainly has equal if not greater access than most private citizens to media of communication. In any event, despite the possibility that some excesses and abuses may go unremedied, we must recognize that ‘the people of this nation have ordained in the light of history, that, in spite of the probability of excesses and abuses, (certain) liberties are, in the long view, essential to enlightened opinion and right conduct on the part of the citizens of a democracy.’ [c] As Mr. Justice Brandeis correctly observed, ‘sunlight is the most powerful of all disinfectants.’

For these reasons, I strongly believe that the Constitution accords citizens and press an unconditional freedom to criticize official conduct. It necessarily follows that in a case such as this, where all agree that the allegedly defamatory statements related to official conduct, the judgments for libel cannot constitutionally be sustained.

Note 1. “Heed Their Rising Voices” is viewable via [Wikipedia](#).

The New York Times.

NEW YORK, TUESDAY, MARCH 29, 1960.

"The growing movement of peaceful mass demonstrations by Negroes is something new in the South, something understandable. . . . Let Congress heed their rising voices, for they will be heard."

—New York Times editorial
Saturday, March 19, 1960

Heed Their Rising Voices

AS the whole world knows by now, thousands of Southern Negro students are engaged in widespread non-violent demonstrations in positive affirmation of the right to live in human dignity as guaranteed by the U. S. Constitution and the Bill of Rights. In their efforts to uphold these guarantees, they are being met by an unprecedented wave of terror by those who would deny and negate that document which the whole world looks upon as setting the pattern for modern freedom. . . .

In Orangeburg, South Carolina, when 400 students peacefully sought to buy doughnuts and coffee at lunch counters in the business district, they were forcibly ejected, tear-gassed, soaked to the skin in freezing weather with fire hoses, arrested en masse and herded into an open barbed-wire stockade to stand for hours in the bitter cold.

In Montgomery, Alabama, after students sang "My Country, 'Tis of Thee" on the State Capitol steps, their leaders were expelled from school, and truckloads of police armed with shotguns and tear-gas ringed the Alabama State College Campus. When the entire student body protested to state authorities by refusing to re-register, their dining hall was padlocked in an attempt to starve them into submission.

In Tallahassee, Atlanta, Nashville, Savannah, Greensboro, Memphis, Richmond, Charlotte, and a host of other cities in the South, young American teenagers, in face of the entire weight of official state apparatus and police power, have boldly stepped forth as

protagonists of democracy. Their courage and amazing restraint have inspired millions and given a new dignity to the cause of freedom.

Small wonder that the Southern violators of the Constitution fear this new, non-violent brand of freedom fighter . . . even as they fear the upswelling right-to-vote movement. Small wonder that they are determined to destroy the one man who, more than any other, symbolizes the new spirit now sweeping the South—the Rev. Dr. Martin Luther King, Jr., world-famous leader of the Montgomery Bus Protest. For it is his doctrine of non-violence which has inspired and guided the students in their widening wave of sit-ins; and it is this same Dr. King who founded and is president of the Southern Christian Leadership Conference—the organization which is spearheading the surging right-to-vote movement. Under Dr. King's direction the Leadership Conference conducts Student Workshops and Seminars in the philosophy and technique of non-violent resistance.

Again and again the Southern violators have answered Dr. King's peaceful protests with intimidation and violence. They have bombed his home almost killing his wife and child. They have assaulted his person. They have arrested him seven times—for "speeding," "loitering" and similar "offenses." And now they have charged him with "perjury"—a felony under which they could imprison him for ten years. Obviously, their real purpose is to remove him physically as the leader to whom the students and millions

of others—look for guidance and support, and thereby to intimidate all leaders who may rise in the South. Their strategy is to behead this affirmative movement, and thus to demoralize Negro Americans and weaken their will to struggle. The defense of Martin Luther King, spiritual leader of the student sit-in movement, clearly, therefore, is an integral part of the total struggle for freedom in the South.

Decent-minded Americans cannot help but applaud the creative daring of the students and the quiet heroism of Dr. King. But this is one of those moments in the stormy history of Freedom when men and women of good will must do more than applaud the rising-to-glory of others. The America whose good name hangs in the balance before a watchful world, the America whose heritage of Liberty these Southern Upholders of the Constitution are defending, is our America as well as theirs. . . .

We must heed their rising voices—yes—but we must add our own.

We must extend ourselves above and beyond moral support and render the material help so urgently needed by those who are taking the risks, facing jail, and even death in a glorious re-affirmation of our Constitution and its Bill of Rights.

We urge you to join hands with our fellow Americans in the South by supporting, with your dollars, this Combined Appeal for all three needs—the defense of Martin Luther King—the support of the embattled students—and the struggle for the right-to-vote.

Your Help Is Urgently Needed . . . NOW !!

Stella Adler
Raymond Pace Alexander
Shelby Apolton
Harry Van Arsdale
Harry Belafonte
Julie Belafonte
Dr. Algenon Black
Marc Bitstein
William Bove
William Branch
Marlon Brando
Mrs. Ralph Bunche
Diabann Canoll
Dr. Alan Knight Chalmers

Joseph Cohen
Richard Cox
Nat King Cole
Cheryl Crawford
Dorothy Dandridge
Ossie Davis
Sammy Davis, Jr.
Ruby Dee
Horry Duff
Scotty Eckford
Dr. Philip Elliott
Dr. Harry Emerson Fosdick

Anthony Franciosa
Matthew Gaisner
Lorraine Hansbury
Rev. Donald Harrington
Nat Hentoff
James Hicks
Mary Hinson
Van Heflin
Langston Hughes
Morris Iushewitz
Mahalia Jackson
Paul Jennings
Mordecai Johnson
John Killens

Eartha Kitt
Rabbi Edward Klein
Hope Lange
John Lewis
Vivica Lindfors
David Livingston
William Michaelson
Carl Murphy
Don Murray
John Murray
A. J. Muste
Frederick O'Neal
Peter Onley
L. Joseph Overton

Albert P. Palmer
Clarence Pickett
Shad Polier
Sidney Poitier
Michael Potoker
A. Philip Randolph
John Raitt
Elmer Rice
Cleveland Robinson
Jackie Robinson
Mrs. Eleanor Roosevelt
Bayard Rustin
Robert Ryan
Maureen Stapleton

Frank Silvera
Louis Simon
Shad Stevens
David Sullivan
Julius Sum
George Tabari
Rev. Gardner C. Taylor
Norman Thomas
Kenneth Tynan
Charles White
Shelley Winters
Max Youngstein

We in the south who are struggling daily for dignity and freedom warmly endorse this appeal

Rev. Ralph D. Abernathy
(Montgomery, Ala.)
Rev. Fred L. Shuttlesworth
(Birmingham, Ala.)
Rev. Kelley Miller Smith
(Nashville, Tenn.)
Rev. W. A. Dennis
(Chattanooga, Tenn.)
Rev. C. K. Steele
(Tallahassee, Fla.)

Rev. Matthew D. McCollom
(Orangeburg, S. C.)
Rev. William Holmes Borders
(Atlanta, Ga.)
Rev. Douglas Moore
(Durham, N. C.)
Rev. Wyatt Tee Walker
(Petersburg, Va.)

Rev. Walter L. Hamilton
(Norfolk, Va.)
I. S. Levy
(Columbia, S. C.)
Rev. Martin Luther King, Sr.
(Atlanta, Ga.)
Rev. Henry C. Buntin
(Memphis, Tenn.)
Rev. S. S. Seay, Sr.
(Montgomery, Ala.)
Rev. Samuel W. Williams
(Atlanta, Ga.)

Rev. A. L. Davis
(New Orleans, La.)
Mrs. Katie E. Whickham
(New Orleans, La.)
Rev. W. H. Hall
(Hattiesburg, Miss.)
Rev. J. E. Lowery
(Mobile, Ala.)
Rev. T. J. Jemison
(Baton Rouge, La.)

COMMITTEE TO DEFEND MARTIN LUTHER KING AND THE STRUGGLE FOR FREEDOM IN THE SOUTH
312 West 125th Street, New York 27, N. Y. UNiversity 6-1700

Chairmen: A. Philip Randolph, Dr. Gardner C. Taylor; Chairmen of Cultural Division: Harry Belafonte, Sidney Poitier; Treasurer: Nat King Cole; Executive Director: Bayard Rustin; Chairmen of Church Division: Father George B. Ford, Rev. Harry Emerson Fosdick, Rev. Thomas Kilgore, Jr., Rabbi Edward E. Klein; Chairmen of Labor Division: Morris Iushewitz, Cleveland Robinson.

Please mail this coupon TODAY!

Committee To Defend Martin Luther King and The Struggle For Freedom In The South

312 West 125th Street, New York 27, N. Y.
UNiversity 6-1700

I am enclosing my contribution of \$ _____
for the work of the Committee.

Name _____
(PLEASE PRINT)

Address _____

City _____ Zone _____ State _____

I want to help Please send further information

Please make checks payable to:

Committee To Defend Martin Luther King

Source: *NY Times Ad*, 3/29/1960

Credit: Public Domain. Reproduction of a copy kept in the archives of the U.S. District Court for the Northern (Montgomery) Division of the Middle District of Alabama.

Note 2. Political or Ideological Arguments. Shifting from state courts and even circuit courts to the Supreme Court's jurisprudence often entails diving into longer opinions and complex analyses that may involve theory and history. This is especially true with respect to the First Amendment in the *Sullivan* era, in which new case law and standards were being developed and would continue to unfold for about two decades. The area is highly political (which remains true today). Defamation's constitutional jurisprudence delivers sketches of judicial philosophy to a greater extent than introductory torts materials typically do, thus permitting law students to begin to identify particular kinds of arguments and align them with judicial and political philosophies of law. Can you identify two to three arguments that are expressly political or ideological? What sorts of evidence and rationales do you observe in the justices' legal reasoning?

Note 3. How strong was "truth" as a defense in Alabama? What do you make of that?

Note 4. How robust does Alabama's "of and concerning" requirement appear to be?

Note 5. How relevant do you think it was that the dispute occurred in the context of the Civil Rights Movement and Alabama's role in resisting those efforts (with persistently segregationist policies, for instance)? Do your normative views of the clash between defamation and the First Amendment change depending on the context. If so, how so?

Note 6. Burdens of Proof. *Sullivan* kicked off an era of constitutionalization of defamation law that resulted in several lasting changes. One of these is that the court heightened the level of proof to be applied when determining various issues from a preponderance of the evidence to a "clear and convincing" standard. This higher standard applies to the issues of falsity, actual malice (knowledge of falsity or reckless disregard for the truth) and the "of and concerning" requirement, in cases involving public officials. *New York Times*, 376 U.S. at 284-85, 288-289. Subsequent cases extended this change to plaintiffs who are public figures (or limited-purpose public figures), and the higher standard often also applies when the person is a private figure involved in a matter of public or general concern.

Note 7. Justice Black's concurrence faults the majority for not going far enough. What does he believe the First Amendment permits? What is he concerned about with respect to actual malice?

Note 8. What is Justice Black concerned about with respect to damages? Why does it seem especially pressing to him at the time of the ruling and on the facts of this case?

Note 9. Like Justice Black, Justice Goldberg calls for recognition of an "absolute, unconditional privilege to criticize official conduct despite the harm which may flow from excesses and abuses." However, Goldberg's emphasis and arguments are somewhat different. What arguments and concerns do you identify in his concurrence?

Note 10. The Difficulty of Deciding Defamation Disputes as a Matter of Law. Due to *Sullivan* and its progeny, the precise culpability standard in defamation varies a great deal, depending on both the speaker and the person about whom the statement is made. Like *IIED* (which uses "intentional

conduct *or* recklessness” for its culpability standard), defamation in the modern era *can* come with Sullivan’s special “actual malice” standard. Public officials (such as the government actor in *Sullivan*) receive less protection from accidentally false speech. You can think of this almost like a kind of immunity for the rest of us, that is, as a privilege for speakers who wish to criticize the government or its officials. A commitment to robust freedom of expression about the government justifies imposing heightened protection for speech about public officials, and the way the tort of defamation accomplishes this is by heightening the culpability standard the plaintiff must satisfy. In the wake of *Sullivan*, however, the same rationale has been extended from public officials to “public figures,” such as celebrities. Like government officials, public figures similarly face higher hurdles to recover in defamation cases. Similarly, private citizens involved in matters of public concern are treated as public figures with respect to speech related to the matter of public concern.

The kinds of precautions a speaker must take to avoid charges of negligence can vary greatly depending on the circumstances. Defamation tends to be difficult to dismiss during early stages of a dispute because of the factual evidence needed to determine what the speaker knew or should have known and to evaluate the conditions under which they spoke. Further, whether something is *capable of carrying defamatory meaning* can be a difficult factual inquiry; whether it *actually communicated defamatory meaning* to the communication’s recipients is yet another; and whether the recipients of the communications understood them to be *about this plaintiff* is still a third. You have likely seen by now that many product liability and general negligence cases are quite fact-intensive; almost all defamation cases are equally or even more so.

Think back to Module 3’s discussions of duty as a judicial gatekeeping doctrine versus proximate cause as a liability limiting principle determined by the jury as a matter of fact. What arguments might you make in favor of facilitating dismissal of defamation cases on early motions as a matter of law (in a manner similar deciding to duty) versus letting defamation disputes proceed to a full factual record (in a manner similar to deciding proximate cause)? What is the right balance between the various interests protected, descriptively and normatively? What is the appropriate legal mechanism for achieving that balance, do you think?

Gertz v. Robert Welch, Inc., Supreme Court of the United States (1974) (418 U.S. 323)

Mr. Justice POWELL delivered the opinion of the Court.

This Court has struggled for nearly a decade to define the proper accommodation between the law of defamation and the freedoms of speech and press protected by the First Amendment. With this decision we return to that effort. We granted certiorari to reconsider the extent of a publisher’s constitutional privilege against liability for defamation of a private citizen. 410 U.S. 925 (1973).

***323** [Summary of facts: A Chicago policeman named Nuccio was convicted of murder. The victim’s family retained petitioner, Elmer Gertz, a reputable attorney, to represent them in civil litigation against Nuccio. Respondent Robert Welch’s magazine, *American Opinion*, which was published by the ultra-conservative John Birch society, featured an article that about Nuccio’s murder trial. The magazine alleged that the trial was part of a Communist conspiracy to discredit the local police, it falsely stated

that petitioner Gertz had arranged Nuccio's 'frameup,' it implied that Gertz had a criminal record, and falsely identified his political beliefs.] [****]

***326** In his capacity as counsel for the Nelson [victim's] family in the civil litigation, Gertz attended the coroner's inquest into the boy's death and initiated actions for damages, but he neither discussed Officer Nuccio with the press nor played any part in the criminal proceeding. Notwithstanding Gertz's remote connection with the prosecution of Nuccio, Welch's magazine portrayed him as an architect of the 'frameup.' According to the article, the police file on petitioner took 'a big, Irish cop to lift,' The article stated that Gertz had been an official of the 'Marxist League for Industrial Democracy, originally known as the Intercollegiate Socialist Society, which has advocated the violent seizure of our government.' It labeled Gertz a 'Leninist' and a 'Communist-fronter.' It also stated that Gertz had been an officer of the National Lawyers Guild, described as a Communist organization that 'probably did more than any other outfit to plan the Communist attack on the Chicago police during the 1968 Democratic Convention.'

These statements contained serious inaccuracies. The implication that Gertz had a criminal record was false. Gertz had been a member and officer of the National Lawyers Guild some 15 years earlier, but there was no evidence that he or that organization had taken any part in planning the 1968 demonstrations in Chicago. There was also no basis for the charge that Gertz was a 'Leninist' or a 'Communist-fronter.' And he had never been a member of the 'Marxist League for Industrial Democracy' or the 'Intercollegiate Socialist Society.'

***327** The managing editor of *American Opinion* made no effort to verify or substantiate the charges against Gertz. Instead, he appended an editorial introduction stating that the author (a regular contributor to the magazine) had 'conducted extensive research into the Richard Nuccio Case.' And he included in the article a photograph of Gertz and wrote the caption that appeared under it: 'Elmer Gertz of Red Guild harasses Nuccio.' The editor denied any knowledge of the falsity of the statements concerning Gertz and stated that he had relied on the author's reputation and on his prior experience with the accuracy and authenticity of the author's contributions to *American Opinion*. Welch placed the issue of *American Opinion* containing the article on sale at newsstands throughout the country and distributed reprints of the article on the streets of Chicago.

[Gertz] filed a diversity action for libel in the United States District Court for the Northern District of Illinois. He claimed that the falsehoods published by [Welch] injured his reputation as a lawyer and a citizen. Before filing an answer, respondent moved to dismiss the complaint for failure to state a claim upon which relief could be granted, apparently on the ground that petitioner failed to allege special damages. But the court ruled that statements contained in the article constituted libel per se under Illinois law and that consequently Gertz need not plead special damages. 306 F. Supp. 310 (1969)

After answering the complaint, respondent filed a pretrial motion for summary judgment, claiming a constitutional privilege against liability for defamation. It asserted that petitioner was a public official or a public figure and that the article concerned an issue of public interest and concern. For these reasons, respondent argued, it was entitled to invoke the privilege enunciated in *New York Times Co. v. Sullivan*, 376 U.S. 254, 84 S. Ct. 710, 11 L.Ed.2d 686 (1964). Under this rule respondent would escape liability unless ***328** petitioner could prove publication of defamatory falsehood 'with 'actual malice'—that is, with knowledge that it was false or with reckless disregard of whether it was false or not.' *Id.*, at 279—280, 84 S. Ct., at 726. Respondent claimed that petitioner could not make such a

showing and submitted a supporting affidavit by the magazine's managing editor. The editor denied any knowledge of the falsity of the statements concerning petitioner and stated that he had relied on the author's reputation and on his prior experience with the accuracy and authenticity of the author's contributions to American Opinion.

The District Court denied respondent's motion for summary judgment in a memorandum opinion of September 16, 1970. The court did not dispute respondent's claim to the protection of the New York Times standard. Rather, it concluded that petitioner might overcome the constitutional privilege by making a factual showing sufficient to prove publication of defamatory falsehood in reckless disregard of the truth. During the course of the trial, however, it became clear that the trial court had not accepted all of respondent's asserted grounds for applying the New York Times rule to this case. It thought that respondent's claim to the protection of the constitutional privilege depended on the contention that petitioner was either a public official under the New York Times decision or a public figure under *Curtis Publishing Co. v. Butts*, 388 U.S. 130 (1967), apparently discounting the argument that a privilege would arise from the presence of a public issue.

After all the evidence had been presented but before submission of the case to the jury, the court ruled in effect that petitioner was neither a public official nor a public figure. It added that, if he were, the resulting application of the New York Times standard would require a directed verdict for respondent. Because some statements in the article constituted libel per se *329 under Illinois law, the court submitted the case to the jury under instructions that withdrew from its consideration all issues save the measure of damages. The jury awarded \$50,000 to petitioner.

Following the jury verdict and on further reflection, the District Court concluded that the New York Times standard should govern this case even though petitioner was not a public official or public figure. It accepted respondent's contention that that privilege protected discussion of any public issue without regard to the status of a person defamed therein. Accordingly, the court entered judgment for respondent notwithstanding the jury's verdict.²³⁷ [***]

Petitioner appealed to contest the applicability of the New York Times standard to this case. Although the Court of Appeals for the Seventh Circuit doubted the correctness of the District Court's determination that petitioner was not a public figure, it did not overturn that finding.³ It agreed with the District Court that respondent could assert the constitutional privilege because the article concerned a matter of public interest... [***] After reviewing the record, the Court of Appeals endorsed the District Court's conclusion that petitioner had failed to show by clear and *332 convincing evidence that respondent had acted with 'actual malice' as defined by New York Times. There was no evidence that the managing editor of American Opinion knew of the falsity of the accusations made in the article. In fact, he knew nothing about petitioner except what he learned from the article. The court correctly noted that mere proof of failure to investigate, without more, cannot establish reckless disregard for

²³⁷ [***] [P]etitioner knew or should have known [***] [the outcome of the trial might hinge on his ability to show by clear and convincing evidence that respondent acted with reckless disregard for the truth. And this question remained open throughout the trial. Although the court initially concluded that the applicability of the New York Times rule depended on petitioner's status as a public figure, the court did not decide that petitioner was not a public figure until all the evidence had been presented. Thus petitioner had every opportunity, indeed incentive, to prove 'reckless disregard' if he could, and he in fact attempted to do so. The record supports the observation by the Court of Appeals that petitioner 'did present evidence of malice (both the 'constitutional' and the 'ill will' type) to support his damage claim and no such evidence was excluded. ...'

the truth. Rather, the publisher must act with a “high degree of awareness of . . . probable falsity.” [cc] The evidence in this case did not reveal that respondent had cause for such an awareness. The Court of Appeals therefore affirmed, 471 F.2d 801 (1972). For the reasons stated below, we reverse.

The principal issue in this case is whether a newspaper or broadcaster that publishes defamatory falsehoods about an individual who is neither a public official nor a public figure may claim a constitutional privilege against liability for the injury inflicted by those statements. [***]

Under the First Amendment there is no such thing as a false idea. However pernicious an opinion may seem, we depend for its correction not on the conscience of judges and juries but ***340** on the competition of other ideas.²³⁸ But there is no constitutional value in false statements of fact. Neither the intentional lie nor the careless error materially advances society’s interest in ‘uninhibited, robust, and wide-open’ debate on public issues. *New York Times Co. v. Sullivan*, 376 U.S., at 270. They belong to that category of utterances which ‘are no essential part of any exposition of ideas, and are of such slight social value as a step to truth that any benefit that may be derived from them is clearly outweighed by the social interest in order and morality.’ *Chaplinsky v. New Hampshire*, 315 U.S. 568, 572 (1942).

Although the erroneous statement of fact is not worthy of constitutional protection, it is nevertheless inevitable in free debate. [***] And punishment of error runs the risk of inducing a cautious and restrictive exercise of the constitutionally guaranteed freedoms of speech and press. Our decisions recognize that a rule of strict liability that compels a publisher or broadcaster to guarantee the accuracy of his factual assertions may lead to intolerable self-censorship. Allowing the media to avoid liability only by proving the truth of all injurious statements does not accord adequate protection to First Amendment liberties. As the Court stated in *New York Times Co. v. Sullivan*, supra, 376 U.S., at 279: ‘Allowance of the defense of truth, ***341** with the burden of proving it on the defendant, does not mean that only false speech will be deterred.’ The First Amendment requires that we protect some falsehood in order to protect speech that matters.

The need to avoid self-censorship by the news media is, however, not the only societal value at issue. If it were, this Court would have embraced long ago the view that publishers and broadcasters enjoy an unconditional and indefeasible immunity from liability for defamation. [cc] Such a rule would, indeed, obviate the fear that the prospect of civil liability for injurious falsehood might dissuade a timorous press from the effective exercise of First Amendment freedoms. Yet absolute protection for the communications media requires a total sacrifice of the competing value served by the law of defamation. The legitimate state interest underlying the law of libel is the compensation of individuals for the harm inflicted on them by defamatory falsehood. We would not lightly require the State to abandon this purpose, for, as Mr. Justice Stewart has reminded us, the individual’s right to the protection of his own good name ‘reflects no more than our basic concept of the essential dignity and worth of every human being—a concept at the root of any decent system of ordered liberty.’ [***]

342** Some tension necessarily exists between the need for a vigorous and uninhibited press and the legitimate interest in redressing wrongful injury. [] The *New York Times* standard defines the level of constitutional protection appropriate to the context of defamation of a public person. Those who, by reason of the notoriety of their achievements or the vigor and success with which they seek the public’s

²³⁸ Applying settled Illinois law, the District Court in this case held that it is libel per se to label someone a Communist.

attention, are properly classed as public figures and those who hold governmental office may recover for injury to reputation only on clear and convincing proof that the defamatory falsehood was made with knowledge of its falsity or with reckless disregard for the truth. This standard administers an extremely powerful antidote to the inducement to media self-censorship of the common-law rule of strict liability for libel and slander. And it exacts a correspondingly high price from the victims of defamatory falsehood.

Plainly many deserving plaintiffs, including some intentionally subjected to injury, will be unable to surmount the barrier of the New York Times test. Despite this *343 substantial abridgment of the state law right to compensation for wrongful hurt to one's reputation, the Court has concluded that the protection of the New York Times privilege should be available to publishers and broadcasters of defamatory falsehood concerning public officials and public figures. *New York Times Co. v. Sullivan*, supra; *Curtis Publishing Co. v. Butts*, supra. We think that these decisions are correct, but we do not find their holdings justified solely by reference to the interest of the press and broadcast media in immunity from liability. Rather, we believe that the New York Times rule states an accommodation between this concern and the limited state interest present in the context of libel actions brought by public persons. For the reasons stated below, we conclude that the state interest in compensating injury to the reputation of private individuals requires that a different rule should obtain with respect to them.

Theoretically, of course, the balance between the needs of the press and the individual's claim to compensation for wrongful injury might be struck on a case-by-case basis. As Mr. Justice Harlan hypothesized, 'it might seem, purely as an abstract matter, that the most utilitarian approach would be to scrutinize carefully every jury verdict in every libel case, in order to ascertain whether the final judgment leaves fully protected whatever First Amendment values transcend the legitimate state interest in protecting the particular plaintiff who prevailed.' *Rosenbloom v. Metromedia, Inc.*, 403 U.S., at 63 (footnote omitted). But this approach would lead to unpredictable results and uncertain expectations, and it could render our duty to supervise the lower courts unmanageable. Because an ad hoc resolution of the competing interests at stake in each particular case is not feasible, we must lay down broad rules of general *344 application. Such rules necessarily treat alike various cases involving differences as well as similarities. Thus it is often true that not all of the considerations which justify adoption of a given rule will obtain in each particular case decided under its authority.

With that caveat we have no difficulty in distinguishing among defamation plaintiffs. The first remedy of any victim of defamation is self-help—using available opportunities to contradict the lie or correct the error and thereby to minimize its adverse impact on reputation. Public officials and public figures usually enjoy significantly greater access to the channels of effective communication and hence have a more realistic opportunity to counteract false statements than private individuals normally enjoy.²³⁹ Private individuals are therefore more vulnerable to injury, and the state interest in protecting them is correspondingly greater.

More important than the likelihood that private individuals will lack effective opportunities for rebuttal, there is a compelling normative consideration underlying the distinction between public and private defamation plaintiffs. An individual who decides to seek governmental office must accept certain

²³⁹ This appears to have been the law in Illinois at the time Gertz brought his libel suit.

necessary consequences of that involvement in public affairs. He runs the risk of closer public scrutiny than might otherwise be the case. [***]

Those classed as public figures stand in a similar position. Hypothetically, it may be possible for someone to become a public figure through no purposeful action of his own, but the instances of truly involuntary public figures must be exceedingly rare. For the most part those who attain this status have assumed roles of especial prominence in the affairs of society. Some occupy positions of such persuasive power and influence that they are deemed public figures for all purposes. More commonly, those classed as public figures have thrust themselves to the forefront of particular public controversies in order to influence the resolution of the issues involved. In either event, they invite attention and comment.

Even if the foregoing generalities do not obtain in every instance, the communications media are entitled to act on the assumption that public officials and public figures have voluntarily exposed themselves to increased risk of injury from defamatory falsehood concerning them. No such assumption is justified with respect to a private individual. He has not accepted public office or assumed an ‘influential role in ordering society.’ [c] He has relinquished no part of his interest in the protection of his own good name, and consequently he has a more compelling call on the courts for redress of injury inflicted by defamatory falsehood. Thus, private individuals are not only more vulnerable to injury than public officials and public figures; they are also more deserving of recovery.

For these reasons we conclude that the States should retain substantial latitude in their efforts to enforce a ***346** legal remedy for defamatory falsehood injurious to the reputation of a private individual. [***] the Constitution [does not] require us to draw so thin a line between the drastic alternatives of the New York Times privilege and the common law of strict liability for defamatory error. The ‘public or general interest’ test for determining the applicability of the New York Times standard to private defamation actions inadequately serves both of the competing values at stake. On the one hand, a private individual whose reputation is injured by defamatory falsehood that does concern an issue of public or general interest has no recourse unless he can meet the rigorous requirements of New York Times. This is true despite the factors that distinguish the state interest in compensating private individuals from the analogous interest involved in the context of public persons. On the other hand, a publisher or broadcaster of a defamatory error which a court deems unrelated to an issue of public or general interest may be held liable in damages even if it took every reasonable precaution to ensure the accuracy of its assertions. And liability may far exceed compensation for any actual injury to the plaintiff, for the jury may be permitted to presume damages without proof of loss and even to award punitive damages.

347** We hold that, so long as they do not impose liability without fault, the States may define for themselves the appropriate standard of liability for a publisher or broadcaster of defamatory falsehood injurious to a private individual.²⁴⁰ [] This approach provides a more equitable ***348** boundary

²⁴⁰ Our caveat against strict liability is the prime target of Mr. Justice WHITE’S dissent. He would hold that a publisher or broadcaster may be required to prove the truth of a defamatory statement concerning a private individual and, failing such proof, that the publisher or broadcaster may be held liable for defamation even though he took every conceivable precaution to ensure the accuracy of the offending statement prior to its dissemination. Post, at 3031— 3033. In Mr. Justice WHITE’S view, one who publishes a statement that later turns out to be inaccurate can never be ‘without fault’ in any meaningful sense, for ‘(i)t is he who circulated a falsehood that he was not required to publish.’ Post, at 3033. [***] Mr. Justice WHITE asserts that our decision today ‘trivializes and denigrates the interest in reputation,’ [c], that

between the competing concerns involved here. It recognizes the strength of the legitimate state interest in compensating private individuals for wrongful injury to reputation, yet shields the press and broadcast media from the rigors of strict liability for defamation. [***]

Our accommodation of the competing values at stake in defamation suits by private individuals allows the States to impose liability on the publisher or broadcaster of defamatory falsehood on a less demanding showing than that required by *New York Times*. This conclusion is not based on a belief that the considerations which prompted the adoption of the *New York Times* privilege for defamation of public officials and its extension to public figures are wholly inapplicable to the context of private individuals. Rather, we endorse this approach in recognition of the strong and legitimate state interest in compensating private individuals for injury to reputation. *349 But this countervailing state interest extends no further than compensation for actual injury. For the reasons stated below, we hold that the States may not permit recovery of presumed or punitive damages, at least when liability is not based on a showing of knowledge of falsity or reckless disregard for the truth.

The common law of defamation is an oddity of tort law, for it allows recovery of purportedly compensatory damages without evidence of actual loss. Under the traditional rules pertaining to actions for libel, the existence of injury is presumed from the fact of publication. Juries may award substantial sums as compensation for supposed damage to reputation without any proof that such harm actually occurred. The largely uncontrolled discretion of juries to award damages where there is no loss unnecessarily compounds the potential of any system of liability for defamatory falsehood to inhibit the vigorous exercise of First Amendment freedoms. Additionally, the doctrine of presumed damages invites juries to punish unpopular opinion rather than to compensate individuals for injury sustained by the publication of a false fact. More to the point, the States have no substantial interest in securing for plaintiffs such as this petitioner gratuitous awards of money damages far in excess of any actual injury.

We would not, of course, invalidate state law simply because we doubt its wisdom, but here we are attempting to reconcile state law with a competing interest grounded in the constitutional command of the First Amendment. It is therefore appropriate to require that state remedies for defamatory falsehood reach no farther than is necessary to protect the legitimate interest involved. It is necessary to restrict defamation plaintiffs who do not prove knowledge of falsity or reckless disregard for the truth to compensation for actual injury. We *350 need not define ‘actual injury,’ as trial courts have wide experience in framing appropriate jury instructions in tort actions. Suffice it to say that actual injury is not limited to out-of-pocket loss. Indeed, the more customary types of actual harm inflicted by defamatory falsehood include impairment of reputation and standing in the community, personal humiliation, and mental anguish and suffering. Of course, juries must be limited by appropriate instructions, and all awards must be supported by competent evidence concerning the injury, although there need be no evidence which assigns an actual dollar value to the injury.

We also find no justification for allowing awards of punitive damages against publishers and broadcasters held liable under state-defined standards of liability for defamation. In most jurisdictions

it ‘scuttle(s) the libel laws of the States in . . . wholesale fashion’ and renders ordinary citizens ‘powerless to protect themselves.’ *Post*, at 3022. In light of the progressive extension of the knowing-or-reckless-falsity requirement [in this Court’s cases], one might have viewed today’s decision allowing recovery under any standard save strict liability as a more generous accommodation of the state interest in comprehensive reputational injury to private individuals than the law presently affords.

jury discretion over the amounts awarded is limited only by the gentle rule that they not be excessive. Consequently, juries assess punitive damages in wholly unpredictable amounts bearing no necessary relation to the actual harm caused. And they remain free to use their discretion selectively to punish expressions of unpopular views. Like the doctrine of presumed damages, jury discretion to award punitive damages unnecessarily exacerbates the danger of media self-censorship, but, unlike the former rule, punitive damages are wholly irrelevant to the state interest that justifies a negligence standard for private defamation actions. They are not compensation for injury. Instead, they are private fines levied by civil juries to punish reprehensible conduct and to deter its future occurrence. In short, the private defamation plaintiff who establishes liability under a less demanding standard than that stated by New York Times may recover only such damages as are sufficient to compensate him for actual injury.

Notwithstanding our refusal to extend the New York Times privilege to defamation of private individuals, respondent contends that we should affirm the judgment below on the ground that petitioner is either a public official or a public figure. There is little basis for the former assertion. Several years prior to the present incident, petitioner had served briefly on housing committees appointed by the mayor of Chicago, but at the time of publication he had never held any remunerative governmental position. Respondent admits this but argues that petitioner's appearance at the coroner's inquest rendered him a 'de facto public official.' Our cases recognized no such concept. Respondent's suggestion would sweep all lawyers under the New York Times rule as officers of the court and distort the plain meaning of the 'public official' category beyond all recognition. We decline to follow it.

Respondent's characterization of petitioner as a public figure raises a different question. That designation may rest on either of two alternative bases. In some instances an individual may achieve such pervasive fame or notoriety that he becomes a public figure for all purposes and in all contexts. More commonly, an individual voluntarily injects himself or is drawn into a particular public controversy and thereby becomes a public figure for a limited range of issues. In either case such persons assume special prominence in the resolution of public questions. [***]

Petitioner has long been active in community and professional affairs. He has served as an officer of local civic groups and of various professional organizations, and he has published several books and articles on legal subjects. Although petitioner was consequently well known in some circles, he had achieved no general fame ***352** or notoriety in the community. None of the prospective jurors called at the trial had ever heard of petitioner prior to this litigation, and respondent offered no proof that this response was atypical of the local population. We would not lightly assume that a citizen's participation in community and professional affairs rendered him a public figure for all purposes. Absent clear evidence of general fame or notoriety in the community, and pervasive involvement in the affairs of society, an individual should not be deemed a public personality for all aspects of his life. It is preferable to reduce the public-figure question to a more meaningful context by looking to the nature and extent of an individual's participation in the particular controversy giving rise to the defamation.

In this context it is plain that petitioner was not a public figure. He played a minimal role at the coroner's inquest, and his participation related solely to his representation of a private client. He took no part in the criminal prosecution of Officer Nuccio. Moreover, he never discussed either the criminal or civil litigation with the press and was never quoted as having done so. He plainly did not thrust himself into the vortex of this public issue, nor did he engage the public's attention in an attempt to influence its outcome. We are persuaded that the trial court did not err in refusing to characterize petitioner as a public figure for the purpose of this litigation.

We therefore conclude that the New York Times standard is inapplicable to this case and that the trial court erred in entering judgment for respondent. Because the jury was allowed to impose liability without fault and was permitted to presume damages without proof of injury, a new trial is necessary. We reverse and remand for further proceedings in accord with this opinion.

It is ordered. Reversed and remanded. *353

Mr. Chief Justice BURGER, dissenting.

The doctrines of the law of defamation have had a gradual evolution primarily in the state courts. In *New York Times Co. v. Sullivan*, 376 U.S. 254 (1964), and its progeny this Court entered this field.

Agreement or disagreement with the law as it has evolved to this time does not alter the fact that it has been orderly development with a consistent basic rationale. In today's opinion the Court abandons the traditional *355 thread so far as the ordinary private citizen is concerned and introduces the concept that the media will be liable for negligence in publishing defamatory statements with respect to such persons. Although I agree with much of what Mr. Justice WHITE states, I do not read the Court's new doctrinal approach in quite the way he does. I am frank to say I do not know the parameters of a 'negligence' doctrine as applied to the news media. Conceivably this new doctrine could inhibit some editors, as the dissents of Mr. Justice DOUGLAS and Mr. Justice BRENNAN suggest. But I would prefer to allow this area of law to continue to evolve as it has up to now with respect to private citizens rather than embark on a new doctrinal theory which has no jurisprudential ancestry.

The petitioner here was performing a professional representative role as an advocate in the highest tradition of the law, and under that tradition the advocate is not to be invidiously identified with his client. The important public policy which underlies this tradition—the right to counsel—would be gravely jeopardized if every lawyer who takes an 'unpopular' case, civil or criminal, would automatically become fair game for irresponsible reporters and editors who might, for example, describe the lawyer as a 'mob mouthpiece' for representing a client with a serious prior criminal record, or as an 'ambulance chaser' for representing a claimant in a personal injury action.

I would reverse the judgment of the Court of Appeals and remand for reinstatement of the verdict of the jury and the entry of an appropriate judgment on that verdict.

Note 1. Articulate for yourself the separate standards now applicable for plaintiffs who are a) public officials, b) public figures and c) private individuals bound up with a matter of public concern. Note the corresponding rules regarding damages. Observe where the burdens fall more heavily in each of the cases (plaintiffs or defendants)? The higher the standard for defamation plaintiffs, the greater the protection for speech and the lower the corresponding protection for reputational interests. Where do you fall, intuitively, and normatively, in your views of these interests and how to protect them?

Note 2. Normative assessments of *Gertz*. The dissenting opinions took aim at negligence law, especially a very long and scathing dissent authored by Justice Brennan, who was concerned that "unpopular opinions" could be censored under cover of non-meritorious defamation claims. He wrote:

[T]he flexibility which inheres in the reasonable-care standard will create the danger that a jury will convert it into "an instrument for the suppression of those 'vehement, caustic, and sometimes unpleasantly sharp attacks,' ... which must be protected if the guarantees of the First and Fourteenth Amendments are to prevail." [c] The Court does

not discount altogether the danger that jurors will punish for the expression of unpopular opinions. This probability accounts for the Court's limitation that "the States may not permit recovery of presumed or punitive damages, at least when liability is not based on a showing of knowledge of falsity or reckless disregard for the truth." [c] But plainly a jury's latitude to impose liability for want of due care poses a far greater threat of suppressing unpopular views than does a possible recovery of presumed or punitive damages. Moreover, the Court's broad-ranging examples of "actual injury," including impairment of reputation and standing in the community, as well as personal humiliation, and mental anguish and suffering, inevitably allow a jury bent on punishing expression of unpopular views a formidable weapon for doing so. Finally, even a limitation of recovery to "actual injury"—however much it reduces the size or frequency of recoveries—will not provide the necessary elbowroom for First Amendment expression. "It is not simply the possibility of a judgment for damages that results in self-censorship. The very *368 possibility of having to engage in litigation, an expensive and protracted process, is threat enough to cause discussion and debate to 'steer far wider of the unlawful zone' thereby keeping protected discussion from public cognizance. ... Too, a small newspaper suffers equally from a substantial damage award, whether the label of the award be 'actual' or 'punitive.'" [c]

Knowing what you now know about negligence law—on the one hand, its variability, fact-intensive, costly adjudication, and vulnerability to the jury, but on the other hand, its capacity for particularized rulings through by case-by-case tailoring, its capacity for change over time, and its reliance on the jury as an arbiter of the people—do you think negligence, strict liability, or some form of intentional tort is the best standard for private defamation cases?

Note 3. What do you think of how the court creates a combined standard using culpability *and* damages as levers? What are the costs and benefits of a hybrid approach like this one?

Note 4. "Negligence Plus." After *Sullivan*, it was clear that strict liability could no longer be used as the standard for culpability in defamation cases, no matter who the plaintiff. But it was unclear precisely *which* plaintiffs would need to prove actual malice, in addition to public officials. A pair of cases before the Supreme Court extended the actual malice standard to public figures. Accordingly, the litigation battleground shifted to some extent to focus on the question of whether the plaintiff was or wasn't a public figure. *Gertz* further clarified that for private figures involved in a matter of public concern, actual malice needed to apply. But it also ruled that presumed damages could no longer be permitted without a showing of actual malice. Effectively, this meant that the very lowest standard a state could require of a private plaintiff was proving negligence and special damages (regardless of the type of defamation alleged). In the alternative, a state could permit plaintiffs to presume damages in cases of defamation per se but only when also asserting actual malice (regardless of the status of the plaintiff). One way to capture this minimum standard following *Sullivan* is to frame it as "negligence plus." At a minimum, plaintiffs must prove negligence. They may also need to prove special damages, depending on the kind of defamation they are alleging and the culpability they can prove.

Contemporary Defamation's Elements

In consequence of wake of *Sullivan* and *Gertz*, the Restatement's section on defamation reflects the addition of a new element: **fault amounting to at least negligence** on the part of the publisher. Notice also that the first element now suggests that the plaintiff in *any* defamation case needs to prove not just that a statement was defamatory but also **that it was false**. There remains a significant amount of variety among the states in how they articulate the pleading and substantive requirements of the tort. Some states do not list minimum fault as a requirement but it will be required regardless, at least in cases involving public officials, public figures, and private citizens with respect to matters of public concern, given the Supreme Court's rulings. While not all states have adopted all parts of the Restatement § 558, some have done so and many states have adopted several aspects of it, so it provides a helpful point of reference.

Restatement Second of Torts § 558

§ 558. Elements Stated. To create liability for defamation there must be: (a) a false and defamatory statement concerning another; (b) an unprivileged publication to a third party; (c) **fault amounting to at least negligence on the part of the publisher** [with respect to the act of publication]; and (d) either actionability of the statement irrespective of special harm or the existence of special harm caused by the publication [emphasis added].

The next case provides a post-*Gertz* update that will cover long strides in defamation jurisprudence since *Sullivan*, contextualize the *Gertz* ruling, and illustrate how subsequent courts conduct the public/private figure analysis.

Defamation after *Gertz*

Lluberes v. Uncommon Productions, LLC, First Circuit (2011) (663 F.3d 6)

This case raises issues of First Amendment law. At the center of the dispute is *The Price of Sugar*, a documentary film released in 2007 by film company Uncommon Productions, LLC, and its principal William M. Haney, III. The film depicts the treatment of Haitian laborers on sugarcane plantations in the Dominican Republic. It refers by name to brothers Felipe and Juan Vicini Lluberes, senior executives of a family conglomerate that owns and operates Dominican sugar plantations. The Vicinis contend that the film is defamatory and sued the filmmakers in federal court. The filmmakers moved for summary judgment, which the court granted. The Vicinis appeal the entry of summary judgment and the denial of a motion to compel production of discovery materials. For the reasons that follow, we affirm in part the entry of summary judgment but otherwise vacate the judgment, vacate the order denying the motion to compel, and *11 remand for further proceedings consistent with this opinion.

The controversy that spawned *The Price of Sugar* is well catalogued in the district court's rescript, *Lluberes v. Uncommon Prod'ns, LLC*, 740 F.Supp.2d 207 (D.Mass.2010), and we will not

rehash it. Suffice it to say that the treatment of Haitian laborers on Dominican sugarcane plantations and the conditions of company towns (or *bateyes*) where they live have received scrutiny from many sectors for many years.

In 2004, the filmmakers began shooting in the Dominican Republic. Much of the film follows Fr. Christopher Hartley, a Roman Catholic priest critical of the Vicinis, as he seeks to improve conditions for his parishioners in the *bateyes*. Those conditions, the film highlights, include shanty quarters, inadequate provisions, and little if any education for children. At several points, Fr. Hartley and the film's narration reference Vicini-owned *bateyes* and identify Felipe and Juan as bearing some measure of responsibility for their disrepair. The film was released publicly on March 11, 2007, at a film festival in Texas. It has since received limited screenings in a handful of major cities and other venues.

Later in 2007, the Vicinis sued the filmmakers in federal district court in Massachusetts [where Haney resides] [fn]. Invoking the court's diversity jurisdiction, the Vicinis alleged that the film was defamatory and identified fifty-three statements, although they later winnowed the number of allegedly defamatory statements down to seven. The filmmakers seasonably moved for summary judgment on these remaining statements; they argued that Felipe and Juan were "public figures" required to prove "actual malice" in accordance with *New York Times Co. v. Sullivan*, 376 U.S. 254 (1964), and its progeny, and that the Vicinis could not so prove. The district court agreed and granted summary judgment in the filmmakers' favor.

At the same time, the court denied a motion to compel that the Vicinis had initially filed during discovery and later renewed. The motion sought production of several categories of documents; those at issue here include communications with a third-party "script annotator" that the filmmakers had withheld on attorney-client privilege grounds. The judge did not explain his reasoning. This appeal followed.

We begin with the public-figure question, then turn to the discovery dispute and go no further.

A. Public-Figure Status

1. Defamation and the First Amendment

Before the Supreme Court's decision in *New York Times*, defamation law was shaped by the states and strongly favored their interest in protecting an individual's reputation. *See Bruno & Stillman, Inc. v. Globe Newspaper Co.*, 633 F.2d 583, 586 (1st Cir.1980) ("Once a plaintiff put into evidence a reputation-harming statement and proof that defendant caused it to be disseminated, he enjoyed an irrebuttable presumption of injury and a rebuttable presumption of falsity.") [c] *12 That balance shifted in 1964, when the Court considered whether "the constitutional protections for speech and press limit a State's power to award damages in a libel action brought by a public official against critics of his official conduct." *N.Y. Times*, 376 U.S. at 256. Recognizing the "profound national commitment to the principle that debate on public issues should be uninhibited, robust, and wide-open," the Court reasoned that even falsehoods "must be protected if the freedoms of expression are to have the breathing space that they need to survive," [c]. On that basis, the Court held that the First Amendment "prohibits a public official from recovering damages for a defamatory falsehood relating to his official conduct unless he proves that the statement was made with 'actual malice'—that is, with knowledge that it was false or with reckless disregard of whether it was false or not."

The Court soon applied the *New York Times* rule to nonofficial “public figures.” *Curtis Publ’g Co. v. Butts*, 388 U.S. 130, 154–55 (1967). Under *Curtis*, a defamation plaintiff was to be considered a public figure when he “commanded sufficient continuing public interest and had sufficient access to the means of counter-argument to be able to expose through discussion the falsehood and fallacies of the defamatory statements.” *Id.* at 155 (internal quotation marks and citation omitted).

For a time, the *New York Times* rule was also extended to private individuals. *Rosenbloom v. Metromedia, Inc.*, 403 U.S. 29 (1971) (plurality opinion). According to the *Rosenbloom* plurality: “If a matter is a subject of public or general interest, it cannot suddenly become less so merely because a private individual is involved, or because in some sense the individual did not ‘voluntarily’ choose to become involved. The public’s primary interest is in the event[.]” *Id.* at 43, 91 S.Ct. 1811. Rather, the linchpin became simply “whether the utterance involved concerns an issue of public or general concern.” *Id.* at 44; *see also id.* at 43–44 (“We honor the commitment to robust debate on public issues, which is embodied in the First Amendment, by extending constitutional protection to all discussion and communication involving matters of public or general concern, without regard to whether the persons involved are famous or anonymous.”)

The plurality’s approach in *Rosenbloom*, however, was repudiated in *Gertz v. Robert Welch, Inc.*, 418 U.S. 323 (1974), which established the current framework. *Gertz* sought an accommodation between the “need to avoid self-censorship by the news media,” *id.* at 341, on the one hand, and the “legitimate state interest underlying the law of libel,” *id.*, on the other. It did so by linking “the constitutionally required showing in a defamation action to the plaintiff’s status.” *Pendleton v. City of Haverhill*, 156 F.3d 57, 67 (1st Cir.1998). Under this new model, public figures could succeed only on proof of actual malice as defined by *New York Times*. *Gertz*, 418 U.S. at 342. As for purely *13 private individuals, however, the states could “define for themselves the appropriate standard of liability” so long as minimal constitutional safeguards were met. *Id.* at 346–47. [***]

Gertz contemplated that public-figure status usually would arise in one of two ways, each with different repercussions. In one, “an individual may achieve such pervasive fame or notoriety that he becomes a public figure for all purposes and in all contexts”—the so-called general-purpose public figure. *Id.* at 351. But far more commonly (and directly relevant in this case) “an individual voluntarily injects himself or is drawn into a particular public controversy and thereby becomes a public figure for a limited range of issues”—the so-called limited-purpose public figure. *Id.* That “limited range of issues” is identified “by looking to the nature and extent of an individual’s participation in the particular controversy giving rise to the defamation.” *Gertz*, 418 U.S. at 352.²⁴¹

Guidance since *Gertz* has cautioned that a controversy must be more than a “cause célèbre,” *Time, Inc. v. Firestone*, 424 U.S. 448, 454 (1976), or “a matter that attracts public attention,” *Wolston v. Reader’s Digest Ass’n*, 443 U.S. 157, 167 (1979). Rather, it must be shown that “ ‘persons actually were discussing some specific question ... [and] a reasonable person would have expected persons beyond the immediate participants in the dispute to feel the impact of its resolution.’ ” *Bruno & Stillman*, 633 F.2d at 591 ([c]). Also, to avoid improper “bootstrapping” (a concept explored further

²⁴¹ There is possibly a third category, hinted at in *Gertz*, but it is not implicated in this case. *Pendleton*, 156 F.3d at 67 n. 7 (“The *Gertz* Court mentioned a third category—a person who becomes a public figure ‘through no purposeful action of his own’—but commented that ‘the instances of truly involuntary public figures must be exceedingly rare.’ ” (quoting *Gertz*, 418 U.S. at 345)).

below), the controversy must predate the alleged defamation [cc] (“[T]hose charged with defamation cannot, by their own conduct, create their own defense by making the claimant a public figure.”).

Once a controversy is isolated, the critical question then becomes whether the plaintiff has attempted to “influence the resolution” of that controversy. *See, e.g., [***] Pendleton*, 156 F.3d at 69 (holding that the defamation plaintiff was a public figure because he “voluntarily injected himself” into the controversy); *Bruno & Stillman*, 633 F.2d at 591 (requiring a “thrusting into the vortex”). If so, the plaintiff is a public figure and bears the heavy, and often insurmountable, burden of proving actual malice.

2. Felipe and Juan

The filmmakers contend that Felipe and Juan are limited-purpose public figures. The Vicinis vehemently dispute that label. Although they no longer contest the existence of a public controversy, the Vicinis argue that neither of them attempted to influence its resolution. Their argument has three constituent parts and spans both time and space. First, they say they did nothing *before 2003* that, standing alone, could subject them to public-figure status. Second, any conduct *after 2003* that might do so, we are told, is shielded by the anti-bootstrapping principle. The third is that, whatever their conduct in the Dominican Republic, it cannot make them public figures *in the United States*.

The status question is a legal one that we review *de novo*. [cc] We do so mindful that the inquiry is “inescapably fact-specific,” *Mandel v. Bos. Phoenix, Inc.*, 456 F.3d 198, 204 (1st Cir.2006), and does not always lend itself to summary judgment [***] But here, as in *Pendleton*, the Vicinis do not argue that the district court based its status determination on disputed facts, only that the undisputed facts were insufficient to make them public figures for the reasons outlined above. [fn 5] We disagree *15 and conclude, as did the district court, that both Felipe and Juan are limited-purpose public figures. Because we ultimately reject their anti-bootstrapping argument [fn], we find it appropriate to begin by examining all relevant conduct up to the film’s release in March 2007.

Within that span, both Felipe and Juan came to occupy leadership positions within the family businesses. Felipe began working for the company in the mid-to-late 1990s as a member of the board. He gradually became part of a small group of family members that directed the agricultural enterprise; among other things, he oversaw sugar exports and sought to ensure favorable trade policies with the United States (the largest importer of Dominican sugar) and other countries. Later he was installed as president of Grupo Vicini, the entity that manages the family’s investments and coordinates initiatives on the *bateyes*. Juan joined the company in 2000 directly out of school in the United States. He, too, began working on the agricultural side of the business and ultimately assumed the number-two position in Grupo Vicini, under Felipe. [fn]

Juan’s role was perhaps less conspicuous, but it focused on the *bateyes* from the beginning. His homecoming in 2000 coincided with Fr. Hartley’s controversial benediction—delivered during a visit to Fr. Hartley’s parish by the Dominican president—that was critical of the *batey* system and of those, including the Vicini family, responsible for it. The strongly worded benediction caught the attention of the media, prompting the Vicinis to call a meeting with Fr. Hartley. As a result of that meeting, which both Juan and Felipe attended, Juan took on the role of humanitarian attaché to Fr. Hartley and his cause of improving conditions on the *bateyes*. Over the next couple of years Juan and Fr. Hartley met about a dozen more times, toured the *bateyes* together, and regularly spoke by telephone. [***] *16 For reasons that are not altogether clear, the Vicini–Hartley collaboration fizzled in 2003 or

2004. But rather than abandon the project, the Vicinis embraced it as their own. For instance, Juan reached out to nongovernmental organizations in order to combat HIV/AIDS in the *bateyes*. [***] And around the same time, both Juan and Felipe began courting the U.S. embassy in Santo Domingo. Juan personally escorted embassy officials on visits to the *bateyes* [***]. For his part, Felipe spoke with embassy officials by telephone, including the U.S. ambassador. This outreach touched off a relationship between the Vicinis and U.S. diplomats that Felipe described as “ongoing.”

Their efforts entered a new phase in 2005. After a U.S. newspaper published an exposé critical of the *batey* system, the Vicinis brought in Newlink Communications, a public-relations (PR) firm based in the United States. Newlink’s proposal, signed by Felipe in April 2005, provided for a massive PR campaign in the Dominican Republic that would reach as far as the United States. Among other things, the proposal identified the need for a “strategic communications program” to deal with the “negative perceptions against the company, reaching the United States media,” “[b]lock messages” critical of the Vicinis, and “[i]mprove the image and reputation of the company in the eyes of the public.” It spelled out country-specific strategies, focusing on the Dominican Republic and the United States, designed to implement those general goals. And it included media training for both Felipe and Juan, in Spanish and English, such as mock interviews about the *bateyes* and model answers emphasizing Vicini initiatives. All told, the Newlink deal cost the Vicinis about \$1.2 million. [***]

The PR campaign also targeted international media outlets and policymakers, particularly in the United States. [***] Felipe sent a deputy to a PBS interview with the stated goal of attempting “to ‘flip’ the story” in the family’s favor. According to Newlink records, the deputy “was prepared ahead of time for that interview with a Q & A that Newlink drew up to ensure that his answers were in keeping with the goal of maintaining the [company’s] image intact.” And in late 2006, Felipe, accompanied by several Newlink team members, led a U.S. congressional delegation on a tour of Vicini *bateyes*. During the tour a “fact sheet” was distributed that described Vicini initiatives in detail. CNN covered the delegation and interviewed Felipe; clips of that interview aired on *Anderson Cooper 360°* and were rebroadcast multiple times over the next two months on CNN and its affiliates. Felipe testified that his goal during these events was “to try to get our story out, to get our side out.”

Shortly before the release of *The Price of Sugar* (the end of our continuum), Felipe and Juan hosted an industry luncheon in the Dominican Republic. One purpose of the luncheon was to reveal more Vicini initiatives on the *bateyes*. During the luncheon, journalists from several Dominican newspapers were permitted to attend and ask questions. The resulting articles highlighted the *batey* initiatives discussed during the event and, as before, pictured and quoted Felipe and Juan.

All together, this conduct shows beyond hope of legitimate contradiction that Felipe and Juan are limited purpose public figures. Both leveraged their positions and contacts to influence a favorable outcome in the *batey* controversy. Both enjoyed access to the press and exploited it by orchestrating a PR blitz to garner public support and mute their critics. [fn] In doing so, both assumed roles of prominence for this limited purpose and the risk of closer public scrutiny that came with it.

3. Bootstrapping [***]

The Vicinis try to avoid this conclusion by asserting that most of the above conduct is shielded by the bootstrapping taboo. The argument is as follows. All of their “public activities” occurred after and in response to an article in a Spanish newspaper, *El Mundo*, published in January 2003. The article included purportedly defamatory statements by Fr. Hartley, the “original defamer,” that were repeated

in the film four years later. Because the Vicinis would not have entered the public arena but for the *El Mundo* article, the filmmakers cannot invoke the Vicinis' status as a defense to the same defamation in the film.

The argument is creative, but this case does not fit the bootstrapping mold. Bootstrapping in this context occurs when the defendant relies on his own defamatory publication to manufacture a public controversy involving the plaintiff, and thus “by [his] own conduct, create[s his] own defense by making the claimant a public figure.” *Hutchinson*, 443 U.S. at 135, 99 S.Ct. 2675. That is the logic behind the requirement that public-figure status—whether acquired for all purposes and in all contexts or derived from a particular controversy—predate the alleged defamation. [cc] see generally Smolla, *Law of Defamation* § 2:25 (recognizing “the media’s potential for ‘bootstrapping’ itself into the protection of the actual malice standard by pointing to its own coverage of the plaintiff as evidence that the plaintiff is a public figure,” and that in response “a number of courts have emphasized that the public controversy must ‘preexist’ the speech giving rise to the defamation suit”). [***]

4. Public Figures and Geography

The Vicinis' final argument on the limited-purpose public figure issue is a geographic one. They say that none of the above conduct makes them public figures in the United States, where the alleged defamation was published. The argument rests on an analogy to *general-purpose* public figures, and those authorities that require such individuals to have achieved notoriety where they were defamed. The Vicinis reason that this geographic restriction must also be true for *limited-purpose* public figures, who are the more “protected” of the two.

The analogy is flawed. *Gertz* held that the plaintiff was not a public figure for all purposes because he had “no general fame or notoriety in the community” and was not generally known to “the local population.” 418 U.S. at 351–52. Based on that language, some courts—we have not addressed the question and we do not do so today—have extrapolated that a general-purpose public figure need not attain “nationwide fame,” only “notoriety where he was defamed[,] *i.e.*, where the defamation was published.” [c] Arguably, this so-called community standard actually expands rather than restricts the applicability of the *New York Times* rule, at least for general-purpose public figures.

That debate, however, has no relevance here. *Gertz* defined a *limited-purpose* public figure not in terms of geography but in terms of the controversy that he has stepped into. See *Gertz*, 418 U.S. at 351 (defining a limited-purpose public figure as one who “voluntarily injects himself or is drawn into a particular controversy”); *21 *Tavoulaareas*, 817 F.2d at 772 (“[T]he scope of the controversy in which the plaintiff involves himself defines the scope of the public personality.”). That suggests to us that, if *Gertz* envisioned any limitation on public-figure status, it is a limitation inherent in the scope of the controversy itself. [***] [T]he *batey* controversy was not confined to the shores of the Dominican Republic. Rather, it resounded in the United States for obvious humanitarian reasons and a less-obvious geopolitical one: a long-standing import quota system under U.S. law that subsidizes Dominican sugar producers, including the Vicinis.²⁴² Indeed, one of Felipe’s core responsibilities was seeing to it that

²⁴² For a history of the subsidy, see for example Michael R. Hall, *Sugar and Power in the Dominican Republic: Eisenhower, Kennedy, and the Trujillos* (2000). For current efforts in Congress to undo the subsidy, see Stop Unfair Giveaways and Restrictions (SUGAR) Act, S. 25, 112th Cong. § 4 (as introduced and referred to S. Comm. on

this quota system remained intact through lobbying and other efforts. Concerns that negative publicity about the *bateyes* might jeopardize the quota system prompted him and Juan, at least in part, to launch the PR blitz that reached U.S. media outlets and policymakers, as we have shown. We are satisfied that such conduct is enough to make the plaintiffs public figures in the United States for purposes of this lawsuit. [fn]

*22 B. Attorney–Client Privilege

[Editor’s note: In a separate motion, the lower court had protected various documents under the attorney-client privilege. These documents had been at issue when the filmmakers had sought “errors and omissions” insurance which is an ordinary part of the process. Without these, the court here holds it impossible to reach the factual questions necessary to determine actual malice.]

By safeguarding communications between attorney and client, the privilege encourages disclosures that facilitate the client’s compliance with law and better enable him to present legitimate arguments when litigation arises. [c] The privilege is not limitless, however, and “courts must take care to apply it only to the extent necessary to achieve its underlying *24 goals.” [c] In other words, “the attorney-client privilege must be narrowly construed because it comes with substantial costs and stands as an obstacle of sorts to the search for truth.” [c] [***] The contours of the privilege are reasonably well honed. It protects “only those communications that are confidential and are made for the purpose of seeking or receiving legal advice.” [***]

The doctrine construing the attorney-client privilege narrowly seems to favor production in this instance. That doctrine strikes us as particularly applicable in defamation cases, such as this one, involving public figures. ... Actual malice must be proven with “convincing clarity,” *N.Y. Times*, 376 U.S. at 285–86, and this same standard applies whether the matter is resolved on summary judgment or at trial, *Anderson v. Liberty Lobby, Inc.*, 477 U.S. 242, 244 (1986). Mindful of this hefty burden, upholding the district court’s decision on this record to withhold the sought documents which seemingly bear directly on state of mind would be incompatible with the “search for truth.” *Nixon*, 418 U.S. at 710.

This conclusion prevents us from reaching the issue of actual malice. Whatever documents must be produced, the trial judge did not examine them when he granted summary judgment in favor of the filmmakers on that issue. And because the documents have not been submitted to us, we cannot determine whether summary judgment was warranted despite them. We are cognizant, nevertheless, that even should some documents or portions thereof be disclosed in the end, some of the district court’s rulings on the seven putative defamatory statements may still stand. And yet we deem it is unwise to embark on a piecemeal approach to these statements at this juncture. On remand, the actual malice issue will have to be readdressed should any documents be disclosed.

We recognize the possibility that some documents, or portions of some documents, may contain information that is privileged under the framework set forth above. Rather than risk disclosure of such information, the district court has the option within its discretion on remand to review these documents in camera, allow the filmmakers to withhold any documents covered by privilege, and redact prior to production any portions of admissible documents that it finds are privileged. The court also may need

Agriculture, Nutrition, and Forestry, Jan. 25, 2011), and *Sen Shaheen Wants to End the Sugar Subsidies* (NHPR radio broadcast Mar. 2, 2011), <http://www.nhpr.org/sen-shaheen-wants-end-sugar-subsidies>.

to consider on remand the Vicinis' waiver argument pertaining to the sufficiency of the privilege log, and choose to entertain other legitimate arguments relative to disclosure, waiver and privilege which the parties seek to raise.

27 []** For these reasons, we affirm the limited purpose public figure status determination but otherwise vacate the dispositive judgment, vacate the denial of the motion to compel insofar as the [attorney-client privileged] documents are concerned, and remand for further proceedings consistent with this opinion. We take no position on the actual-malice issue. The parties shall bear their own costs.

Note 1. The case was brought in Massachusetts because Haney was reachable there. Why else do you imagine it might have been brought there given that Uncommon Productions is actually based in California?

Note 2. If you were to assess these facts intuitively—that is, setting aside the considerable knowledge of torts and civil procedure that you have now amassed—how would you describe what the Vicini brothers were trying to do? What would you want to happen, *intuitively*? Now consider this question *descriptively*, as a function of the tort doctrines you know. Do you arrive at the same result? How about *normatively*? Is this the sort of situation Justice Brennan was worrying about, in the excerpt from his dissent (which was provided *supra* at Note 2 following *Gertz v. Welch*)?

Note 3. Are there particular contexts in which humanitarian issues—perhaps related to human rights or social justice concerns—might prompt special protections for speech or warrant deliberate prioritization of speech over reputational interests? Is this already the practical effect of the actual malice requirement? Can you think of other ways it might be possible to ensure that defamation lawsuits don't chill speech on issues of public concern with respect to humanitarian issues? If so, how would you define the threshold for "humanitarian issues" (or any related subset of issues you would wish to prioritize)?

Chapter 38. Defenses and Limitations

The First Amendment provides important limits by requiring that the plaintiff prove a higher level of culpability in cases involving public officials, public figures and private individuals involved with matters of public concern. In addition, there are a number of defenses to defamation claims, and they fall into two main categories: **absolute** and **qualified or conditional defenses**.

Absolute defenses. These include **consent, truth and absolute privileges that protect certain contexts**. Consent is straightforward in that it is similar to the analysis in battery; if the plaintiff consented to the communication, there can be no liability for its having occurred. As demonstrated in *Federal Credit v. Fuller* and *Sullivan v. N.Y. Times, supra*, truth is a significant defense to defamation claims. Indeed, truth can trump even outright malice. *See e.g.* Restatement (First) of Torts § 582 (1938) (“The truth of a defamatory statement of fact is a complete defense to an action for defamation.” *Comment a.* Except as otherwise provided by statute, the truth of a defamatory statement of fact is a complete defense although it is made for no good purpose and is inspired by ill will toward the person about whom it is published and is made solely for the purpose of harming him.”) Some jurisdictions have modified this common law rule by statute. However, the default rule illustrates the strength of truth as a defense. Finally, absolute privileges cover communications in particular contexts and permit a broad range of statements so long as they are relevant to or made within the proper scope of the given context. For example, there is an absolute privilege extended to judicial and legislative proceedings, and even knowingly making false statements during deliberation or debate on the floor of the legislature would be protected from liability for defamation even if subject to other forms of sanction or penalty. *Hutchinson v. Proxmire*, 443 U.S. 111 (1979)). There is also an absolute privilege shielding communications between spouses.

Qualified privileges protect certain occasions for which the law has recognized a need or justification for communications. Several exist but the most common is likely the “**common interest**” (or **mutual interest**) **privilege** that provides a limited entitlement to share information.

Restatement (First) of Torts § 596 (1938)

An occasion is conditionally privileged when the circumstances are such as to lead any one of several persons having a common interest in a particular subject matter correctly or reasonably to believe that facts exist which another sharing such common interest is entitled to know.

The privilege is frequently used in employment contexts for hiring and promotion and the general rule is that belonging to the same organization (such as a religious, charitable, social or professional organization) gives rise to a privilege for communications among members or colleagues to discuss the qualifications and character of their officers and members. Partners, shareholders, owners of common property and other joint venturers are also recognized as having a common privilege, for similar reasons.

If a defendant proves the existence of a qualified privilege, the plaintiff may defeat the privilege by showing the defendant abused the privilege or acted with common law malice. Restatement (Second)

of Torts, § 613(1)(h), p. 307.) Conditional privileges can also be defeated when parties exceed their scope, potentially by sharing *irrelevant* negative information or through excessive publication. Some states have also formalized qualified privileges for news reporting or other limited purposes.

Lastly, the **statute of limitations** in all states ranges from 1 to 3 years. The length may even vary by the type of defamation; in Arkansas, the limit is one year for slander (Ark. Code Ann. § 16-56-104) and three years for libel (Ark. Code Ann. § 16-56-105).

**Tuomela v. Waldorf-Astoria Grand Wailea Hotel, U.S. Dis. Ct. D. Hawai'i
(2021)
(2021 WL 233695)**

[***][Wendy] Tuomela's Complaint alleges that she was wrongfully terminated in April 2018 from her 20-year tenure of employment at the Grand Wailea Hotel. She claims she was falsely accused of theft, and was forced to pay the Hotel \$900 in cash, which apparently was part of the amount she was accused of stealing. The Complaint alleges that after being accused, she was threatened with incarceration by a security guard (Michael Palazzotto) and Defendant's human resources representative (Carol Kawabata) if she did not pay (or return) the money. It alleges that on April 17, 2018, Kawabata entered into a contract with Plaintiff to keep the circumstances of her termination confidential. Instead, the Complaint alleges that Kawabata told a hotel restaurant manager, Justin Sugarman, that Plaintiff was fired for theft and misconduct, and Sugarman told other staff members. Since that time, Plaintiff was denied comparable employment for similar positions from other employers and was "essentially blackballed from any employment in Wailea[.]" She alleges that a "false police report surfaced when she was applying for a job which required a background check [and] [d]ue to the defamatory nature of the police report she did not get the position she was seeking."

Plaintiff [***] alleges "defamation of character" based on two general theories. [fn] First, Tuomela contends that she was defamed when Kawabata told Sugarman "confidential information" that Tuomela was terminated for theft and misconduct, and then Sugarman told others. She alleges that her reputation was damaged as a result. Second, Count Three alleges:

On August 3rd, 2018, in a continuing search for comparable employment, Ms. Tuomela was confronted with a police report [***] that states ... she is accused of theft. The false police report surfaced when she was applying for a job which required a background check. Due to the defamatory nature of the police report she did not get the position she was seeking. ... She has not been able to gain employment equal to the position that she lost as a server at the Humu Room in the Grand Wailea Hotel. Waldorf's Motion is directed only at the defamation allegations regarding the police report. [fn] That is, Waldorf does not seek, at least with this Motion, a ruling regarding the allegations about statements Kawabata made to Sugarman that were relayed to others. Rather, this Motion only argues that statements made to police complaining of a crime are not actionable as defamation, contending that such statements are absolutely privileged.

A. An Absolute Privilege is the Minority Rule

Waldorf cites several cases holding that an absolute privilege protects statements made to police, and thus encourages persons to report criminal activity to authorities without fear of retaliation. The interest is “encouraging the free and unhindered communications to law enforcement authorities necessary to facilitate the investigation and prosecution of crimes.” *Ledvina v. Cerasini*, 213 Ariz. 569 (Ariz. Ct. App. 2006); see also, e.g., *Eddington v. Torrez*, 311 Mich. App. 198 (Mich. Ct. App. 2015) (“[P]ersons who make statements to the police when reporting crimes or assisting the police in investigating crimes enjoy a privilege in those statements against the police divulging them for any purpose other than law enforcement. Accordingly, those statements may not be used to sustain a defamation claim.”). In *Hagberg v. California Federal Bank FSB*, 32 Cal.4th 350 (Cal. 2004), for example, the California Supreme Court held that, under California Civil Code § 47(b),²⁴³ statements made to law enforcement personnel reporting suspected criminal activity are “absolutely” privileged “and can be the basis for tort liability only if the plaintiff can establish the elements of the tort of malicious prosecution.” [cc] “[T]he absolute privilege established by section 47(b) serves the important public policy of assuring free access to the courts and other official proceedings. It is intended to ‘assure utmost freedom of communication between citizens and public authorities whose responsibility is to investigate and remedy wrongdoing.’ ” *Id.* at 249, 81 P.3d at 245 ([c] (emphasis omitted)).²⁴⁴

***3** But Waldorf relies on a minority rule. Rather, as the Idaho Supreme Court recently reiterated, “the majority rule is that statements made to law enforcement enjoy [only] a qualified privilege from defamation actions, which can be lost through abuse, such as when statements are made with malice or in bad faith.” [c]. “[A] qualified privilege [strikes] the appropriate balance between protecting those who seek to report criminal conduct to law enforcement and the countervailing interest in remedying the ‘potentially disastrous consequences that may befall the victim of a false accusation of criminal wrongdoing.’ ” [c]

In analyzing case law from various jurisdictions, the Connecticut Supreme Court followed “a majority of states that have addressed this issue[.]” [c], and agreed with the Florida Supreme Court that “a qualified privilege is sufficiently protective of [those] wishing to report events concerning crime. [c] There is no benefit to society or the administration of justice in protecting those who make intentionally false and malicious defamatory statements to the police.” *Id.* (quoting *Fridovich v. Fridovich*, 598 So. 2d 65, 69 (Fla. 1992)). In turn, *Fridovich* broadly surveyed state case law and other authorities, 598 So. 2d at 67-68 & n.4, and followed “a majority of the other states [that] have held in this context, that defamatory statements voluntarily made by private individuals to the police ... prior to the institution of criminal charges are presumptively qualifiedly privileged.” *Id.* at 69. Many of these opinions distinguish between statements made as part of existing judicial or quasi-judicial proceedings (such as

²⁴³ Section 47(b) provides in part: “A privileged publication or broadcast is one made: ... (b) In any (1) legislative proceeding, (2) judicial proceeding, (3) in any other official proceeding authorized by law, or (4) in the initiation or course of any other proceeding authorized by law and reviewable pursuant to [statutes governing writs of mandate],” with certain statutory exceptions.

²⁴⁴ *Hagberg*, however, was largely superseded this year by the California Legislature. Effective January 1, 2021, the California Legislature amended § 47(b) by adding an exception to the absolute privilege that provides: (5) This subdivision does not make privileged any communication between a person and a law enforcement agency in which the person makes a false report that another person has committed, or is in the act of committing, a criminal act or is engaged in an activity requiring law enforcement intervention, knowing that the report is false, or with reckless disregard for the truth or falsity of the report. See 2020 Cal. Legis. Serv. Ch. 327 (A.B. 1775). Given this amendment, under current California law there is only a qualified privilege for reports of a crime—reports that are intentionally false or made with reckless disregard of their truth are not privileged.

trial testimony)—for which an absolute privilege from defamation exists—and statements to police before the initiation of proceedings—which are subject to a qualified privilege. [cc]

B. The Court Applies the Majority Rule—A Qualified Privilege

Under the *Erie* doctrine, the court applies substantive Hawaii law in the present case, which is based on diversity of citizenship. *See Erie R. Co. v. Tompkins*, 304 U.S. 64 (1938). Hawaii has not adopted either the majority or minority rule as to the degree of privilege from defamation given to statements made to police *before* criminal proceedings are initiated.²⁴⁵ Thus, absent certifying a question to the Hawaii Supreme Court, this “court, sitting in diversity, must use its best judgment to predict how the Hawaii Supreme Court would decide the issue.” [c] “In so doing, a federal court may be aided by looking to well-reasoned decisions from other jurisdictions.” [c] And—using its best judgment and analyzing those well-reasoned decisions—this court applies the majority rule here. That is, a qualified (not absolute) privilege applies under Hawaii law.

*4 The court begins with the proposition that, under Hawaii law, statements that “impute to a person the commission of a crime” are defamatory *per se*.²⁴⁶ [cc] As such, Hawaii courts would likely conclude that “the law should provide a remedy” against “those who make intentionally false and malicious defamatory statements to the police.” *Fridovich*, 598 So. 2d at 69. Although the law should encourage reporting of criminal activity, “public policy is [not] violated by requiring that citizens who report criminal activities to the police do so in good faith.” *Gallo*, 935 A.2d at 114 (quoting *Caldor, Inc. v. Bowden*, 330 Md. 632 (Md. Ct. App. 1993)). “Those who maliciously volunteer false accusations of criminal activity to the police should not be granted absolute immunity. Although [courts] do not wish

²⁴⁵ In existing litigation, “Hawaii courts have applied an absolute litigation privilege in defamation actions for words and writings *that are material and pertinent to judicial proceedings.*” *Matsuura v. E.I. du Pont de Nemours and Co.*, 102 Haw. 149, 154 (2003) (citations omitted) (emphasis added). In that regard, *Matsuura* reiterated the holding from *Ferry v. Carlsmith*, 23 Haw. 589 (1917) that it is “well settled that attorneys, in the conduct of judicial proceedings, are privileged from prosecution for libel or slander in respect to words or writings, used in the course of such proceedings, reflecting injuriously upon others, when such words and writings are material and pertinent to the question involved.” *Id.* at 591. *Ferry*, however, gave limits to that “absolute” privilege:

The communication is absolutely privileged if the same is a fair comment upon the evidence and relevant to the matters at issue. Counsel is not liable to answer for defamatory matter uttered by him in the trial of a cause if the matter is applicable and pertinent to the subject of inquiry, but this privilege of counsel must be understood to have this limitation, that he shall not avail himself of his situation to gratify private malice by uttering slanderous expressions against party, witness, or third persons which have no relation to the subject-matter of the inquiry. *Id.* (quotation marks and citation omitted).

²⁴⁶ Of course, the statement must also be false to be actionable as defamation. *See Gold*, 88 Haw. at 100, 962 P.2d at 359 (requiring “a false *and* defamatory statement concerning another” as an element of defamation) (emphasis added). As the Hawaii Supreme Court has explained:

A finding that the publication is libelous *per se* presumes damages to the injured party and thus special damages need not be shown. This is not, however, determinative of the issue whether defendant is liable. The claim for relief remains subject to a privilege defense asserted by the publisher of the defamatory material. *Russell v. Am. Guild of Variety Artists*, 53 Haw. 456, 459 (1972).

to discourage the reporting of criminal activity, [they] also do not wish to encourage harassment, or wasting of law enforcement resources, by investigations of false, maliciously made complaints[.]” *Id.* (quoting *Bowden*, 625 A.2d at 968).

Further, the Hawaii Supreme Court has not hesitated to eliminate absolute immunity in favor of a qualified privilege in tort situations against government officials. In *Medeiros v. Kondo*, 55 Haw. 499 (1974), for example, the Hawaii Supreme Court held that a nonjudicial government official has only a qualified privilege for acts done while exercising authority, and may be held liable where the official “is motivated by malice, and not by an otherwise proper purpose.” *Id.* at 503. In so doing, it overruled prior Hawaii law “[t]o the extent that absolute immunity from tort suit for nonjudicial officers may have been the law in Hawaii[.]” *Id.* at 500-01; *see also Runnels v. Okamoto*, 56 Haw. 1, 4 (1974) (explaining that “[i]n *Kondo*, we announced that the doctrine of ‘absolute immunity’ would no longer be permitted to shield a nonjudicial government officer for his tortious acts[.]” and applying *Kondo*’s qualified privilege standard to a defamation claim). The Hawaii Supreme Court later extended *Kondo* to acts of the Honolulu prosecuting attorney, again rejecting absolute immunity in favor of a qualified privilege. *See Orso v. City & Cnty. of Honolulu*, 56 Haw. 241, 247-48 (1975), *overruled on other grounds by Kahale v. City & Cnty. of Honolulu*, 104 Haw. 341 (2004). These cases rejected absolute immunity because the Hawaii Supreme Court was “unwilling to deny plaintiffs a ‘mere inquiry into malice’ [given its] strong preference for allowing all litigants their day in court.” *Kondo*, 55 Haw. at 504 (quoting 2 F. Harper & F. James, *The Law of Torts* § 29.10 at 1645 (1956)). [fn]

*5 With that indication embedded in Hawaii case law, and considering the weight of case law from other jurisdictions, the court concludes that under Hawaii law an absolute privilege does not apply to complaints made to police. The court declines to apply the minority rule suggested by Waldorf that communications in a police report are absolutely privileged.

Given this ruling, the court will apply existing Hawaii law, which holds more generally that, for claims of defamation, a speaker is protected by a qualified privilege when he or she “reasonably acts in the discharge of some public or private duty, legal, moral, or social, and where the publication concerns subject matter in which the author has an interest and the recipients of the publication a corresponding interest or duty.” *Russell*, 53 Haw. at 460, 497 P.2d at 44.

[T]he qualified privilege is conditional and it must be exercised (1) in a reasonable manner and (2) for a proper purpose. The immunity is forfeited if the defendant steps outside the scope of or abuses the privilege. The qualified privilege may be abused by (1) excessive publication, (2) use of the occasion for an improper purpose, or (3) lack of belief or grounds for belief in the truth of what is said.

Kainz v. Lussier, 4 Haw. App. 400, 405 (Haw. Ct. App. 1983) (citations omitted). And the party claiming defamation has the burden of proving that a qualified privilege was abused. *See Towse v. State*, 64 Haw. 624, 632 (1982).

For the foregoing reasons, Defendant Waldorf’s Motion for Judgment on the Pleadings as to Count Three, alleging defamation of character, is DENIED. Count Three remains in full.

Note 1. Why do you think the court declined to adopt Waldorf-Astoria’s argument in favor of an absolute privilege, descriptively and normatively? What are situations in which an absolute privilege makes sense, in your view?

Note 2. For a privilege that’s considered “conditional” and “qualified”, what do you observe about its scope as defined in *Russell*: “a speaker is protected by a qualified privilege when he or she reasonably acts in the discharge of some public or private duty, legal, moral, or social, and where the publication concerns subject matter in which the author has an interest and the recipients of the publication a corresponding interest or duty”? What duties are included or excluded? What perspective is used and what is the effect of that choice?

Note 3. The socioeconomic disparity between the parties—one of whom appears pro se (that is, represents themselves in court)—is striking. Does the court adopt appropriate modes of dealing with it? Is defamation properly calibrated here to balance speech and reputational interests? Why or why not?

Statutory Defenses

In addition to privileges available at common law, significant statutory defenses exist that bar or limit defamation claims.

The first of these is a federal statute. Congress enacted the Communications Decency Act (“CDA”)—whose Section 230 has been in the news a great deal recently—to immunize internet service providers from claims for defamation under certain conditions. The immunity was broad and robust and has been attacked again and again in court with very few lapses or suggestions that it can be undone. In most cases, challenges to Section 230’s immunity have failed. (If you know of counter-examples, they may have to do with child pornography or sex trafficking; those are sometimes considered “sui generis” categories that require their own treatment given how seriously offensive they are and Congress codified certain exceptions at Section (230 (e).)

The next case provides an example of CDA Sec. 230 litigation. It illustrates how even in a very factually compelling context in which there were existing policy prerogatives and legislative protections against racially discriminatory practices in fair housing, the immunity was upheld.

Chicago Lawyers’ Committee for Civil Rights, Inc. v. Craigslist, Inc. U.S. Dist. Ct. N.D. Ill. (2011) (461 F. Supp.2d 681)

Plaintiff Chicago Lawyers’ Committee for Civil Rights Under Law, Inc. (“CLC”) has filed suit under 42 U.S.C. § 3604(c) of the Fair Housing Act (“FHA”) seeking monetary, declaratory, and injunctive relief against Defendant “Craigslist, Inc.” (“Craigslist”). CLC alleges that such relief is warranted because Craigslist publishes notices, statements, or advertisements with respect to the sale or rental of dwellings that indicate (1) a preference, limitation, or discrimination on the basis of race, color, religion, sex, familial status, or national origin; and (2) an intention to make a preference, limitation,

or discrimination on the basis of race, color, religion, sex, familial status, or national origin. Craigslist has moved for judgment on the pleadings pursuant to Fed.R.Civ.P. 12(c) (“Rule 12(c)”), contending that Plaintiff’s claim is barred based on the immunity afforded to “providers ... of interactive computer services” (“ICSs”) under 47 U.S.C. § 230 (“Section 230”).

For the reasons below, the Court grants Craigslist’s motion.

I. The Parties

Plaintiff CLC, a public interest consortium of forty-five law firms, is an Illinois non-profit organization with its principal place of business in Chicago, Illinois. CLC’s mission is to promote and protect civil rights, particularly the civil rights of the poor, ethnic minorities, and the disadvantaged. CLC strives to eliminate discriminatory housing practices by: (1) educating people about their rights under the fair housing and fair lending laws; (2) investigating complaints of fair housing discrimination; (3) providing referral information for non-discrimination housing matters; (4) advocating on a wide range of housing related issues, such as public housing, increased affordable housing, and fair and equal mortgage lending opportunities; and (5) providing free legal services to individuals and groups who wish to exercise their fair housing rights and secure equal housing opportunities. (*Id.*)

Defendant Craigslist is a Delaware corporation located in San Francisco, California that operates a website through “a small staff in a single office.” In a typical month, Craigslist posts more than 10 million items of “user-supplied information,” and user postings are increasing at a rate of approximately 100% per year.

[The granted permission to the National Fair Housing Alliance, as well as Amazon, AOL, Google, Yahoo! and eBay, among others, to submit amicus briefs.]

II. The Pleadings

Craigslist operates a website that allows third-party users to post and read notices for, among other things, housing sale or rental opportunities. The website, which is accessible at “chicago.craigslist.org” (among other web addresses), is titled “craigslist: chicago classifieds for jobs, apartments, personals, for sale, services, community: Non-commercial bulletin board for events, jobs, housing, personal ads and community discussion.” The website contains a link entitled “post to classifieds” that, if clicked, will display a webpage located at “post.craigslist.org/chi” and titled “*chicago craigslist* >> create posting.” That webpage categorizes posts and advertisements and offers the following links: (1) “job,” (2) “gigs,” (3) “housing,” (4) “for sale/wanted,” (5) “resume,” (6) “services offered,” (7) “personal/romance,” (8) “community,” and (9) “event.” The webpage also contains additional links labeled “*log into your account*” and “(*Apply for Account*).”

When a user clicks on the website link “housing,” the website will display a page located at “post.craigslist.org/chi/H” that bears the title “*chicago craigslist* > housing > create posting” and contains a line reading “Are you offering space/housing, or do you need space/housing?” On this webpage, directly under this quoted text, there are two links labeled “I am offering housing” and “I need housing” as well as two other links (at the upper right of the page) labeled “log into your account” and “(Apply for Account).”

[***] When home-seekers are interested in posted sale or rental housing opportunities, they obtain the necessary contact information from content published on Craigslist’s website.

CLC alleges that, through the above-described process, Craigslist publishes housing advertisements on its website that indicate a preference, limitation, or discrimination, or an intention to make a preference, limitation, or discrimination, on the basis of race, color, national origin, sex, religion and familial status. (*See also id.* ¶¶ 142–51 (alleging that CLC continuously monitors Craigslist’s website and that it has diverted substantial time and money away from its fair housing program to efforts directed in response to Craigslist’s publication of discriminatory housing advertisements).) Here is a sampling of the allegedly objectionable statements within rental postings on Craigslist’s website:

- “African Americans and Arabians tend to clash with me so that won’t work out” (Pl.’s Compl. at ¶ 17)
- “Neighborhood is predominantly Caucasian, Polish and Hispanic” (*Id.* at ¶ 18)
- “NO MINORITIES” (*Id.* at ¶ 19)
- “Non–Women of Color NEED NOT APPLY” (*Id.* at ¶ 21)
- “looking for gay latino” (*Id.* at ¶ 24) *686
- “This is not in a trendy neighborhood—very Latino” (*Id.* at ¶ 26)
- “This neighborhood is probably what you’ve heard ... predominantly hispanic, but changing slowly” (*Id.* at ¶ 27)
- “All in a vibrant southwest Hispanic neighborhood offering great classical Mexican culture, restaurants and businesses” (*Id.* at ¶ 28)
- “Requirements: Clean Godly Christian Male.” (*Id.* at ¶ 30)
- “Owner lives on the first floor, so tenant must be respectful of the situation, preferably not 2 guys in their mid twenties, who throw parties all the time” (*Id.* at ¶ 33)
- “LADIES PLEASE RENT FROM ME” (*Id.* at ¶ 34)
- “This is what I am looking for ... and the more a candidate has, the less I will ask in rent: Female Christian” (*Id.* at ¶ 37)
- “Christian single straight female needed.” (*Id.* at ¶ 39)
- “Only Muslims apply” (*Id.* at ¶ 40)
- “near St Gertrudes [sic] church” (*Id.* at ¶ 41)
- “Walk to shopping, restaurants, coffee shops, synagogue.” (*Id.* at ¶ 43)
- “very quiet street opposite church” (*Id.* at ¶ 48)
- “Catholic Church, and beautiful Buddhist Temple within one block” (*Id.* at ¶ 54)
- “Apt. too small for families with small children” (*Id.* at ¶ 60)
- “Perfect for 4 Med students” (*Id.* at ¶ 61)
- “Perfect place for city single” (*Id.* at ¶ 63)
- “Absolutely ideal for a young professional and socialite!” (*Id.* at ¶ 67)
- “Perfect for Young Family or 2 Broke ASS Roommates” (*Id.* at ¶ 79)
- “Young cool landlord who wants one nice quiet person to rent her basement” (*Id.* at ¶ 81)
- “Non-smoking adults preferred” (*Id.* at ¶ 82)

CLC alleges that these and similar statements discourage or prohibit home-seekers from pursuing housing and thus decrease the number of units available to them. (*Id.* at ¶¶ 16, 20, 22, 29, 35, 59.)

I. The Statutes at Issue

A. The Fair Housing Act

To redress this alleged injury, CLC here seeks a declaratory judgment that Craigslist violated 42 U.S.C. § 3604(c) (“Section 3604”) of the FHA, ...which “prohibits racial discrimination of all kinds in housing.” *Tyus v. Urban Search Mgmt.*, 102 F.3d 256, 260 (7th Cir.1996). Section 3604(c), in particular, makes it unlawful:

To make, print, or publish, or cause to be made, printed, or published any notice, *687 statement, or advertisement, with respect to the sale or rental of a dwelling that indicates any preference, limitation, or discrimination based on race, color, religion, sex, handicap, familial status, or national origin, or an intention to make any such preference, limitation, or discrimination.

42 U.S.C. § 3604(c). As the NFHA points out in its *amicus* submission, courts have held that Section 3604(c) applies to a variety of media, including newspapers, brochures, multiple listing services, telecommunication devices for the deaf, a housing complex’s “pool and building rules,” as well as “any other publishing medium.” [cc] Along the same lines, the United States Department of Housing and Urban Development (“HUD”) has issued a regulation ... construing Section 3604(c) as applying to “[w]ritten notices and statements includ[ing] any applications, flyers, brochures, deeds, signs, banners, posters, billboards or any documents used with respect to the sale or rental of a dwelling.” 24 C.F.R. § 100.75.

B. The Communications Decency Act

Notwithstanding the FHA’s broad scope, Craigslist argues that Plaintiff’s Complaint fails on the pleadings because of the immunity afforded under Section 230(c)(1) of the CDA. Section 230(c) consists of two operative provisions, each under the subheading “Protection for Blocking and Screening of Offensive Materials:”²⁴⁷

*688 (c) Protection for “good samaritan” blocking and screening of offensive material

²⁴⁷ In the two subsections immediately preceding Section 230(c), Congress identified certain findings and policies: (a) Findings. The Congress finds the following: (1) The rapidly developing array of Internet and other interactive computer services available to individual Americans represent an extraordinary advance in the availability of educational and informational resources to our citizens. (2) These services offer users a great degree of control over the information that they receive, as well as the potential for even greater control in the future as technology develops. (3) The Internet and other interactive computer services offer a forum for a true diversity of political discourse, unique opportunities for cultural development, and myriad avenues for intellectual activity. (4) The Internet and other interactive computer services have flourished, to the benefit of all Americans, with a minimum of government regulation. (5) Increasingly Americans are relying on interactive media for a variety of political, educational, cultural, and entertainment services. (b) Policy. It is the policy of the United States—(1) to promote the continued development of the Internet and other interactive computer services and other interactive media; (2) to preserve the vibrant and competitive free market that presently exists for the Internet and other interactive computer services, unfettered by Federal or State regulation; (3) to encourage the development of technologies which maximize user control over what information is received by individuals, families, and schools who use the Internet and other interactive computer services; (4) to remove disincentives for the development and utilization of blocking and filtering technologies that empower parents to restrict their children’s access to objectionable or inappropriate online material; and (5) to ensure vigorous enforcement of Federal criminal laws to deter and punish trafficking in obscenity, stalking, and harassment by means of computer. 47 U.S.C. Sec. 230 (a), (b).

(1) Treatment of publisher or speaker

No provider or user of an interactive computer service shall be treated as the publisher or speaker of any information provided by another information content provider.

(2) Civil liability. No provider or user of an interactive computer service shall be held liable on account of—

(A) any action voluntarily taken in good faith to restrict access to or availability of material that the provider or user considers to be obscene, lewd, lascivious, filthy, excessively violent, harassing, or otherwise objectionable, whether or not such material is constitutionally protected; or

(B) any action taken to enable or make available to information content providers or others the technical means to restrict access to material described in paragraph (1). 47 U.S.C. § 230(c). ...

[Note: “Interactive computer service” means: “any information service, system, or access software provider that provides or enables computer access by multiple users to a computer server ...”. “Information content provider” means “any person or entity that is responsible, in whole or in part, for the creation or development of information provided through the Internet or any other interactive computer service.” 47 U.S.C. §§ 230(f)(2), (f)(3).]

These provisions preempt contrary state law, but do not “prevent any State from enforcing any State law that is consistent with this section.” 47 U.S.C. § 230(e)(3). In addition, Section 230 exempts certain areas of law from its scope, but the FHA is not among them. *See* 47 U.S.C. §§ 230(e)(1), (2), (4) (excluding intellectual property laws, criminal laws, and the Electronic Privacy Act).

Near-unanimous case law holds that Section 230(c) affords immunity to ICSs against suits that seek to hold an ICS liable for third-party content. ... Congress recognized the threat that tort-based lawsuits pose to freedom of speech in the new and burgeoning Internet medium. The imposition of tort liability on service providers for the communications of others represented, for Congress, simply another form of intrusive government regulation of speech. Section 230 was enacted, in part, to maintain the robust nature of Internet communication and, accordingly, to keep government interference in the medium to a minimum. * * *

Congress made a policy choice, however, not to deter harmful online speech through the separate route of imposing tort liability on companies that serve as intermediaries for other parties’ potentially injurious messages.

Congress’ purpose in providing the § 230 immunity was thus evident. Interactive computer services have millions of users. The amount of information communicated via interactive computer services is therefore staggering. The specter of tort liability in an area of such prolific speech would have an obvious chilling effect. It would be impossible for service providers to screen each of their millions of postings for possible problems. Faced with potential liability for each message republished by their services, interactive computer service providers might choose to severely restrict the number and type of messages posted. Congress considered the weight of the speech interests implicated and chose to immunize service providers to avoid any such restrictive effect. [Citations omitted] Virtually all subsequent courts that have construed Section 230(c)(1) have followed [early precedents upholding

immunity] ... and several have concluded that *690 Section 230(c)(1) offers ICSs a “broad,” “robust” immunity [citations omitted].

*692 III. The Scope of Section 230(c)(1)

The parties dispute the operative effect of Section 230(c)(1). CLC argues that..., Section 230(c)(1) must be read only as a definitional clause that provides no immunity on its own, but rather determines the subset of ICSs that fall within the grant of immunity afforded under Section 230(c)(2). (R. 16–1, Pl.’s Resp. at 8 (“[u]nder [a] straight-forward reading of Section 230(c)(1), an interactive computer service provider would, if it created the offensive material, be subject to treatment as a speaker or publisher and thus understandably would ‘lose the benefit’ of civil liability protection under (c)(2)—because as the author of the content it could not credibly maintain that good faith efforts were made to prevent the offensive disclosure. But where an interactive computer service does not create the offensive information, it is merely the provider or user, and will be entitled to civil liability protection only for its efforts to block and screen.”).)

Craigslist, in contrast, argues that Section 230(c)(1) grants immunity as to all causes of action against an ICS (so long as the ICS is not the originator of the content at issue). (R. 15–1, Def.’s Motion at 2 (“As a matter of clear federal law, an entity such as [C]raigslist may not be held liable for unlawful content that, as here, originates not from [C]raigslist but from users of the [C]raigslist website. [C]raigslist falls squarely within the protection afforded by [Section 230], which broadly immunizes interactive computer service providers from liability for third-party content.”).) The Court rejects both positions. ...

[T]he Court concludes that Section 230(c)(1) does not bar “any cause of action,” as ... Craigslist contends, but instead is more limited—it bars those causes of action that would require treating an ICS as a publisher of third-party content.

... Section 230(c)(1) provides that *696 “[n]o provider ... of an interactive computer service shall be treated as a publisher”—a term the CDA does not define— “for information provided by another information content provider.” While this language does not grant immunity *per se*, *cf.* 47 U.S.C. § 230(c)(2), it does prohibit treatment as a publisher, which, quite plainly, would bar any cause of action that requires, to establish liability, a finding that an ICS published third-party content. As the Seventh Circuit already has suggested, “defamation law would be a good example of such liability,” ... so too, as it turns out, are causes of action under Section 3604(c). 42 U.S.C. § 3604(c) (rendering it illegal “[t]o make, print, *or publish*, or cause to be made, printed, *or published* any [discriminatory] notice, statement, or advertisement ...” (emphasis added)).

This plain meaning of the statutory text is not at odds with the intentions of Section 230(c)(1)’s drafters. Indeed, Congress did not intend to grant a vast, limitless immunity, but rather enacted Section 230(c) specifically to overrule the court decision in *Stratton Oakmont, Inc. v. Prodigy Services Co.*, 1995 WL 323710 (N.Y.Sup.Ct. May 24, 1995). *See, e.g.*, H.R. Conf. Rep. No. 104–458, at 194 (1996) (“One of the specific purposes of this section is to overrule *Stratton Oakmont v. Prodigy* and any other similar decisions which have treated such providers and users as publishers or speakers of content that is not their own because they have restricted access to objectionable material. The conferees believe that [*Stratton Oakmont*] create[s] serious obstacles to the important federal policy of empowering parents to determine the content of communications their children receive through interactive computer services.”). In that case, the court held that an internet access provider who used filtering technology

could be held liable for libelous third-party statements posted on its bulletin board service. *Stratton Oakmont*, 1995 WL 323710 at *2–4 (determining that, under defamation law, Prodigy, an internet access provider, was a publisher rather than a distributor because “[b]y actively utilizing technology and manpower to delete notes from its computer bulletin boards on the basis of offensiveness and ‘bad taste’... PRODIGY is clearly making decisions as to content ... and such decisions constitute editorial control”).

Thus, when Congress enacted Section 230(c), it did so to address the problem of holding liable for defamation ICSs that reviewed third-party content (as in *Stratton Oakmont*,) while leaving free from liability ICSs that did not review content. ... Even though Congress specifically aimed to overrule *Stratton Oakmont*, a defamation case, it did so by using language—a prohibition against “treat[ing] [an ICS] as a publisher”—that plainly bars any claim *697 that requires “publishing” as an element. ... In any event, regardless of whether Congress chose Section 230(c)(1)’s language with the FHA in mind, what is important here is that the plain meaning of the statute *is not at odds* with Congress’ intent. ... The Court’s reading is at least as harmonious with congressional intent as either of the parties’ proposed alternatives—Congress enacted Section 230(c)(1) to overrule *Stratton Oakmont*, not to create limitless immunity (as Craigslist suggests) or no immunity at all (as CLC suggests).

Other rules of statutory construction further support the Court’s reading. Limiting the immunity afforded under Section 230 to those claims that require “publishing” as an essential element—as opposed to *any* cause of action—gives effect to the different language in Sections 230(c)(1) and (c)(2).²⁴⁸ Moreover, the Court’s reading does not clash with the statutory captions. *See United States v. Tedder*, 403 F.3d 836, 844 (7th Cir.2005) (statutory “[t]itles, headings, and captions may help disambiguate adopted texts, but they are not themselves rules of law”). Indeed, as the Seventh Circuit has observed, it seems rather unlikely that, in enacting the CDA and in trying to protect “Good Samaritans” ... filtering offensive conduct, Congress would have intended a broad grant of immunity for ICSs that do *not* screen any third-party content whatsoever. ... And because it is something less

²⁴⁸ As further dicta in *GTE* suggests, however, the Court’s construction likely is not the doomsday scenario that Craigslist and the Service Providers make it out to be. Indeed, future plaintiffs likely will have a tough row to hoe even without an absolute grant of immunity to ICSs:

Plaintiffs do not cite any case in any jurisdiction holding that a service provider must take reasonable care to prevent injury to third parties. Consider the Postal Service or Federal Express, which sell transportation services that could be used to carry harmful articles. As far as we can discover, no court has held such a carrier liable for failure to detect and remove harmful items from shipments.... Similarly, telephone companies are free to sell phone lines to entities ... without endeavoring to find out what use the customers make of the service.... Yet an ISP, like a phone company, sells a communications service; it enabled Franco, [the defendant], to post a web site and conduct whatever business Franco chose. That GTE supplied some inputs (server space, bandwidth, and technical assistance) into Franco’s business does not distinguish it from the lessor of Franco’s office space or the shipper of the tapes to its customers. Landlord, phone company, delivery service, and web host all could learn, at some cost, what Franco was doing with the services and who was potentially injured as a result; but state law does not require these providers to learn, or to act as Good Samaritans if they do. The common law rarely requires people to protect strangers, or for that matter acquaintances or employees. *GTE*, 347 F.3d at 661.

than an absolute grant of immunity, state legislatures may be able to enact, consistent with Section 230, initiatives²⁴⁹ that induce or require online service providers to protect the interests of third parties ... For all these reasons, the Court here holds that, at a minimum, Section 230(c)(1) bars claims, like the CLC's claim, that requires publishing as a critical element.²⁵⁰

Applying Section 230(c)(1) here, CLC's claim fails on the pleadings. First, Craigslist is a "provider ... of an interactive computer service" because, as alleged in the Complaint, Craigslist operates a website that multiple users have accessed to create allegedly discriminatory housing notices. *See also* 47 U.S.C. § 230(f)(2) (defining "interactive computer service" as "any information service, system, or access software provider that provides or enables computer access by multiple users to a computer server"). These notices, in turn, are "information" that originates, not from Craigslist, but from "another information content provider," namely the users of Craigslist's website. 47 U.S.C. § 230(f)(3) (defining "information content provider" as "any person or entity that is responsible, in whole or in part, for the creation or development of information provided through the Internet or any other interactive computer service"). As a "provider ... of an interactive computer service" that serves as a conduit for "information provided by another information content provider," Craigslist "shall not be treated as a publisher." 47 U.S.C. § 230(c)(1). Because to hold Craigslist liable under Section 3604(c) would be to treat Craigslist as if it were the publisher of third-party content, the plain language of Section 230(c)(1) forecloses CLC's cause of action.²⁵¹ *See also* 47 U.S.C. § 230(e) (excluding *699 certain laws from Section 230's scope, but not excluding the FHA) ...

CONCLUSION

For these reasons, the Court grants Craigslist's Rule 12(c) motion for judgment on the pleadings.

²⁴⁹ The Court is not definitively reaching—because it need not—the issue of whether states may in fact enact such initiatives.

²⁵⁰ Even though Section 230(c)(1) provides something less than absolute immunity, it nonetheless could also be a definitional clause, as CLC contends and as Judge Easterbrook alternatively suggests. The two readings are not mutually exclusive. Although Section 230(c)(1) could operate, consistent with the Court's holding, to define the scope of immunity under Section 230(c)(2), the Court need not reach that issue because, given the Court's construction of the statute, it is not essential to the current motion. To be clear, the Court holds here that Section 230(c)(1) is not only a definitional clause or only a threshold to receiving immunity under Section 230(c)(2). Whether it is such a definitional clause is an issue for another day.

²⁵¹ CLC and the NFHA contend that, even if the Court construes Section 230(c)(1) as barring claims that have "publishing" as an essential element, CLC's claim can proceed because Section 3604(c) also prohibits the "mak[ing]" and "print[ing]" of discriminatory housing notices. [c] The Court disagrees. The Complaint cannot state a claim for relief under Section 3604(c) because, even when viewed in the most favorable light, Craigslist has not made or printed the notices at issue. Craigslist did not "make" the notices because they originated from users of Craigslist's website, and it did not "print" them within any reasonable interpretation of that word, as defined when Congress enacted the FHA. *See, e.g.,* WEBSTER'S THIRD NEW INTL DICTIONARY (1981) (defining "print" as "1a: to make an impression in or upon ... 1b: to make a copy of by impressing paper against an inked printing surface or by an analogous method; 2b to perform or cause to be performed all or some of the operations necessary to the production of (as a publication, a piece of printed matter, a picture ...)"); *see also Sanders v. Jackson*, 209 F.3d 998, 1000 (7th Cir.2000) ("The cardinal rule is that words used in statutes must be given their ordinary and plain meaning. We frequently look to dictionaries to determine the plain meaning of words, and in particular we look at how a phrase was defined at the time the statute was drafted and enacted."). Perhaps recognizing that Craigslist's alleged conduct would not fit within the plain meaning of these terms, CLC asserts throughout its Complaint only that Craigslist "published" the notices at issue.

Note 1. What is the compelling interest that Section 230 is addressing? How is it connected to the concerns of *Sullivan* and its progeny? What justifications do you see for resolving concerns through creating federal legislation granting immunity, versus creating standards that require case-by-case adjudication? And does the provision of immunity matter if it results in litigation anyway?

Note 2. Do you agree with the court’s ruling, normatively? Should Section 230 confer as much power (or latitude) as it does? What are the alternatives?

Note 3. The opinion in *CLC v. Craigslist* makes arguments rooted in legislative intent, legal policy, and statutory construction. The court cites to Webster’s Dictionary, for instance, twice—once in a section on the meaning of the word “publisher,” which has been edited out of your version, and a second time in its final footnote on the definition of the word “print.” In so doing, the court displays textualist tendencies and inclines towards formalism. In other instances, such as when it considers the effect on various stakeholders (Good Samaritan content filterers, among others), it inclines towards functionalism. Does this case remind you of Justice Traynor’s approach to products liability law, or of other instances of judicial reasoning?

Check Your Understanding (7-2)

Question 1. Complete the sentence: Actual malice...

An interactive H5P element has been excluded from this version of the text. You can view it online here: <https://saidtorts2d.lawbooks.cali.org/?p=107#h5p-128>

Question 2. A grocery store owner, G, is worried about protests and social unrest, which have cost him extensively disrupted business in the recent past. He takes a strong stand by refusing to allow employees to wear buttons or pins (“flair”) in support of any political movements. He fires an employee for wearing a “BLM” pin and suspends another for wearing a “Vote like your life depends on it” pin. G’s reasoning is that the first was expressly political, in violation of his new policy, whereas the second was somewhat political, and while it also seemed possibly inconsistent with his policy, it was harder to punish someone for calling for voting, if they were not calling for voting for a particular party or person, or expressing support for any particular movement.

G gets attacked on Twitter for supposedly censoring his employees, creating a hostile environment, and discouraging voting, especially among his employees of color. Several of the Tweets are partially or wholly untrue and all are negative. One Tweet accuses him of being a modern-day colonialist extracting labor from people he can exploit without recognizing their rights to participate in public discourse. G is especially upset by this Tweet. As the child of

immigrants himself, he is familiar with the sense of being exploited and undervalued. He feels wrongly accused because his decisions around whether pins should be worn at work do not reflect his views about justice, but he also can't afford to be caught in the middle of a public debate. He is trying to make rent on an expensive location in Seattle, and he needs to conduct sufficient business to do so. As he sees that his business starts suffering sharply following the Tweets, he tries to Tweet that the truth is more complicated. He offers his own version of what happened, or he tries to (in 140 characters or fewer). His account is shouted down or ignored on Twitter. Feeling he has no other option to protect his livelihood, he decides to sue the author of the Tweet for defamation.

Which of the following, if true, would be most likely to result in G's having to prove actual malice by the author of the Tweet?

An interactive H5P element has been excluded from this version of the text. You can view it online here: <https://saidtorts2d.lawbooks.cali.org/?p=107#h5p-129>

Question 3. In addition to the facts from the prior question, G now receives this note on the desk in his office at work:

“Why do big businesses try to keep people down, cheat the tax code and exploit loopholes? You cheat the system! You use your powers for ill instead of good, trying to silence and oppress essential workers!

No BLM? = no Bottom Line Money for you!”

He finds the messages contained in the note to be objectionable. Without more information, which of the answer choices below is likely to pose the greatest obstacle to G to if he sues on the basis of the allegedly defamatory statement below?

An interactive H5P element has been excluded from this version of the text. You can view it online here: <https://saidtorts2d.lawbooks.cali.org/?p=107#h5p-130>

In addition to the federal limits the CDA places on defamation lawsuits, a number of states have attempted further to limit liability for defamation. Many states have passed legislation that creates immunity from defamation suits in cases in which the claims appear to be motivated by a desire to limit or repress speech about an important public matter. Known as “Anti-SLAPP” statutes, they seek to prevent litigation that appears to be nothing more than “Strategic Litigation Against Public Participation.” These statutes are important to know of, even though they are not applicable in all states.

In a number of states, the Anti-SLAPP statute has faced constitutional challenges in court and some have been struck down in whole or in part. The next case features a recent dispute in which Florida's Anti-SLAPP statute was at issue.

Bongino v. Daily Beast Co., LLC, U.S. District Court, S.D. Florida (2020) (477 F. Supp.3d 1310)

Plaintiff Dan Bongino is a public figure. A former Secret Service member, Mr. Bongino describes himself as “an outspoken supporter of President Donald Trump. He hosts a podcast, appears on Fox News, writes books, and has more than 1,500,000 followers on social media. Until 2018, he hosted a show on NRATV, the National Rifle Association’s online video channel.

Upon learning that Bongino’s show would no longer air, Defendant’s reporter texted him and asked, “Heard you didn’t renew with NRA TV?” Bongino did not respond. Four days later, the reporter texted again, “Just circling back on this. Probably publishing something today.” Still, no response. Defendant then published an article titled, “Dan Bongino out at NRATV—BONGI-NO-MORE.” (Lachlan Markay, *Dan Bongino Out at NRATV*, The Daily Beast, <https://www.thedailybeast.com/sources-dan-bongino-out-at-nratv> (last updated Dec. 11, 2018 2:11 PM)). The article’s subheading reads, “Trump loves the guy. But the gun rights group is downsizing its media operation and his show appears to be a casualty of those plans.” The first sentence continues, “The National Rifle Association’s media arm has dropped pro-Trump firebrand Dan Bongino....”. The article also notes that neither Bongino nor the NRA responded *1315 to Defendant’s requests for comments at first.

After publication, however, Bongino and NRATV responded to the article publicly. The next day, Defendant revised the article to include their reactions. The article now reads, “[Bongino] suggested that the decision not to renew the show was his, not the network’s” and “NRATV released a statement saying the network ‘made every attempt to retain [Bongino] in 2019’ but did not elaborate on the negotiations.”

That article is the basis for this suit. [***] Bongino claims the article conveys that NRATV fired him for cause; in truth he decided not to renew his contract, he says. On that basis, he argues the article “imputes” to him an “unfitness to perform the duties” of his job, and therefore constitutes libel.

Defendant now moves to dismiss the Complaint under Federal Rule of Civil Procedure 12(b)(6). [***] Defendant seeks to recover attorneys’ fees and costs under Florida’s anti-SLAPP statute, which the Florida legislature enacted to prohibit lawsuits that “are inconsistent with the right of persons to exercise ... free speech in connection with public issues.” See Fla. Stat. § 768.295(1). The Court addresses these arguments in turn.²⁵² [***]

²⁵² The Court first notes that Plaintiff’s Complaint serves as the most common form of a stereotypical shotgun pleading and runs afoul of the Federal Rules of Civil Procedure and Eleventh Circuit precedent in that it “contains several counts, each one incorporating by reference the allegations of its predecessors [i.e., predecessor counts], leading to a situation where most of the counts (i.e., all but the first) contain irrelevant factual allegations and legal conclusions.” *Strategic Income Fund, L.L.C. v. Spear, Leeds & Kellogg Corp.*, 305 F.3d 1293, 1295 (11th Cir. 2002); see also *Magluta v. Samples*, 256 F.3d 1282, 1284 (11th Cir. 2001) (identifying a complaint as a shotgun pleading where “[e]ach count incorporates by reference the allegations made in a section entitled ‘General Factual

Plaintiff emphasizes that the “gist” of Defendant’s article implies to a reasonable reader that Plaintiff was fired for cause. Specifically, Plaintiff objects to the article’s statement that, “[t]he National Rifle Association’s media arm has dropped ... Dan Bongino from its lineup of conservative commentators,” because he, not NRATV, decided to end the employment relationship. Plaintiff claims this misrepresentation imputes to him an “unfitness to perform the duties” of his job as a political commentator and radio host. For those reasons, he charges Defendant with defamation and defamation by implication. The Court addresses each claim in turn.

a) Defamation

[***] Whether a statement is susceptible to defamatory interpretation is a question of law left to the Court. [c] This inquiry turns on the “gist” of the alleged defamatory statement and the context in which that statement was made. [***] But when a communication “could not possibly have a defamatory or harmful effect, the court is justified in dismissing the complaint for failure to state a cause of action.” *Rubin v. U.S. News & World Report, Inc.*, 271 F.3d 1305, 1306 (11th Cir. 2001) (citation omitted).

As an initial matter, at least one Florida court has held “the statement that a person was ‘fired’ from his employment, without more, is not defamatory.” *Burnham v. Palm Beach Newspapers, Inc.*, 21 Med. L. Rptr. 1914 (Fla. 15th Cir. Ct. June 25, 1993). The state court held that an employer’s ability to terminate an employee is “inherent in the employment relationship” and the “exercise of that right does not necessarily impute wrongdoing to the employee.” *Id.* [c]

Indeed, Defendant cites to a litany of authority—albeit from non-binding jurisdictions—agreeing with the premise that “[t]he mere statement that someone has been terminated from employment is not in and of itself defamatory,” unless “the publication contains an insinuation that the discharge was for some misconduct.” [c]; *see also, e.g., Klein v. Victor*, 903 F. Supp. 1327, 1335–36 (E.D. Mo. 1995) (“Even assuming that the statement is false, and that plaintiff was not actually terminated, that statement does not necessarily impute a want of knowledge, skill, capacity or fitness to perform, nor does it impute fraud, want of integrity or misconduct ...”); *Jack’s Cookie Co. v. Brooks*, 227 F.2d 935, 937 (4th Cir. 1955) (letter stating that plaintiff was “no longer the sales representative of Jack’s Cookie Company” and that this was “best for the company, its distributors, representatives and customers” was not defamatory as a matter of law because it “could not fairly be interpreted as charging [plaintiff] either with incompetence or dishonesty”).

Seeming to acknowledge that, without more, the mere statement that an individual was terminated does not constitute defamation, Plaintiff makes much ado about the article’s apparent insinuation that Plaintiff was not only fired but fired “for cause.” (*See* Pl.’s Resp. at 8–9 (citing caselaw specific to statements that individual was fired for cause or other misconduct)). A plain reading of the article, however, renders Plaintiff’s authority inapposite.

Here, even a cursory review reveals that nowhere in the article does it state that Plaintiff was fired—much less that he was fired for cause. The article merely states that NRATV “dropped” Plaintiff from its lineup of conservative commentators. And as Plaintiff concedes, this is in fact true. *See Masson*

Allegations’—which comprise[d] 146 numbered paragraphs—*while also incorporating the allegations of any count or counts that precede[d] it.*”) (emphasis added). Nonetheless, because the Court is able to discern the basis of the Complaint, the Court will proceed on the merits.

v. New Yorker Mag., Inc., 501 U.S. 496, 516 (1991) (explaining that even a flawed assertion of fact is not actionable as long as it is “substantial[ly] tru[e],” because the common law of libel “overlooks minor inaccuracies”). Indeed, the article’s subheading explains that NRATV was “downsizing” and Plaintiff’s show was “a casualty of those plans.” The article even reflects that NRATV made “every effort to retain [Bongino].” *Id.*²⁵³ Such reporting is a far cry *1319 from stating that Plaintiff was fired for anything other than corporate downsizing.

[***] In short, even if the Court were to agree with Plaintiff that the “gist” of the article states that he was fired, the Court agrees with the reasoning set forth in the foregoing authority that the mere statement that an individual was terminated, without an insinuation of misconduct, does not constitute defamation. Because no reasonable interpretation of the article could be construed to suggest that Plaintiff was “dropped” for any reason other than fiscal decision-making, Plaintiff fails to establish that the article amounts to defamation.

b) Defamation by Implication

Plaintiff’s alternative claim for defamation by implication fails for the same reasons. Defamation by implication occurs when “the defendant juxtaposes a series of facts so as to imply a defamatory connection between them,” or when the defendant “creates a defamatory implication by omitting facts.” [c] In this sense, defamation by implication imposes “liability upon the defendant who has the details right but the ‘gist’ wrong.” [c] That said, “[a]ll of the protections of defamation law that are afforded to the media and private defendants” also apply “to the tort of defamation by implication.” [c] This includes true statements and statements of pure opinions, which are protected by the First Amendment. [c] (“Under Florida law, a defendant publishes ‘pure opinion’ when the defendant makes a comment or opinion based on facts which are set forth in the publication....”).

In support of his defamation by implication allegation, Plaintiff claims the article implies that NRATV dropped him because of his “quick temper,” “brash style,” and because he was an “outspoken defender of President Trump.” But the article does not juxtapose those snippets to imply they are *1320 the reason that NRATV dropped Bongino. Nevertheless, such statements are, at the very least, protected statements of pure opinion.

For starters, the article states, “Bongino is known as an outspoken defender of President Trump, and recently released a book alleging ‘an attempt to sabotage’ the president....” The Complaint also describes Plaintiff as “an outspoken supporter of President Donald Trump. In 2018, Plaintiff published ... *Spygate: The Attempted Sabotage of Donald J. Trump*.” Consequentially, the statement is true and thus privileged by the First Amendment. [c] Even still, the article does not juxtapose this soundbite with Plaintiff’s departure from NRATV. In fact, the article suggests NRATV embraced the “style of commentary that dovetails with contemporary conservative rhetoric,” thereby suggesting Plaintiff’s support for Trump was valuable to the station.

²⁵³ The Court notes that the article before it appears to have been edited after initial publication to reflect the comments made by both Plaintiff and officials from NRATV. As an initial matter, this highlights the importance of § 770.01’s pre-suit notice requirement in that it allows such redactions or republications to occur prior to suit. Nonetheless, Plaintiff does not dispute the attached article’s applicability to the instant motion to dismiss. *See Jones v. Bank of Am., N.A.*, 564 F. App’x 432, 434 (11th Cir. 2014) (“[A] party’s failure to respond to any portion or claim in a motion indicates such portion, claim or defense is unopposed.”).

Next is the article’s reference to Plaintiff’s “quick temper,” and “brash style.” Those comments both opine on a “2016 interview with Politico reporter Marc Caputo, which ended with Bongino screaming obscenities at the journalist before hanging up.” These comments, however unflattering, are “pure opinion” and thus protected by the First Amendment. [cc] (explaining that statements of opinion cannot support claim for defamation by implication).

In sum, dismissal is proper because “no construction” of the article will support Plaintiff’s defamation charge. [c] And notably, the Eleventh Circuit acknowledges a “powerful interest in ensuring that free speech is not unduly burdened by the necessity of defending against expensive yet groundless litigation.” *Michel*, 816 F.3d at 702. [***]

C. Florida’s Anti-SLAPP statute

Florida’s anti-SLAPP statute prohibits a person from filing a suit that is (a) “without merit” and (b) “primarily” because the person against whom the suit was filed “exercised the constitutional right of free speech in connection with a public issue....” Fla. Stat. § 768.295(3). The Florida legislature enacted the statute to deter such suits, finding they are “inconsistent” with the constitutional right of free speech—the preservation of which is a “fundamental state policy[.]” *Id.* § 768.295(1). Presumably for that reason, the statute awards a defendant fees and costs if a plaintiff files a forbidden suit. *Id.* § 768.295(4).

***1322** Defendant contends this statute entitles it to recover its fees and costs because Plaintiff filed this lawsuit (a) “without merit” and (b) because Defendant “exercised the constitutional right of free speech in connection with a public issue.” Plaintiff responds by arguing that his suit did not violate the statute because Defendant did not “exercise the constitutional right to free speech on any issue” and contending that this statute does not apply in a federal court anyway.

1. Whether Plaintiff’s suit violated Florida’s anti-SLAPP statute

Florida’s anti-SLAPP statute prohibits a person from filing a cause of action that is (a) “without merit” and (b) “primarily” because the person against whom the suit was filed exercised the constitutional right of free speech in connection with a public issue. Fla. Stat. § 768.295(3). As used in that provision, “free speech in connection with a public issue” includes any written statement protected under applicable law and made in connection with a news report. Fla. Stat. § 768.295(2)(a).

The Eleventh Circuit recently affirmed an order awarding fees and costs under this statute in a case akin, in both posture and substance, to this one. *See Parekh v. CBS*, 820 Fed.Appx. 827 (11th Cir. 2020). The media defendant in *Parekh* filed one motion to dismiss the plaintiff’s defamation claim and to recover fees and costs under Florida’s anti-SLAPP statute. *Id.* at 832. The Eleventh Circuit affirmed the complaint’s dismissal because the disputed statement, even if false, “[was] not actionable because it [was] not defamatory.” *Id.* at 834. For that reason, the suit was filed “without merit.” *Id.* at 835–36. The suit also “arose out of the defendants’ protected First Amendment activity—publishing a news report on a matter of public concern.” *Id.* The Eleventh Circuit thus concluded that the statute’s plain language supported the district court’s decision to grant fees and costs. *Id.*

Because Plaintiff’s suit fails to state a claim for defamation, it was without merit under Florida Statute § 768.295(3). And because Plaintiff’s suit “arose out of” Defendant’s news report, the second element—free speech in connection with a public issue—is also satisfied. *See* Fla. Stat. §

768.295(2)(a); *Parekh*, 820 Fed.Appx. at 831–32. The statute therefore entitles Defendant to recoup reasonable attorneys’ fees and costs.

2. Whether Florida’s anti-SLAPP statute applies in Federal Court

The *Parekh* court declined to address whether Florida’s anti-SLAPP statute applies in federal court because the appellant raised the argument for the first time on appeal. *Parekh*, 820 Fed.Appx. at 836. Plaintiff, however, raises the argument here. That brings the Court to the second question regarding Florida’s anti-SLAPP statute: whether its fee-shifting provision applies in a federal court exercising diversity jurisdiction. As far as the Court is aware, the Eleventh Circuit has not addressed this question. So, this is a matter of first impression.

In such a case, a federal court will not apply a state statute that “answers the same question” as a Federal Rule of Civil Procedure. *See Carbone v. Cable News Network*, 910 F.3d 1345, 1349 (11th Cir. 2018) (addressing whether Georgia’s anti-SLAPP statute applies in federal court) (quotation and citation omitted). The Eleventh, Fifth, D.C., and now Second Circuits agree: certain states’ iterations of the anti-SLAPP statute “answer the same question” as Federal Rules of Civil Procedure 8, 12, and 56. *See Carbone*, 910 F.3d at 1357 (11th Cir. 2018) (Georgia); *1323 *La Liberte v. Reid*, 966 F.3d 79, 85–86 (2d Cir. 2020) (California); *Klocke v. Watson*, 936 F.3d 240, 245 (5th Cir. 2019) (Texas); *Abbas v. Foreign Pol’y Grp., LLC.*, 783 F.3d 1328, 1334 (D.C. Cir. 2015) (D.C.).

Those statutes conflict with the Federal Rules of Civil Procedure because they raise the bar for a plaintiff to overcome a pretrial dismissal motion. *See Carbone*, 910 F.3d at 1350, 1356 (addressing Georgia’s anti-SLAPP statute, which requires the “plaintiff to establish ‘a probability’ that he ‘will prevail on the claim’ asserted in the complaint”); *La Liberte*, 966 F.3d at 87 (addressing California’s anti-SLAPP statute, which requires “dismissal unless the plaintiff can ‘establish a probability that he or she will prevail on the claim’ ”); *Klocke*, 936 F.3d at 246 (addressing Texas’s anti-SLAPP statute, which requires “ ‘clear and specific evidence’ that a plaintiff can meet each element of his claim”); *Abbas*, 783 F.3d at 1333 (addressing D.C.’s anti-SLAPP statute, which requires dismissal when the “plaintiff does not have a likelihood of success on the merits”).

Not so for Florida’s anti-SLAPP statute. *See Fla. Stat.* § 768.295(4). Instead, it fuses with Rules 8, 12, and 56 by entitling the prevailing party to fees and costs if, after invoking the devices set forth by those rules, a court finds an action is “without merit” and thus prohibited. [***] At bottom, Florida’s statute is a garden variety fee shifting provision, which the Florida legislature enacted to accomplish a “fundamental state policy”—detering SLAPP suits. Fla. Stat. § 768.295(1). The result is a statute that does not “answer the same question” as the Federal Rules. *Shady Grove Orthopedic Associates, P.A. v. Allstate Ins. Co.*, 559 U.S. 393, 401 (2010).

This conclusion is in line with decades of Eleventh Circuit precedent, which find that state-law statutes and claims for attorneys’ fees and costs “unequivocally” apply in a federal court exercising diversity jurisdiction. [***] In sum, the Court finds that Florida’s anti-SLAPP fee-shifting provision does not conflict with any Federal Rules of Civil Procedure and thus may apply in a federal court exercising diversity jurisdiction. [***]

Note 1. What does the court mean by “defamation by implication”? What is Bongino’s argument about how he was defamed?

Note 2. What does the court mean when it refers to “pure opinions”? Can “pure opinions” be defamatory, according to *Bongino*?

Note 3. Why did the court reject the reasoning in *Bongino*’s claim that the statements in question had defamed him?

Note 4. Why does the court believe that dismissal is normatively important in this case?

Note 5. Articulate for yourself the purpose of anti-SLAPP statutes. Does it seem to you that the anti-SLAPP statute was properly applied in this case? In future cases, what facts would tend to persuade you to place limits on private persons’ reputational interests?

Note 6. In the present era, defamation lawsuits have taken on an increasingly political dimension. In an era of misinformation and disinformation, some media outlets and platforms have permitted or contributed to the circulation of outright lies about issues of momentous public importance such as COVID-19 vaccine safety and the 2020 Presidential election. A number of lawsuits have been filed by the manufacturer of voting machines, Dominion Voting Systems, which was routinely (and falsely) maligned as having interfered with or tainted the election. An early assessment of those cases seems positive for Dominion Voting. (See e.g. <https://www.latimes.com/entertainment-arts/business/story/2022-07-05/fox-news-defamation-election-lawsuit-dan-webb-dominion>) These lawsuits hint at the possibility that courts could play a role in stemming disinformation. What sorts of mis- and disinformation have you observed in circulation? To what extent does existing case law go far enough, in your view, in balancing speech and reputational interests? Should the politicization of defamation law be recognized and reflected in some way in judicial or legislative action?